

Fire & Life Safety Requirements Guide

for Temporary Use of the Facilities at the Kitsap County Fairgrounds



**Department of
Community Development**

Kitsap.gov/DCD
(360) 337-5777

Help@Kitsap1.com

Revised 4/1/2024

PURPOSE

To publicize the requirements and provide a standard method of approval and inspection for temporary uses of the Kitsap County Fairgrounds.

RESPONSIBILITIES

The event planner or designated responsible party is responsible for obtaining required permits and approvals and ensuring that events and temporary uses are set up and operated safely and are consistent with this guide.

The Kitsap County Fire Marshal or their designee is responsible for determining if temporary uses are consistent with the requirements of this guide and applicable rules, codes, and ordinances of the county before approving any permit or temporary use.

Fairgrounds staff are responsible for providing the permitting requirements for temporary uses of fairgrounds property and assuring that contractees obtain required permits before commencing an event. It is the responsibility of the fairground staff to ensure the contractees have a copy of the permit and are familiar with the permit's conditions.

Where no permit is required, fairgrounds staff must ensure that an event occurs consistent with applicable fire and life safety codes.

CONTENTS

RESPONSIBILITIES	1
FIRE CODE PERMIT	3
INSPECTIONS	4
EXITS.....	4
DRAPERIES, BUNTING, TABLE SKIRTS, DECORATIVE MATERIALS AND VEGETATION	5
DECORATIVE RUGS AND FLOOR COVERINGS.....	5
PROPANE STORAGE, USE AND HANDLING	5
COOKING OPERATIONS	6
MOBILE FOOD PREPARATION VEHICLES	6
ELECTRIC, LIQUID, AND GAS-FUELED VEHICLES AND EQUIPMENT	7
ELECTRICAL HAZARDS	7
TENTS, CANOPIES, AND MEMBRANE STRUCTURES: GENERAL REQUIREMENTS.....	9
ASSEMBLY USES.....	9
CROWD MANAGERS.....	10

APPROVAL

The setup and operational components of all temporary uses of fairgrounds facilities require the approval of fairgrounds staff and the Fire Marshal before commencing any event or activity. Approval for an event may be withdrawn or suspended at any time if the use occurs contrary to this guide, permitting requirements, or any other requirement established for the event.

FIRE CODE PERMIT

A separate fire code permit issued by the Fire Marshal is required to:

- Erect, operate, or use any structure as an AMUSEMENT BUILDING (Halloween "Haunted House" or similar event)
- Conduct a FAIR or CARNIVAL.
- Use OPEN FLAMES or CANDLES (Jointly approved by Kitsap County Fairgrounds)
- Operate a PLACE OF ASSEMBLY where the total number of attendees exceeds 350.
- DISPLAY, OPERATE, or DEMONSTRATE liquid or gas-fueled vehicles within any building.
- To operate a Mobile Food Preparation Vehicle
- Use FIREWORKS or PYROTECHNIC SPECIAL EFFECTS.
- Erect TENTS, CANOPIES, or MEMBRANE STRUCTURES
 - Where any single tent or stage canopy exceeds 400 square feet
 - Where any tent or canopy, or group of individual tents or canopies placed less than twelve feet from one another, and other buildings exceed 700 square feet.
 - Where any air-supported membrane structure (children's inflatable blow-up slides, bouncy houses, and/or other membrane structures supported by air) exceeds 400 square feet.

There may be other conditions that apply to any event or permit, as well as exceptions for small or isolated uses, and those considering these activities should contact the Fire Marshal for clarification.

Permit applications must be submitted to the Department of Community Development with the applicable permit and inspection fee no less than Thirty (30) days before the initial setup for an event. Failure to submit applications thirty days before setup may result in additional fees and application refusal.

In addition to the application and permit fees, applicants must provide:

- A description of the specific use – examples include exhibition or trade show, concert, sporting event, swap meet, haunted house, etc., and information about the sponsor group or individual and who will be the on-site contact and responsible party.
- A floor and/or site plan - Several Standard Plans have been approved for different types of events and are available for review at the time of application. Suppose an applicant elects not to use the Standard Plan or elects to change a previously approved plan. In that case, an additional review, including review fees, shall be submitted before approving the event. Provide on-the-site plans for all outside vendor locations. On the floor plans, show vendor locations, aisle width, exits, etc.

A list of vendors or exhibitors is required and shall include what they will do in their space during the event.

INSPECTIONS

All events and temporary uses requiring a fire code permit must be inspected and approved by the Fire Marshal or designee before their commencement. Fairgrounds, other county staff, or emergency response agencies may accompany the Fire Marshal during an inspection. Events that do not require a fire code permit will be inspected and approved by fairground staff. The Fire Marshal or other county staff or service provider may inspect any event or special use during its setup or operation.

Inspections must be scheduled to occur during the end stages of event setup (the timing may vary depending on the needs of the use) and need to occur so that there is sufficient time to correct anything that needs attention before opening. Typically, the inspection only takes an hour or two when a Standard Plan is used. First-time use or prior uses that have changed their setup will likely require the entire two hours. Please plan accordingly. It shall be the responsibility of the event planner or designated responsible party to ensure that the required inspection takes place and that all corrections are complete before opening the doors to the public. It's recommended that the event coordinator and/or other staff be present during the inspection and to ensure that anything needing correction is accomplished within the time frame established by the inspection staff. It is highly recommended that someone from each booth, exhibit, or other activity be present for the inspection to discuss any corrections.

A Fire Marshal inspection can be arranged by CALLING (360) 337-5777 **NOT LESS THAN ONE WEEK BEFORE THE BEGINNING DATE OF THE EVENT**. One week is needed to coordinate county staffing and ensure the event does not incur additional inspection costs. If an inspection is not scheduled at least one week before the event, it may be subject to additional charges, including overtime for staff.

The following list is provided for the coordinator or responsible party to be aware of and share with their participants to ensure timely approval and that no corrections are needed during the event inspection.

EXITS

Required exit doors, aisles, and areas outside exit doors shall always be kept clear and entirely functional for use in case of fire or other emergencies while the building is occupied.

Furnishings, decorations, draperies, or other objects shall not be placed over or in front of exit doors. Mirrors shall not be located adjacent to any exit. Items for display or sale shall not be in the aisles or at any exit.

Exiting is established for the life safety of participants and attendees and for ordinary and emergency conditions. Do not do anything that could obstruct an exit in an emergency; if there is a question, *please ask before the event*.

DRAPERIES, BUNTING, TABLE SKIRTS, DECORATIVE MATERIALS AND VEGETATION

Curtains, draperies, artificial decorative vegetation, bunting or skirting around tables and exhibit booths, and similar materials shall be made of flame-resistant materials or made flame-resistant before the event. Certification of flame resistance shall be provided and shall consist of a tag or label affixed to the item by the manufacturer indicating its flame resistance or a Valid Certificate of Flame Resistance provided by the manufacturer meeting NFPA 701, ASTM E84, CPAI-84, or California State Fire Marshal Seal.

Highly flammable materials shall not be used. Fire-retardant coatings applied to materials must be applied and maintained per the manufacturer's instructions. Proof of the material applied, and its application must be on site for the inspector during the inspection. Fire-retardant coatings shall meet NFPA 701 standards, ASTM E84, or UL 723.

Plastic tablecloths shall be cut to the size of the table with no overhang or folded and taped underneath the table.

The Fire Marshal strongly encourages participants to rent the pipe and drape, skirting, and similar materials available through the fairgrounds which have been approved. The rental will assist in preventing last-minute changes due to the use of the wrong type of material.

Lightweight plastic skirting is **NOT APPROVED**, if found in place during inspection you will be **REQUIRED TO REMOVE IT**. Although this material is readily available at stores that sell party supplies, it is highly flammable. At the party supply store, you will want to ensure you purchase lightweight plastic that has a flame retardant built in by the manufacturer, but it is expensive. Be sure to verify you have purchased the correct material.

In buildings with ceiling-mounted radiant heating appliances, no combustibles shall be located within five (5) feet of all portions of the appliance.

DECORATIVE RUGS AND FLOOR COVERINGS

All decorative rugs and floor coverings must be taped with blue painter's or gaffing tape to prevent tripping or movement of the rug or floor covering.

PROPANE STORAGE, USE AND HANDLING

Portable LP-gas containers are allowed to be used temporarily for demonstrations. Containers shall not exceed 12 pounds of water capacity or 2.6 gallons of LP gas. For containers that supply self-contained torch assemblies or similar appliances, containers shall not exceed 2 ½ pounds of water capacity or 1 gallon of LP gas. A portable fire extinguisher shall be located between 5 and 30 feet from the location of the use of the LP gas. LP gas containers shall not be positioned on their side or upside down. Containers shall not be located within 10 feet of exits or stairways or in areas typically used or intended to be used for exiting occupants.

If you or one of your vendors or participants anticipates using LPG or any compressed gas in any capacity, be sure to include that information in the vendor list or the description of your event. *Prior knowledge is much better than a surprised inspector!*

Within the Vanzee building, gas connections shall be made by the propane company.

A fire extinguisher must be provided at the booth where the LPG or other compressed gas will be used, and the extinguisher must be new or have a tag indicating service within the last year. Every vendor required to have a minimum of a 2A:10B:C fire extinguisher will be required to demonstrate its proper use during inspection. Remember PASS!! (PASS=Call 911, Point, Aim, Squeeze, and Sweep)

LP gas containers shall be located outside a tent or canopy and not less than 10 feet from the tent or canopy. Multiple containers shall be secured from tipping by placing them in a crate or nesting up to three tanks together.

COOKING OPERATIONS

All cooking operations within buildings emitting grease-laden vapor shall occur under an approved Type 1 hood system. A Class K fire extinguisher is required.

All cooking operations shall have at least one portable fire extinguisher with a minimum 2A:10B:C rating.

All deep fryers shall provide a **Class K-rated** portable fire extinguisher, in addition to the required 2A:10B:C fire extinguisher.

The fire extinguisher must be serviced or new within the last year. Ensure the tag is on it and shows the date purchased or when it was last serviced. Every vendor required to have an extinguisher must demonstrate its proper use during inspection – remember, PASS!! (PASS=Call 911, Point, Aim, Squeeze, and Sweep)

The use of solid or gel-type fuel (Sterno Chafing Fuel) shall be limited based on the recommended manufacturer's design for the warming fixture. If the manufacturer's paperwork is unavailable, then the Fire Marshal or his/her designee shall determine the amount of (Sterno Chafing Fuel) fuel that can be used and stored. Equipment will not be approved to be placed on plastic tablecloths.

MOBILE FOOD PREPARATION VEHICLES

When events are hosting food trucks or trailers where cooking is conducted within the truck or trailer, a separate fire code operational permit must be issued by the Department of Community Development or an approved fire agency within Kitsap County. Each mobile food vehicle must have its own permit before the event. The operational permit is valid for one year.

Food trucks or trailers are not authorized to be inside buildings.

Food trucks or trailers cannot, at any time, be parked in the fire lane.

If a food truck or trailer is in an unauthorized location, they must relocate. If the food truck or trailer has no valid operational permit, they must leave the event.

ELECTRIC, LIQUID, AND GAS-FUELED VEHICLES AND EQUIPMENT

Display of liquid and gas-fueled vehicles and equipment inside a building shall meet the following requirements:

- a) The battery shall be removed or disconnected from the battery terminal and cable end, which will be covered with insulated tape.
- b) Vehicles or equipment shall not be fueled or defueled within any building.
- c) Fuel tanks shall not be more than 1/4 full or contain more than 5 gallons of fuel, whichever is less.
- d) Fuel tanks shall be locked or sealed to prevent tampering or escape of vapors.
- e) The location of vehicles or equipment shall not block exits.
- f) CNG, LNG, LPG (propane), and hydrogen fuel tanks shall have their emergency shut-off valves in the closed position.
- g) Electric vehicles shall be rendered inoperable by removing the fuse. Do not disconnect the battery.
- h) Moving or relocating a vehicle before or during a show may be necessary. For this reason, it is highly recommended that a set of keys be available on-site for all vehicles. Vehicle keys or fobs cannot be stored in the vehicle.

We understand that individuals invest a lot of time, effort and money in their show or display vehicles. Please ensure that the above has been completed before the inspection and either have someone on hand to show the inspector that things have been taken care of or leave the vehicle open to be easily seen. Keys may be left at the Parks Office if no one is available during inspection.

ELECTRICAL HAZARDS

Electrical wiring, devices, appliances, and other equipment that are modified or damaged can constitute an electrical shock or fire hazard and shall not be used. Approved electrical services are provided by the county and are required to be used for electrical service. Please plan accordingly and let fairgrounds staff know your needs before an event.

EXTENSION CORDS: A minimum of 14-gauge extension cords or an approved multiplug adapter shall be used to extend electrical service.

- a. Extension cords shall only be used with portable appliances (a device that moves location when normally used) while such appliances are in immediate use.
- b. Extension cords shall be plugged directly into a permanent electrical outlet and serve only one portable appliance except for approved multiplug extension cords.
- c. The amperage of the extension cords shall not be less than the rated capacity of the portable appliance supplied by the cord.
- d. The extension cords shall be grounded when servicing grounded portable appliances.
- e. Extension and flexible cords shall not be subject to environmental or physical damage. Cords shall be protected against physical damage from walking or other hazards.

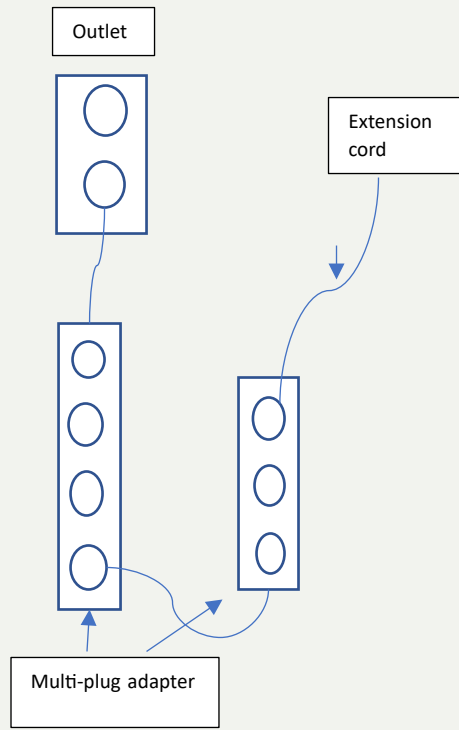

NOT APPROVED

APPROVED

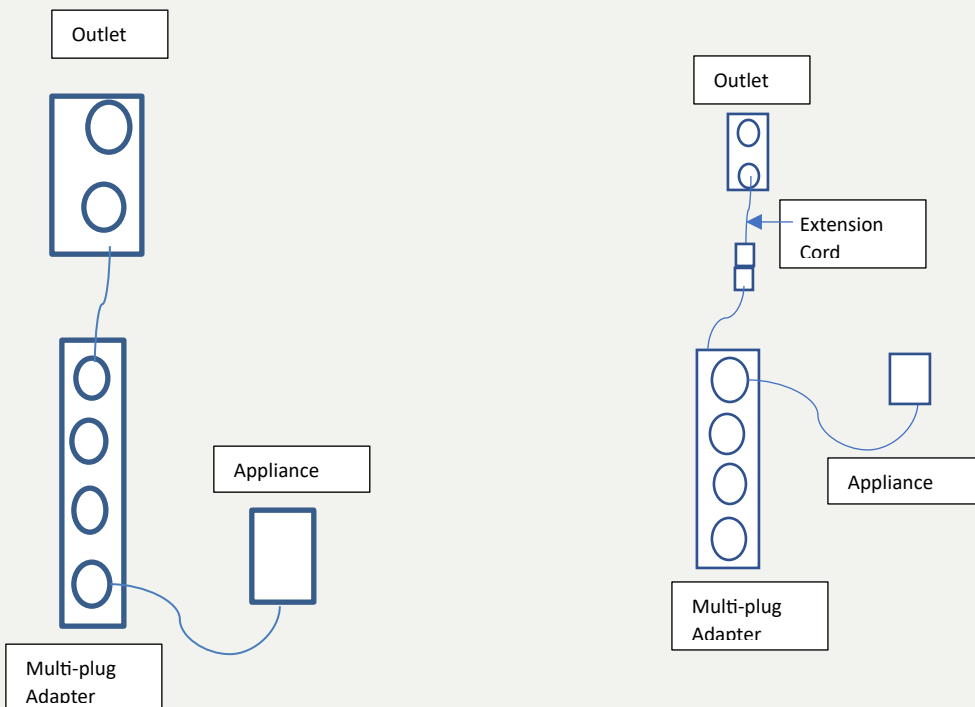

TENTS, CANOPIES, AND MEMBRANE STRUCTURES: GENERAL REQUIREMENTS

Tents, canopies, and membrane structures shall be separated from parked vehicles and internal combustion engines by 20 feet or more. When tents, canopies, and membrane structures are located near a building, exits from either the building or the tent shall not be blocked.

Tents and canopies may be placed side by side in groups of 700 square feet, with a 12-foot fire break between each group.

Tents (pop-up canopy typically 10x10) that are utilized for cooking at events shall meet the following requirements:

- The use of charcoal or wood for cooking shall not be approved under a tent.
- Open flame, defined as a barbeque or any cooking device where the food is cooked directly over a flame, shall be moved from under and away from the tent a minimum of 3 feet.
- Cooking devices located under tents with sidewalls shall have cooking devices located at least 3 feet from the sidewall.
- Tents with or without sidewalls shall have a permanently affixed label with one of the following fire ratings: NFPA 701, CPAI-84, ASTM E84, or the State of California Fire Marshal seal. Tents without a permanently affixed label will be required to remove cooking equipment from under the tent.
- LP gas containers in use for cooking shall be secured from tipping by placing the container(s) in a crate or nesting of 3 or more containers. LP-gas containers not in use shall be secured from tipping by placing the container(s) in a crate or nesting of 3 or more containers and placed outside the tent.
- Fire extinguishers shall be provided for all cooking operations within tents. Cooking equipment involving vegetable, animal oils, fats, and deep fat frying shall have a Class K fire extinguisher. Any other type of cooking operations shall have a 2A:10:B:C or 3A:40:B:C fire extinguisher.

Tents and canopies are not approved to be used inside any fairground building.

ASSEMBLY USES

Under no conditions shall the maximum occupant load established for a building or area be exceeded. Occupant loads may be lowered based on use.

Aisles are required throughout every building, specifically for every exhibit, trade show, or other event. Every occupied portion of a building accessible by the public shall be provided with aisles leading to exits or exit doorways. Aisle width shall not be less than 10 feet as measured from booth edge to booth edge.

In places of assembly or portions without ramped or tiered floors for seating and with greater than 200 seats, the seats shall be fastened together in groups of not less than three, or the seats shall be securely fastened to the floor. IFC 1030.15 exception 3

AISLE REQUIREMENTS FOR ASSEMBLY AREAS WITH SEATING: Minimum clear width for aisles shall be forty-two inches for a level or ramped aisles having seating on both sides. IFC 1030.9 .1(4)

EXCEPTIONS:

- The forty-two inches can be reduced to thirty-six inches, where the aisle serves fewer than 50 seats.
- The forty-two inches can be reduced to thirty inches, where the aisle serves fewer than 15 seats and is not part of the accessibility route.
- The forty-two inches may be reduced to thirty-six inches when the seating is only on one side.

The required aisle widths and locations are established on the approved Setup plan and must always be maintained.

CROWD MANAGERS

Trained crowd managers approved by the fire marshal are required for events with more than 1000 attendees or as required by the Fire Marshal. One crowd manager for every 250 attendees, with no fewer than two crowd managers, is required. Crowd managers must have had training, which the Fire Marshal has approved in the following:

- Conducting fire, life safety, and crowd control inspections
- Identifying and correcting any egress barriers
- Identifying and mitigating any fire hazards
- Ability to verify compliance with all permit conditions, including those governing pyrotechnics and other special effects
- Ability to direct and assist the event attendees in evacuation during an emergency
- Ability to assist emergency response personnel where requested
- Conducting other duties as required by the fire code official
- Conduct other duties as specified in the fire safety plan

Crowd managers shall be readily identified by marked "CROWD MANAGER" or "SECURITY", "EVENT STAFF" vest, shirt, or other material indicating their responsibility and identity. Crowd managers shall have no duties other than crowd management and ensuring safe and orderly exiting during an emergency. Certificates of crowd manager training must be submitted to the Parks office three days before the event.

If you have other questions about your event's setup or operation, please get in touch with the Parks Department at (360) 337-5350 or Fire Marshal staff at (360) 337-5777.