

Serrage bas Ø120 x 1 250 (A0000443)

Low tightening Ø120 x 1 250

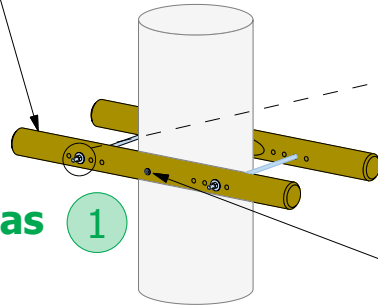

Serrage bas 1

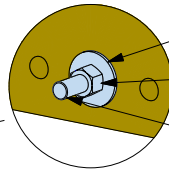

Rondelle L16 mm (A0000932)

Washer L16 mm

Ecrou M16 mm (A0000795)

Nut M16 mm

Tige filetée M16 x 1 000 mm (A0000991)

Threaded rod M16 x 1 000 mm

Vis Ø8 x 180 mm (A0001047)

Screw Ø8 x 180 mm

Serrage haut Ø100 x 1 500 mm (A0000466)

High tightening Ø100 x 1 500 mm

Traverse Ø100 x 1 200 mm (A0000516)

Crossbar Ø100 x 1 200 mm

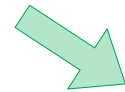

Rondin fraisé Ø120 x 1 500 mm (A0000606)

Log Ø120 x 1 500 mm

Rondin fraisé Ø100 x 3 000 mm

Log Ø100 x 3 000 mm

Vis Ø5 x 70 mm (A0001036)

Screw Ø5 x 70 mm

Demi plateau Ø1 500 mm (A0000133)

Half plate Ø 1 500 mm

Serrage haut 2



Plancher 3

Planche anti-d 35 x 140 x 1 500 mm (A0002389)

Anti-d plank 35 x 140 x 1 500 mm



Le conseil du pro

Professional tips

Différents perçages dans les serrages du haut et du bas pour s'adapter au diamètre des arbres.
 Veuillez à la hauteur de la plateforme par rapport au sol pour éviter que le pan incliné ne devienne trop raide.

Different holes in the upper and lower clamps to adapt to the diameter of the trees
 Pay attention to the height of the platform relative to the ground to prevent the inclined surface from becoming too steep.

Suggestion de montage Construction suggestion

Plateforme pan incliné
 serrage Ø1500

Inclined panel clamping platform Ø1500

