

ADJUSTABLE SPEED GATE CLOSER

Specification Sheet

GSA

FEATURES

- Versatile gate closer capable of closing gates up to 80kg.
- Unique adjusting system which enables the closing speed to be controlled.
- Using the adjustable brackets the force this closer exerts can be altered as required - no need to release gas!



PRODUCT FEATURES

Product Code	Description
GSA	Adjustable speed gate closer
Max gate weight:	80kg
Max gate width:	1.2m
End fittings:	8mm eyes
Finish:	Corrosion resistant black sleeve
Center to center:	600mm
Force:	400N

ADJUSTING THE SPEED

To adjust the gate closing speed, simply twist the grooved wheel on the end of the strut clockwise or anti-clockwise as shown in the picture below. This can be adjusted at any time after installation if needed.

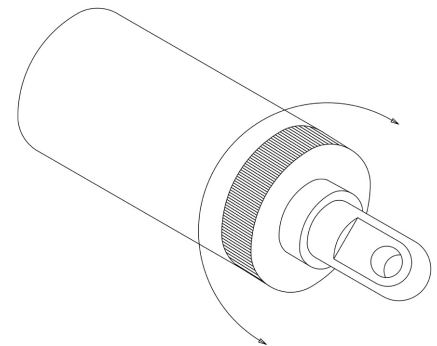

INSTALLATION

1. Fix the brackets supplied so that the geometry relative to the hinge pivot point is as shown in the drawing
2. Fit the adjustable gas spring using the parts supplied.

MAINTENANCE The piston rod is protected by a steel cover tube. The piston rod should not be lubricated or damaged in any way, as this will reduce the life of the seals. Periodically lubricate the ball joints with a light oil and clean the surface of the gas strut with a damp cloth.

