



TRANSPORT & CONSTRUCTION™

Placing Buyers & Sellers In Contact

INFORMATION ON
New and Used Construction
Equipment. Cranes, Forklifts,
Mining Equipment, Parts and
Services, Material Handling
Trucks, Trailers, Busses and
Engineering Equipment



**MARCH
2025**

**VOLUME 31
NO. 3**



C.T.C. PLANT COMPANY (PTY) LTD
SINCE 1992

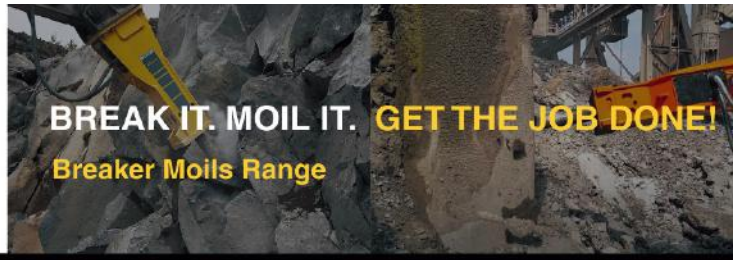

Breaking ground starts with the right tools – Get in touch with Mark today!

Soosan

- SB81 Moils
- SB40 Moils

Furukawa

- F22 Moils

Everdigm

- EHB30 Moils
- EHB20 Moils

CAT

- H160 Moils

Montabert

- V1600 Moils

Bretec

- BA2424 Moils

Rammer

- BR2577 Moils
- G90 Moils
- E66 Moils
- E68 Moils

JCB

- HM160/180 Moils
- HM033T Moils

Atlas Copco

- MB1700 moils
- MB1200 Moils

Epiroc

- MB1700 moils
- MB1200 Moils

Leading supplier of used
earthmoving plant & equipment
in South Africa

Mark Swanepoel

082 825 6966

marks@ctcplant.co.za



www.ctcplant.co.za

Cnr. Michigan &, Manchester St, Airport Industria, Cape Town, South Africa



C. T. C. PLANT COMPANY (PTY) LTD
SINCE 1992



**A leading supplier of used earthmoving
plant & equipment in South Africa**

Excavator



**2015 CAT 323D2L
8 900 Hours**

Dumper



**2015 Bell B20E 6x4
23 000 Hours**

TLB



**2020 BELL 315SL
6 200 Hours**

CONTACT OUR TEAM TODAY!

SCAN ME



Cobus Dreyer

 cobus@ctcplant.co.za

 **+27 73 187 3752**

Peter Groenewald

 peterg@ctcplant.co.za

 **+27 72 368 5581**



www.ctcplant.co.za

Cnr. Michigan &, Manchester St, Airport Industria, Cape Town, South Africa





Hydraulics • Engineering
 “Engineering Africa”

CYLINDER REPAIR AND MANUFACTURE

Africa's Largest Remanufacturer of

HYDRAULIC EQUIPMENT



WE HAVE A COMPREHENSIVE STOCK OF
NEW PARTS AND EXCHANGE UNITS FOR:

- Caterpillar • Komatsu • Volvo • Bell • Rexroth/Hydromatic • Staffa • Kawasaki • Case
- Linde • Sumitomo • Hitachi • Poclain • Sunstrand/Eaton • Vickers • Hyundai • Doosan



CAT 428/424 Pumps
 Bell B20/B25 Pumps
 (NEW & RECON)



VICKERS
 TA1919 Pumps
 (RECON)



KAWASAKI Pumps
 (NEW & RECON)



VICKERS MFE19
 Motors (RECON)

JOHANNESBURG

TEL: +27 11 882 8413
 Clinton: 082 652 8897 | EMAIL: clinton@pex.co.za
 Albertus: 082 658 7301

CAPE TOWN

TEL: +27 21 556 3232
 FAX: +27 21 557 9948
 NICK: 073 173 1597 | EMAIL: nick@pex.co.za

ESP THE PROVEN ALTERNATIVE



MTG Systems

StarMet

No limits innovation

INNOVATIVE HAMMERLESS SYSTEM FOR HEAVY DUTY CONSTRUCTION, QUARRYING AND MINING.

Tooth-adaptor fitting system increasing the productivity of excavators from 60 to 400 tonnes, loaders from 70 to 350 tonnes.

SERIES

- 500
- 240
- 180
- 120
- 60
- 50
- 40

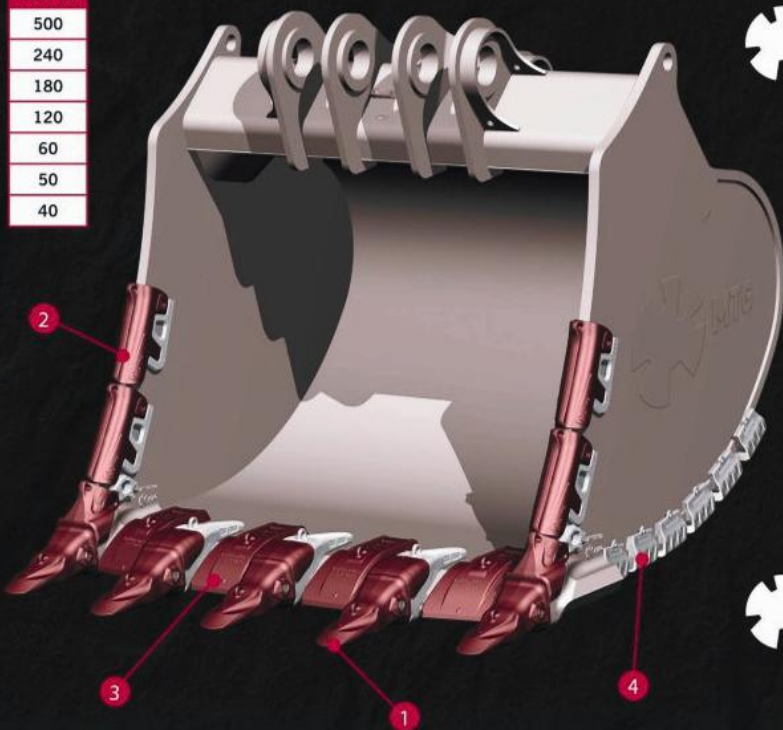

MTG SYSTEMS

STARMET

- 1 TOOTH-ADAPTER SYSTEM



PROMET

- 2 WING SHROUD



PROMET

- 3 LIP SHROUD



MTG PLUS

- 4 HEEL SHROUDS

BENEFIT FROM OUR 9 MONTHS WARRANTY PERIOD ON NEW PARTS

ESP Johannesburg
Tel: (011) 398-1700

ESP Gqeberha
Tel: (041) 484-4575

ESP Bloemfontein
Tel: (051) 432-4501

ESP Kimberley
Tel: (053) 831-8349

ISO 9001 Certified

ESP Cape Town
Tel: (021) 945-1030

ESP Pretoria
Tel: (012) 804-6706

ESP Middelburg
Tel: (013) 246-2520

ESP Pinetown
Tel: (031) 705-4200

www.espa.co.za

ESP THE PROVEN ALTERNATIVE



Multi-brand parts suitable for **KOMATSU** earthmoving machinery



BENEFIT FROM OUR 9 MONTHS WARRANTY PERIOD ON NEW PARTS

ESP Johannesburg
Tel: (011) 398-1700

ESP Gqeberha
Tel: (041) 484-4575

ESP Bloemfontein
Tel: (051) 432-4501

ESP Kimberley
Tel: (053) 831-8349

ESP Cape Town
Tel: (021) 945-1030

ESP Pretoria
Tel: (012) 804-6706

ESP Middelburg
Tel: (013) 246-2520

ESP Pinetown
Tel: (031) 705-4200

ISO 9001 Certified

Manufacturers' names, numbers, symbols and descriptions are used for reference purposes only and it is not implied that any part listed is the product of the manufacturers.

BELL PARTS

Keeping your investment moving

Comprehensive parts support and solutions throughout your ownership journey



BELL
Parts

ORIGINAL PARTS

Premium parts tested and selected to meet our high engineering standards

BETA
Bell Trusted Alternative

ALTERNATIVE PARTS

Replacement parts tested and approved at affordable prices to suit your budget and needs

BELL
ReMan

REMAN PARTS

Remanufactured components to the same standard and specification as new

BELL
Used Parts

USED PARTS

Extensive selection of pre-owned equipment components

NAMPO

Come visit us at
NAMPO 2024 Stand F8
E-mail: bellparts@bellequipment.com

**Strong Reliable Machines
Strong Reliable Support**

BELL

BEL-2102

TURBOFIX

"We are the leaders in the turbocharging field"

Est.
1992



"There is no substitute for quality & service"

Tel: +27 11 814 2299

Fax: +27 11 814 5587

Email: info@turbofix.co.za

Web: www.turbofix.co.za

- Servicing all makes and models of turbochargers.
- Service exchange units of most models of turbochargers in stock.
- All new, repair & service exchange units carry a comprehensive 12 month warranty.
- We collect & delivery countrywide.



5 Second Street, Vorsterskroon Ext 3, Nigel, South Africa



GFA
Gears for Africa

145 Lamp Road , Wadeville Germiston
**OUR QUALITY COMPARES
100% TO ANY OEM SPARE
MANUFACTURES**

MANUFACTURE OF SPIRAL BEVEL GEARS NOW AVAILABLE



Gears For Africa - Petrel Laser Cutting's products include all types of gears, sprockets, splines and related product for industrial and heavy duty equipment and practically all applications related to power drive systems:

- *Bevel Gears* • *Internal & External Splines* • *Worm Gears* • *Helical & Internal Helical Gears*
- *Spur gears* • *Crown Gears*

Carl Nel:

083 657 0522

carl@gearsforafrica.co.za

**PETREL
LASER CUTTING**

Petrel cuts lead times with 15kW fiber laser cutting machine

KEY BENEFITS:

- **Fast Lead Times:** In-house profiling expedites project delivery.
- **High-Quality Results:** Precise cuts with minimal finishing required.
- **Versatility:** Capable of handling various materials & thicknesses.

SPECIALIST OF LASER CUTTING IN MATERIALS:



Stainless steel



Mild steel



Aluminium



Brass



Copper

OUR MARKETS:

- Aerospace
- Construction
- Machining industry
- Automotive industry
- Military
- Agriculture
- Trailer manufactures
- Mining sector
- Fabrication

Michael Nel :

067 003 6633

michael@petrelequipment.com

5 ABIE STR , DUNCANVILLE VEREENIGING

BRADEN CARCO Gearmatic PACCARWINCH

CROWN WHEEL AND PINION, PLANETARY, SUN AND RING GEARS , FINAL DRIVE GEARS, DIFF HOUSINGS SPIDER CROSS KITS, SPIRAL BEVAL GEARS

FOR THE MINING , RAIL , HEAVY EARTHMOVING , BUILDING AND AGRICULTURE INDUSTRIES

WWW.GEARSFORAFRICA.CO.ZA

AUTO COOLING SOLUTIONS_{CC}

- Universal Electric Fans
- Counter Clockwise Fans
- Fan Clutches (viscous)

- Electric Fans
- Fan Blades
- Replacement Units

- Fan Blades
- Replacement Units
- Fan Clutches
- Universal Electric Fans (12V - 10", 12", 14", 16") (24V - 12", 14", 16") etc

For Most Makes of: Motor Vehicles, Pick Ups, Trucks, Busses, Heavy Duty Equipment, Off Road Vehicles

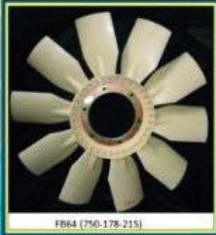

FB64 (750-178-215)

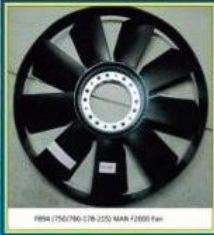

FB64 (750/760-178-255) MAN T2000 Fan



FB1147 (720-180-200) Counter Clockwise Rotation Fan



FB69(610-50-89)Komatsu,Bell,Kato Excavator Fan



FB71 (720-127-152) Volvo and others



FB72 (740-127-153) International, Tata, Volvo Fan



Earthmoving Fan

FB6X(620-35-50)Hercules/Case Mitsuba

ELAINE PIENAAR

Tel: +27 (0) 21 982 7114 / 7116

Cell: +27 (0) 84 681 2513

Email: autocooling@telkomsa.net Web: www.autocoolingsolutions.co.za / www.autofans.co.za
Unit 6 & 7 • 14 Tarentaal Crescent, Okavango Park, Brackenfell, 7560

CARGO

CRANKSHAFT REBUILDING

(Pty) Ltd



www.cargocrankshaftrebuilding.co.za

- ☎ (011) 873 6685
- ☎ 086 509 6789
- ✉ Marcoe@acenet.co.za
- 🏠 21 Main Reef Road, Primrose, Germiston, 1401
- ☎ Marius: 082 452 9700

- Crank and Camshaft Rebuilding
- Crack Detecting
- Straightening
- Balancing
- Repositioning of ADE 400 Series Camgear
- Engine Rebuilding of commercial, earthmoving equipment, and passenger vehicles
- Precision Grinding of shafts up to 2.3m including crankshafts, camshafts, compressors, electrical rotors etc.
- Line Boring
- Dynamometer Tuning Computer
- Diagnostics of all Mercedes Benz truck applications

WE STOCK A LARGE RANGE OF COMMERCIAL & PASSENGER CRANKSHAFTS



STRAIGHTENING

Big and small we straighten them all steel & cast-iron shafts.



BALANCING

Our Cemb ZE II balancing machine can give you a printout of initial & residual unbalance.

CRACK DETECTING

We use ultra violet magnetic particle crack detection. (Crack Test Certificates issued on request)



DYNA TESTING

Dynamometer tuning and computer diagnostics of all Mercedes-Benz truck applications.



Cummins ISX Cylinderhead Injector Tubes Installed, (OE Installation Kit) **NOW AVAILABLE!**

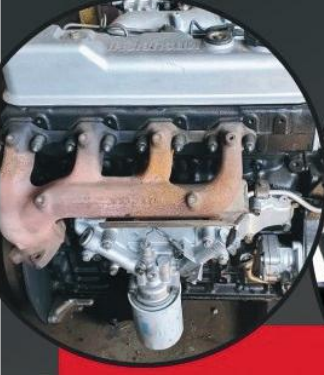

We stock a **LARGE VARIETY** of **GAURANTEED SPARES** for all makes of trucks and commercial vehicles as well as a wide range of **NEW TRUCK PARTS**.

ENGINES:

Ade | Hino | Isuzu | Mitsubishi |
Mazda | Man | Nissan | Toyota |
Cummins | Merc

A LARGE SELECTION OF CABS:

Toyota | Isuzu | Hino |
Scania | Actros

STOCK INCLUDES:

Nissan | Tata | Hino |
Toyota | Axor | Actros | Man |
International | Isuzu

**WE STOCK
NEW AND
USED SPARES**

With over **45 years** experience behind us, we provide our clients with the **best possible advice and service**.

CALL NOW

082 776 8500

www.denvertruckspares.co.za
011 615 7420 | 074 897 7293
Cnr Chilvers & Main Reef Road,
Denver, JHB, 2094, South Africa





ENGINE SPARES

**LINER KITS, GASKET KITS,
VALVES & GUIDES, WATER PUMPS,
OIL PUMPS, CRANK & CAM SHAFTS,
ENGINE BEARINGS AND BUSHINGS**



mitsubishi

KOMATSU

DOOSAN

NISSAN

ISUZU

YANMAR



KAWASAKI PUMPS

NEW AND RECON

FINAL DRIVES

**20 & 30 TON EXCAVATOR
TM40 & TM60 FINAL DRIVE PARTS
& COMPLETE UNITS**



KAWASAKI ROTATING GROUPS

**K3V AND K5V SERIES
INNER PARTS
ROTATING GROUPS AND SEAL KITS**

UNDERCARRIAGE



TRACK LINKS



**TRACK PLATES
BOLTS & NUTS**



SPROCKETS



IDLERS



**TRACK & CARRIER
ROLLERS**

CONTACT US:

**TEL: 011 396 1081
SALES2@SHINLITRADING.CO.ZA
SALES4@SHINLITRADING.CO.ZA
SALES5@SHINLITRADING.CO.ZA**

ADDRESS:

67 HIGH ROAD, BREDELL A/H, KEMPTON PARK





RHINO
Excavator Hammers cc

We Also Do Plant Hire



Hire: 082 887 8636 | Sales: 071 670 8707 / Office: 074 922 2382

sales@rhinohammers.co.za | hire@phplant.co.za | www.rhinoattachments.co.za



EDMAR AGENCIES

The Driving Force In Air Brake Compressors

www.edmar.co.za

082 447 1333 / 076 262 7449

011 616 6150 / 011 615 6391

manny@edmar.co.za

martin@edmar.co.za

Edmar stocks both **new** and **used** compressors, as well as carrying an extensive range of complete repair kits for all types of compressors at competitive pricing.



Yumak



Edmar Agencies is one of South Africa's distributors for one of the world's leading air-brake systems' manufacturers, Turkish giant

CARGO

CRANKSHAFT REBUILDING

We stock a large range of commercial & passenger crankshaft

Now Available

Cummins ISX Cylinderhead injector
tunes installed (OE Installation kit)



SPECIALIZING IN:

- Crank- and Camshaft Rebuilding
- Crack Detecting
- Straightening
- Balancing
- Repositioning of ADE 400 Series Camgear
- Engine Rebuilding of commercial, earthmoving equipment, & passenger vehicles
- Precision Grinding of shafts up to 2.3m incl crankshafts, camshafts, compressors, electrical rotors etc.
- Line Boring
- Dynamometer Tuning Computer Diagnostics of all Mercedes Benz truck applications

BALANCING

STRAIGHTENING

CRACK DETECTING

DYNA TESTING

CONTACT US

🏠 21 Main Reef Road, Primrose, Germiston, 1401

☎ (011) 873 6685

📞 Hendre : 076 791 3927

✉ Workshop@cargocr.co.za

CS MORRITT CC

Wydan Business Park No 58 Road 5 Unit No 4 Brentwood Park BENONI

Celebrating
26
YEARS
of Service

PROFESSIONAL
QUALITY
EXPERIENCED SERVICES



NOW STRIPPING JCB
540-170 & 535-140

USED PARTS

FULLY EQUIPPED WORKSHOP FACILITIES
AND FIELD SERVICE VEHICLES

www.csmorritt.co.za



JCB
Parts & Service Specialists

sales@morrittparts.co.za
082 490 6203 / 011 568 6079

JCB PART SUPPLIER
NEW PARTS



Tel: 072 614 7044 | Carl: 082 490 6203
Dean: 061 441 8540 | Email: csmorritt@gmail.com
parts@csmorritt.co.za / sales@csmorritt.co.za
Fax to Email 086 667 1386

NEW CAPE DEALER
JCB PARTS
WESTERN CAPE BRACKENFELL
TEL 072 065 7466

www.morrittparts.co.za

MORRITT PARTS

Specialising in

EARTH MOVING

Parts & Rebuilds.

We do **Hydraulics repairs** & stock a wide range of parts.



Hydraulics | New & Used Parts | Machine Rebuilds | Service Exchange Units | Field Service

Dominic: **082 961 7639** | dominic@komanco.co.za

Trevor: **082 779 5606** | trevor@komanco.co.za

☎ **011 396 2675**

📍 21 Sim Road, Aston Manor, Kempton Park, Gauteng



KOMATSU

Finaldrives | Pins & Bushes | Buckets | Cabs | Hoses | Electrical | Radiators |
Oil Coolers | Valves | Seal Kits | Gearpumps | Track Adjusters | Undercarriage & More

Sintech

CELEBRATING 40 YEARS



OFF-HIGHWAY CLUTCH, BRAKE AND TRANSMISSION PARTS FROM AN ORIGINAL EQUIPMENT SUPPLIER

JHB: +27 (0)11 823 2359

DUR: +27 (0)31 569 2695

WWW.SINTECH.CO.ZA

sales@sintech.co.za



CMS PRODUCTS

Original Equipment Duo Cones for the Following Brands:

BELL
CATERPILLAR
KESSLER
KOMATSU
VOLVO



And many others - Please contact us to find your nearest stockist

TENNECO www.goetze.africa



Seats for safety and comfort



The **Seat Connection** has been providing seating solutions for all commercial and industrial vehicles for over 30 years.

As an approved agent of well known international brands, our expertise and service levels meet the high standards set by these international companies.

Our products are used in trains, trucks, buses, mining and game viewing vehicles as well as construction equipment and other specialised vehicles.



Air Suspension



KAB 411



Mechanical Suspension



**The seat
CONNECTION**



TheSeatConnection



+27 11 452 6802



info@seatconnection.co.za

[www](http://www.seatconnection.co.za)

www.seatconnection.co.za



www.camattachments.com

THE PK-TS FORK POSITIONER: POWER AND PRECISION IN EVERY MOVEMENT



CONTACT US

TVH PARTS SOUTH AFRICA (PTY) LTD • HEAD OFFICE JOHANNESBURG

90 Electron Avenue • Isando • Kempton Park 1600 • South Africa • GPS S -26.130318, E 28.214541
T +27 11 281 2700 • F +27 11 392 3599 • sales.southafrica@tvh.com • www.tvh.com

CAPE TOWN

4 Buchan Street
Stikland Industrial
Bellville, Cape Town 7530
T +27 21 988 2432

DURBAN

5 Peterson Place
Westmead
Pinetown 3600
T +27 31 100 0760

LICHTENBURG

Shop 1
103 Scholtz Street
Lichtenburg 2740
T +27 18 632 6192/6092

PORT ELIZABETH

220 Commercial Road
Sidwell
Port Elizabeth 6001
T +27 41 453 1404/8

RICHARDS BAY

Unit 3 Ferro Park
1 Ferro Gang Road • Alton
Richards Bay 3900
T +27 35 751 1001

Jumanje

POWER PARTS

SERVICE AND YOUR DOWNTIME IS OUR PRIORITY.
WE WILL ENDEAVOUR TO FIND WHAT YOU NEED!

AUTOMOTIVE • HEAVY DUTY • CONSTRUCTION
AGRICULTURAL • MINING • GENERATORS

25 YEARS CUMMINS EXPERIENCE
FOR YOUR CUMMINS ENGINE COMPONENTS

NOW IN STOCK

• Mid-tier range on 4/6 B and 6C Series
• QSB 6.7 | QSC | QSL | ISB | ISF | ISC | L8.9/L9/L10 Series
• Selected ISX15 | QSX15 | NTAB55/855 | N14 | M11
• New ISF2.8/ISF3.8 | QSF2.8/QSF3.8 | 833 | QSB 4.5

PLUS A WIDE RANGE OF BPK BELTS AND FILTERS

CONTACT US FOR
UNBELIEVABLE
PRICING AND SERVICE

Follow us on Facebook:
www.facebook.com/jumanje4u

CARRADINE VARKEVISSER

Tel: 011 976 1242 | Cell: 060 525 9943
Cell: 063 753 6466

Email: sales@jumanje.co.za

Jumanje
POWER PARTS

PRO-HYD

Import & Export



Servicing the industry for more than 30 years, Pro-Hyd meets every hydraulic need. Repairs are undertaken in a fully equipped workshop that adheres to OEM standards and testing. Pro-Hyd is a multi-branded company and one of the largest independent stockists related to PARTS & SERVICES for the industrial, construction and commercial industry.

Parker **Rexroth** **NACHI** **EATON** **SAUER DANFOSS**
Bosch Group HYDRAULIC EQUIPMENT

Also Stockist of seal kits for the above brands



MANUFACTURES AND SUPPLIERS OF HYDRAULIC AND ENGINEERING PRODUCTS

Hydraulics and Engineering

VICKERS • NACHI • STAFFA • CATERPILLAR • BELL • VOLVO
• KAWASAKI • SUNDSTRAND • DANFOSS • KOMATSU

CONTACT US

✉ Info@pro-hyd.co.za www.pro-hyd.co.za
☎ 066 471 4915
📍 111 10th Road, Kew, Johannesburg
☎ (011) 882-8104/5/6

Tel: 011 868 5130
Fax: 086 634 7904
Cell: 071 684 5784

MZANTSI

TRANSMISSIONS



We offer specialised transmission repairs for heavy duty & on highway machines

- BELL
- TEREX
- DESMOND
- HITACHI
- DAEWOO
- ZF
- ALLISON
- CLARK
- FUNK

info@gearboxes.me
6 van der Bijl
Alrode South
Alberton

WE OFFER **DYNO TESTING** ON **ZF TRANSMISSIONS**

YOUR TRUSTED PARTS SUPPLIER

FOR EARTHMOVING AND AGRICULTURAL MACHINERY



ENGINE PARTS, AXLE PARTS,
TRANSMISSIONS AND MORE...



CARRARO Spare Parts Authorized Dealer

*We supply original & quality replacement parts!
Covering more than 130 brands!*

SINCE 2013



www.LNE-AgriEarth.com

+27 (0)861 888 008 | +27 (0)83 327 3237 (A/H)

LNE@LNE-AgriEarth.com

@LNEAgriEarth



CARRARO

Spare Parts
Authorized Dealer

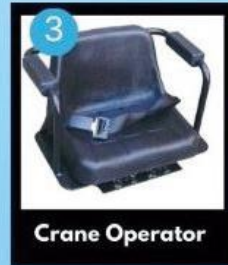

Contact person: Johan Brits

Tel. (051) 435 4752 or (051) 435 4450

Email: permaseating@mweb.co.za

Website: www.permaseating.co.za

58 Tannery Road,
Hamilton,
Bloemfontein,
South Africa

PERMA
SEATING
SINCE 1985

TRACTOR/INDUSTRIAL SEATS

Driver 520 Seat

Weight Adj Suspension



Air Suspension
Upholstered



Mech Suspension
PU Cushions

- Air or Mechanical Suspension
- Upholstered or PU Cushions

Driver 640 Seat

Weight Adj Suspension



Air Suspension
Upholstered



Mech Suspension
PU Cushions

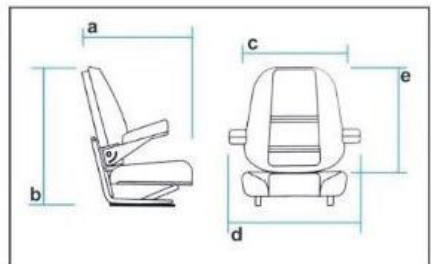

Seat	a	b	c	d	e
520 Susp Seat	620	830	520	680	530
640 Susp Seat	650	870	410	590	610

Exclusive Distributor for Swedish Lorry Parts in Southern Africa

Tel (011) 918 1397/8
E-Mail:sales@slpsa.co.za
www.slpsa.co.za



SLP South Africa

WE DON'T DO "CHEAP"

WE DO QUALITY



Power Transmission

Transmission Pumps, Gasket Sets, Gears, Propshafts, Universal Joints, Hub Seals, Final Drive and Axle Parts, Wheel Nuts and Studs

Engine Parts

Engine Rebuild Kits, Gasket Sets, Oil Pumps, Inlet and Exhaust Valves and Components, Water Pumps and Repair Kits, Cylinder Liner Sets

Suspension & Frame

H Frame Pins and Bushes, Miscellaneous Pins for Excavators, Dust Seals, Scrapers, Hollow Springs, Suspension Rubbers, Shock Absorbers

Braking System

Brake Discs, Accumulators, Brake Lining Sets, Repair Kits Mineral Oil and Brake Fluid, Pedals, Master Cylinders, Wet Brake Discs

Swedish Manufactured Replacement Parts for Volvo Mining, Truck, Bus, Penta Marine and Industrial applications.

New range of Scania parts available

STOCK UP FOR A STRESS-FREE SEASON



IN STOCK NOW

TRAVEL REDUCTIONS



EC750D (VOLVO)



ZX870 (HITACHI)



ZX470 (HITACHI)

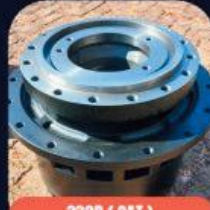

330D (CAT)



- ✓ **Radiators and Oil Coolers:** DX225, DX300, EC210, S220, S300.
- ✓ **Bucket Pins and Bushes:** to suit most 20T, 30T and 40T excavators.
- ✓ **Toggle Links:** to suit most 20T and 30T excavators.
- ✓ **Main Hydraulic Pumps:** K3V-K5V series & HPV102,118,145 pumps.
- ✓ **Main Hydraulic pump parts:** All internal parts & seal kits for the K3V, K5V, HPV & HPK300 pumps. We also stock regulators, EPPR Valves & pilot pumps.
- ✓ **Pump Couplings:** Couplings H type, A type & AS type.
- ✓ **Swing motors:** DX225, S220, SH210, JS205. We also stock internal parts & seal kits on the M2X & M5X series.
- ✓ **Swing Reductions:** To suit 20 ton up to 75 ton.
- ✓ **Track Adjusters:** CAT 329D, CAT 320, SH200, SH300, DX300, EC210, EC460, PC200-7, R210LC-7, R220LC-9S, ZX200-3, ZX330-5, ZX200-5G, S220/225, DX225, JS205.
- ✓ **Final Drive Travel Devices Available:** CAT330D, CAT320D2, 20T Travel Device, EC300 (Volvo), EC380D, ZX670, EC480.
- ✓ **RCV levers:** complete for the Doosan DX & Solar Series.

WE STOCK A WIDE RANGE OF NEW EXCAVATOR PARTS TO KEEP YOUR EQUIPMENT RUNNING SMOOTHLY. IF WE DON'T HAVE WHAT YOU NEED, WE'LL SOURCE IT FAST TO MINIMISE DOWNTIME



+27 11 967 0060

SALES@MIDPLANT.COM

BREDELL, KEMPTON PARK

Tel: 011 868 5130
Fax: 086 634 7904
Cell: 071 684 5784

MZANTSI TRANSMISSIONS



- BELL
- TEREX
- DESMOND
- HITACHI
- DAEWOO
- ZF
- ALLISON
- CLARK
- FUNK

**We offer specialised transmission
repairs for heavy duty & on
highway machines**



info@gearboxes.me
6 van der Bijl
Alrode South
Alberton

WE OFFER DYNO TESTING ON ZF TRANSMISSIONS

Generating the **DEUTZ** way. **DEUTZ DIESELPOWER**

*Invest In Engineering
Excellence!*

*Renowned Quality At
Affordable Prices!*

Please contact our sales department
for prices covering our complete Diesel
Generator range.

Telephone No: +27 (011) 923 0600
Email: jaco@deutz.co.za
info@deutz.co.za

Check out our website for the full
DEUTZ product range:

Website: www.deutz.co.za

Demand Original DEUTZ Products and Services

The engine company.



"Mobile energy generation - we do it right!"



076 861 7609



ATSE

ALL TERRAIN
SERVICES & EQUIPMENT (PTY)



Piet@atse.co.za

SAKAI SOIL COMPACTORS:



SV521/621 Series with
Cabin



SV900-1 Series



SV900-1 Series

SAKAI ASPHALT ROLLERS:



R2H Series



R2-2/R2-2K



Soil Stabilizer and Cold Recycler
PM550-s

SAKAI LIGHT EQUIPMENT:



HV/HS Series



PC Series

ATSE is a reputable company specializing in the importation, marketing, & selling of specialized equipment for the all terrain industry. We have established ourselves as a trusted partner, delivering high-quality products & innovative solutions that cater to the unique needs of our customers

011 029 8600
www.at-southafrica.com



17 SPARTAN ROAD, SPARTAN
KEMPTON PARK, 1619

Engine & Transmission Spares & Rebuilding

100% Guaranteed fast and
reliable services

SECOND HAND SPARES

E & A SPARES

(PTY) Ltd



E-mail: easpares@iafrica.com



SPECIALISTS IN:

Rebuilding of DETROIT Engines (GM)

DETROIT

ALLISON



CLARK

Rebuilds of Transmissions for ALLISON - ZF - CLARK

(031) 700 5791 / 082 659 5521 - Deva

UNIT 5, CENTRAL PARK, 24 KYALAMI ROAD,
WESTMEAD ext, PINETOWN, DURBAN 3608

ENGINE DEN

012 386 2786 - 072 784 5352
076 247 4015 - 083 578 6861



Fax: (012) 386 1786
Email: engineden@wol.co.za
www.engineden.co.za

Mon - Fri @ 8:00 AM to 4:45 PM
Sat @ 8:00 to 12:30 PM
Friday we are closed between 12 and 2 PM

DIRECT IMPORTERS OF NEW AND USED ENGINES, GEARBOXES AND SPARES



ADE 352/366 Cylinder Head Complete From R6 500
Incomplete From R5 500
Atego EVB 906 Cylinder Head bare From R12 950



352/366 Piston with Ring From R325 (each)
352/366 Rings From R45 (each)
Mahle Pistons 904/906 From R595 (each)



422 V8 Turbo Used Engine From R45 000
442 V8 Turbo Used Engine From R55 000



ADE 352/366 Sleeves Only From R65
422/442 From R195 407/447 From R220
Atego Sleeves 904/906 From R195



Main Bearing 366/352 From R450
Big End Bearing 352/366 From R95
Mains 407/447 STD 10th/20th From R225
Atego Main Sputter STD
904/624/906/926 From R95 Each
Atego Main Sputter 10th
904/624/906/926 From R115 Each
Atego Main Sputter 20th
904/924/906/926 From R135 Each



HUBNER
ADE 352/366 New Bare Blocks From R17 500
ADE 352/366 Sub Assembly (New) From R27 500



Atego Water Pump 904/906
From R1 950



ADE 442 T/71 Sputter Big Ends From R295
447 T/71 Sputter Big Ends From R275
Atego Sputter Big Ends STD
904/924/906/926 From R149 Each
Atego Sputter Big Ends 10th
904/924/906/926 From R155 Each
Atego Sputter Big Ends 20th
904/924/906/926 From R175 Each



407 Starter From R1 950
ADE 352/366 12V New Starter From R1 500
ADE 352/366 24V New Starter From R1 500



ADE 352/366 Turbos From R2 950
407/447 Turbos From R4 950
ADE 314/364 Turbos From R3 450
422/442 Turbos From R2 750



352/366 Full Gasket Set From R550
407/447, 422/442 Bottom Sets From R395
400 Series Head Sets From R69
Atego 904 Full Set Gasket Set From R1 750



352/366 Head Bolts From R590
400 Series Head Bolts From R95



ADE 352/366 Oil Pump New From R795
Atego Oil Pump BF 904/906 From R1 500
Atego Original Oil Pump From R2 650



ADE 300 Series Compressor Belt Driven From R2 950
ADE 300 Series Compressor Cam Driven From R1 500

WE WILL BEAT ANY WRITTEN QUOTATION



ALL ENGINES
ARE SOLD ON
EXCHANGE

ADE 366N
P.O.A
ADE 366 TI
P.O.A
ADE 364N
P.O.A
ADE364T
P.O.A



ALL ENGINES
ARE SOLD ON
EXCHANGE

Cummins 6BTI
P.O.A



MAN D0826
P.O.A

Block OM 447/407 BF
P.O.A
Block OM 541 V6
P.O.A
Block OM 542 BF
P.O.A
Block ADE 422/442
P.O.A
Block ATEGO 904/906
P.O.A



ALL ENGINES
ARE SOLD ON
EXCHANGE

Actros 541-V8
P.O.A

Actros 542-V8
Engine
P.O.A



ALL ENGINES
ARE SOLD ON
EXCHANGE

Atego 906 New Engine
P.O.A
Atego 904
P.O.A
Atego 906
P.O.A
Atego 906 Gearbox G100
P.O.A



ADE 352 Crank BF From R6 500
ADE 366 From R6 500
ADE 407/447 Crank new From R14 500
ADE 364 Crank From R6 500

Atego Crank 904
(98mm/103mm) From R11 500
Atego Crank 906
(98mm/103mm) From R11 500
Atego Crank 924
From R14 500
Atego Crank 926
From R14 500
BF Germany 442/422
Crank new From R9 500
Crank Shaft OM 501 BF
From R19 500

311 Stephenson Road
Pretoria West Industrial Area (Behind Iscor)
Pretoria West
0117

CASH OR BANK GUARANTEED CHEQUES ONLY
EFT/CREDIT/DEBIT CARDS WELCOME

ALL PRICES EXCLUDING VAT
*Subject to availability & price



SECUR-A-NUT WHEEL SECURITY SYSTEM

The crime rate leaves no one untouched and criminals have discovered an easy source of income: Expensive truck tyres and rims. Until now, there was very little that could be done. However the amazingly simple SECUR-A-NUT Wheel Security System stops all would be thieves in their tracks.



SECUR-A-NUT WHEEL SECURITY SYSTEM MEANS:

- No more stolen wheels and Rims
- No Down time caused by unscheduled replacement of wheel assemblies
- Wheel & Tyre security at the fraction of the cost of replacement
- Quick and Easy fitment
- Peace of mind



SIMPLE & EASILY AFFORDABLE

Manufactured and hardened steel, the SECUR-A-NUT Wheel Security System quickly & cost effectively reduces wheel theft as the wheel assembly simply cannot be removed without your unique corresponding SECUR-A-SOCKET.

We manufacture to our patented design, which includes your unique registered pattern number, for Nuts & Sockets that meet your vehicles requirements.

TESTED FOR YOUR SECURITY

The SECUR-A-NUT Security System has had rigorous tests done on both the nut and the socket and results showed they easily withstood well in excess 750Nm of torque without loosening. The strength of the system was confirmed by withstanding more than 50 tightening and loosening cycles without any sign of damage.



www.advancedtransmissions.co.za

DIRECT IMPORTERS OF HEAVY DUTY GEARBOX AND DIFFERENTIAL PARTS

Replacement parts for the following manufacturers:
DAF, Eaton, Fuller, MAN, Mercedes-Benz, Rockwell, Scania, Volvo and ZF.

Parts are ISO9002 approved and imported from Italy, Germany and USA

Parts include - Seals, Bearings, Brake Discs & Pads, Suspension Components & Front Axles, Hydraulic PTO's and Pumps, Switches & Valves



WE SPECIALISE IN THE REPAIR OF ALL HEAVY DUTY GEARBOXES AND DIFFERENTIALS AT OUR JOHANNESBURG BRANCH

New & Exchange Units available with a 1 year Warranty

JOHANNESBURG
459 Flower Close,
Sam Green Road
Tunney Ext 9, Germiston

Tel: +27 11 822 2221
Fax: +27 11 822 2216

**NOW IN STOCK:
CROWNWHEEL & PINIONS
FOR TOYOTA QUANTUM
AND HILUX/FORTUNER**

PINETOWN
Unit 7 Techni Park
29 Hillclimb Road
Westmead, Pinetown

Tel: +27 31 700 5905
Fax: +27 31 700 5911

KRON

+27 (0) 76 861 7609

info@kron-sa.co.za

www.kron-sa.co.za

CONSTRUCTION EQUIPMENT

MOTOR GRADER



Motor grader KRÖN G12



MOTOR GRADER KRÖN G14



MOTOR GRADER KRÖN G16

CRAWLER EXCAVATOR



CRAWLER EXCAVATOR KRON
EX210



CRAWLER EXCAVATOR KRON
EX310



Crawler excavator KRON
EX520

ROAD ROLLER



ROAD (PNEUMATIC) ROLLER
KRON PR16



ROAD ROLLER
KRON HR325



ROAD ROLLER (SOIL) KRON
SC22

H.V.R TURBOS



WE ARE THERE FOR YOU CALL, WE DO!

KOOP & VERKOOP

GRONDVERSKUIWINGSMASJINERIE
TROKKE, SLEEPWAENS, VURKHYSERS
EN BOORMASJIENE
OP

WWW.HVRTURBOS.CO.ZA

HENNING

083 755 2177



UPGRADE YOUR SHIPPING EXPERIENCE



We are a level 1 B-BBEE value added contributor offering end-to-end air, sea & land logistics services.

www.synergyworldwidelogistics.co.za

Worldwide Logistics Excellence



- OCEAN
- AIR
- LAND
- PROJECT MANAGEMENT
- CUSTOMS
- MARINE INSURANCE
- NVOCC
- SUPPLY CHAIN FINANCE

Head Office - Durban
107 Escom Road, New Germany,
Durban
Tel: +27 31 7057909

Johannesburg Office
Unit 1 - Isando Business Park
Cnr Gewel & Hulley Road
Isando
Tel: +27 11 3971180

Cape Town Office
1st Floor No 4 Canal Side,
Heron Crescent, Century City,
Cape Town
Tel: +27 21 4256664



EARTHMOVING TRANSMISSION REPAIRS

32 Golden Drive, Unit 1, Benoni, 1501

We specialize in repairing transmissions for a wide range of heavy-duty machinery, ensuring that your equipment operates at its best

EXCHANGE UNITS ON ZF 4WG200 AVAILABLE

CAT, SDLG, SHANTUI, SANY, LUIGONG, TEREX, HITACHI,
KOMATSU AND SO MUCH MORE

JHB HEAD OFFICE
Office Contact - Karina - 079 079 7791
Sales Contact - Karen - 076 103 1224
Specialist Contact - James - 079 079 7124

FASTRAKTRANSMISSIONS@OUTLOOK.COM





C.T.C. PLANT COMPANY (PTY) LTD
SINCE 1992

Phone: +27 21 300 2291
Email: info@ctcplant.com

PLANT EQUIPMENT FOR SALE



SALES AND SUPPORT OF USED EARTH MOVING PLANT & EQUIPMENT WORLDWIDE

CS MORRITT CC

Wydan Business Park No 58 Road 5 Unit No 4 Brentwood Park BENONI

NOW STRIPPING JCB
540-170 & 535-140

USED PARTS

celebrating
26
YEARS
Of Service

**PROFESSIONAL
QUALITY
EXPERIENCED SERVICES**



**FULLY EQUIPPED WORKSHOP FACILITIES
AND FIELD SERVICE VEHICLES**

www.csmorritt.co.za



sales@morrittparts.co.za
082 490 6203 / 011 568 6079

JCB PART SUPPLIER NEW PARTS

Tel: 072 614 7044 | Carl: 082 490 6203
Dean: 061 441 8540 | Email: csmorritt@gmail.com
parts@csmorritt.co.za / sales@csmorritt.co.za
Fax to Email 086 667 1386

NEW CAPE DEALER
JCB PARTS
WESTERN CAPE BRACKENFELL
TEL 072 065 7466

www.morrittparts.co.za

MP MORRITT PARTS

TURBOFIX

Est. 1992



Turbofix management & staff would like to thank all our customers for 25 years of loyal support. We look forward to assisting you with all your future turbocharger needs.

"There is no substitute for Service & Quality"

We are the leaders in the turbocharging field



Formula 1 FACTS



A Formula One car can accelerate from zero to 160 kph in just four seconds.

The first official Formula One season took place in 1950, marking the beginning of this prestigious racing competition.

In the 2016 season, the Williams team sets the pit stop record taking just 1.92 seconds to remove the 4 used tires and install a new rubber tire.

The height between the floor of an F1 car and the asphalt varies between 1 and 5 cm, which is the thickness of a modern smartphone.

To build an F1 car, it takes nearly 80,000 expensive parts and 150,000 hours of human labor. For this reason, its construction cost is over 5 million dollars.

Bell ReMan Parts & Components

for **JCB**
Backhoe Loaders

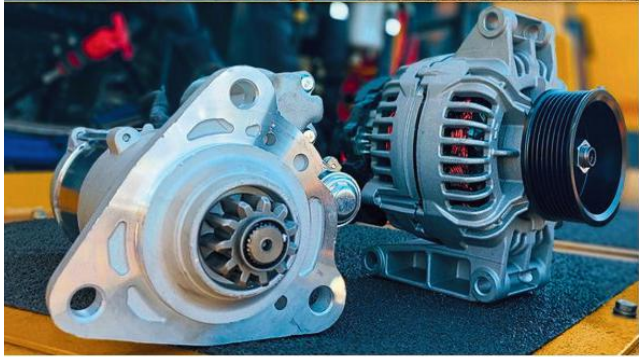

Aftermarket Mining & Construction Parts

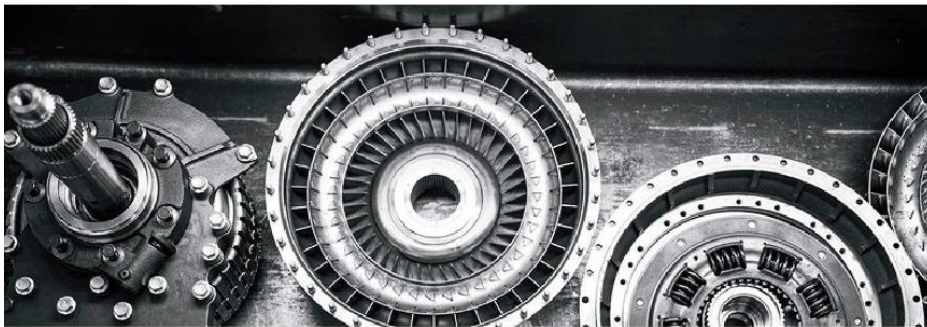

BELL
South Africa

Used Mining & Construction Parts & Equipment

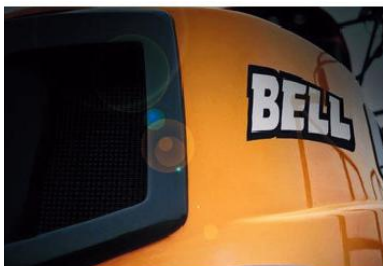

Contact your nearest Bell Customer Service Centre to discover more.

ALL PRICES EXCL. VAT | VALID WHILE STOCKS LAST | E&OE.

FOLLOW US ON    

E-mail: bellparts@bellequipment.com
www.bellequipment.com

Strong Reliable Machines
Strong Reliable Support

BELL

145 Lamp Road, Wadeville, Germiston



GFA

Gears for Africa

OUR QUALITY COMPARES 100%
TO ANY OEM SPARE
MANUFACTURES

011 824 2017

MANUFACTURE OF SPIRAL BEVEL GEARS NOW AVAILABLE

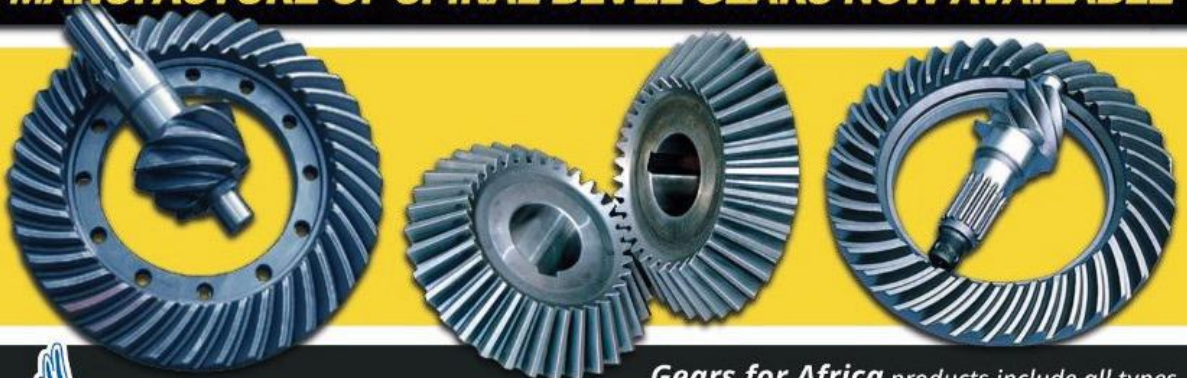

PETREL
INTERNATIONAL
ESTD 1947

Gears for Africa products include all types of gears, sprockets, splines and related products for industrial and heavy duty equipment and practically all applications related to power drive systems:

- Bevel Gears • Spur Gears • Worm Gears
- Helical & Internal Helical Gears
- Crown gears • Internal & External Splines

Petrel International Official Distributors of: Braden/Paccar Winch

BRADEN CARCO Gearmatic

PACCAR WINCH

**CROWN WHEEL AND PINION, PLANETARY, SUN AND RING GEARS
FINAL DRIVE GEARS, DIFF HOUSINGS SPIDER CROSS KITS, SPIRAL BEVEL GEARS**

**FOR THE MINING, RAIL, HEAVY EARTH MOVING, CONSTRUCTION
AND AGRICULTURAL INDUSTRIES**



083 657 0522

carl@gearsforafrica.co.za
www.gearsforafrica.co.za

Tel: 011 824 2017
Fax: 011 420 3314

INCREASE YOUR SALES

Our Printed Publication
reaches over

12,000

People

Our Promotional Emails
reaches over

35,000

People

Our Newsletter reaches
over

45,000

People

Our Publications reaches
over

45,000

People

||

Contact us to
promote your
company now!



About Our Company

Welcome to TRANSPORT & CONSTRUCTION™ We have a Broad Publishing Market Footprint that has made us Experts in creating, publishing and disseminating content to engage audiences and successfully Place Buyers and Sellers in Touch, for 29 years.

We Partner innovative and interactive Media Platforms, to consistently create a strong focus, Powerfully Promoting our Clients, across all aligned Industry Landscapes.

LET'S CONNECT

Phone

044 382 1606

Website

transportandconstruction.co.za

Email

Finance@lloydsgroup.net

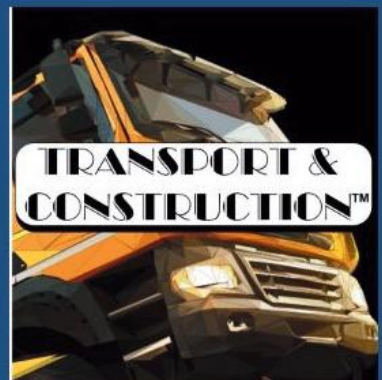



Hydraulics • Foundry • Engineering

“ Engineering Africa “

CYLINDER REPAIR AND MANUFACTURE HYDRAULICS



FOUNDRY



We remanufacture hydraulic pumps, motors, cylinders and control valves as well as the supply of hydraulic hoses and equipment and the design and manufacture of hydraulic systems across a wide spectrum of industries inclusive of construction, mining, agriculture, civil and marine.



CAT 428/424 Pumps
Bell B20/B25 Pumps
(NEW & RECON)



KAWASAKI Pumps
(NEW & RECON)



Hydraulic Piston
Rotating Pumps



VICKERS
TA1919 Pumps
(RECON)



VICKERS
MFE19 Motors
(RECON)



Piston pumps



PEX HYDRAULICS: JOHANNESBURG
TEL: +27 11 882 8413

PEX HYDRAULICS: CAPE TOWN
TEL: +27 21 556 3232

OTHER BRANCHES IN LUANDA, SPRINGBOK,
FOUNDRY, NAMIBIA ANGOLA, ZAMBIA, ZIMBABWE,
KITWE & MOZAMBIQUE

All manufacturer's names, numbers and descriptions are for reference purposes and do not imply that components listed are of manufacturers referred to



SINCE 2013



Agri Earth

www.LNE-AgriEarth.com

+27 (0)861 888 008 | +27 (0)83 327 3237 (A/H)

LNE@LNE-AgriEarth.com

@LNEAgriEarth

CARRARO

Spare Parts
Authorized Dealer



Tel: +27 (0)11 923-0600
Fax: +27 (0)11 923-0687
E-mail: info@deutz.co.za
Website: www.deutz.co.za

DEUTZ DIESELPPOWER

National phone number: 08610 33889 / 08610 DEUTZ



Stick with the authorised **DEUTZ** Product and Service experts for all your service and genuine* **DEUTZ** spare parts and engines.

*Please be aware of non-genuine engines & parts being passed off as DEUTZ. If in any doubt please contact us. Please contact us about our product range & services. We can help you get the best out of your DEUTZ engines.

The engine company.



WE OFFER SPECIALISED TRANSMISSION REPAIRS FOR HEAVY DUTY & ON HIGHWAY MACHINES

BELL • TEREX • DESMOND • HITACHI • DAEWOO • ZF • ALLISON • CLARK • FUNK

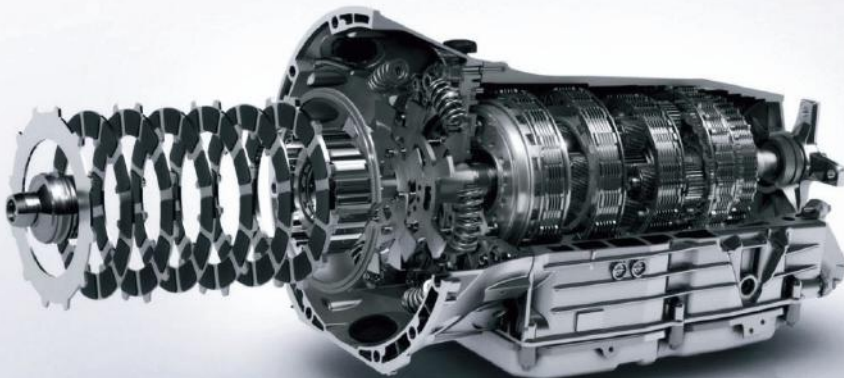

Tel: 011 868 5130
Fax: 086 634 7904
Cell: 071 684 5784

MZANTSI
TRANSMISSIONS

Mahindra
Rise.



C.T.C. PLANT COMPANY (PTY) LTD
SINCE 1992

Mahindra RoadMaster G90 Motor Grader



**Built for Tough Terrain,
Engineered for Precision.**

Mahindra EarthMaster VX90 4WD



**This wheel loader is built for
every challenge.**

CONTACT OUR TEAM TODAY!

SCAN ME



Cobus Dreyer

 cobus@ctcplant.co.za

 +27 73 187 3752

Peter Groenewald

 peterg@ctcplant.co.za

 +27 72 368 5581

   www.ctcplant.co.za

Cnr. Michigan &, Manchester St, Airport Industria, Cape Town, South Africa



edcomps@mweb.co.za / 011 615 6391
011 616 6150

VISION

We see ourselves as one of the leading compressor company's in South Africa. Our goal is to further extend our reach around South Africa and the rest of Africa as we continue to build the company to ensure that we can provide old, and new companies, with the best possible service as we build long - term relationships with our clients.

SERVICES

Edmar Agencies are committed to providing our customers in our unique market with the care and attention that you deserve. Our customers always come first and our knowledgeable sales and workshop staff are on hand to provide top quality service and aftersales technical support.

OWNER
Jason Humphries:
082 951 1611
edmarag@mweb.co.za

www.edmar.co.za

SALES
Manny Silva:
082 447 1333
edcomps@vodamail.co.za
Martin Makhanye:
076 262 7449
martin@edmar.co.za

322 Jules Street, Malvern, Johannesburg 2094



EDMAR AGENCIES
The Driving Force In Air Brake Compressors

HVR Turbos

📍 Parkweg Street 2, Boshof, Freestate, SA.

KOOP & VERKOOP
WWW.HVRTURBOS.CO.ZA



**GRONDVERSKUIWINGSMASJINERIE,
TROPKE, SLEEPWAENS, VURKHYSERS
EN BOORMASJIENE.**



HENNING: 0837552177

henning@hvirturbos.co.za



Plasings

Ons herbou en herstel ook diesel turbos,
tel op en lewer af met een dag diens en een
jaar waarborg.

YOU SHOULD BE WITH US

We place buyers and sellers in touch .
We do it all for your business, marketing your business to the fullest .



**TRANSPORT &
CONSTRUCTION™**



044 382 1606



www.transportandconstruction.co.za



Finance@lloydsgroup.net

Sintech



CLARK DANA AXLE, BRAKE & TRANSMISSIONS

JHB: +27 (0)11 823 2359

DUR: +27 (0)31 569 2695

WWW.SINTECH.CO.ZA

sales@sintech.co.za



CARGO

CRANKSHAFT REBUILDING

We stock a large range of commercial & passenger crankshaft

Now Available

Cummins ISX Cylinderhead injector
tunes installed (OE Installation kit)



SPECIALIZING IN:

- Crank- and Camshaft Rebuilding
- Crack Detecting
- Straightening
- Balancing
- Repositioning of ADE 400 Series Camgear
- Engine Rebuilding of commercial, earthmoving equipment, & passenger vehicles
- Precision Grinding of shafts up to 2.3m incl crankshafts, camshafts, compressors, electrical rotors etc.
- Line Boring
- Dynamometer Tuning Computer Diagnostics of all Mercedes Benz truck applications

BALANCING

STRAIGHTENING

CRACK DETECTING

DYNA TESTING

CONTACT US

21 Main Reef Road, Primrose, Germiston, 1401

(011) 873 6685

Hendre : 076 791 3927

Workshop@cargocr.co.za

We offer specialised transmission repairs for heavy duty & on highway machines

• BELL • TEREX • DESMOND • HITACHI • DAEWOO
• ZF • ALLISON • CLARK • FUNK



We Offer Dyno Testing On ZF Transmissions

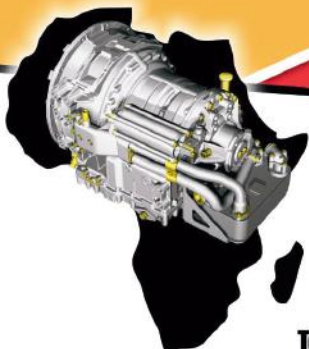

MZANTSI

TRANSMISSIONS

Tel: 011 868 5130 Fax: 086 634 7904 Cell: 071 684 5784

info@gearboxes.me

6 van der Bijl
Alrode South
Alberton



PARTS AND ACCESSORIES FOR SMALL EARTH-MOVERS

With more than **5 million known references**, TVH can provide the widest range of parts for small earth-movers on the market, including tracks, undercarriage parts, filtration, hydraulics, tyres, electrical parts, engine parts, and much more.

Suitable for all major makes on the market, including: **Bobcat, Case, aterpillar, JCB, John Deere, Kubota, Takeuchi, Volvo, Yanmar ...**



WWW.TVH.COM/BACKHOE

TVH PARTS SOUTH AFRICA (PTY) LTD - HEAD OFFICE JOHANNESBURG

90 Electron Avenue • Isando • Kempton Park 1600 • South Africa • GPS S -26.130318, E 28.214541
T +27 11 281 2700 • F +27 11 392 3599 / +27 11 974 9845 • sales.southafrica@tvh.com • www.tvh.com

CAPE TOWN

4 Buchan Street
Stikland Industrial
Bellville, Cape Town 7530
T +27 21 988 2432
F +27 21 988 9127

DURBAN

5 Peterson Place
Westmead
Pinetown 3600
T +27 31 100 0760
F +27 31 700 6191

LICHTENBURG

Shop 1
103 Scholtz Street
Lichtenburg 2740
T +27 18 632 6192/6092
F +27 18 632 6108

PORT ELIZABETH

220 Commercial Road
Sidwell
Port Elizabeth 6001
T +27 41 453 1404/8
F +27 41 453 1409

RICHARDS BAY

Unit 3 Ferro Park
1 Ferro Gang Road • Alton
Richards Bay 3900
T +27 35 751 1001
F +27 86 530 3145

PERMA SEATING

Reg. No.98/21213/07 (PTY)LTD

The Original Moulded Polyurethane Industrial Seat Manufacturer

The leader in the development and manufacturing of innovative seating systems.



- Transport •Construction •Mining •Earthmoving Equipment
- Forklift /Handling • Forestry •Military •Agriculture



STEELBACK T-BACK SUSPENSION

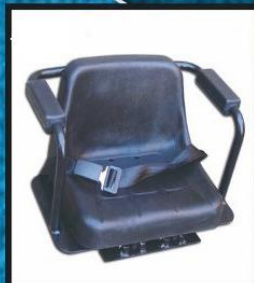

CRANE OPERATOR SEAT



SUSPENSION / DUMPER



UNIVERSAL



ARMY SEAT CUSHIONS



300 mm (wide)

SEAT CUSHIONS



BRICK CRANE SEAT



Max. height 200mm
Min. height 80mm

HEIGHT ADJUSTER

Buy direct from factory for the best prices!

64 Tannery Road, Hamilton, Bloemfontein, South Africa
PO Box 35643 Faunasig 9325

Contact person: Johan Britz

Tel: (051) 435-4752 or 435-4450 | Fax: (051) 435-4753

e-mail: permas@mweb.co.za | website: www.permaseating.com



RHINO
Excavator Hammers cc



Office: 074 922 2382 | Hire: 082 887 8636 | Sales: 071 670 8707

We Also Do Plant Hire



sales@rhinohammers.co.za | hire@phplant.co.za
www.rhinoattachments.co.za

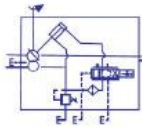

PRO-HYD
Import & Export (Pty) Ltd

Reg. No. 82/08907/07
Manufacturers and Suppliers of Hydraulic
and Engineering Products

<<< JUST LANDED >>>
SEAL KITS

For the following pumps and motors ...



MS08, MS11 & MS18
Wheel Motors



Kawasaki K3V63, K3V112,
K3V140 & K3V180DT,
K5V140, K5V200DPH/DTH

Rexroth MCR Wheel
Motors



Rexroth A4VG90



Rexroth
Bosch Group

Eaton PVH98



Rexroth A8V107,
A8V160 & A8V200



Liebherr LPVD64



CAT 120G & 140G
Pumps

Did You Know ?

The name "Sintech" is in turn an abbreviation of 'Sintered Technology' which when applied to friction material is at the **heart** of the range of products we continue to serve.



Did You Know ?

Advanced Transmissions are confident in providing readily available, quality components at **cost effective prices** to you, our valued customer.



Did You Know ?

LNE Agri Earth is a authorised Carraro Parts dealers.



Did You Know ?

The journey of Cargo Crankshaft Rebuilding started in 1994 as a small engineering workshop focusing on crank- and camshaft rebuilding..

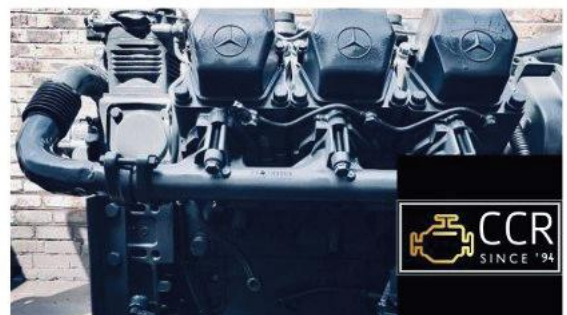

Exclusive Distributor for Swedish Lorry Parts in Southern Africa

Tel (011) 918 1397/8
E-Mail:sales@slpsa.co.za
www.slpsa.co.za



SLP South Africa

WE DON'T DO "CHEAP"

WE DO QUALITY



Power Transmission

Transmission Pumps, Gasket Sets, Gears, Propshafts, Universal Joints, Hub Seals, Final Drive and Axle Parts, Wheel Nuts and Studs

Engine Parts

Engine Rebuild Kits, Gasket Sets, Oil Pumps, Inlet and Exhaust Valves and Components, Water Pumps and Repair Kits, Cylinder Liner Sets

Suspension & Frame

H Frame Pins and Bushes, Miscellaneous Pins for Excavators, Dust Seals, Scrapers, Hollow Springs, Suspension Rubbers, Shock Absorbers

Braking System

Brake Discs, Accumulators, Brake Lining Sets, Repair Kits Mineral Oil and Brake Fluid, Pedals, Master Cylinders, Wet Brake Discs

Swedish Manufactured Replacement Parts for Volvo Mining, Truck, Bus, Penta Marine and Industrial applications.

New range of Scania parts available

Specialising in

EARTH MOVING

Parts & Rebuilds.

We do **Hydraulics repairs** & stock a wide range of parts.



Hydraulics | New & Used Parts | Machine Rebuilds | Service Exchange Units | Field Service

Dominic: **082 961 7639** | dominic@komanco.co.za

Trevor: **082 779 5606** | trevor@komanco.co.za

☎ 011 396 2675

📍 21 Sim Road, Aston Manor, Kempton Park, Gauteng



KOMATSU

Finaldrives | Pins & Bushes | Buckets | Cabs | Hoses | Electrical | Radiators |
Oil Coolers | Valves | Seal Kits | Gearpumps | Track Adjusters | Undercarriage & More

SAVE

HERE'S HOW TO DIESEL FUEL IN HEAVY EQUIPMENT

For people who operate heavy equipment, saving money on fuel is always a top priority. While trucks and other machines do critical work, they can be expensive and wasteful to operate; companies and operators alike have begun to turn their attention to fuel-saving devices and other ways to lower emissions and boost efficiency.

Fortunately, it is possible to promote fuel savings for heavy equipment, just so long as operators know how to approach it.

Fuel Savings for Heavy Equipment: 5 Tips

Heavy equipment is often used for everything from remodeling a home to clearing snow from a blocked roadway. These five smart tips can help promote fuel efficiency:

1. Limit Idle Times

During startup and shutdown, many operators let their equipment idle for several minutes; unfortunately, this is a primary cause of fuel waste. In recent years the engine mechanisms used in large equipment have advanced rapidly, allowing heavy machinery to warm up and cool down much faster. As a result, it is no longer necessary to idle engines for long periods. Limiting idle times can help reduce fuel consumption and slash environmental pollution at the same time.

2. Drive Slower

Driving heavy machinery at high speeds destroys fuel economy and can cause emissions to spike. To cut down

on this situation, operators can regulate their driving speeds and take their time getting heavy equipment from one place to another.

3. Keep Tires in the Proper Pressure Range

Tire pressure has a large impact on fuel economy, and maintaining proper tire pressure is critical to maintaining efficient operation. For best results, operators should have tire pressure inspected on a regular basis and adjust them accordingly.

4. Implement Efficient Communication Between Teams

On busy job sites, one smart way to keep fuel economy at its peak is to ensure all heavy equipment teams are communicating effectively with one another. This helps prevent excess idling and can cut down on the total run time of each piece of machinery.

5. Shift at Lower RPM

Gearing up and throttling down at high RPMs can destroy fuel economy, so operators should always be careful to reduce RPMs before they shift.

Better Fuel Economy Starts Here

While there's no way around the fact that heavy equipment uses a great deal of fuel, these smart tips can help create fuel savings for heavy equipment and make machine operation a more efficient experience. What's more, they can also reduce overall dependence on fossil fuels and cut down on environmental pollution, which makes the world a nicer place to live for everyone.



JOHANNESBURG (Head Office)

459 Flower Close

Sam Green Road

Tunney Ext. 9, Germiston

Tel: 011 822 2221 /

011 010 9000

PINETOWN

Unit 7 Techni Park

29 Hillclimb

Westmead, Pinetown

Tel: 031 700 5905 /

031 655 3000



Some of our products and services that we offer:



Rockwell Parts, Eaton Parts & Fuller Parts



ZF Parts

**Repairs to all heavy duty
gearboxes and differentials
are done at our JHB branch**



Volvo Parts



Scania Parts



**Mercedes-Benz
Parts**

AUTO COOLING SOLUTIONS_{CC}

For Most makes of: Motor Vehicles, Pick Ups, Trucks, Busses,
Heavy Duty Equipment, Off Road Vehicles

- Fan Blades
- Fan Clutches(viscous)
- Replacement Units
- Aluminum Spacers
- Vibration Dampers
- Universal Electric Fans
- Counter Clockwise Fans
- Electric Fans



- Fan Blades
- Replacement Units
- Fan Clutches
- Universal Electric Fans (12V-10",12",14",16")(24V-12",14",16") ect

Elaine Pienaar

Tel: + 27 (0) 21 982 7114 / 7116

Cell: + 27 (0) 84 681 2513



Email: autocooling@telkomsa.net Web: www.autocoolingsolutions.co.za / www.autofans.co.za
Unit 6 & 7 • 14 Tarentaal Crescent, Okavango Park,Brackenfell, 7560

"So why did you get fired?"





www.denvertruckspares.co.za
011 615 7420 | 074 897 7293
Cnr Chilvers & Main Reef Road
Denver, JHB, 2094, South Africa



TRUCK AND CAB CLEARANCE

LOCAL AND IMPORTED CABS

FROM **R 7 500.00 EXC VAT.**

ACTROS | TGA | ISUZU IMPORTS | FUSO IMPORTS |
UD290 IMPORTS | DAF



CMS PRODUCTS

Original Equipment Duo Cones for the Following Brands:

BELL
CATERPILLAR
KESSLER
KOMATSU
VOLVO



And many others - Please contact us to find your nearest stockist

TENNECO www.goetze.africa



The Road to Recovery

THE BELL GRAMMER SEAT CYCLE

Damaged Bell Grammer Seat



Dust cover fitted and seat fully restored.



Mechanisms stripped from the seat. Parts thoroughly checked, tested and repaired or replaced.



Seat suspension repaired to operational order.



The seat CONNECTION

Mechanisms rebuilt and suspension re-assembled. Awaiting upholstery.



The **Seat Connection** specialises in the complete mechanical repair and rebuild of original Bell Grammer operator seats.

Standing the test of time, our expertly refurbished truck seats offer reliability, affordability, keeping your driver safely on the road.

Over 30 years of service and product knowledge makes us the seating company you can trust.

011 452 6802
info@seatconnection.co.za
www.seatconnection.co.za
102 8th Ave, Edenvale, Gauteng

APRIL 2025 ESKOM ELECTRICITY INCREASE

HOW MUCH MORE YOU'LL PAY AFTER APRIL 2025 ESKOM ELECTRICITY HIKE



An April 2025 Eskom electricity tariff hike will see prices increase by 12.7% from next week, Tuesday 1 April 2025. No, this is no April Fool's joke. Unfortunately, the April 2025 Eskom electricity price hike has been approved for some time now. But that will be scant consolation when the financial pressure comes to bare on households already struggling to make ends meet.

Despite public outcry, the National Energy Regulator of South Africa (NERSA) approved the April 2025 Eskom electricity hike, citing the utility's need to recover operational costs and address its massive debt burden. So, how much more will average South Africans have to fork out when the 12.7% tariff increase takes effect next week?

Furthermore, the current average Eskom tariff is approximately R2.20 per kWh. An April 2025 Eskom electricity hike sees it increase to R2.48 per kWh. Therefore, a household consuming 500 kWh per month will see their electricity bill rise from R1 100 to approximately R1 240, or R140 per month.

Metered customers face a more complex calculation as their bills include both fixed charges and consumption-based rates. A typical middle-income household with a conventional meter currently pays around R1 500. However, after the April 2025 Eskom electricity hike, they can expect to pay approximately R1 690, an additional R190 per month, or R2 280 annually.

Tel: 031 705 5050
Cell:083 412 1039
Fax: 031 705 5298
Email: aron@pexkzn.co.za
5 Van der Bijl Road, New Germany
LEVEL 2 - B-BBEE

PEX GROUP

Manufactured by:
Pex Engineering

SECUR-A-NUT WHEEL SECURITY SYSTEM

The crime rate leaves no one untouched and criminals have discovered an easy source of income: Expensive truck tyres and rims. Until now, there was very little that could be done. However the amazingly simple SECUR-A-NUT Wheel Security System stops all would be thieves in their tracks.

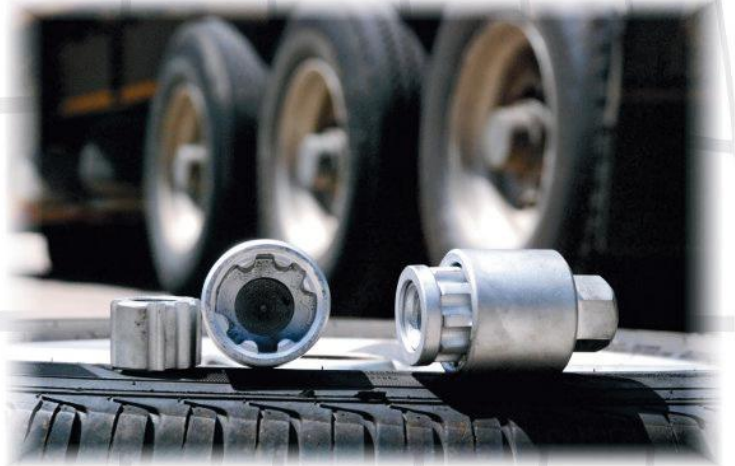

SECUR-A-NUT WHEEL SECURITY SYSTEM MEANS:

- No more stolen wheels and Rims
- No Down time caused by unscheduled replacement of wheel assemblies
- Wheel & Tyre security at the fraction of the cost of replacement
- Quick and Easy fitment
- Peace of mind



SIMPLE & EASILY AFFORDABLE

Manufactured and hardened steel, the SECUR-A-NUT Wheel Security System quickly & cost effectively reduces wheel theft as the wheel assembly simply cannot be removed without your unique corresponding SECUR-A-SOCKET.

We manufacture to our patented design, which includes your unique registered pattern number, for Nuts & Sockets that meet your vehicles requirements.

TESTED FOR YOUR SECURITY

The SECUR-A-NUT Security System has had rigorous tests done on both the nut and the socket and results showed they easily withstood well in excess 750Nm of torque without loosening. The strength of the system was confirmed by withstanding more than 50 tightening and loosening cycles without any sign of damage.

CAPE TOWN'S FIRST SKY CIRCLE CONSTRUCTION TO BEGIN IN MARCH 2025



Cape Town's first sky circle construction to begin in March 2025

The construction of Cape Town's first elevated Sky Circle is set to commence later this month, marking a significant milestone in the city's urban mobility landscape.

To facilitate the project, the signalised intersection at Govan Mbeki Road (M9) and Jan Smuts Drive (M17) in Lansdowne will be temporarily converted into a traffic circle over the weekend of 15 March 2025.

A large crane will be installed at the centre of the traffic circle, and road users are advised to avoid the intersection during this period due to expected lane closures and traffic delays.

This Sky Circle, the first of its kind in South Africa, is a crucial component of the MyCiTi bus service expansion, designed to connect Mitchells Plain and Khayelitsha with Wynberg and Claremont.

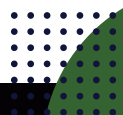

311 Stephenson Road, Pretoria Industrial, Pretoria West, 0117
engine1den@wol.co.za - www.engine1den.co.za

083 578 6861 (012) 386 2786

@engine1den



ADEPART

Switch To

**ENGINE
DEN**

And Save

ADE 352-366 Oil Filter



ADE 352-366 Fan Plastic



ADE 352-366 Turbos



ADE Crank 314-364



**AND
MANY
MORE!**

ADE 352-366 Pistons



ADE 352 Conrod



ADE 352-366
Big-Ends



ADE 352-366 Cylinder
Head Complete



ADE 422-442



Turbo Camshaft

ADE 352-366 Rings



ADE 352-366 Head
Bolts Set



ADE 352-366
24V/12V Starters



ADE 352-366 Cam Followers



ADE 352-366 Head Gasket Set



PRICES EXCLUDE VAT. E & O EXCEPTED. VALID WHILE STOCKS LAST. WE RESERVE THE RIGHT TO LIMIT QUANTITIES. MANUFACTURER'S NAMES, NUMBERS, PHOTOS ARE USED FOR REFERENCE PURPOSES ONLY & STOCKISTS OF THE BRANDS INDICATED.



EARTHMOVING TRANSMISSION REPAIRS

32 Golden Drive, Unit 1, Benoni, 1501



We specialize in repairing transmissions for a wide range of heavy-duty machinery, ensuring that your equipment operates at its best

EXCHANGE UNITS ON ZF 4WG200 AVAILABLE

CAT, SDLG, SHANTUI, SANY, LUIGONG, TEREX, HITACHI,
KOMATSU AND SO MUCH MORE

JHB HEAD OFFICE

Office Contact - Karina - 079 079 7791

Sales Contact - Karen - 076 103 1224

Specialist Contact - James - 079 079 7124

FASTRAKTRANSMISSIONS@OUTLOOK.COM

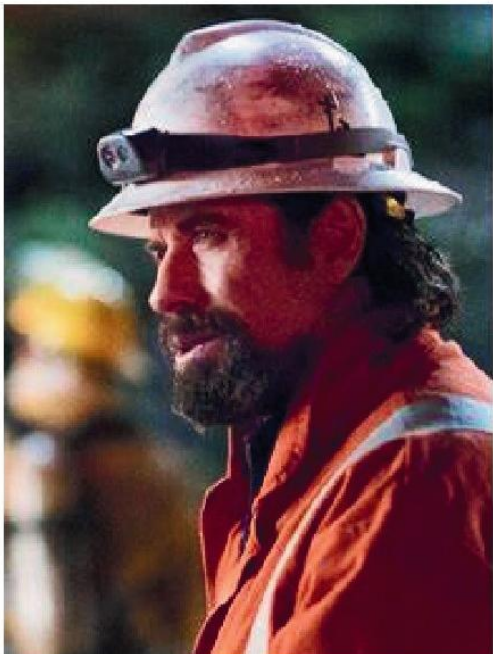

"You guys
wanna hear
a construction
joke? Hold on,
I'm working on it"

H.V.R TURBOS



WE ARE THERE FOR YOU CALL, WE DO!

KOOP & VERKOOP

GRONDVERSKUIWINGSMASJINERIE
TROKKE, SLEEPWAENS, VURKHYSERS
EN BOORMASJIENE
OP

WWW.HVRTURBOS.CO.ZA

HENNING

083 755 2177



UPGRADE YOUR SHIPPING EXPERIENCE



We are a level 1 B-BBEE value added contributor offering end-to-end air, sea & land logistics services.

www.synergyworldwidelogistics.co.za

Worldwide Logistics Excellence



- OCEAN
- AIR
- LAND
- PROJECT MANAGEMENT
- CUSTOMS
- MARINE INSURANCE
- NVOCC
- SUPPLY CHAIN FINANCE

Head Office - Durban
107 Escom Road, New Germany,
Durban
Tel: +27 31 7057909

Johannesburg Office
Unit 1 – Isando Business Park
Cnr Gewel & Hulley Road
Isando
Tel: +27 11 3971180

Cape Town Office
1st Floor No 4 Canal Side,
Heron Crescent, Century City,
Cape Town
Tel: +27 21 4256664



EARTHMOVING TRANSMISSION REPAIRS

32 Golden Drive, Unit 1, Benoni, 1501

We specialize in repairing transmissions for a wide range of heavy-duty machinery, ensuring that your equipment operates at its best

EXCHANGE UNITS ON ZF 4WG200 AVAILABLE

CAT, SDLG, SHANTUI, SANY, LUIGONG, TEREX, HITACHI,
KOMATSU AND SO MUCH MORE

JHB HEAD OFFICE
Office Contact – Karina - 079 079 7791
Sales Contact – Karen – 076 103 1224
Specialist Contact – James – 079 079 7124

FASTRAKTRANSMISSIONS@OUTLOOK.COM





SLP South Africa

We don't do "cheap" we do
QUALITY!

**Swedish Manufactured Replacement Parts for Volvo Mining,
Truck, Bus, Penta Marine and Industrial applications.**

New range of Scania parts available



ENGINE

Lubricating system
Fuel system
Fuel system, gas
Inlet/Outlet system
Cooling system
Engine controls
Ignition & control system
Other engine, EGR system

ELECTRICAL SYSTEM AND INSTRUMENTATION

Battery mountings
Alternator
Starter motor
Lighting
Other electrical equipment
Wiring & fuses
Instruments, contacts & sensors
Other, electrical

BRAKES

Wheel brake
Hydraulic brakes
Parking brake
Air brakes
Trailer brake control
Brake other

CAB, INTERIOR

Cab framework
Grille, foot step, fenders
Door
Windows, mirrors
Seat, seat underframe
Bumpers
Climate system
Interior equipment

POWER TRANSMISSION

Clutch, torque converter
Gear box hydraulic
Gear box
Hydrostatic system
Propeller shaft
Rear axle, CE front axle
Differentials
Power take-off
Other gear box

FRONT AXLE STEERING

Front axle truck/bus
Steering axle
Steering
Rear wheel & boggie suspension
Lever steering
Other suspension

FRAME, SPRINGS, WHEELS AND HUBS

Frame
Suspension
Frame joint
Axle suspension
Shock absorbers, anti-roll bar
Wheel & hub

OTHER EQUIPMENT

Hydraulic system
Mechanical equipment
Electrical auxiliary
equipment
Material handling
Load handling
Excavating system
Grading system



Street Address:

Unit 14 South
Anvil Park
133 Craig Road
Anderbolt
Boksburg
1459

Contact Details:

Tel: +2711 918 1397/8
Fax: 086 241 0044
Inquiries: sales@slpsa.co.za
After Hours: 082 453 1079

Postal Address:

P.O. Box 11397
Aston Manor
1630

☎ 011 814 2299
🌐 www.turbofix.co.za
✉ info@turbofix.co.za

TURBOFIX

Est. 1992



www.turbofix.co.za

📍 5 Second Street, Vorsterskoon Ext3, Nigel, South Africa

“We are leaders in the turbocharging field”

- Servicing all makes and models of turbochargers.
- Service exchange units of most models of turbochargers in stock
- All new repair & service exchange units carry a comprehensive 12 month warranty.

We collect & deliver
countrywide!



“There is no substitute for Quality
& Service”



Best Quality and Service Guaranteed
TURBOFIX

011 029 8600
www.at-southafrica.com



17 SPARTAN ROAD, SPARTAN
KEMPTON PARK, 1619

**Engine &
Transmission
Spares & Rebuilding**

100% Guaranteed fast and
reliable services

SECOND HAND SPARES

**E & A
SPARES**
(PTY) Ltd



E-mail: easpares@iafrica.com



SPECIALISTS IN:

Rebuilding of DETROIT Engines (GM)

DETROIT

ALLISON



CLARK

Rebuilds of Transmissions for ALLISON - ZF - CLARK

(031) 700 5791 / 082 659 5521 - Deva

UNIT 5, CENTRAL PARK, 24 KYALAMI ROAD,
WESTMEAD ext, PINETOWN, DURBAN 3608



SHIN LI
TRADING (CC)

ENGINE SPARES



**LINER KITS, GASKET KITS,
VALVES & GUIDES, WATER PUMPS,
OIL PUMPS, CRANK & CAM SHAFTS,
ENGINE BEARINGS AND BUSHINGS**



MITSUBISHI

KOMATSU

DOOSAN

NISSAN

ISUZU

YANMAR



KAWASAKI PUMPS

NEW AND RECON

FINAL DRIVES

**20 & 30 TON EXCAVATOR
TM40 & TM60 FINAL DRIVE PARTS
& COMPLETE UNITS**



KAWASAKI ROTATING GROUPS

**K3V AND K5V SERIES
INNER PARTS
ROTATING GROUPS AND SEAL KITS**

UNDERCARRIAGE



TRACK LINKS



**TRACK PLATES
BOLTS & NUTS**



SPROCKETS



IDLERS



**TRACK & CARRIER
ROLLERS**

CONTACT US:

TEL: 011 396 1081

SALES2@SHINLITRADING.CO.ZA

SALES4@SHINLITRADING.CO.ZA

SALES5@SHINLITRADING.CO.ZA

ADDRESS:

67 HIGH ROAD, BREDELL A/H, KEMPTON PARK

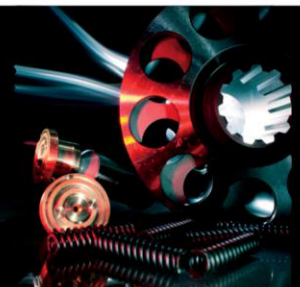

H.V.R TURBOS



WE ARE THERE FOR YOU CALL, WE DO!

KOOP & VERKOOP

GRONDVERSKUIWINGSMASJINERIE
TROPKE, SLEEPWAENS, VURKHYISERS
EN BOORMASJIENE
OP

WWW.HVRTURBOS.CO.ZA

HENNING

083 755 2177



UPGRADE YOUR SHIPPING EXPERIENCE

We are a level 1 B-BBEE value added contributor offering end-to-end air, sea & land logistics services.



www.synergyworldwidelogistics.co.za

Head Office – Durban

107 Escom Road, New Germany,
Durban
Tel: +27 31 7057909

Cape Town Office

1st Floor No 4 Canal Side,
Heron Crescent, Century City,
Cape Town
Tel: +27 21 4256664

Johannesburg Office

7 Covora Road, Jet Park,
Boksburg,
Johannesburg
Tel: +27 11 3971180



WE WANT TO MEET YOU

With over 27 years of global logistics expertise, we have set ourselves apart as a family-oriented premier end-to-end logistics provider that puts our customers' interests at heart.

In addition to our full service offerings, we offer comprehensive marine insurance, supply chain financing, customs specialisation and project management.

SUCCESS TOGETHER WITH AND ALIKE

MORE TONS, LESS DOWNTIME THE 893 DELIVERS!



POP-OUT FEATURES

VERSATILE AGGRESSIVE SCREEN BOX CAN BE EASILY ADAPTED TO SUIT MANY APPLICATIONS.

MODULAR CONFIGURATION SCREEN BOX WITH 6.1M X 1.8M (20' X 6') TOP DECK AND 5.5M X 1.8M (18' X 6') BOTTOM DECK SCREEN.

SCREEN BOX ANGLE CAN BE HYDRAULICALLY ADJUSTED TO AN ANGLE BETWEEN 14 - 18°

THE FINLAY 893 SCREEN IS ENGINEERED TO DELIVER SUPERIOR SCREENING PERFORMANCE, EFFICIENCY, AND DURABILITY, MAKING IT AN EXCELLENT CHOICE FOR INDUSTRIES SUCH AS MINING, CONSTRUCTION, AND RECYCLING.

BELL
South Africa

Proudly selling
& supporting

FINLAY
A TEREX BRAND

TRANSPORT & CONSTRUCTION™

INDEX

AGRICULTURAL/FORESTRY

EQUIPMENT

ATSE- services & Equipment	27
CMS Products	25
CTC Plant Company	IFC
Equipment Spare Parts	20,21
H.V.R Turbos	29
Jumanje Diesel Parts	16
KRON	28
LNE Agri Earth (Pty) Ltd	17
Perma Seating	18,19
Pro- Hyd	20
Synergy WWL	29
TVH PARTS SA	15

AIRBRAKES/BRAKES/

AIRBAGS

ATSA Compressors	27
Denver Truck Spares	8
Edmar Agencies	10
Sintech	13
SLP South Africa	23

ATTACHMENTS

ATSE- services & Equipment	27
CMS Products	25
CS Morrirt	11
CTC Plant Company	IFC
EHD Components	14
Machinery Contractors	2,3,4,45
Pro- Hyd	20

CIVILS/CONCRETE EQUIPMENT

ATSE- services & Equipment	27
Capital Plant Parts	30
CMS Products	25
CS Morrirt	11
CTC Plant Company	IFC
H.V.R Turbos	29
Pro- Hyd	20
Synergy WWL	29

CONSTRUCTION/

EARTHMOVING

EQUIPMENT

ATSE- services & Equipment	27
Bell Equipment	4
Capital Plant Parts	30
CMS Products	25
CS Morrirt	11
CTC Plant Company	IFC
Denver Truck Spares	8
Equipment Spare Parts	20,21
H.V.R Turbos	29
Jumanje Diesel Parts	16
KRON	28
Komanco	12
LNE Agri Earth (Pty) Ltd	17
Gears for Africa	6
Perma Seating	18,19
Pex Hydraulics (Pty) Ltd	1
Pex Hydraulics (KZN)	31
Rhino Hammers	10
Senwes (John Deere)	29
Sintech	13
Synergy WWL	29

CRUSHING/MINING

EQUIPMENT

ATSE- services & Equipment	27
Bell Equipment	4
Capital Plant Parts	30
CMS Products	25
CTC Plant Company	IFC
Denver Truck Spares	8
Equipment Spare Parts	20,21
H.V.R Turbos	29
Perma Seating	18,19
Pex Hydraulics (Pty) Ltd	1
Pex Hydraulics (KZN)	31
Rhino Hammers	10
Shin Li Trading cc	9
Sintech	13

(DRIVE-TRAIN)

CLUTCHES/GEARBOXES

TRANSMISSIONS

Advanced Transmission	32
Denver Truck Spares	8
E&A Spares	26
Equipment Spare Parts	20,21
Gears for Africa	6
Midplant Services	24
Mzantsi Transmissions	22
Shin Li Trading cc	9
Sintech	13
SLP South Africa	23
Synergy WWL	29

ENGINE

ATSE- services & Equipment	27
Cargo Crankshaft Rebuilding	7
Denver Truck Spares	8
Deutz Diesel Power	22
E & A Spares	26
Equipment Spare Parts	20,21
H.V.R Turbos	29
Jumanje Diesel Parts	16
Komanco	12
LNE Agri Earth (Pty) Ltd	17,56
Gears for Africa	6
Pex Hydraulics (Pty) Ltd	1
Pex Hydraulics (KZN)	31
Senwes (John Deere)	29
Shin Li Trading cc	9
SLP South Africa	23
Synergy WWL	29

FANS/COOLING SYSTEMS

Auto Cooling Solutions	7
------------------------	---

FUELS/LUBRICANTS

Denver Truck Spares	8
Deutz Diesel Power	22
Jumanje Diesel Parts	16

GENERATORS/

COMPRESSORS

ATSA Compressors...	26
ATSE- services & Equipment	27
Deutz Diesel Power	22
H.V.R Turbos	29

HYDRAULIC EQUIPMENT

ATSE- services & Equipment	27
Komanco	12
Midplant Services	24
Pex Hydraulics (Pty) Ltd	1
Pex Hydraulics (KZN)	31
Pro- Hyd	20
Rhino Hammers	10
Shin Li Trading cc	9
Sintech	13
SLP South Africa	23



30 YEARS

WORKING FOR YOU



TRANSPORT & CONSTRUCTION™

LIFTING EQUIPMENT

ATSE- services & Equipment	27
Perma Seating	18,19
Pro- Hyd	20
TVH PARTS SA	15

MACHINE HIRE

CTC Plant Company	IFC
TVH PARTS SA	15
Synergy WWL	29

PARTS

ATSA Compressors	26
ATSE- services & Equipment	27
Auto Cooling Solutions	7
Advanced Transmission	32
Bell Equipment	4
Capital Plant Parts	30
Cargo Crankshaft Rebuilding	7
CMS Products	25
CS Morrirt	11
CTC Plant Company	IFC
Denver Truck Spares	8
Deutz Diesel Power	22
E & A Spares	26
Edmar Agencies	10
Equipment Spare Parts	20,21
Gears for Africa	6
	12
Komanco	28
KRON	16
Jumanje Diesel Parts	17
LNE Agri Earth (Pty) Ltd	24
Midplant Services	18,19
Perma Seating	1
Pex Hydraulics (Pty) Ltd	31
Pex Hydraulics (KZN)	11
Precision Diesel	20
Pro- Hyd	10
Rhino Hammers	29
Senwes (John Deere)	9
Shin Li Trading cc	13
Sintech	23
SLP South Africa	29
Synergy WWL	25
The seat connection	5,BC
Turbofix	15
TVH Parts SA	

SEATS/ACCESSORIES

ATSE- services & Equipment	27
Perma Seating	18,19
The Seat Connection	25

SERVICES

ATSA Compressors	27
ATSE- services & Equipment	27
Auto Cooling Solutions	7
Bell Equipment	4
Capital Plant Parts	30
Cargo Crankshaft Rebuilding	7
CS Morrirt	11
CTC Plant Company	IFC,38
Denver Truck Spares	8
Deutz Diesel Power	22
E&A Spares	26
Edmar Agencies	10
Equipment Spare Parts	20,21
Gears for Africa	6
Komanco	12
Midplant Services	24
Mzantsi Transmissions	22
Pex Hydraulics (Pty) Ltd	1
Pex Hydraulics (KZN)	31
Pro- Hyd	20
Rhino Hammers	10
Senwes (John Deere)	29
Sintech	13
The Seat Connection	25
Turbofix	5,BC
TVH PARTS SA	15

STARTERS

CTC Plant Company	IFC
Denver Truck Spares	8,
Gears for Africa	6

TRANSPORT/TRUCKS/

TRAILERS

ATSE- services & Equipment	27
CTC Plant Company	IFC,38
Denver Truck Spares	8
E & A Spares	26
H.V.R Turbos	29
Perma Seating	18,19
Synergy WWL	29

TURBOS

CTC Plant Company	IFC
Denver Truck Spares-	8,
Midplant Services	24
Precision Diesel	11
Turbofix	5,BC

TYRES

ATSE- services & Equipment	27
Bell Equipment	4
Denver Truck Spares	8
TVH PARTS SA	15



INDEX

PLACING BUYERS AND SELLERS TOGETHER

TURBOFIX

"We are the leaders in the turbocharging field"

Facts for Customers

We know that there are customers that believe you can't repair a Turbocharger due to the bad experience with poor workmanship in Turbocharger Companies.

Quality Turbocharger repairs are infinitely possible, as long as the correct equipment & knowledge is used. Cheaper Turbochargers are not always the same quality, due to inferior quality & low cost parts. (Price vs. Quality)

We strive to supply the best Quality.



"There is no substitute for quality & service"