



**LEADING THE WAY IN  
HAZARDOUS AREA STATIC CONTROL**

[www.newson-gale.co.uk](http://www.newson-gale.co.uk)

# MITIGATE ELECTROSTATIC IGNITION RISKS IN EXPLOSIVE ATMOSPHERES WITH STATIC GROUNDING AND BONDING SOLUTIONS



<b>Company</b>	<b>5</b>
Total Quality Management	6
Our Connection To You	8
Design, Manufacture & Distribution	12
Solution Specification Criteria	14
Levels of Risk Mitigation	16
<b>Earth-Rite® Range</b>	<b>18</b>
Earth-Rite® II RTR	20
Earth-Rite® II MGV	28
Earth-Rite® II PLUS	36
Earth-Rite® MULTIPOINT II	44
Earth-Rite® DGS	52
Earth-Rite® II FIBC	58
<b>Bond-Rite® Range</b>	<b>66</b>
Bond-Rite® CLAMP	68
Bond-Rite® EZ	74
Bond-Rite® REMOTE	80
<b>Cen-Stat™</b>	<b>88</b>
Cen-Stat™ Clamps & Cables	90
Cen-Stat™ Cable Reels	96
Personnel Grounding Strap	104
<b>Earth-Rite® &amp; Bond-Rite® Methods of Connection</b>	<b>108</b>
Large Size Heavy-Duty Static Grounding Clamp	112
Medium Size Heavy-Duty Static Grounding Clamp	114
Magnetic Static Grounding Clamp	116
Surface Mount Grounding Connector	118
<b>Testing Equipment</b>	<b>124</b>
OhmGuard®	126
Sole-Mate™ II	132
<b>Technical Articles</b>	<b>136</b>
Static Electricity and its Role as a Potential Ignition Source in Ex Areas	138
Criteria for Selecting Static Grounding Equipment	144
Controlling the Risk of Electrostatic Ignitions in Ex/HAZLOC Operations	148
Specification of Hazardous Area Certified Equipment	156



# LEADING THE WAY IN HAZARDOUS AREA STATIC CONTROL

For over four decades, Newson Gale has been a leader in providing static grounding and bonding solutions for companies running operations in Ex Explosive Atmospheres.



**Newson Gale**  
HOERBIGER Safety Solutions



Newson Gale’s mission is to help customers bridge the gap between HAZOP assessments and the implementation of static control solutions that meet both safety and operational requirements.

Newson Gale offers a wide range of solutions, from advanced patented systems that verify connections to a true earth ground, to active self-monitoring ground connections with the option of interlocks, as well as simpler alternatives like passive clamps, cables, and reels. This flexibility enables you to select solutions that best match your specific installation, process equipment, and Ex area zoning requirements.

We enhance operational efficiency by supporting the standardisation of static grounding and bonding practices and simplifying the installation and on-going maintenance of our solutions.

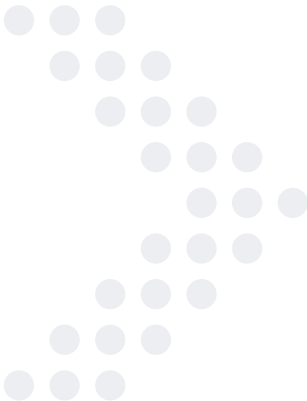

Our range of Ex-certified products supports your compliance objectives across global site locations.



# TOTAL QUALITY MANAGEMENT

Our approach to **Total Quality Management** means every product is tested and verified to meet the strictest industry standards.



Our **Quality Management System** is rigorously certified to ISO 9001 and ISO/IEC 80079-34\* standards, ensuring we meet the highest benchmarks in the manufacture of Ex-certified products.

This commitment to quality is reflected not only in our products but also in our manufacturing processes, which are tightly controlled from design through to manufacture.

\* “Explosive atmospheres – Part 34: Application of quality systems for Ex Product manufacture”.

**7** YEAR  
ELECTRONIC COMPONENTS  
**WARRANTY**

We offer our customers a 7-Year Warranty on all electronic components, demonstrating our confidence in the durability and reliability of our solutions.

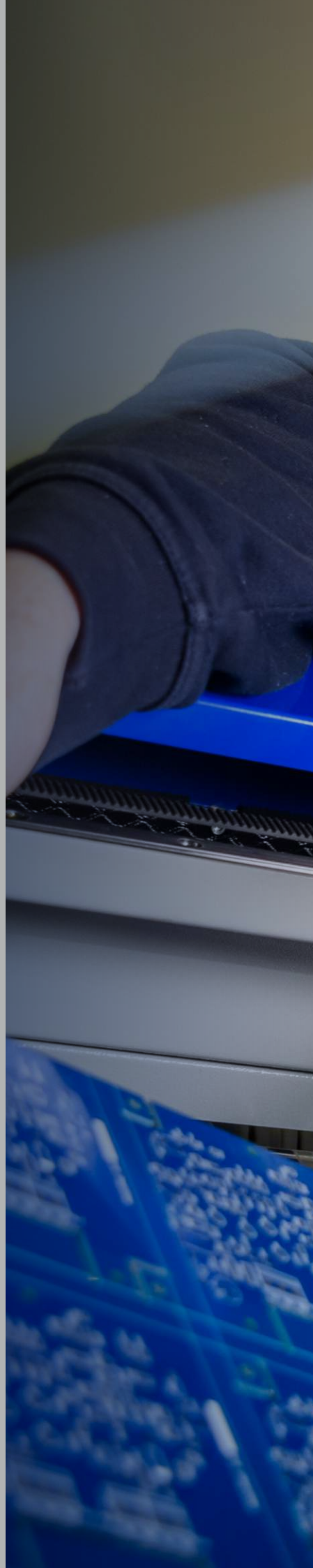
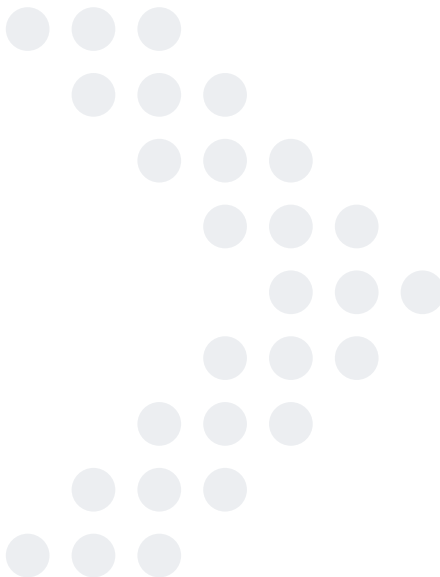



**QUALITY IS AT THE HEART  
OF EVERYTHING WE DO**

Start - already in the  
@ Save on USB  
Newson G5 - also  
Learn from USB - also

PERSONAL FEEDER 1

# OUR CONNECTION TO YOU

By choosing **Newsom Gale**, you're not only getting industry-leading products. You also benefit from the ongoing support of our dedicated team, committed to helping you achieve safer, more efficient operations across your entire network.



OPERATING  
PARAMETERS



TECHNICAL  
SUPPORT



GLOBAL  
DISTRIBUTION

Our **Regional Managers** are committed to delivering personalised assistance by quickly responding to your needs, taking the time to understand your operations, and collaborating with you to identify grounding and bonding solutions that align with your requirements.

This hands-on approach helps us recommend solutions that address your unique **safety, installation, and operational challenges**.





**BY WORKING WITH OUR REGIONAL MANAGERS, YOU GAIN ACCESS TO VALUABLE INDUSTRY INSIGHTS TO HELP IMPLEMENT LONG-TERM SAFETY SOLUTIONS**

Their guidance supports you with selecting the right solutions to improve safety, optimise operations, and mitigate static control risks.

# OUR CONNECTION TO YOU

Together, we will work with you to navigate the complexities of static control, supporting your efforts to make your Ex operations safer, more efficient, and future-ready.



Earth-Rite® MULTIPOINT II  
Multi-channel Static Bonding System

Monitoring Unit

Earth-Rite® MULTIPOINT  
Multi-channel Static Grounding System

Online demonstrations, videos and one-to-one sessions are available.



7 year warranty

Remote indicator station

Heavy-duty grounding clamp

Clear GO/NO-GO indication

Active monitoring

Monitoring unit

Ground monitoring circuits

PSU

Interlocks

Detailed product information and customer support are available.

At **Newson Gale**, we understand that your time is valuable, especially when it comes to mitigating the risks associated with the processing and handling of materials in hazardous areas.

With over four decades of experience in static grounding and bonding solutions for Explosive Atmospheres, we are here to help you bridge the gap between your **HAZOP** assessment, which identifies potential static ignition risks, and the implementation of solutions that best match your safety and operational needs.

We know that when urgent issues arise, there's often pressure to act quickly. But in our experience, rushing decisions can lead to avoidable complications.

**By taking the time to understand your unique challenges and providing you with a broad range of options, Newson Gale helps you gain control of the situation more effectively.**

# Live Product Demo



INNOVATION IN  
STATIC CONTROL



TECHNICAL  
SUPPORT



**Earth-Rite® II PLUS**  
Static Grounding System



Scan QR Code  
To book a **Live Demo**



Our **Regional Managers** are committed to responding promptly to your needs. They engage in **detailed discussions** to better understand your operations and collaborate with you to identify the **right solutions** for enhancing your grounding and bonding protocols.

# DESIGN, MANUFACTURE & DISTRIBUTION

Rather than sourcing Ex-certified components from third parties, Newson Gale designs and manufactures its own electronic circuits. This approach allows for greater control over critical design features, manufacturing processes, and supply chain management. As a result, we are delighted to offer our customers a 7-year warranty against manufacturer's defects on our electronic components.

Our clamps and cables are manufactured to our precise design specifications and sourced from partner locations within a 2 hour drive of our production facility. This localised sourcing allows us to maintain a high level of control over quality, manufacturing processes, and delivery timelines. All products are assembled, labelled, and tested at our manufacturing facility in Nottingham, UK to ensure they meet our strict quality standards and comply with industry certifications.

By choosing Newson Gale, you can standardise your static control solutions across your global network, with products designed to meet Ex-certification requirements and support compliance with local regulations, including ATEX, IECEx, and NEC, where applicable.

Our Quality Management System is rigorously certified to **ISO 9001** and **ISO/IEC 80079-34\*** standards, ensuring we meet the highest benchmarks in the manufacture of Ex-certified products.

\* "Explosive atmospheres – Part 34: Application of quality systems for Ex product manufacture".





**A WORLDWIDE SERVICE, SHIPPING  
CERTIFIED STATIC CONTROL  
SOLUTIONS GLOBALLY – EITHER  
DIRECTLY FROM OUR FACTORY  
OR THROUGH OUR NETWORK OF  
AUTHORISED CHANNEL PARTNERS**

# SOLUTION SPECIFICATION CRITERIA

1 

## **SPECIFY SOLUTIONS THAT CAN SUPPORT COMPLIANCE**

Our goal is to provide you with products that support the standardisation of grounding and bonding practices in Ex atmospheres. While certification standards exist for electrical and mechanical equipment used in hazardous areas, formal product standards addressing specific performance criteria for static control solutions are limited. To help you demonstrate alignment with industry best practices, our products incorporate technical recommendations from IEC TS 60079-32-1\*, NFPA 77\*, and other relevant industry-specific guidelines. We are committed to providing solutions that align with industry recommendations and best practices, despite the absence of specific product performance standards in this field.

2 

## **TAILORED TO PROCESS EQUIPMENT SUPPORTING OPERATOR SOPs**

We understand from experience that specifying static control solutions is not a "one-size-fits-all" task for our customers. While we offer specific products for specific types of process equipment, we also provide the flexibility to implement a range of hardware solutions across your facility. This approach helps manage different levels of risk more effectively, accommodates your facility's zoning requirements, considers installation preferences, and meets operator interface needs. Our regional managers are available to help establish the best solutions for your specific situation.

3 

## **LEVEL OF CONTROL DESIRED**

Based on many years of customer feedback, it's clear that operators prefer not to be expected to take, or interpret, electrical resistance readings. To simplify this process, flashing LEDs provide a clear method of indicating an active self-monitoring ground connection, improving the safety of equipment exposed to risks from static charge accumulation. For greater control, options like output contacts that can interlock with process equipment are available, preventing operation if a reliable ground connection isn't established initially. Additionally, you can choose from less advanced options like passive clamps, cables, and reels to suit your specific needs.

\* **IEC TS 60079-32-1** "Explosive atmospheres, Electrostatic hazards, guidance"  
**NFPA 77** "Recommended Practice on Static Electricity".

4 **Ex PRODUCT  
CERTIFICATES**

By selecting Newson Gale products, you benefit from a wide range of national and international certifications that enable you to standardise your static control solutions across your entire network. This consistency not only supports compliance but also simplifies operations across your regional and global locations.

5 **Ex AREA  
CLASSIFICATION**

Areas classified into zones helps determine the right equipment for your hazardous area. Familiarity with the Explosive Atmospheres EN/IEC 60079 series of standards supports compliance and enhances safety. If you require clarification regarding the specification of Ex-certified equipment, our dedicated Ex-engineering team is available to assist with any Newson Gale product certification and installation questions you may have.

6 **DELIVERY LEAD TIMES  
AND DISTRIBUTION**

We understand that you want your product delivered as quickly as possible, our competitive lead times support you with gaining control over your installation timeline. We offer worldwide shipping, subject to applicable regional restrictions and regulatory requirements.



**TO FIND OUT MORE, PLEASE READ THE  
TECHNICAL ARTICLE ON PAGE 144**

# LEVELS OF RISK MITIGATION

Providing operators with a clear, easy-to-follow **Standard Operating Procedure (SOP)** for equipment that may accumulate hazardous electrostatic charge gives them direct control over safety. A basic SOP like “**Clamp On First, Clamp Off Last**” makes grounding the first and last step in every process, providing a simple, reliable protocol for operators to follow.

## Comprehensive Safety Through Multiple Control Levels

By combining clear **SOPs** with easy-to-interpret visual indicators, active ground circuit monitoring, system interlocks, and **Ex-certification** compliance, operators are equipped to oversee static safety and mitigate ignition risks effectively.

The following features support operators with enhancing the layers of protection over the process operation.

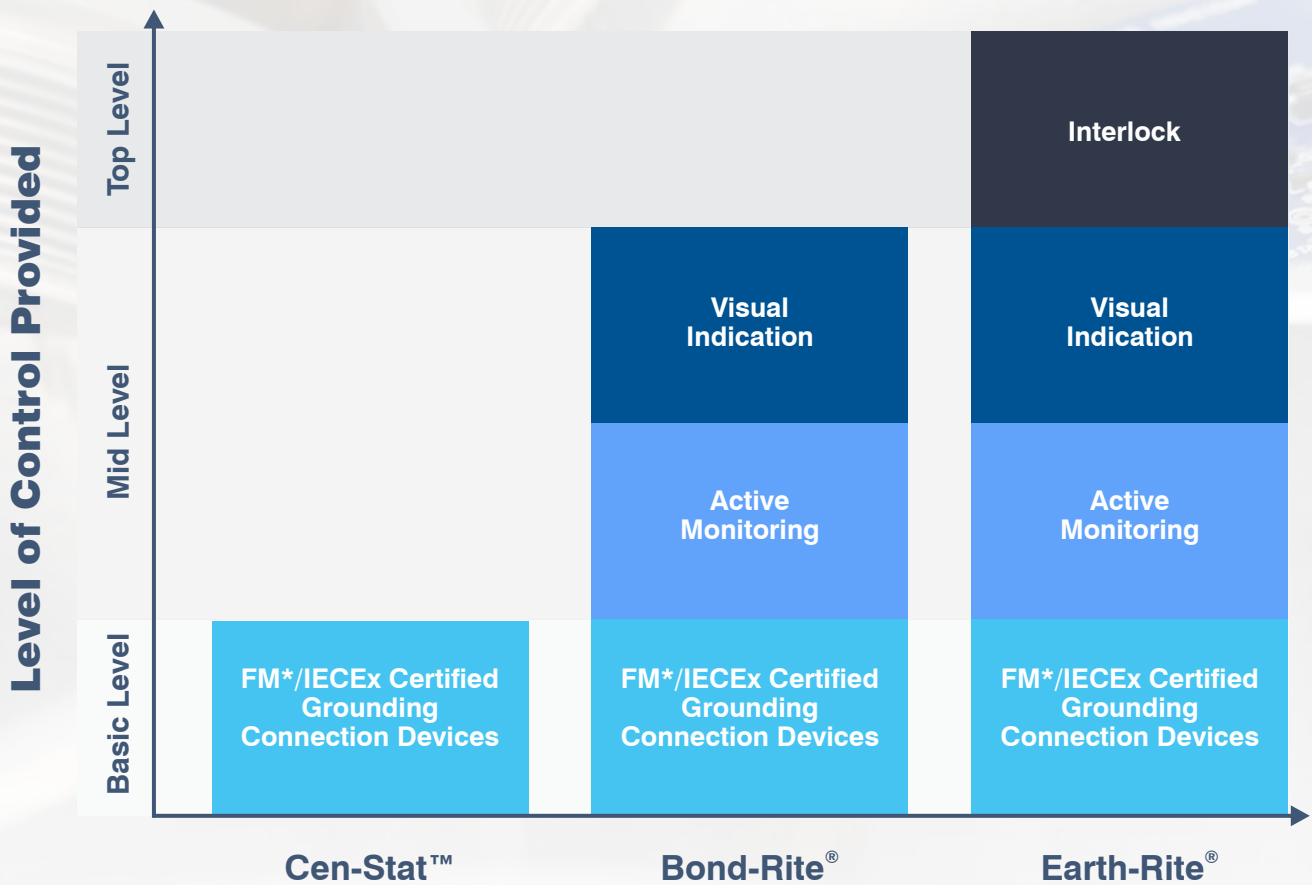

\* FM approval depending on product selected.

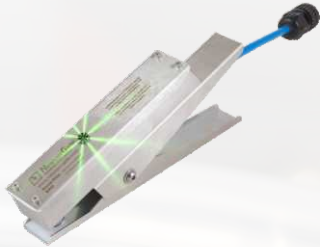

## QUICK, CONFIDENT GROUNDING VERIFICATION WITH VISUAL INDICATORS

Visual indicators, like a high intensity flashing green LED, allow operators to quickly check if grounding is in place, offering a clear signal when a reliable earth connection is made. This "GO/NO-GO" principle removes any guesswork, reducing the need for taking and interpreting complex resistance readings or multiple indicator settings. Newson Gale's visual solutions, including the red/green "traffic light" method, or a single green flashing LED, help operators take confident action.



## ACTIVE GROUND MONITORING CIRCUITS AT 10 OHMS

Static charges on equipment can generate high voltages, creating sparks that may be hazardous. To prevent this, it's crucial to maintain grounding resistance within recommended limits. Published industry best practice, such as those from the IEC\* and NFPA\*, recommend no more than 10 ohms between equipment and a verified earth point. Actively monitoring the ground circuit to maintain resistance between 0 to 10 ohms, enhances the performance of the SOP and aligns the grounding operation with recommended practice.

\* **IEC TS 60079-32-1** "Explosive atmospheres, Electrostatic hazards, guidance"  
**NFPA 77** "Recommended Practice on Static Electricity".



## ENHANCED CONTROL THROUGH INTERLOCKS COMBINED WITH ACTIVE GROUND MONITORING CIRCUITS

When grounding systems are interlocked with process control circuits, operators gain an extra layer of control. Linking grounding systems with PLCs or emergency shutdown systems prevents processes from starting until grounding is verified, reducing static risk. This added control is particularly beneficial in large operations with containers, Ex IBCs, road tankers, or railcars, where maintaining safety at scale is critical.

# Earth-Rite® Range

**Newson Gale**  
HOERBIGER Safety Solutions

## INTERLOCK SYSTEMS WITH ACTIVE MONITORING



**Earth-Rite® II RTR**

Grounding for road tankers at loading gantries.



20



**Earth-Rite® II MGV**

Vacuum tanker/road tanker mounted ground verification system.



28



**Earth-Rite® II PLUS**

A flexible grounding solution for a wide range of metal objects at risk of static charge accumulation.



36



**Earth-Rite® MULTIPOINT II**

A grounding solution that can ground and monitor up to eight individual pieces of equipment.



44



**Earth-Rite® DGS**

A dual grounding solution that can ground and monitor two individual pieces of equipment.

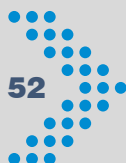

52



**Earth-Rite® II FIBC**

A grounding solution designed specifically for grounding and monitoring Type C FIBC bags.



58

# Earth-Rite® II RTR™

In explosive environments, safeguarding road tanker loading and unloading operations is critical.

The **Earth-Rite® II RTR™** from Newson Gale provides a robust and reliable solution for grounding road tankers in hazardous Ex areas.



## KEY FEATURES

### Clear Visual Indicators

- One solid red and three high intensity green flashing LEDs for easy “GO/NO-GO” indication to operators.
- **Benefit:** Simplifies operator decision-making with clear, easily recognisable signals that indicate that grounding is in place.

### No Calibration Required

- The system does not require calibration at installation or throughout its lifecycle.
- **Benefit:** Saves valuable time and eliminates the risk of operational delays, making tanker loading/unloading more efficient.

### Heavy-Duty Stainless Steel Clamp

- Uses sharpened tungsten carbide teeth and a strong torsion spring to establish and maintain a positive connection.
- **Benefit:** Provides a secure and reliable connection to the road tanker throughout the loading/unloading operation.

### Maintenance Tester

- Can be supplied with a tester for maintenance personnel to validate operating parameters as part of routine maintenance.
- **Benefit:** Provides a tool for proactive maintenance, ensuring the system is always functioning optimally and reducing downtime.

### Wide Range of Gas and Dust Groups

- Can be installed in all gas groups (IIA, IIB, IIC) and all dust groups (IIIA, IIIB, IIIC).
- **Benefit:** Versatile installation for a wide range of hazardous environments, offering increased flexibility for various applications.

### Compliance with No Insulating Materials

- The grounding clamp contains no insulating materials (rubber/plastic) that exceed the volume or surface area limits for Ex areas (IEC TS 60079-32-1).
- **Benefit:** Meets strict Ex areas safety standards without the need for additional insulating materials, ensuring compliance and safety.

# PATENTED TRI-MODE TECHNOLOGY

1

## TANKER CAPACITANCE CHECK

Utilises the capacitance of the road tanker to promote a "Clamp On First, Clamp Off Last" protocol.

Ensures safe grounding protocol by confirming a secure connection before and after material transfer, reducing the risk of electrostatic discharge.



2

## CONNECTION VERIFICATION TO EARTH

Determines if the designated grounding point at the loading gantry is properly connected to the general mass of the earth.

Provides assurance that the loading gantry is grounded correctly, ensuring safety before starting the transfer.

3

## ACTIVE RESISTANCE MONITORING

Monitors the resistance of the circuit between the road tanker and the grounding point, ensuring it is  $\leq 10$  ohms.

Continuously verifies the quality of the connection during the transfer process, minimising grounding issues that could lead to hazards.

### No Need for Compound-Filled Cable Glands

- When installed in accordance with EN IEC 60079-14, compound-filled cable glands may not be required.
- **Benefit:** Simplifies installation and reduces costs by eliminating the need for specialised cable glands.

### Flexible Cable Options

- Cables can be specified in either spiral format, or straight if used as part of the dual core retractable cable reel.
- **Benefit:** Reduces clutter and improves operational efficiency.

### International and National Certifications

- Comes with certifications for compliance with international and national safety standards.
- **Benefit:** Ensures global compliance, offering confidence that the system meets recognised safety standards in various regions.

### Reliable Volt-Free/Dry Contacts

- For increased capability, additional Intrinsically Safe switching solutions available.
- **Benefit:** Enhances control over process equipment, providing options that can be tailored to specific safety and operational needs.



# Earth-Rite® II RTR™

Newsom Gale's dedicated road tanker static grounding system with system interlocks and visual indication.



## 1

### Clamp On First, Clamp Off Last Protocol

"Clamp On First, Clamp Off Last" (CoF/CoL) protocol and patented Tri-Mode Technology mitigates against electrostatic discharge during product transfer.

## 2

### Active Monitoring

Actively monitors the resistance of the circuit between the connection to the road tanker and the loading gantry's designated grounding point to 10 ohms or less.

**DOES NOT** require calibration at installation or throughout its lifecycle.

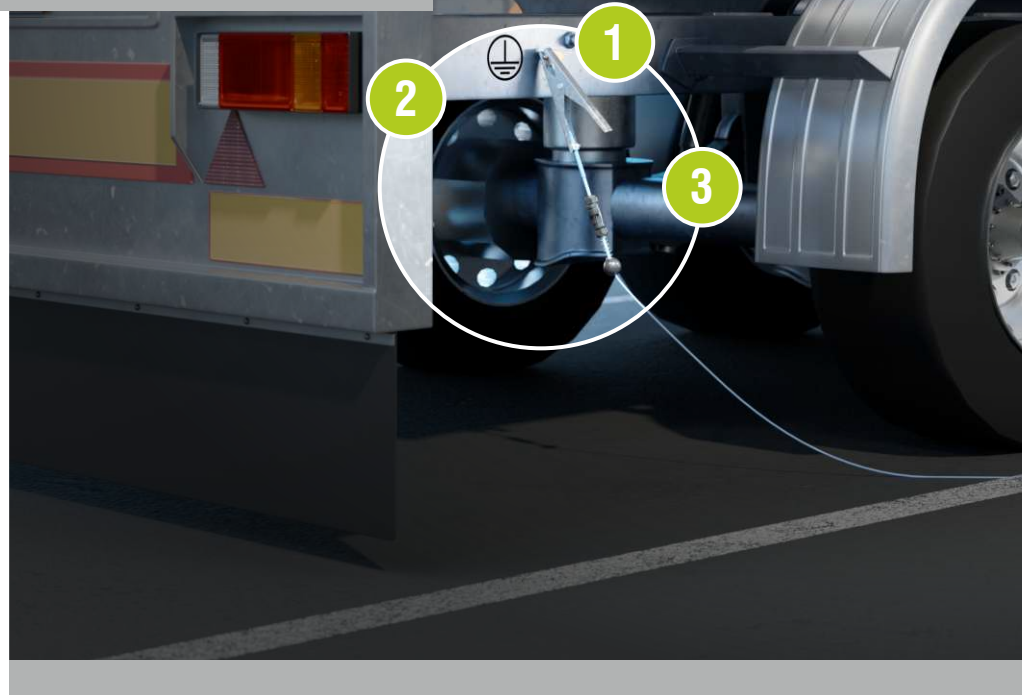

## 3

### Heavy-Duty Grounding Clamp

Utilises a heavy-duty stainless steel clamp, that combines sharp tungsten carbide teeth with a strong torsion spring to establish, and maintain, a positive connection to the road tanker for the duration of the loading/unloading operation.

Grounding clamps **DO NOT** contain any insulating materials (rubber/plastic) that exceed the volume or surface area for Ex areas as specified in IEC TS 60079-32-1 (does not require rubber handle).

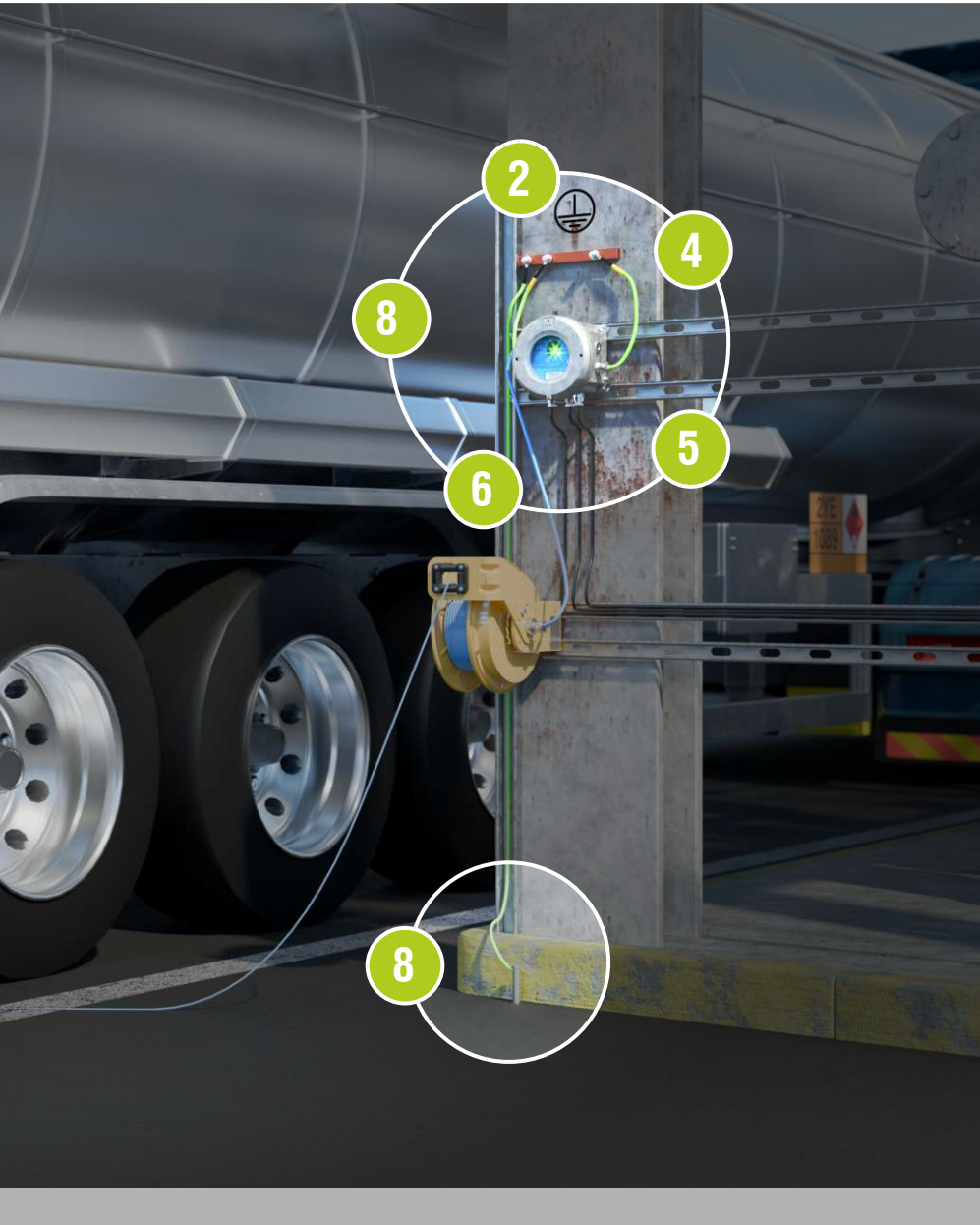

# 8

## General Mass Of Earth Connection

Patented Tri-Mode Technology determines if the designated grounding point at the loading gantry has a connection to the general mass of the earth capable of dissipating electrostatic charge.

# 7

## Interlocks

Standard volt-free contacts and optional intrinsically safe contacts for controlling process equipment (e.g., pumps).

# 6

## Clear "GO/NO-GO" Indication

One solid red and three green high intensity flashing LEDs provide easy to understand "GO" or "NO-GO" indication to operators. Positive ground connection is indicated via one solid red and three green high intensity flashing LEDs providing operators with a clear "GO/NO-GO" indication which can also aid operators with colour blindness.

# 4

## Calibration Not Required

Unlike many grounding systems that claim to detect the capacitance of the road tanker, the Earth-Rite® RTR grounding system stands out by eliminating the need for calibration during installation or throughout its service life. This saves labour time and cost while reducing the risk of delays in truck loading operations.

# 5

## Installation Flexibility

Can be installed in all gas groups (IIA, IIB and IIC) and all dust groups (IIIA, IIIB and IIIC).



Scan QR Code to make an enquiry

## Earth-Rite® II RTR™ Ex d Technical Specification

Ex d (Zone 1 Gas / Vapour Atmosphere - Zone 21 & 22 Dust Atmospheres)

### Power Supply & Monitoring-Unit

Power Supply	115 V or 230 V AC, 50-60 Hz 12 V or 24 V DC
Power Rating	10 watt
Ambient Temperature Range	-40°C to +55°C
Ingress Protection	IP66
Weight	4.5 kgs (9.9 lbs) net
Construction	Copper-free cast aluminium
Monitoring Circuit	Intrinsically safe "ia"
Monitoring Loop Resistance	Nominally $\leq 10 \Omega$
Output Relay Contact Rating	2 off volt-free/dry change-over contacts 250 V AC, 5 A, 500 VA max resistive 30 V DC, 2 A, 60 W max resistive
Cable Entries	7 x M20 (2 x plugged)

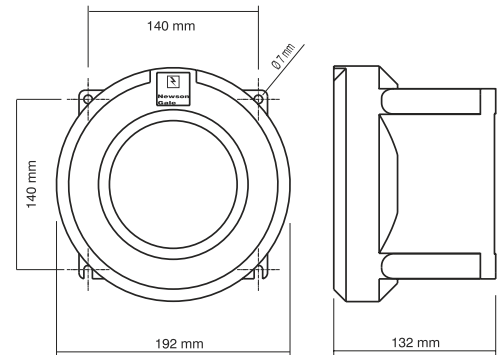

### Junction Box/Stowage Point

Enclosure Material	Static dissipative carbon loaded GRP
Terminals	2 x 2.5 mm <sup>2</sup> conductor capacity
Stowage Device	Insulated universal stowage pin
Cable Entries	1 x 20 mm
Clamp Cable Connection	Quick Connect

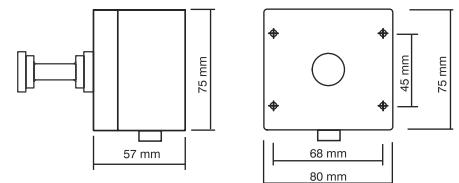

Simple Apparatus  
GRP junction box with nylon grounding clamp stowage pin

### Grounding Clamp

Clamp Design	Dual core with tungsten carbide teeth
Body	Stainless steel (SS grade: 304)
ATEX / FM / IECEx / UKEX Certification:	ATEX II 1 GD T6 (Assessed to EN 13463-1 : 2009) Sira 02ATEX9381 ATEX Notified Body: SIRA FM Certificate of Compliance number: 3046346
UKCA Ex II 1 G II 1 D Ex h IIC T6 Ga Ex h IIIC T85°C Da Ta = -40°C to +60°C ExVeritas 21UKEX0842 UKCA Ex Approved Body: ExVeritas	IECEX Ex h IIC T6 Ga Ex h IIIC T85°C Da Ta = -40°C to +60°C IECEX EXV 20.0033 IECEX Certified Body: ExVeritas

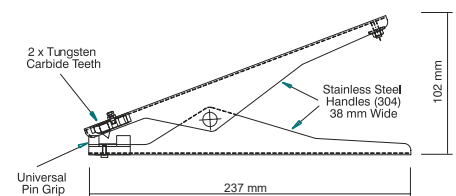

Static Grounding Clamp



Dual core stainless steel grounding clamp fitted with one pair of tungsten carbide tips

### Spiral Cable

Cable	Dual core Cen-Stat blue spiral cable with Hytrel coating which has UV and static dissipative additives
Conductors	2 x 1.00 mm <sup>2</sup> copper
Length	3 m (10 ft), 5 m (16 ft), 10 m (32 ft) or 15 m (50 ft)

## Earth-Rite® II RTR™ Ex d Hazardous Area Certification

### Europe/International

IECEX	Ex db [ia Ga] IIC T6 Gb Ex tb [ia Da] IIIC T80°C Db Ta = -40°C to +55°C IECEX EXV 19.0052 IECEX Certifying Body: ExVeritas
ATEX	 II 2(1)G II 2(1)D Ex db [ia Ga] IIC T6 Gb Ex tb [ia Da] IIIC T80°C Db Ta = -40°C to +55°C ExVeritas 19ATEX0537 ATEX Notified Body: ExVeritas
UKCA Ex	 II 2(1)G II 2(1)D Ex db [ia Ga] IIC T6 Gb Ex tb [ia Da] IIIC T80°C Db Ta = -40°C to +55°C ExVeritas 21UKEX0832 UKCA Ex Approved Body: ExVeritas
CCC	Ex db [ia Ga] IIC T6 Gb Ex tb [ia Da] IIIC T80°C Db Ta = -40°C to +55°C 2021312304001040 Approved Body: CNEC
KCS (Gas)	Ex d [ia Ga] IIC T6 Gb(Ga) Ta = -40°C to +55°C 22-AV4BO-0330X Approved Body: KOSHA
KCS (Dust)	Ex tb IIIC T80°C IP66 Db Ta = -40°C to +55°C 22-AV4BO-0331X Approved Body: KOSHA

### North America Version Available

NEC 500 / CEC (Class & Division)	Associated Equipment [Ex ia] for use in Class I, Div. 1, Groups A, B, C, D Class II, Div. 1, Groups E, F, G Class III, Div. 1 Providing intrinsically safe circuits for Class I, Div. 1, Groups A, B, C, D Class II, Div. 1, Groups E, F, G Class III, Div. 1 Temperature Code T6 Ta = -40°F to +122°F (-40°C to +50°C) OSHA recognised NRTL: CSA.
NEC 505 & 506 (Class & Zoning)	Class I, Zone 1 [0] AEx d[ia] IIC T6 Gb(Ga) Class II, Zone 21 [20] AEx tD [iaD] 21 T80°C
CEC Section 18 (Class & Zoning)	Class I, Zone 1 [0] Ex d[ia] IIC T6 Gb(Ga) DIP A21, IP66, T80°C

### Additional Certification

Safety Integrity Level	SIL 2 (in accordance with IEC/EN 61508)
EMC Tested	to EN 61000-6-3, EN 61000-6-2 FCC - Part 15 (Class B)

## Earth-Rite® II RTR™ GRP Technical Specification

GRP (Zone 2 Gas / Vapour Atmosphere - Zone 21 & 22 Dust Atmospheres)

### Power Supply & Monitoring-Unit

Power Supply	115 V or 230 V AC, 50-60 Hz 12 V or 24 V DC
Power Rating	10 watt
Ambient Temperature Range	-40°C to +55°C
Ingress Protection	IP66
Weight	2 kgs (4.4 lbs) net
Construction	Static dissipative carbon loaded GRP
Monitoring Circuit	Intrinsically safe "ia"
Monitoring Loop Resistance	Nominally $\leq 10 \Omega$
Output Relay Contact Rating	2 off volt-free/dry change-over contacts 250 V AC, 5 A, 500 VA max resistive 30 V DC, 2 A, 60 W max resistive
Cable Entries	7 x M20 (2 x plugged)

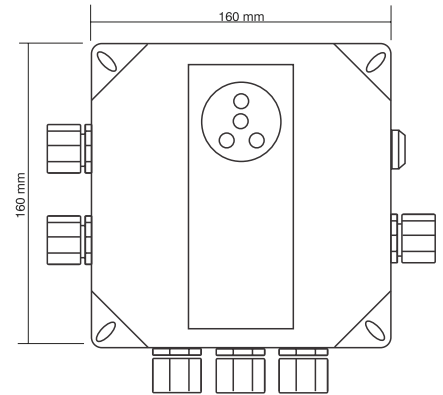

### Junction Box/Stowage Point

Enclosure Material	Static dissipative carbon loaded GRP
Terminals	2 x 2.5 mm <sup>2</sup> conductor capacity
Stowage Device	Insulated universal stowage pin
Cable Entries	1 x 20 mm (4 x plugged)
Clamp Cable Connection	Quick Connect

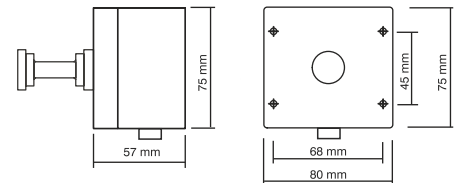

Simple Apparatus  
GRP junction box with nylon grounding clamp stowage pin

### Grounding Clamp

Clamp Design	Dual core with tungsten carbide teeth
Body	Stainless steel (SS grade: 304)
ATEX / FM / IECEx / UKEX Certification:	ATEX II 1 GD T6 (Assessed to EN 13463-1 : 2009)
UKCA Ex	Ta = -40°C to +60°C Sira 02ATEX9381 ATEX Notified Body: SIRA FM Certificate of Compliance number: 3046346
UKCA Ex II 1 G	IECEX
UKCA Ex II 1 D	Ex h IIC T6 Ga
UKCA Ex Ex h IIC T6 Ga	Ex h IIC T85°C Da
UKCA Ex Ex h IIC T85°C Da	Ta = -40°C to +60°C
UKCA Ex ExVeritas 21UKEX0842	IECEX
UKCA Ex Approved Body: ExVeritas	Ex h IIC T6 Ga Ex h IIC T85°C Da Ta = -40°C to +60°C IECEX EXV 20.0033 IECEX Certified Body: ExVeritas

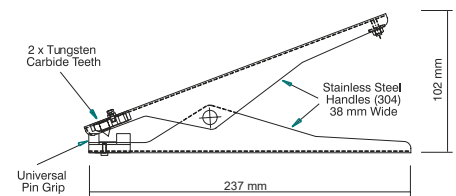

Static Grounding Clamp



Dual core stainless steel grounding clamp fitted with one pair of tungsten carbide tips

### Spiral Cable

Cable	Dual core Cen-Stat blue spiral cable with Hytrel coating which has UV and static dissipative additives
Conductors	2 x 1.00 mm <sup>2</sup> copper
Length	3 m (10 ft), 5 m (16 ft), 10 m (32 ft) or 15 m (50 ft)

## Earth-Rite® II RTR™ GRP Hazardous Area Certification

### Europe/International

IECEX	<p>Ex ec nC [ia Ga] IIC T4 Gc            Ex tb [ia Da] IIIC T70°C Db            Ta = -40°C to +55°C            IECEX EXV 19.0059X            IECEX Certifying Body: ExVeritas</p>
ATEX	<p> II 3(1)G            II 2(1)D            Ex ec nC [ia Ga] IIC T4 Gc            Ex tb [ia Da] IIIC T70°C Db            Ta = -40°C to +55°C            ExVeritas 19ATEX0545X            ATEX Notified Body: ExVeritas</p>
UKCA Ex	<p> II 3(1)G            II 2(1)D            Ex ec nC [ia Ga] IIC T4 Gc            Ex tb [ia Da] IIIC T70°C Db            Ta = -40°C to +55°C            ExVeritas 21UKEX0833X            UKCA Ex Approved Body: ExVeritas</p>
CCC	<p>Ex ec [ia Ga] nC IIC T4 Gc            Ex tb [ia Da] IIIC T70°C Db            Ta = -40°C to +55°C            2021312304001041            Approved Body: CNEC</p>
KCS (Gas)	<p>Ex ec nC [ia Ga] IIC T4 Gc(Ga)            Ta = -40°C to +55°C            22-AV4BO-0317X            Approved Body: KOSHA</p>
KCS (Dust)	<p>Ex tb IIIC T70°C Db            Ta = -40°C to +55°C            22-AV4BO-0318X            Approved Body: KOSHA</p>

### North America Version Available

<p>NEC 500 / CEC            (Class &amp; Division)</p>	<p>Associated Equipment [Ex ia] for use in            Class I, Div. 2, Groups A, B, C, D            Class II, Div. 2, Groups E, F, G            Class III, Div. 2            Providing Intrinsically Safe circuits for            Class I, Div. 1, Groups A, B, C, D            Class II, Div. 1, Groups E, F, G            Class III, Div. 1            Temperature Code T4            Ta = -13°F to +131°F (25°C to +55°C)            OSHA recognised NRTL: CSA</p>
<p>NEC 505 &amp; 506            (Class &amp; Zoning)</p>	<p>Class I, Zone 2, (Zone 0), AEx nA[ia] IIC T4            Class II, Zone 21, AEx tD[iaD] 21, T70°C</p>
<p>CEC Section 18            (Class &amp; Zoning)</p>	<p>Class I, Zone 2 (Zone 0) Ex nA[ia] IIC T4            DIP A21, IP66, T70°C</p>

### Additional Certification

Safety Integrity Level	SIL 2 (in accordance with IEC/EN 61508)
EMC Tested	To EN 61000-6-3, EN 61000-6-2 FCC - Part 15 (Class B)

# Earth-Rite® II MGV

The **Earth-Rite® II Mobile Ground Verification system (MGV)** is a unique, patented technology designed to provide automatic confirmation of a positive electrostatic ground connection for trucks collecting and transferring flammable/combustible products.

The **Earth-Rite® II MGV** from Newson Gale provides a robust and reliable solution for grounding vacuum trucks and bulk chemical road tankers in Ex Hazardous Areas.



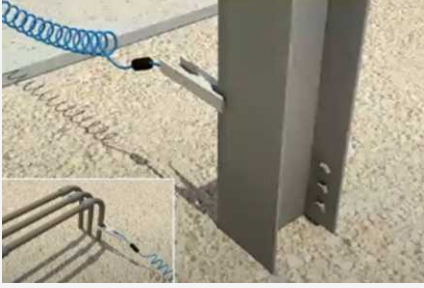
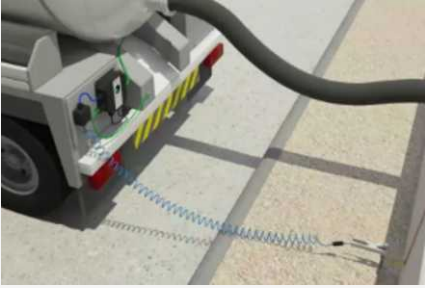

**1 PRIMARY**  
Permanent earth/rod network

Permanent installations like site designated earth rods and earthing networks that provide electrical fault and lightning protection.

**2 SECONDARY**  
Permanent 'man-made' structure

Permanent 'man-made' structures that have a good connection to the mass of the earth, like piping that runs underground and metal frames of buildings that run into the ground. Permission to use such structures should be agreed in advance with the site owner.

**3 TEMPORARY**  
Ground rods

Temporary ground rods that are typically used for emergency response scenarios where 'man-made' structures like those already described are not available to use.

# KEY FEATURES

## Patented Truck-Mounted Static Grounding System

- Provides a mobile solution for verifying the static electrical connection of trucks to earth during material transfer operations conducted in Ex atmospheres.
- **Benefit:** Offers flexibility for locations where static grounding systems are not permanently installed, reducing the need for multiple installations..

## Real-Time Active Monitoring

- Actively monitors the connection to the verified grounding point throughout the transfer operation.
- **Benefit:** Automatically detects a rise in the resistance above 10 ohms.

## Simple "GO/NO-GO" User Interface

- Simple high intensity, red and green flashing LED indicators for quick and easy interpretation of the trucks' electrostatic grounding status.
- **Benefit:** Simplifies operation, allowing drivers to quickly assess grounding status without complex tools or instructions.

## No Need for Additional Operating Interfaces

- No switches, dials, or resistance meter readings required for operation.
- **Benefit:** Reduces operational complexity, enabling faster deployment and reducing the likelihood of operator error.

## Intrinsically Safe (IS) Design

- Ground verification and active monitoring circuits utilise intrinsically safe "ia" signals to enhance safe operation in Ex atmospheres.
- **Benefit:** Supports compliance with safety regulations in Ex rated areas..

## Grounding Protocol Compliance

- Supports the "Clamp On First, Clamp Off Last" SOP for vacuum truck operators and road tanker drivers.
- **Benefit:** Enhances operational safety by ensuring grounding is maintained throughout the material transfer process, mitigating the risk of electrostatic discharge.

# Earth-Rite® II MGV

Newson Gale's dedicated truck mounted static grounding system designed to provide automatic confirmation of a positive electrostatic ground connection.

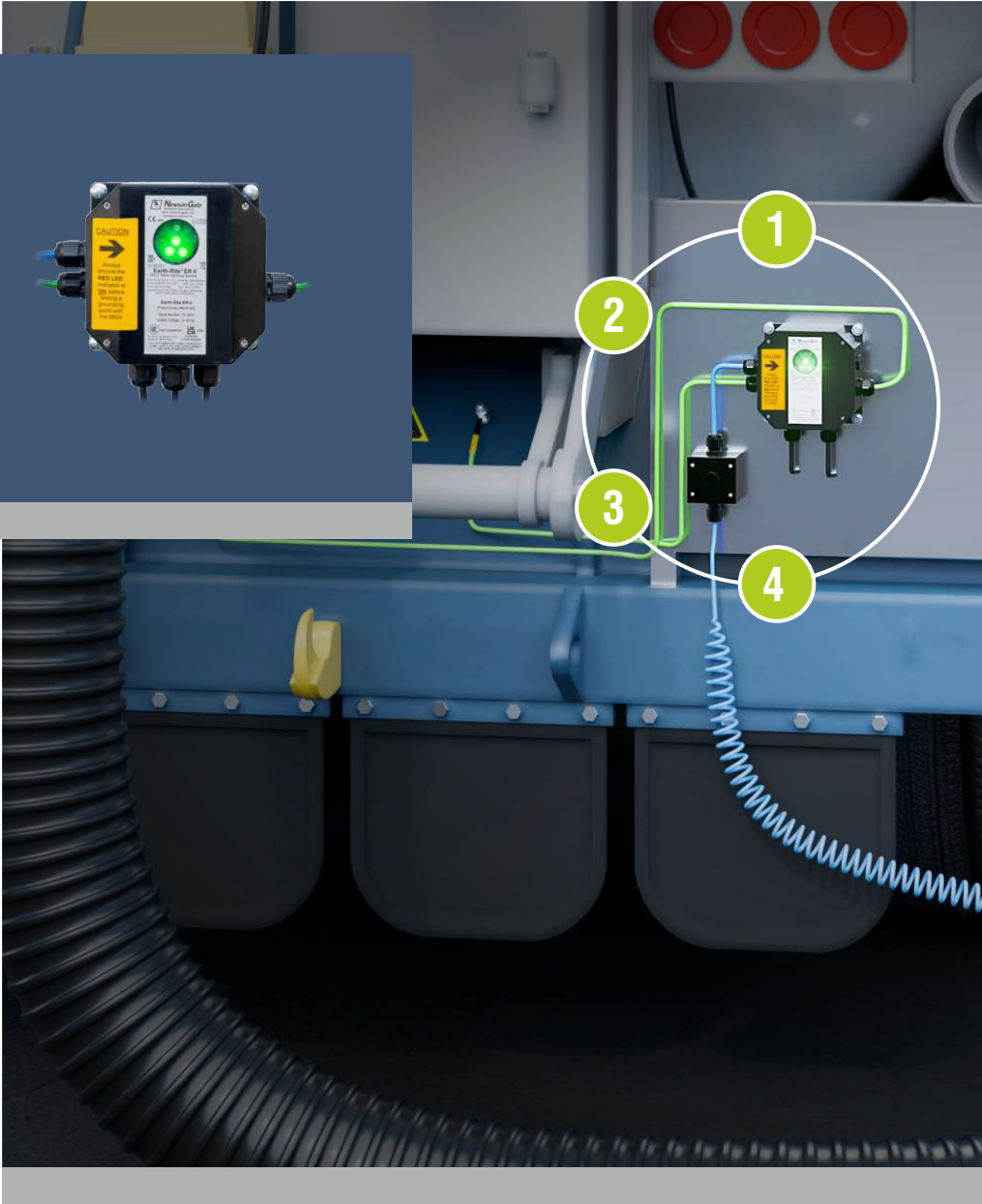

## 1

### Clear “GO/NO-GO” Indication

One solid red and three high intensity green flashing LEDs provide easy to understand “GO” or “NO-GO” indication to operators. Positive ground connection indicated via high intensity green flashing LEDs for their attention-grabbing effect. Flashing operation can aid operators with colour blindness.

## 2

### Installation Flexibility

Can be installed in all gas groups (IIA, IIB and IIC) and all dust groups (IIIA, IIIB and IIIC).

## 3

### Enclosure Options

Static dissipative GRP or cast aluminium Ex d enclosures are available.

## 4

### Clamp Stowage Point

Enables operators to stow the clamp and cable when the grounding system is not in use, using a dedicated stowage bracket.



IECEX



SIL 2

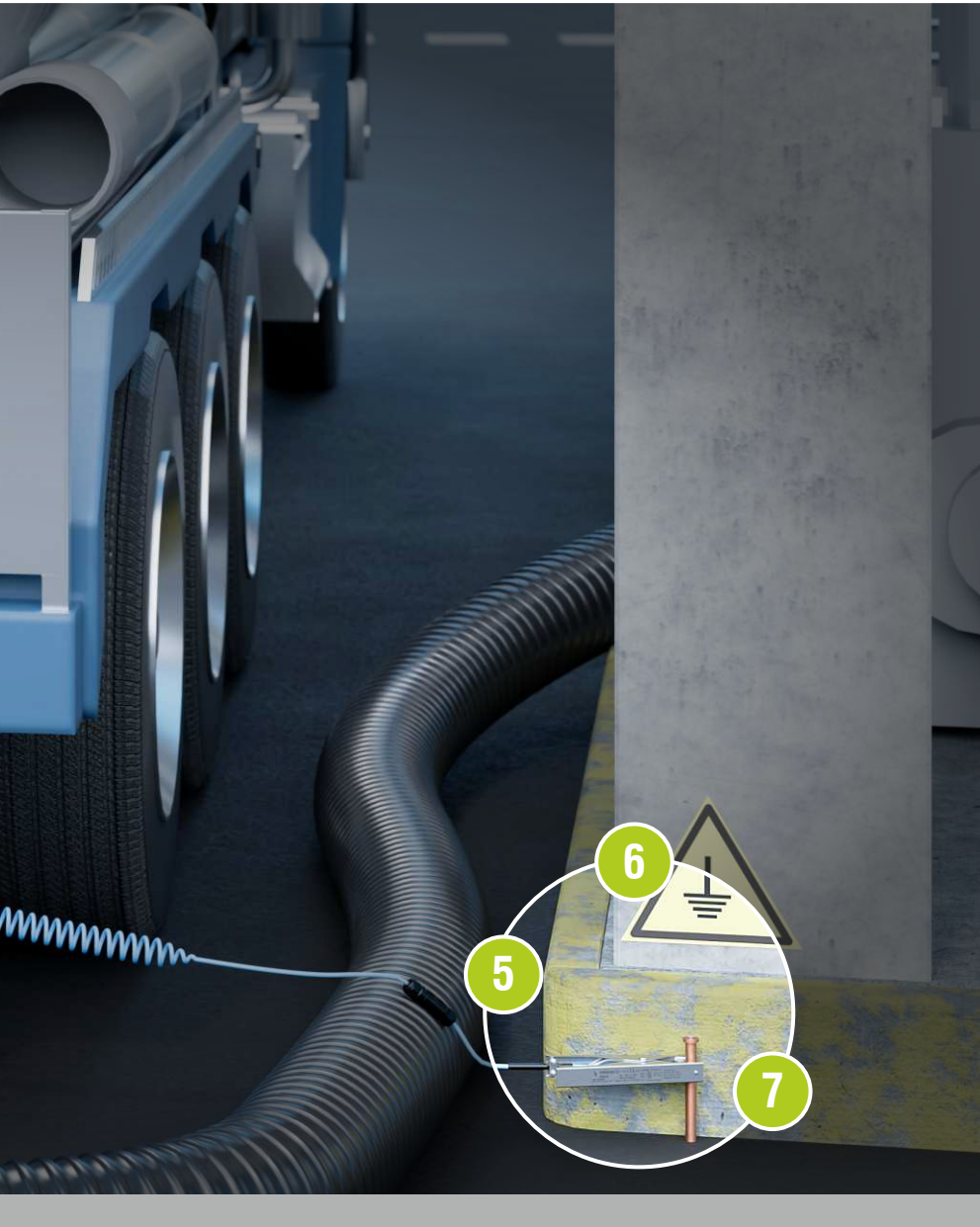

7

## Active Monitoring

Actively monitors the resistance of the circuit between the vacuum truck and the grounding point to 10 ohms or less.

**DOES NOT** require calibration at installation or throughout its lifecycle.

6

## General Mass of Earth Connection

Patented Tri-Mode Technology determines if the designated grounding point has a connection to the general mass of the earth capable of dissipating electrostatic charge.

5

## Heavy-Duty Grounding Clamp

Utilises a heavy-duty stainless steel clamp, that combines sharp tungsten carbide teeth with a strong torsion spring to establish, and maintain, a positive connection to the vacuum truck for the duration of the loading/unloading operation.

Grounding clamps **DO NOT** contain any insulating materials (rubber/plastic) that exceed the volume or surface area for Ex areas as specified in IEC TS 60079-32-1 (does not require rubber handle).



Scan QR Code  
to make an enquiry

## Earth-Rite® II MGV GRP Technical Specification

GRP (Zone 2 Gas / Vapour Installations - Zone 21 & 22 Dust Atmospheres)

### Power Supply & Monitoring Unit

Power Supply	12 V or 24 V DC
Power Rating	10 watt
Ambient Temperature Range	-40°C to +55°C
Ingress Protection	IP66
Weight	2 kgs (4.4 lbs) net
Construction	Static dissipative carbon loaded GRP
Monitoring Circuit	Intrinsically safe "ia"
Monitoring Loop Resistance	Nominally $\leq 10 \Omega$
Output Relay Contact Rating	2 off volt-free/dry change-over contacts 250 V AC, 5 A, 500 VA max resistive 30 V DC, 2 A, 60 W max resistive
Cable Entries	7 x M20 (2 x plugged)

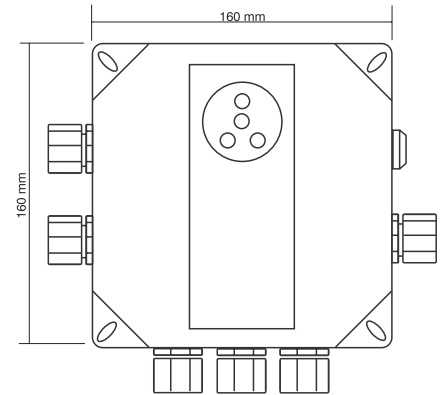

### Junction Box/Stowage Point

Enclosure Material	Static dissipative carbon loaded GRP
Terminals	2 x 2.5 mm <sup>2</sup> conductor capacity
Stowage Device	Insulated universal stowage pin
Cable Entries	1 x 20 mm (4 x plugged)
Clamp Cable Connection	Quick Connect

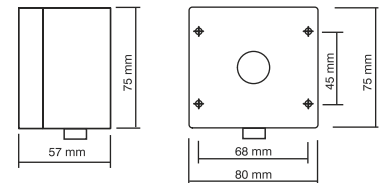

Simple Apparatus  
GRP junction box with nylon grounding clamp  
stowage pin and dust gap

### Grounding Clamp

Clamp Design	Dual core with tungsten carbide teeth
Body	Stainless steel (SS grade: 304)
ATEX / FM / IECEx / UKEX Certification:	ATEX II 1 GD T6 (Assessed to EN 13463-1 : 2009)
UKCA Ex II 1 G II 1 D Ex h IIC T6 Ga Ex h IIIC T85°C Da Ta = -40°C to +60°C ExVeritas 21UKEX0842 UKCA Ex Approved Body: ExVeritas	Sira 02ATEX9381 ATEX Notified Body: SIRA FM Certificate of Compliance number: 3046346
	IECEX Ex h IIC T6 Ga Ex h IIIC T85°C Da Ta = -40°C to +60°C IECEX EXV 20.0033 IECEX Certified Body: ExVeritas

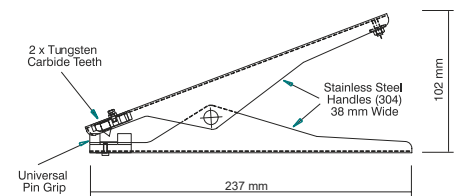



Static Grounding Clamp

Dual core stainless steel grounding clamp fitted with one pair of tungsten carbide tips

### Spiral Cable

Cable	Blue Cen-Stat Hytrel sheath (Static dissipative, chemical & abrasion resistant)
Conductors	2 x 1.00 mm <sup>2</sup> copper
Length	15 m (50 ft) extended (optional cable reel and additional lengths of Hytrel cable available - please enquire)

## Earth-Rite® II MGV GRP Hazardous Area Certification

Europe/International		North America Version Available	
IECEX	Ex ec nC [ia Ga] IIC T4 Gc Ex tb [ia Da] IIIC T70°C Db Ta = -40°C to +55°C IECEX EXV 19.0059X IECEX Certifying Body: ExVeritas	NEC 500 / CEC (Class & Division)	Associated Equipment [Ex ia] for use in Class I, Div. 2, Groups A, B, C, D Class II, Div. 2, Groups E, F, G Class III, Div. 2 Providing Intrinsically Safe circuits for Class I, Div. 1, Groups A, B, C, D Class II, Div. 1, Groups E, F, G Class III, Div. 1 Temperature Code T4 Ta = -13°F to +131°F (-25°C to +55°C) OSHA recognised NRTL: CSA
ATEX	 II 3(1)G II 2(1)D Ex ec nC [ia Ga] IIC T4 Gc Ex tb [ia Da] IIIC T70°C Db Ta = -40°C to +55°C ExVeritas 19ATEX0545X ATEX Notified Body: ExVeritas	NEC 505 & 506 (Class & Zoning)	Class I, Zone 2, (Zone 0), AEx nA[ia] IIC T4 Class II, Zone 21, AEx tD[iaD] 21, T70°C
UKCA Ex	 II 3(1)G II 2(1)D Ex ec nC [ia Ga] IIC T4 Gc Ex tb [ia Da] IIIC T70°C Db Ta = -40°C to +55°C ExVeritas 21UKEX0833X UKCA Ex Approved Body: ExVeritas	CEC Section 18 (Class & Zoning)	Class I, Zone 2 (Zone 0) Ex nA[ia] IIC T4 DIP A21, IP66, T70°C
CCC	Ex ec [ia Ga] nC IIC T4 Gc Ex tb [ia Da] IIIC T70°C Db Ta = -40°C to +55°C 2021312304001041 Approved Body: CNEX	<b>Additional Certification</b>	
KCS (Gas)	Ex ec nC [ia Ga] IIC T4 Gc(Ga) Ta = -40°C to +55°C 22-AV4BO-0321X Approved Body: KOSHA	Safety Integrity Level	SIL 2 (in accordance with IEC/EN 61508)
KCS (Dust)	Ex tb IIIC T70°C Db Ta = -40°C to +55°C 22-AV4BO-0322X Approved Body: KOSHA	EMC Tested	To EN 61000-6-3, EN 61000-6-2 FCC - Part 15 (Class B)

## Earth-Rite® II MGV Ex d Technical Specification

Ex d (Zone 1 Gas / Vapour / Dust Installations)

### Power Supply & Monitoring Unit

Power Supply	12 V or 24 V DC
Power Rating	10 watt
Ambient Temperature Range	-40°C to +55°C
Ingress Protection	IP66
Weight	4.5 kgs (9.9 lbs) net
Construction	Copper-free cast aluminium
Monitoring Circuit	Intrinsically safe “ia”
Monitoring Loop Resistance	Nominally $\leq 10 \Omega$
Output Relay Contact Rating	2 off volt-free/dry change-over contacts 250 V AC, 5 A, 500 VA max resistive 30 V DC, 2 A, 60 W max resistive
Cable Entries	7 x M20 (2 x plugged)

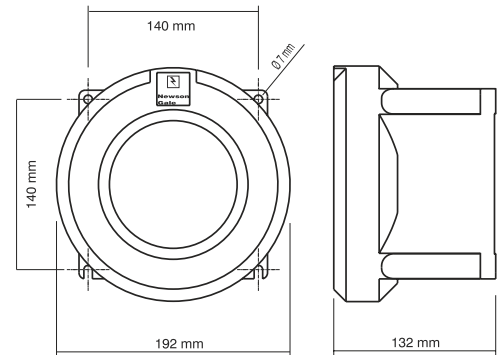

### Junction Box/Stowage Point

Enclosure Material	Static dissipative carbon loaded GRP
Terminals	2 x 2.5 mm <sup>2</sup> conductor capacity
Stowage Device	Insulated universal stowage pin
Cable Entries	1 x 20 mm
Clamp Cable Connection	Quick Connect

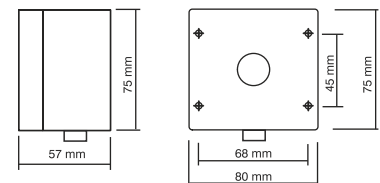

Simple Apparatus  
GRP junction box with nylon grounding clamp  
stowage pin and dust gap

### Grounding Clamp

Clamp Design	Dual core with tungsten carbide teeth
Body	Stainless steel (SS grade: 304)
ATEX / FM / IECEx / UKEX Certification:	ATEX II 1 GD T6 (Assessed to EN 13463-1 : 2009)
UKCA Ex	Ta = -40°C to +60°C Sira 02ATEX9381 ATEX Notified Body: SIRA FM Certificate of Compliance number: 3046346
II 1 G II 1 D Ex h IIC T6 Ga Ex h IIIC T85°C Da Ta = -40°C to +60°C ExVeritas 21UKEX0842 UKCA Ex Approved Body: ExVeritas	IECEx Ex h IIC T6 Ga Ex h IIIC T85°C Da Ta = -40°C to +60°C IECEx EXV 20.0033 IECEx Certified Body: ExVeritas

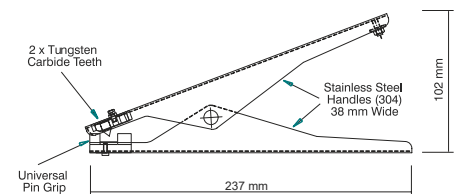

Static Grounding Clamp



Dual core stainless steel grounding clamp fitted with one pair of tungsten carbide tips

### Spiral Cable

Cable	Blue Cen-Stat Hytrel sheath (Static dissipative, chemical & abrasion resistant)
Conductors	2 x 1.00 mm <sup>2</sup> copper
Length	15 m (50 ft) extended (optional cable reel and additional lengths of Hytrel cable available - please enquire)

## Earth-Rite® II MGV Ex d Hazardous Area Certification

### Europe/International

IECEX	<p>Ex db [ia Ga] IIC T6 Gb  Ex tb [ia Da] IIIC T80°C Db  Ta = -40°C to +55°C  IECEX EXV 19.0052  IECEX Certifying Body: ExVeritas</p>
ATEX	<p> II 2(1)G  II 2(1)D  Ex db [ia Ga] IIC T6 Gb  Ex tb [ia Da] IIIC T80°C Db  Ta = -40°C to +55°C  ExVeritas 19ATEX0537  ATEX Notified Body: ExVeritas</p>
UKCA Ex	<p> II 2(1)G  II 2(1)D  Ex db [ia Ga] IIC T6 Gb  Ex tb [ia Da] IIIC T80°C Db  Ta = -40°C to +55°C  ExVeritas 21UKEX0832  UKCA Ex Approved Body: ExVeritas</p>
CCC	<p>Ex db [ia Ga] IIC T6 Gb  Ex tb [ia Da] IIIC T80°C Db  Ta = -40°C to +55°C  2021312304001040  Approved Body: CNEC</p>
KCS (Gas)	<p>Ex d [ia Ga] IIC T6 Gb(Ga)  Ta = -40°C to +55°C  22-AV4BO-0336X  Approved Body: KOSHA</p>
KCS (Dust)	<p>Ex tb IIIC T80°C IP66 Db  Ta = -40°C to +55°C  22-AV4BO-0337X  Approved Body: KOSHA</p>

### North America Version Available

<p>NEC 500 / CEC  (Class &amp; Division)</p>	<p>Associated Equipment [Ex ia] for use in  Class I, Div. 1, Groups A, B, C, D  Class II, Div. 1, Groups E, F, G  Class III, Div. 1  Providing intrinsically safe circuits for  Class I, Div. 1, Groups A, B, C, D  Class II, Div. 1, Groups E, F, G  Class III, Div. 1  Temperature Code T6  Ta = -40°F to +122°F (-40°C to +50°C)  OSHA recognised NRTL: CSA.</p>
<p>NEC 505 &amp; 506  (Class &amp; Zoning)</p>	<p>Class I, Zone 1 [0] AEx d[ia] IIC T6 Gb(Ga)  Class II, Zone 21 [20] AEx tD [iaD] 21 T80°C</p>
<p>CEC Section 18  (Class &amp; Zoning)</p>	<p>Class I, Zone 1[0] Ex d[ia] IIC T6 Gb(Ga)  DIP A21, IP66, T80°C</p>

### Additional Certification

Safety Integrity Level	SIL 2 (in accordance with IEC/EN 61508)
EMC Tested	to EN 61000-6-3, EN 61000-6-2 FCC - Part 15 (Class B)

# Earth-Rite® II PLUS

Precision and reliability of the **Earth-Rite® II PLUS** provides **QHSE** professionals and engineers who are tasked with protecting personnel and plant assets from the ignition hazards of static electricity during railcar, skid, and Ex IBC loading/unloading operations.

The **Earth-Rite® II PLUS** is the ideal solution for grounding and bonding a broad range of equipment at risk of igniting combustible gases and vapours.



The **Earth-Rite® II PLUS** is a flexible active ground monitoring system that enables the static grounding of a wide range of metal 'objects' used in Ex atmospheres.

Such objects include, but are not limited to:

- Metal Drums
- Metal Frames of Ex IBCs
- Railcars
- Pump Metering Skids



## KEY FEATURES

### Active Resistance Monitoring

- Actively monitors the resistance of the circuit between the object (e.g., metal drum or metal frame of Ex IBC) and the plant's designated grounding point to 10 ohm or less.

### Clear Visual Indicators

- One solid red and three flashing green LEDs provide easy to understand "GO/NO-GO" indication to operators.
- Positive ground connection indicated via high intensity green flashing LEDs for their attention-grabbing effect. Flashing operation can aid operators with colour blindness.

### No Calibration Required

- The system does not require calibration at installation or during its lifecycle, ensuring ease of use and maintenance.

### Volt-Free/Dry Contacts

- Standard option of specifying either intrinsically safe and/or non-intrinsically safe volt-free contacts for controlling process equipment.

### Maintenance Support

- Can be supplied with a tester for maintenance personnel to validate the operating parameters as part of a routine maintenance schedule.

### Heavy-Duty Grounding Clamp

- Utilises a heavy-duty stainless steel clamp, that combines sharpened tungsten carbide teeth with a strong torsion spring to establish, and maintain, a positive connection to the object for the duration of the processing operation.

### IEC Compliance for Ex Areas

- Grounding clamps do not contain any insulating materials (rubber/plastic) that exceed the volume or surface area for Ex areas as specified in IEC TS 60079-32-1.

### Wide Ex Installation Compatibility

- Can be installed in all gas groups (IIA, IIB, IIC) and all dust groups (IIIA, IIIB, IIIC).

### Flexible Cable Options

- Can be specified with anti-static cable in a spiral format or as part of a 2-core retractable cable reel.
- Wide range of national and internationally recognised Ex certificates.

# Earth-Rite® II PLUS

The Earth-Rite® II PLUS is the ideal solution for grounding and bonding a broad range of equipment at risk of igniting combustible gases and vapours.

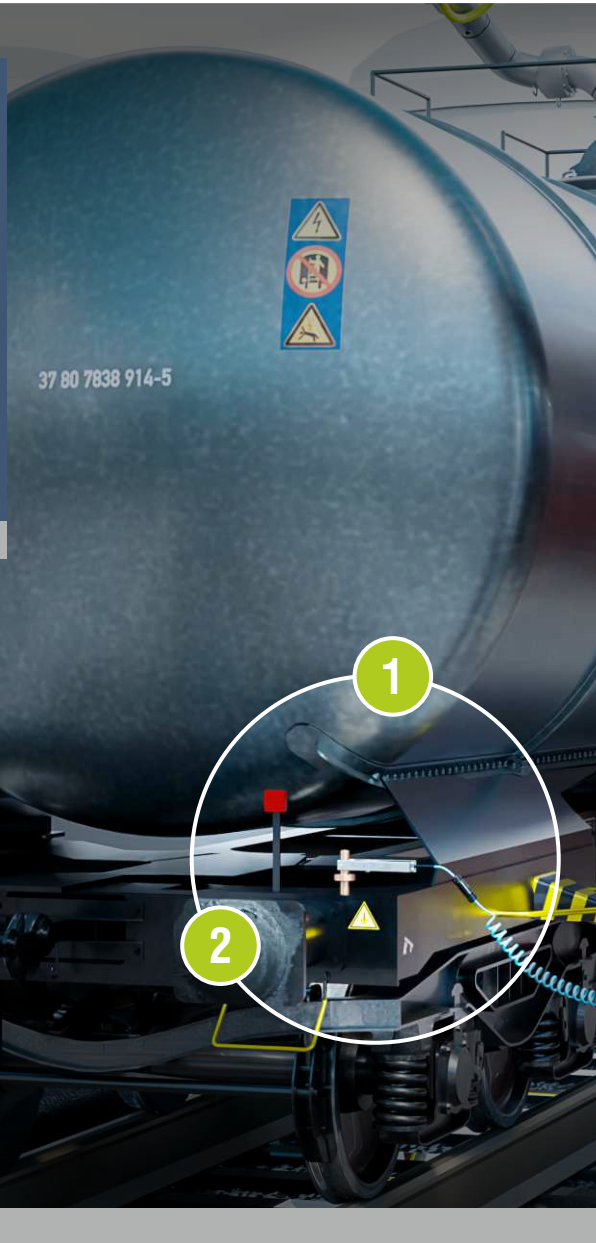

## 1

### Active Monitoring

Actively monitors the resistance of the circuit between the connection to the rail tanker and the loading gantry's designated grounding point to 10 ohms or less.

**DOES NOT** require calibration at installation or throughout its lifecycle.

## 2

### Heavy-Duty Grounding Clamp

Utilises a heavy-duty stainless steel clamp, that combines sharp tungsten carbide teeth with a strong torsion spring to establish, and maintain, a positive connection to the rail tanker for the duration of the loading/unloading operation.

Grounding clamps **DO NOT** contain any insulating materials (rubber/plastic) that exceed the volume or surface area for Ex areas as specified in IEC TS 60079-32-1 (does not require rubber handle).

## 3

### Installation Flexibility

Can be installed in all gas groups (IIA, IIB and IIC) and all dust groups (IIIA, IIIB and IIIC).

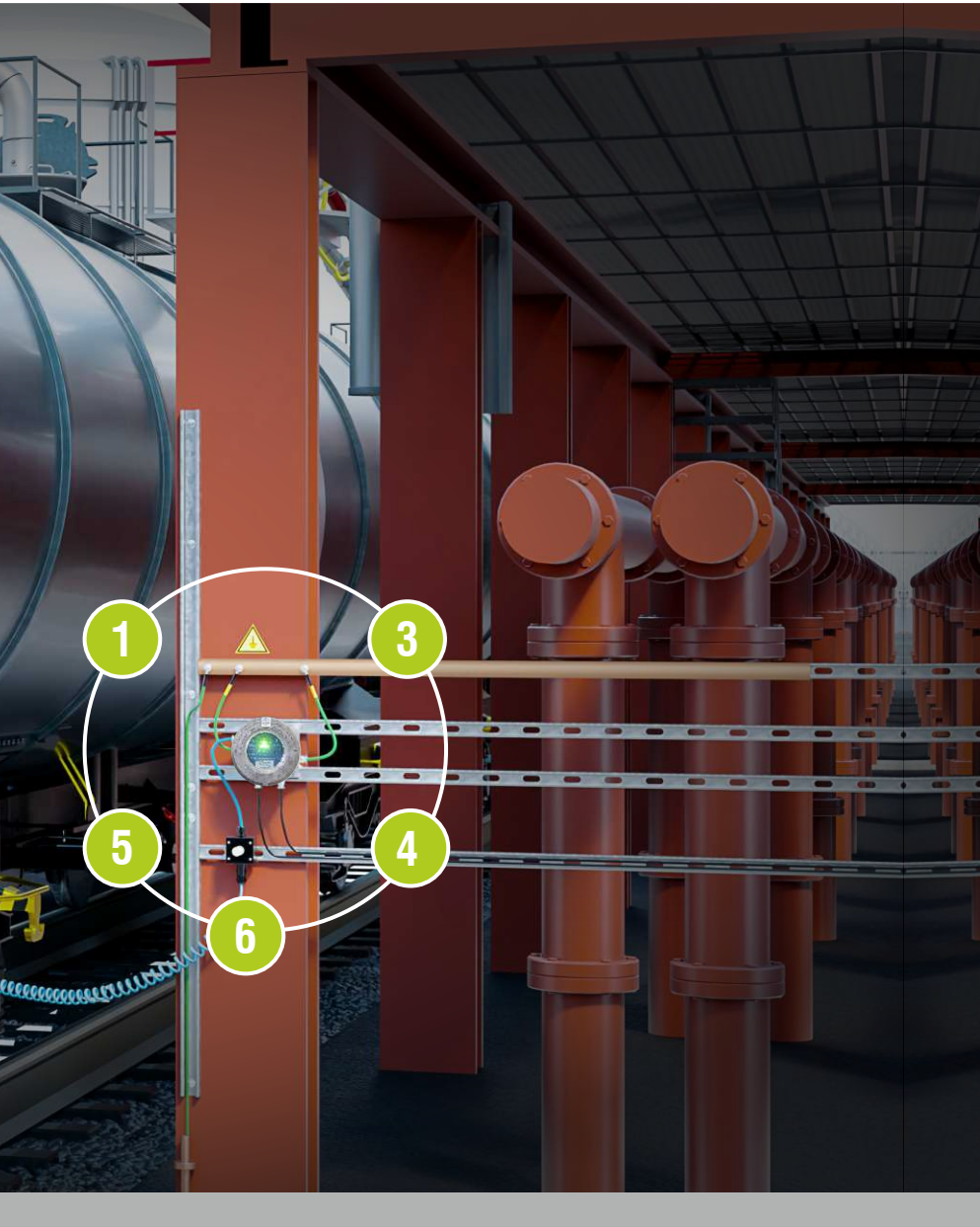

# 6

## Clamp Stowage Point

Enables operators to stow the clamp and cable when the grounding system is not in use.

# 4

## Clear "GO/NO-GO" Indication

One solid red and three green high intensity flashing LEDs provide easy to understand "GO" or "NO-GO" indication to operators. Positive ground connection is indicated via one solid red and three green high intensity flashing LEDs providing operators with a clear "GO/NO-GO" indication which can also aid operators with colour blindness.

# 5

## Interlocks

Standard non-intrinsically safe volt-free contacts and optional intrinsically safe contacts for controlling process equipment (e.g., pumps).



Scan QR Code to make an enquiry

## Earth-Rite® II PLUS Ex d Technical Specification

Ex d (Zone 1 Gas / Vapour Atmosphere - Zone 21 Dust Atmospheres)

### Power Supply & Monitoring Unit

Power Supply	115 V or 230 V AC, 50-60 Hz 12 V or 24 V DC
Power Rating	10 watt
Ambient Temperature Range	-40°C to +55°C
Ingress Protection	IP66
Weight	4.5 kgs (9.9 lbs) net
Construction	Copper-free cast aluminium
Monitoring Circuit	Intrinsically safe "ia"
Monitoring Loop Resistance	Nominally $\leq 10 \Omega$
Output Relay Contact Rating	2 off volt-free/dry change-over contacts 250 V AC, 5 A, 500 VA max resistive 30 V DC, 2 A, 60 W max resistive
Cable Entries	7 x M20 (2 x plugged)

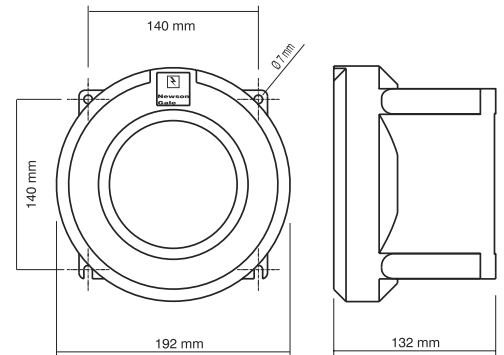

### Junction Box/Storage Point

Enclosure Material	Static dissipative carbon loaded GRP
Terminals	2 x 2.5 mm <sup>2</sup> conductor capacity
Storage Device	Insulated universal stowage pin
Cable Entries	1 x 20 mm
Clamp Cable Connection	Quick Connect

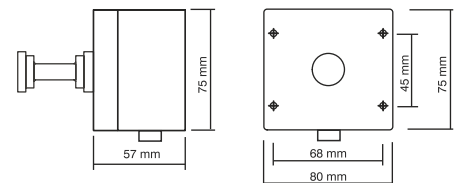

Simple Apparatus  
GRP junction box with nylon grounding clamp stowage pin

### Grounding Clamp

Clamp Design	Dual core with tungsten carbide teeth
Body	Stainless steel (SS grade: 304)
ATEX / FM / IECEx / UKEX Certification:	ATEX II 1 GD T6 (Assessed to EN 13463-1 : 2009) Ta = -40°C to +60°C Sira 02ATEX9381 ATEX Notified Body: SIRA FM Certificate of Compliance number: 3046346
UKCA Ex Certification:	IECEX Ex h IIC T6 Ga Ex h IIIC T85°C Da Ta = -40°C to +60°C ExVeritas 21UKEX0842 UKCA Ex Approved Body: ExVeritas

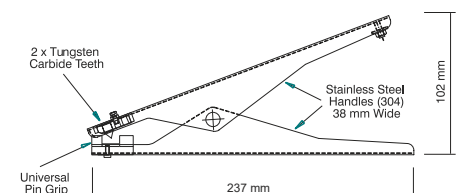



Static Grounding Clamp  
Dual core stainless steel grounding clamp fitted with one pair of tungsten carbide tips

### Spiral Cable

Cable	Dual core Cen-Stat blue spiral cable with Hytel coating which has UV and static dissipative additives
Conductors	2 x 1.00 mm <sup>2</sup> copper
Length	3 m (10 ft), 5 m (16 ft), 10 m (32 ft) or 15 m (50 ft)

## Earth-Rite® II PLUS Ex d Hazardous Area Certification

Europe/International		North America Version Available	
IECEX	Ex db [ia Ga] IIC T6 Gb Ex tb [ia Da] IIIC T80°C Db Ta = -40°C to +55°C IECEX EXV 19.0052 IECEX Certifying Body: ExVeritas	NEC 500 / CEC (Class & Division)	Associated Equipment [Ex ia] for use in Class I, Div. 1, Groups A, B, C, D Class II, Div. 1, Groups E, F, G Class III, Div. 1 Providing intrinsically safe circuits for Class I, Div. 1, Groups A, B, C, D Class II, Div. 1, Groups E, F, G Class III, Div. 1 Temperature Code T6 Ta = -40°F to +122°F (-40°C to +50°C) OSHA recognised NRTL: CSA
ATEX	 II 2(1)G II 2(1)D Ex db [ia Ga] IIC T6 Gb Ex tb [ia Da] IIIC T80°C Db Ta = -40°C to +55°C ExVeritas 19ATEX0537 ATEX Notified Body: ExVeritas	NEC 505 & 506 (Class & Zoning)	Class I, Zone 1 [0] AEx d[ia] IIC T6 Gb(Ga) Class II, Zone 21 [20] AEx tD [iaD] 21 T80°C
UKCA Ex	 II 2(1)G II 2(1)D Ex db [ia Ga] IIC T6 Gb Ex tb [ia Da] IIIC T80°C Db Ta = -40°C to +55°C ExVeritas 21UKEX0832 UKCA Ex Approved Body: ExVeritas	CEC Section 18 (Class & Zoning)	Class I, Zone 1[0] Ex d[ia] IIC T6 Gb(Ga) DIP A21, IP66, T80°C
CCC	Ex db [ia Ga] IIC T6 Gb Ex tb [ia Da] IIIC T80°C Db Ta = -40°C to +55°C 2021312304001040 Approved Body: CNEX	<b>Additional Certification</b>	
KCS (Gas)	Ex d [ia Ga] IIC T6 Gb(Ga) Ta = -40°C to +55°C 22-AV4BO-0332X Approved Body: KOSHA	Safety Integrity Level	SIL 2 (in accordance with IEC/EN 61508)
KCS (Dust)	Ex tb IIIC T80°C IP66 Db Ta = -40°C to +55°C 22-AV4BO-0333X Approved Body: KOSHA	EMC Tested	to EN 61000-6-3, EN 61000-6-2 FCC - Part 15 (Class B)

## Earth-Rite® II PLUS GRP Technical Specification

For single unit installation in Zone 2 and 21 Ex hazardous areas

### Power Supply & Monitoring-Unit

Power Supply	115 V or 230 V AC, 50-60 Hz 12 V or 24 V DC
Power Rating	10 watt
Ambient Temperature Range	-40°C to +55°C
Ingress Protection	IP66
Weight	2 kgs (4.4 lbs) net
Construction	Static dissipative carbon loaded GRP
Monitoring Circuit	Intrinsically safe "ia"
Monitoring Loop Resistance	Nominally $\leq 10 \Omega$
Output Relay Contact Rating	2 off volt-free/dry change-over contacts 250 V AC, 5 A, 500 VA max resistive 30 V DC, 2 A, 60 W max resistive
Cable Entries	7 x M20 (2 x plugged)

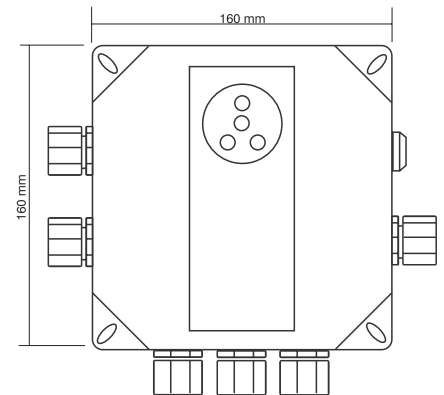

### Junction Box/Stowage Point

Enclosure Material	Static dissipative carbon loaded GRP
Terminals	2 x 2.5 mm <sup>2</sup> conductor capacity
Stowage Device	Insulated universal stowage pin
Cable Entries	1 x 20 mm
Clamp Cable Connection	Quick Connect

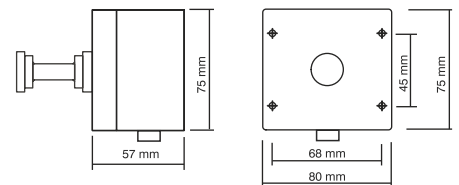

Simple Apparatus  
GRP junction box with nylon grounding clamp stowage pin

### Grounding Clamp

Clamp Design	Dual core with tungsten carbide teeth
Body	Stainless steel (SS grade: 304)
ATEX / FM / IECEx / UKEX Certification:	ATEX II 1 GD T6 (Assessed to EN 13463-1 : 2009)
UKCA Ex II 1 G II 1 D Ex h IIC T6 Ga Ex h IIIC T85°C Da Ta = -40°C to +60°C ExVeritas 21UKEX0842 UKCA Ex Approved Body: ExVeritas	Sira 02ATEX9381 ATEX Notified Body: SIRA FM Certificate of Compliance number: 3046346
	IECEX Ex h IIC T6 Ga Ex h IIIC T85°C Da Ta = -40°C to +60°C IECEX EXV 20.0033 IECEX Certified Body: ExVeritas

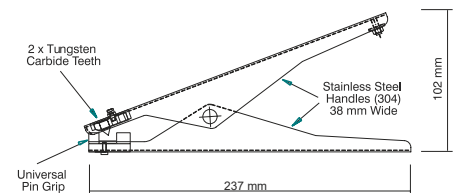



Static Grounding Clamp

Dual core stainless steel grounding clamp fitted with one pair of tungsten carbide tips

### Spiral Cable

Cable	Dual core Cen-Stat blue spiral cable with Hytrel coating which has UV and static dissipative additives
Conductors	2 x 1.00 mm <sup>2</sup> copper
Length	3 m (10 ft), 5 m (16 ft), 10 m (32 ft) or 15 m (50 ft)

## Earth-Rite® II PLUS GRP Hazardous Area Certification

Europe/International		North America Version Available	
IECEX	Ex ec nC [ia Ga] IIC T4 Gc Ex tb [ia Da] IIIC T70°C Db Ta = -40°C to +55°C IECEX EXV 19.0059X IECEX Certifying Body: ExVeritas	NEC 500 / CEC (Class & Division)	Associated Equipment [Ex ia] for use in Class I, Div. 2, Groups A, B, C, D Class II, Div. 2, Groups E, F, G Class III, Div. 2 Providing Intrinsically Safe circuits for Class I, Div. 1, Groups A, B, C, D Class II, Div. 1, Groups E, F, G Class III, Div. 1 Temperature Code T4 Ta = -13°F to +131°F (-25°C to +55°C) OSHA recognised NRTL: CSA
ATEX	 II 3(1)G II 2(1)D Ex ec nC [ia Ga] IIC T4 Gc Ex tb [ia Da] IIIC T70°C Db Ta = -40°C to +55°C ExVeritas 19ATEX0545X ATEX Notified Body: ExVeritas	NEC 505 & 506 (Class & Zoning)	Class I, Zone 2, (Zone 0), AEx nA[ia] IIC T4 Class II, Zone 21, AEx tD[iaD] 21, T70°C
UKCA Ex	 II 3(1)G II 2(1)D Ex ec nC [ia Ga] IIC T4 Gc Ex tb [ia Da] IIIC T70°C Db Ta = -40°C to +55°C ExVeritas 21UKEX0833X UKCA Ex Approved Body: ExVeritas	CEC Section 18 (Class & Zoning)	Class I, Zone 2 (Zone 0) Ex nA[ia] IIC T4 DIP A21, IP66, T70°C
CCC	Ex ec [ia Ga] nC IIC T4 Gc Ex tb [ia Da] IIIC T70°C Db Ta = -40°C to +55°C 2021312304001041 Approved Body: CNEX	<b>Additional Certification</b>	
KCS (Gas)	Ex ec nC [ia Ga] IIC T4 Gc(Ga) Ta = -40°C to +55°C 22-AV4BO-0315X Approved Body: KOSHA	Safety Integrity Level	SIL 2 (in accordance with IEC/EN 61508)
KCS (Dust)	Ex tb IIIC T70°C Db Ta = -40°C to +55°C 22-AV4BO-0316X Approved Body: KOSHA	EMC Tested	To EN 61000-6-3, EN 61000-6-2 FCC - Part 15 (Class B)

# Earth-Rite® MULTIPOINT II

The **Earth-Rite® MULTIPOINT II** grounds and monitors multiple items of equipment at points like multi-drum loading stations and mixing stations, Ex IBC loading stations and railcar loading gantries, to minimise the accumulation of static electricity.

The **Earth-Rite® MULTIPOINT II** from Newson Gale is a single grounding system with eight independent active earth monitoring circuits.

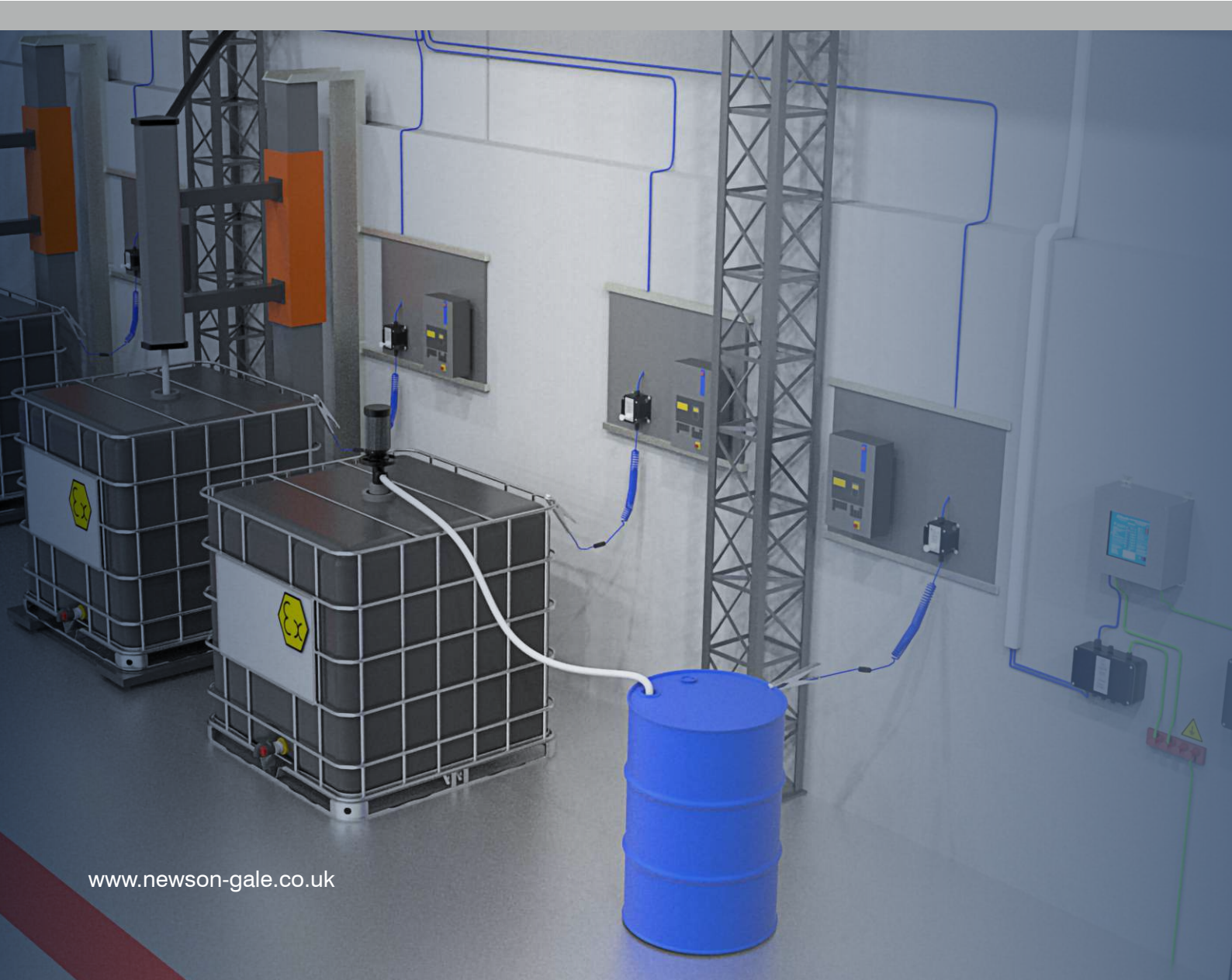

## 8

## Eight x Independent Ground Monitoring

- Monitors the ground status of up to eight discrete pieces of equipment in Ex atmospheres.
- With eight separate active monitoring circuits, each with dedicated interlock and high intensity, solid red and flashing green LED indicators.



## KEY FEATURES

### Intrinsically Safe Design (Ex ia)

- Certified for Zone 0 and Zone 20 areas, ensuring safe operation in hazardous gas, vapour, and dust environments.

### Simple Visual Indicators

- Green and red LEDs use a "GO/NO GO" method to signal whether the ground resistance is below 10 ohms, a threshold defined by industry best practices.

### Relay Activation

- If ground status is in a permissive state, a volt-free relay is energised to signal the condition to the operator or connected systems.

### Configurable Monitoring Circuits

- Monitoring circuits can be activated or deactivated via DIP switches on the monitoring unit's front panel.

### Remote Indicators for Visibility

- Additional remote indicator stations can be mounted at connection points, with intrinsically safe Ex ia LED indicators for locations where the main LED array is not visible.

### Flexible Grouping of Monitoring Circuits

- Monitoring channels can be grouped for applications requiring multiple equipment pieces to be earthed before activation, e.g., for loading pumps or fluid bed dryers.

### Communication and Power Supply

- Power supplied via an intrinsically safe unit installed in Zone 2/21 or non-hazardous areas.
- Communication between monitoring unit and power supply via CAN-bus.
- Power supply unit includes volt-free relays for integration with PLCs or electromechanical equipment.

### Fault Detection and Diagnostics

- SIL 2 rated system.
- Self-checking technology; detected hardware faults trigger non-permissive states and red LED fault indicators.
- Watchdog timer circuit ensures the software operates correctly, with a flashing blue LED indicating active monitoring.
- Faults in communication between the monitoring unit and power supply are signalled by a fault relay.

# Earth-Rite® MULTIPOINT II

Newson Gale's single grounding system with eight independent active earth monitoring circuits.



## 1

### Remote Indicator Station

Optional remote indicator station can be located at points where the equipment to be grounded is outside the field of view of the monitoring unit.

Remote indicator stations utilise intrinsically safe circuits (ia) to power high intensity static red or green flashing LED indicators, and can be mounted in all Zones and all gas and dust groups.



## 2

### Heavy-Duty Grounding Clamp

Utilises a heavy-duty stainless steel clamp, that combines sharp tungsten carbide teeth with a strong torsion spring to establish, and maintain, a positive connection for the duration of the loading/unloading operation.

Grounding clamps **DO NOT** contain any insulating materials (rubber/plastic) that exceed the volume or surface area for Ex areas as specified in IEC TS 60079-32-1 (does not require rubber handle).

## 3

### Clear "GO/NO-GO" Indication

Monitoring unit contains eight pairs of solid red and green high intensity flashing LED indicators that inform operators of the ground status of the equipment requiring static grounding.

Operators do not need to interact with switches or resistance readings – the system will inform the operators on the equipment's ground status as soon as the clamp or connector is attached to the equipment.

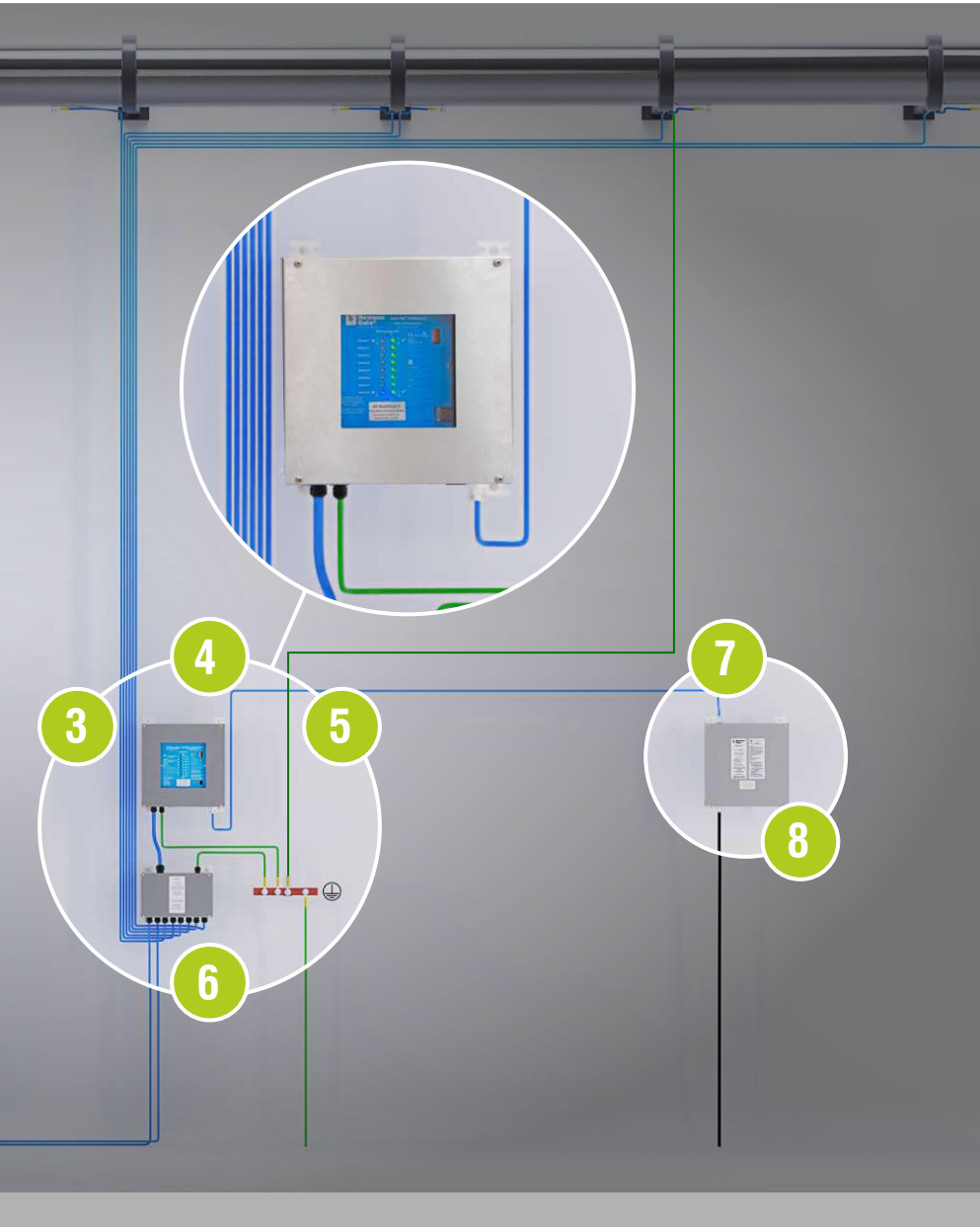

# 8

## Interlocks

Each ground monitoring circuit has its own dedicated relay.

Multiple monitoring circuits can control a group relay.

A single fault relay provides a safety shutdown function if specific operating parameters are not being met.

# 7

## PSU

The Earth-Rite® MULTIPOINT II PSU (power supply unit) can be installed in Zone 2/21.

# 6

## Ground Monitoring Circuits

Eight ground monitoring circuits are provided in a single system.

Uses the highest level of intrinsically safe “ia” monitoring circuits which can be connected to equipment being used in Zone 0/Zone 20 and all gas and dust groups.

# 4

## Active Monitoring

Actively monitors the resistance of the circuit between the connection to the metal objects and the verified earth point to 10 ohms or less.

**DOES NOT** require calibration at installation or throughout its lifecycle.

# 5

## Monitoring Unit

The Earth-Rite® MULTIPOINT II monitoring unit can be installed in Zone 0/20.



Scan QR Code to make an enquiry

## Earth-Rite® MULTIPOINT II Technical Specification (With GRP Power Supply)

### Monitoring Unit - Zone 0/20 Installations

Ambient Temperature Range	-40°C to +60°C
Ingress Protection	IP66
Construction	Stainless Steel (SS grade: 316L)
Monitoring Circuit	Intrinsically safe "ia"
Monitoring Loop Resistance	Nominally $\leq 10 \Omega$
Cable Entries	3 x M20, 1 x M25

### Power Supply Unit - Zone 2/21 Installations

Power Supply	115 V or 230 V AC, 50-60 Hz
Current Rating	200 mA
Power Rating	10 watts
Ambient Temperature Range	-40°C to +60°C
Ingress Protection	IP 66
Construction	GRP with carbon loading
Output to Monitoring Unit	Intrinsically safe
Output Channel Relay	8 off volt-free/dry change-over contacts
Output Group Relay	2 off volt-free/dry change-over contacts
Output Fault Relay	1 off volt-free/dry change-over contacts
Relay Contact Rating	240 V AC, 5 A, 500 VA max resistive 30 V DC, 2 A, 60 W max resistive
Cable Entries	12 x M20

### Marshalling Junction Box

Enclosure Material	Static dissipative carbon loaded GRP
Cable Entries	8 Way - 10 x M20, 1 x M25 4 Way - 6 x M20, 1 x M25

### Remote Indicator Station Associated Apparatus - Zone 0/20 installation

Enclosure Material	Static dissipative carbon loaded GRP
Cable Entries	1 x M20

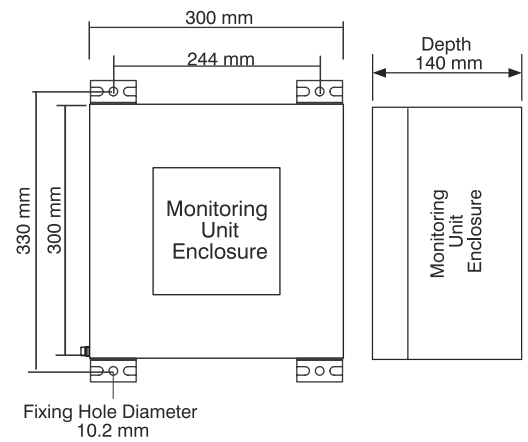

Fixing Hole Diameter  
10.2 mm

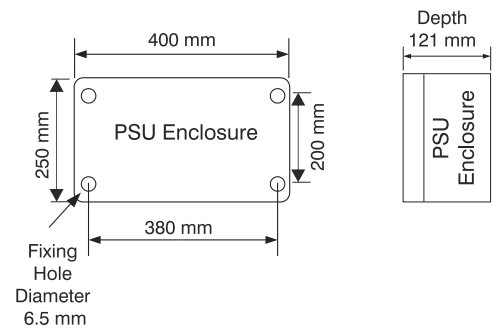

Fixing Hole Diameter  
6.5 mm

Product Description	Length	Height	Depth
8-Way Junction Box	259 mm	160 mm	91.4 mm
4-Way Junction Box	160 mm	160 mm	94 mm
Remote Indicator Station	122 mm	122 mm	76.2 mm
Junction Box with Stowage Pin	80 mm	76.2 mm	55.9 mm

For more detailed mechanical descriptions please refer to instruction manual

**Earth-Rite® MULTIPOINT II Technical Specification**  
(With Stainless Steel Power Supply)

**Monitoring Unit - Zone 0/20 Installations**

Ambient Temperature Range	-40°C to +60°C
Ingress Protection	IP66
Construction	Stainless Steel (SS grade: 304)
Monitoring Circuit	Intrinsically safe "ia"
Monitoring Loop Resistance	Nominally ≤10 Ω
Cable Entries	3 x M20, 1 x M25

**Power Supply Unit - Zone 2/21 Installations**

Power Supply	115 V or 230 V AC, 50-60 Hz
Current Rating	200 mA
Power Rating	10 watts
Ambient Temperature Range	-40°C to +60°C
Ingress Protection	IP 66
Construction	Stainless Steel (SS grade: 316L)
Output to Monitoring Unit	Intrinsically safe
Output Channel Relay	8 off volt-free/dry change-over contacts
Output Group Relay	2 off volt-free/dry change-over contacts
Output Fault Relay	1 off volt-free/dry change-over contacts
Relay Contact Rating	240 V AC, 5 A, 500 VA max resistive 30 V DC, 2 A, 60 W max resistive
Cable Entries	12 x M20

**Marshalling Junction Box**

Enclosure Material	Stainless Steel (SS grade: 316L)
Cable Entries	8 Way - 10 x M20, 1 x M25 4 Way - 6 x M20, 1 x M25

**Remote Indicator Station Associated Apparatus - Zone 0/20 installation**

Enclosure Material	Stainless Steel (SS grade: 316L)
Cable Entries	1 x M20

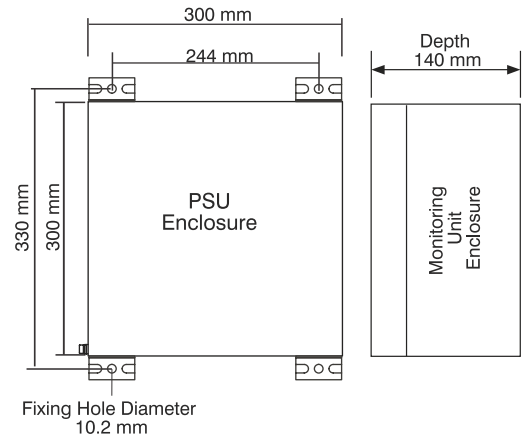
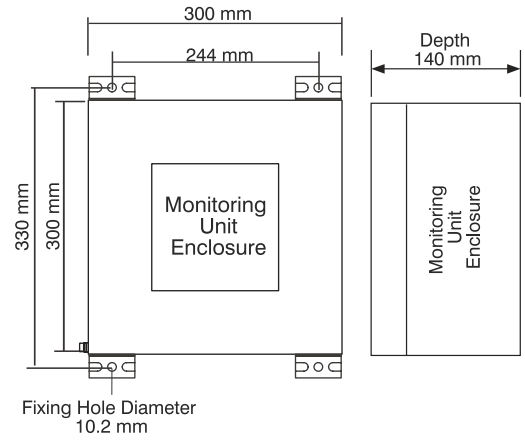



Product Description	Length	Height	Depth
8-Way Junction Box	300 mm	200 mm	81 mm
4-Way Junction Box	150 mm	150 mm	81 mm
Remote Indicator Station	150 mm	150 mm	81 mm
Junction Box with Stowage Pin	150 mm	150 mm	81 mm

For more detailed mechanical descriptions please refer to instruction manual



## Earth-Rite® MULTIPOINT II Hazardous Area Certification

### Monitoring Unit

Europe/International		North America Version Available	
IECEX	Ex ia IIC T4 Ga Ex ia IIIC T135°C Da Ta = -40°C to +60°C IECEX EXV 19.0062X IECEX Certifying Body: ExVeritas		Suitable for use In Class I, Div. 1, Groups A, B, C, D Class II, Div. 1, Groups E, F, G Class III, Div. 1 Provides intrinsically safe output for Class I, Div. 1, Groups A, B, C, D; Class II, Div. 1, Groups E, F, G Class III, Div. 1; Temperature Code T4 Ta = -40°F to +140°F (-40°C to +60°C) OSHA recognised NRTL: CSA CSA 15.70005381
ATEX	 II 1 G II 1 D Ex ia IIC T4 Ga Ex ia IIIC T135°C Da Ta = -40°C to +60°C ExVeritas 19ATEX0546X ATEX Notified Body: ExVeritas	NEC 500 / CEC (Class & Division)	
UKCA Ex	 II 1 G II 1 D Ex ia IIC T4 Ga Ex ia IIIC T135°C Da Ta = -40°C to +60°C ExVeritas 21UKEX0837X UKCA Ex Approved Body: ExVeritas	NEC 505 & 506 (Class & Zoning)	Class I, Zone 0, AEx ia IIC T4 Ga Class II, Zone 20, AEx ia IIIC T135°C Da
CCC	Ex ia IIC T4 Ga Ex ia IIIC T135°C Da 2021312309000479 Approved Body: KOSHA	CEC Section 18 (Class & Zoning)	Ex ia IIC T4 Ga Ex ia IIIC T135°C Da
KCS (Gas)	Ex ia IIIC T135°C Da Ta = -40°C to +60°C 22-AV4BO-0344X Approved Body: KOSHA	<b>Additional Certification</b>	
KCS (Dust)	Ex ia IIIC T135°C Da Ta = -40°C to +60°C 22-AV4BO-0345X Approved Body: KOSHA	EMC Tested	to EN 61000-6-2, EN 61000-6-3 FCC - Part 15

## Earth-Rite® MULTIPOINT II Hazardous Area Certification

### Power Supply Unit

Europe/International		North America Version Available	
IECEX	Ex ec nC [ia Ga] IIC T4 Gc Ex tb [ia Da] IIIC T65°C Db Ta = -40°C to +60°C IECEX EXV 19.0062X IECEX Certifying Body: ExVeritas		Suitable for use In Class I, Div. 2, Groups A, B, C, D Class II, Div. 1, Groups E, F, G Class III, Div. 1 Provides intrinsically safe output for Class I, Div. 1, Groups A, B, C, D; Class II, Div. 1, Groups E, F, G Class III, Div. 1; Temperature Code T4 Ta = -40°F to +140°F (40°C to +60°C) OSHA recognised NRTL: CSA CSA 15.70005381
ATEX	 II 3(1)G II 2(1)D Ex ec nC [ia Ga] IIC T4 Gc Ex tb [ia Da] IIIC T65°C Db Ta = -40°C to +60°C ExVeritas 19ATEX0546X ATEX Notified Body: ExVeritas	NEC 500 / CEC (Class & Division)	
UKCA Ex	 II 3(1)G II 2(1)D Ex ec nC [ia Ga] IIC T4 Gc Ex tb [ia Da] IIIC T65°C Db Ta = -40°C to +60°C ExVeritas 21UKEX0837X UKCA Ex Approved Body: ExVeritas	NEC 505 & 506 (Class & Zoning)	Class I, Zone 2, AEx nA[ia Ga] nC IIC T4 Gc Class II, Zone 21, AEx tb IIIC T65°C Db
CCC	Ex ec [ia Ga] nC IIC T4 Gc Ex tb IIIC T65°C Db Ta = -40°C to +60°C 2021312309000479 Approved Body: CNEX	CEC Section 18 (Class & Zoning)	Ex nA[ia Ga] nC IIC T4 Gc Ex tb IIIC T65°C Db
KCS (Gas)	Ex ec [ia Ga] nC IIC T4 Gc Ta = -40°C to +60°C 22-AV4BO-0346X Approved Body: KOSHA	<b>Additional Certification</b>	
KCS (Dust)	Ex tb IIIC T65°C Db Ta = -40°C to +60°C 22-AV4BO-0347X Approved Body: KOSHA	EMC Tested	to EN 61000-6-2, EN 61000-6-3 FCC - Part 15

# Earth-Rite® DGS

Precision and reliability of the **Earth-Rite® DGS** protecting plant and professional engineers from the hazards associated with electrostatic discharge.

The **Earth-Rite® DGS** is the ideal solution for grounding up to two bulk transportation vehicles or other objects to be grounded simultaneously.



The **Earth-Rite® DGS** is a flexible system for when one or two plant items need to be grounded simultaneously and both of their grounding connections monitored to less than 10 ohms as required by International Standards Guidance and/or Recommended Practices.

Typical applications, but are not limited to:

- Two Metal Drums
- Two Ex IBCs
- Two Railcars
- Transloading (Railcar to Truck or Truck to Railcar)
- LACT (Lease Automatic Custody Transfer) Skids

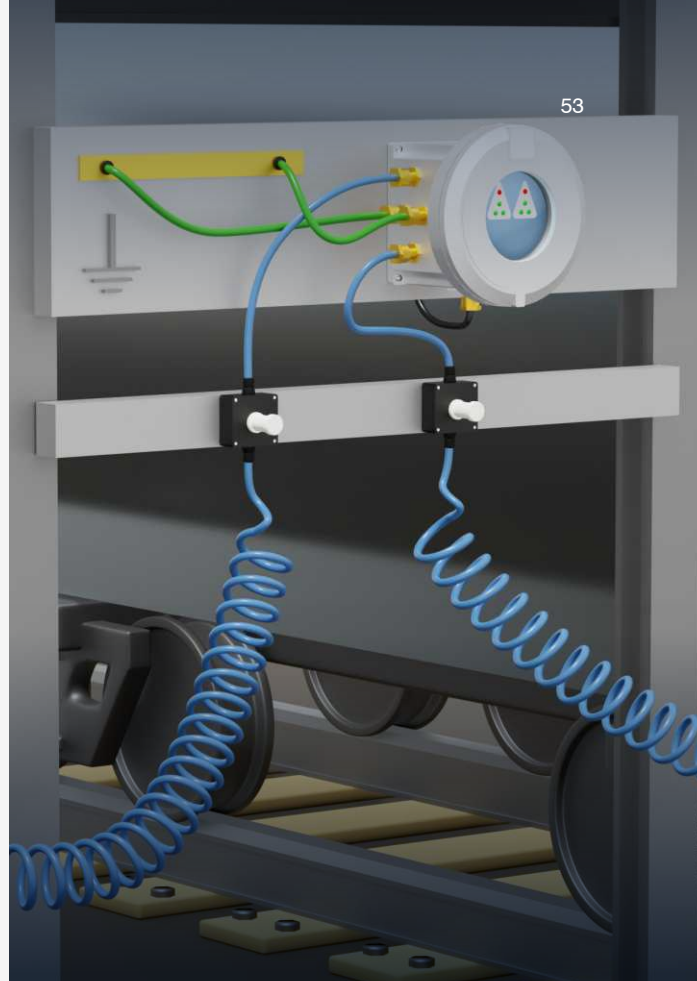

## KEY FEATURES

### Active Resistance Monitoring

- Actively monitors the resistance of the circuit between the object (e.g., metal drum or metal frame of Ex IBC) and the plant's designated grounding point to 10 ohms or less.

### Clear Visual Indicators

- One solid red and three flashing green LEDs provide easy to understand "GO/NO-GO" indication to operators.
- Positive ground connection indicated via high intensity green flashing LEDs for their attention-grabbing effect. Flashing operation can aid operators with colour blindness.

### Heavy-Duty Grounding Clamp

- Utilises a heavy-duty stainless steel clamp, that combines sharpened tungsten carbide teeth with a strong torsion spring to establish, and maintain, a positive connection to the object for the duration of the processing operation.

### IEC Compliance for Ex Areas

- Grounding clamps do not contain any insulating materials (rubber/plastic) that exceed the volume or surface area for Ex areas as specified in IEC TS 60079-32-1.

### Wide Ex Installation Compatibility

- Can be installed in all gas groups (IIA, IIB, IIC) and all dust groups (IIIA, IIIB, IIIC).

### Flexible Cable Options

- Available with static dissipative cable in spiral format or as part of a 2-core retractable cable reel.

### Reliable Volt-Free/Dry Contacts

- Dedicated interlock relay contacts for each channel and a group relay is available.
- **Benefit:** Enhances control over process equipment, providing options that can be tailored to specific safety and operational needs.

# Earth-Rite® DGS

Newson Gale's dual grounding system with system interlocks and visual indication.

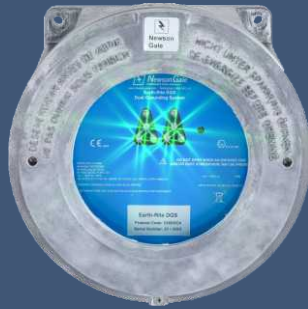

## 1

### Active Monitoring

Actively monitors the resistance of the circuit between the connection to the road tanker and the loading gantry's designated grounding point to 10 ohms or less.

**DOES NOT** require calibration at installation or throughout its lifecycle.

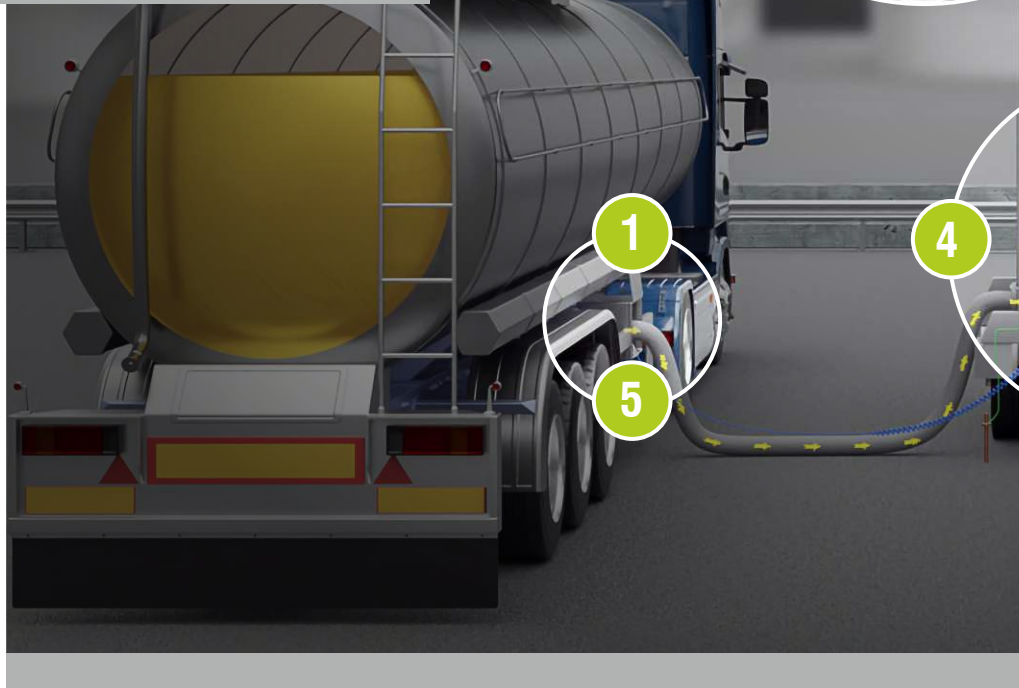

## 2

### Interlocks

Both ground monitoring circuits has its own dedicated relay. The monitoring circuits can also control a master relay.

## 3

### Dual Channel Monitoring Circuits

Provides two channels that each independently grounds and monitors back to the local ground bar with a resistance of 10 ohms or less.

## 4

### Clamp Stowage Point

Enables operators to stow the clamp and cable when the grounding system is not in use.

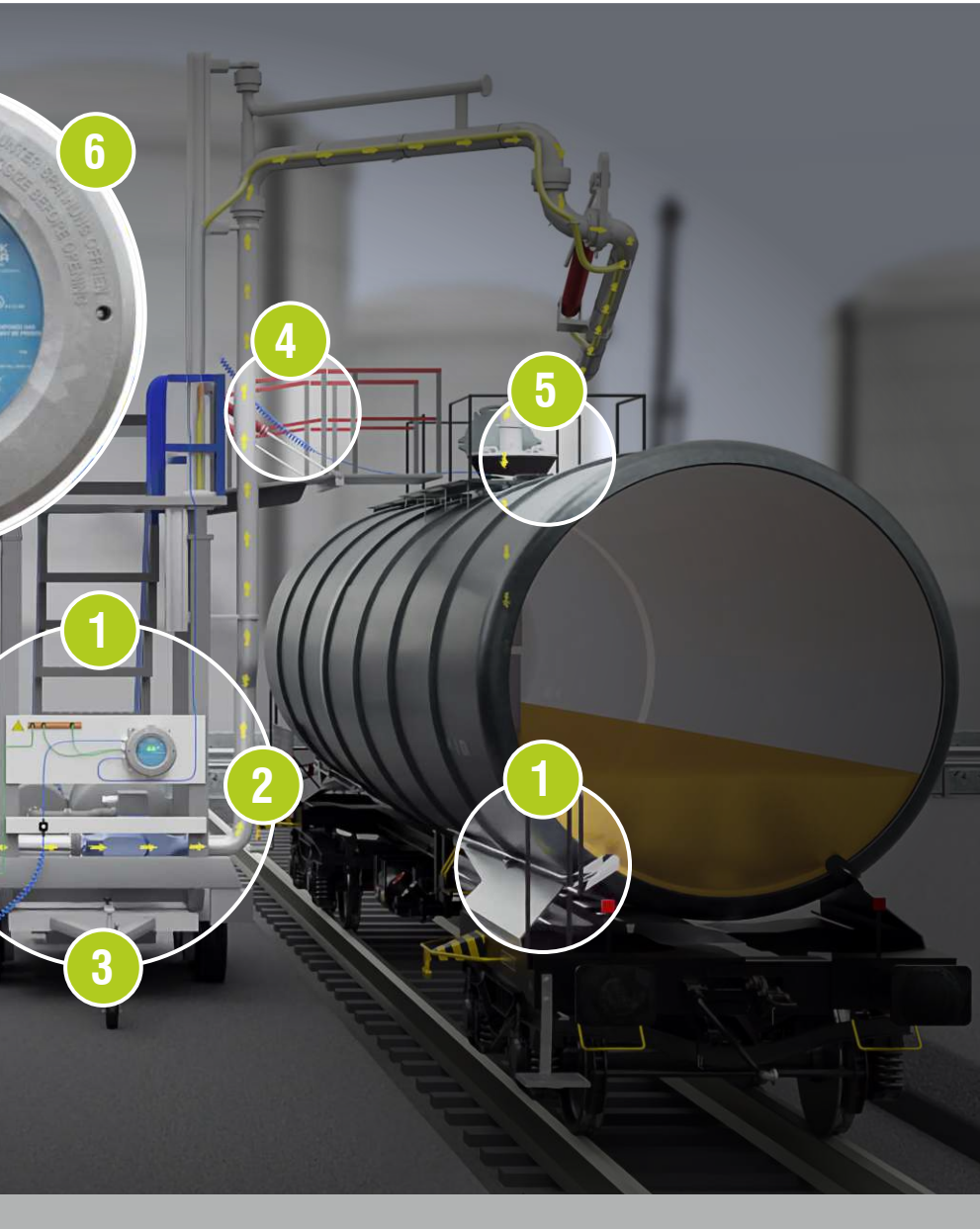

# 5

## Heavy-Duty Grounding Clamps

Clamps can be used in Zone 0/20 and all gas groups (IIA, IIB and IIC), including hydrogen, and all dust groups (IIIA, IIIB and IIIC).

# 6

## Clear “GO/NO-GO” Indication

Both channels have a solid red and three flashing green LEDs that provide easy to understand “GO” or “NO-GO” indication to operators. Positive ground connection indicated via high intensity green flashing LEDs for their attention-grabbing effect. Flashing operation can aid operators with colour blindness.



Scan QR Code to make an enquiry

## Earth-Rite® DGS Ex d Technical Specification

Ex d (Zone 1 Gas / Vapour Installations)

### Power Supply & Monitoring Unit

Power Supply	90 V to 265 V AC, 50-60 Hz
Power Rating	10 watt
Ambient Temperature Range	-40°C to +50°C
Ingress Protection	IP66
Weight	7 kgs (15.43 lbs) net
Construction	Copper-free cast aluminium
Monitoring Circuit	Intrinsically safe "ia"
Monitoring Loop Resistance	Nominally $\leq 10 \Omega$ per channel
Output Relay Contact Rating	3 off volt-free/dry change-over contacts 250 V AC, 5 A, 500 VA max resistive 30 V DC, 2 A, 60 W max resistive
Cable Entries	7 x M20 (1 x plugged) 4 in the West Face (Ex) 3 in the South Face (NonEx)

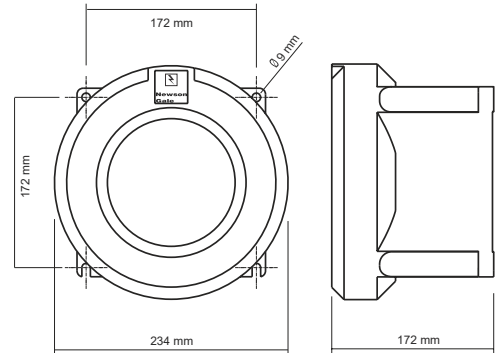

### 2 Junction Box complete with Stowage Point

Enclosure Material	Static dissipative carbon loaded GRP
Terminals	2 x 2.5 mm <sup>2</sup> conductor capacity
Stowage Device	Insulated universal stowage pin
Cable Entries	1 x M20 x 1.5
Clamp Cable Connection	Quick Connect

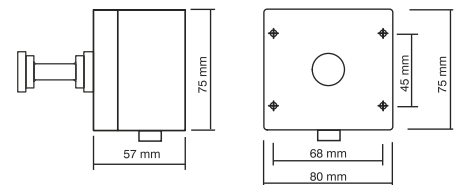

Simple Apparatus  
GRP junction box with nylon grounding clamp stowage pin

### Grounding Clamp

Clamp Design	Dual core with tungsten carbide teeth
Body	Stainless Steel
ATEX / FM / IECEx / UKEX Certification:	ATEX II 1 GD T6 (Assessed to EN 13463-1 : 2009) Ta = -40°C to +60°C Sira 02ATEX9381 ATEX Notified Body: SIRA
IECEX Ex h IIC T6 Ga Ex h IIIC T85°C Da Ta = -40°C to +60°C IECEX EXV 20.0033 IECEX Certified Body: ExVeritas	FM Certificate of Compliance number: 3046346
	UKCA Ex II 1 G II 1 D Ex h IIC T6 Ga Ex h IIIC T85°C Da Ta = -40°C to +60°C ExVeritas 21UKEX0842 UKCA Ex Approved Body: ExVeritas

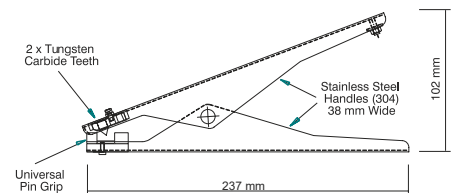



Static Grounding Clamp  
Dual core stainless steel grounding clamp fitted with one pair of tungsten carbide tips

### Spiral Cable

Cable	Dual core Cen-Stat blue spiral cable with Hytrel coating which has UV and static dissipative additives
Conductors	2 x 1.00 mm <sup>2</sup> copper
Length	3 m (10 ft), 5 m (16 ft), 10 m (32 ft) or 15 m (50 ft)

## Earth-Rite® DGS Ex d Hazardous Area Certification

Europe/International		North America Version Available	
IECEX	Ex db [ia Ga] IIC T6 Gb Ex tb [ia Da] IIIC T135°C Db Ta = -40°C to +50°C IECEX EXV 19.0069 IECEX Certifying Body: ExVeritas		Class I, Div. 1, Groups A, B, C and D, T6 Class II, Div. 1, Groups E, F, G, T135°C Class III, Div. 1, 135°C Associated Equipment for Class I, Div. 1, Groups A, B, C & D Class II, Div. 1, Groups E, F, G Class III, Div. 1 Ex db [ia Ga] IIC T6 Gb Ex tb [ia Da] IIIC T135°C Db Ta = -40°F to +122°F (-40°C to +50°C) Enclosure type: 4X, IP66 OSHA recognised NRTL: CSA Group
ATEX	 II 2(1)G II 2(1)D Ex db [ia Ga] IIC T6 Gb Ex tb [ia Da] IIIC T135°C Db Ta = -40°C to +50°C ExVeritas 19ATEX0564 ATEX Notified Body: ExVeritas	NEC 500 / CEC (Class & Division)	
UKCA Ex	 II 2(1)G II 2(1)D Ex db [ia Ga] IIC T6 Gb Ex tb [ia Da] IIIC T135°C Db Ta = -40°C to +50°C ExVeritas 21UKEX0841 UKCA Ex Approved Body: ExVeritas	NEC 505 & 506 (Class & Zoning)	Class I, Zone 1, AEx db [ia Ga] IIC T6 Gb Zone 21, AEx tb [ia Da] IIIC T135°C Db Ambient Temperature Range Ta = -40°F to +122°F (-40°C to +50°C) Enclosure type: 4X, IP66
CCC	Ex db [ia Ga] IIC T6 Gb Ex tb [ia Da] IIIC T135°C Db Ta = -40°C to +50°C 2021312309000482 Approved Body: CNEC		
KCS (Gas)	Ex db [ia Ga] IIC T6 Gb Ta = -40°C to +50°C 22-AV4BO-0348X Approved Body: KOSHA		
KCS (Dust)	Ex tb [ia Da] IIIC T135°C IP66 Db Ta = -40°C to +50°C 22-AV4BO-0349X Approved Body: KOSHA		
		<b>Additional Certification</b>	
		EMC Tested	to EN 61000-6-3, EN 61000-6-2 FCC - Part 15 (Class A)

# Earth-Rite® II FIBC

The **Earth-Rite® II FIBC** is a grounding system for Type C bags that are manufactured in accordance with IEC 61340-4-4. It consists of a grounding system and a pair of grounding clamps.

The **Earth-Rite® II FIBC** system supports safe handling of Type C FIBC bags by continuously monitoring and validating their grounding, preventing dangerous electrostatic discharges in flammable environments.



### The Earth-Rite® II FIBC includes:

- Static dissipative GRP enclosure with intrinsically safe monitoring circuits.
- FIBC grounding clamp with single conductor Hytrel® protected cable.
- Junction box with stowage pin for stowing FIBC monitoring clamp.



## KEY FEATURES

### Continuous Ground Loop Monitoring

- This circuit establishes a ground monitoring resistance loop so that when this loop resistance reading is within its threshold, the grounding system will go permissive. When the permissive condition is met the ground status indicators switch from red to flashing green.

### Loading Operation

- Varying cable lengths are available to attach the clamp to the Type C FIBC bag.

### Volt-Free/Dry Contacts

- Earth-Rite system output contacts can be interlocked with process equipment and/or strobes. Interlocking the grounding system with the process equipment can enhance the Standard Operating Procedures (SOP) before the movement of material can take place.

### Wide Ex Installation Compatibility

- Can be installed in all gas groups (IIA, IIB, IIC) and all dust groups (IIIA, IIIB, IIIC).

### IEC Compliance for Ex Areas

- Grounding clamps do not contain any insulating materials (rubber/plastic) that exceed the volume or surface area for Ex areas as specified in IEC TS 60079-32-1.

### Flexible Cable Options

- Available with static dissipative cable in spiral format.

# Earth-Rite® II FIBC

Newson Gale's dedicated Type C FIBC static grounding system.

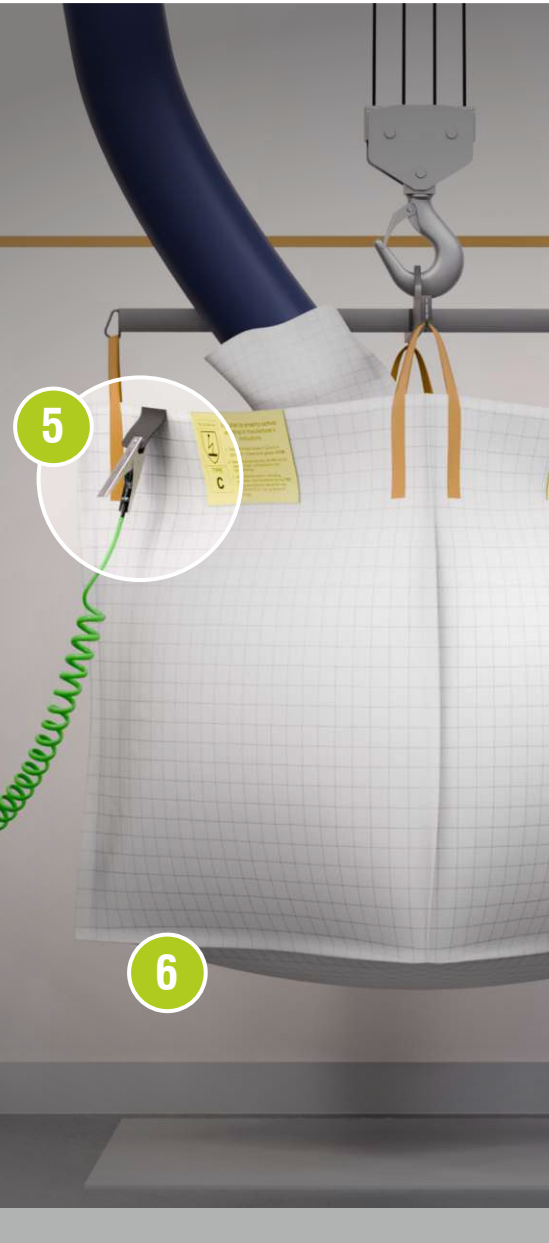

## 1

### Clear "GO/NO-GO" Indication

One solid red and three flashing green LEDs provide easy to understand "GO" or "NO-GO" indication to operators. Positive ground connection indicated via high intensity green flashing LEDs for their attention-grabbing effect. Flashing operation can aid operators with colour blindness.

## 2

### Two Enclosure Options

Static dissipative GRP enclosure for Ex dust environments (cast aluminium Ex d enclosure is also available).

## 3

### Interlocks

Two pairs of NO/NC volt-free contacts, optional one x intrinsically safe output contact.

Can be interlocked with automated bag filling/emptying systems or any other control equipment.

## 4

### Clamp Stowage Point

Enables operators to stow the clamp and cable when the grounding system is not in use.



IECEX



SIL 2

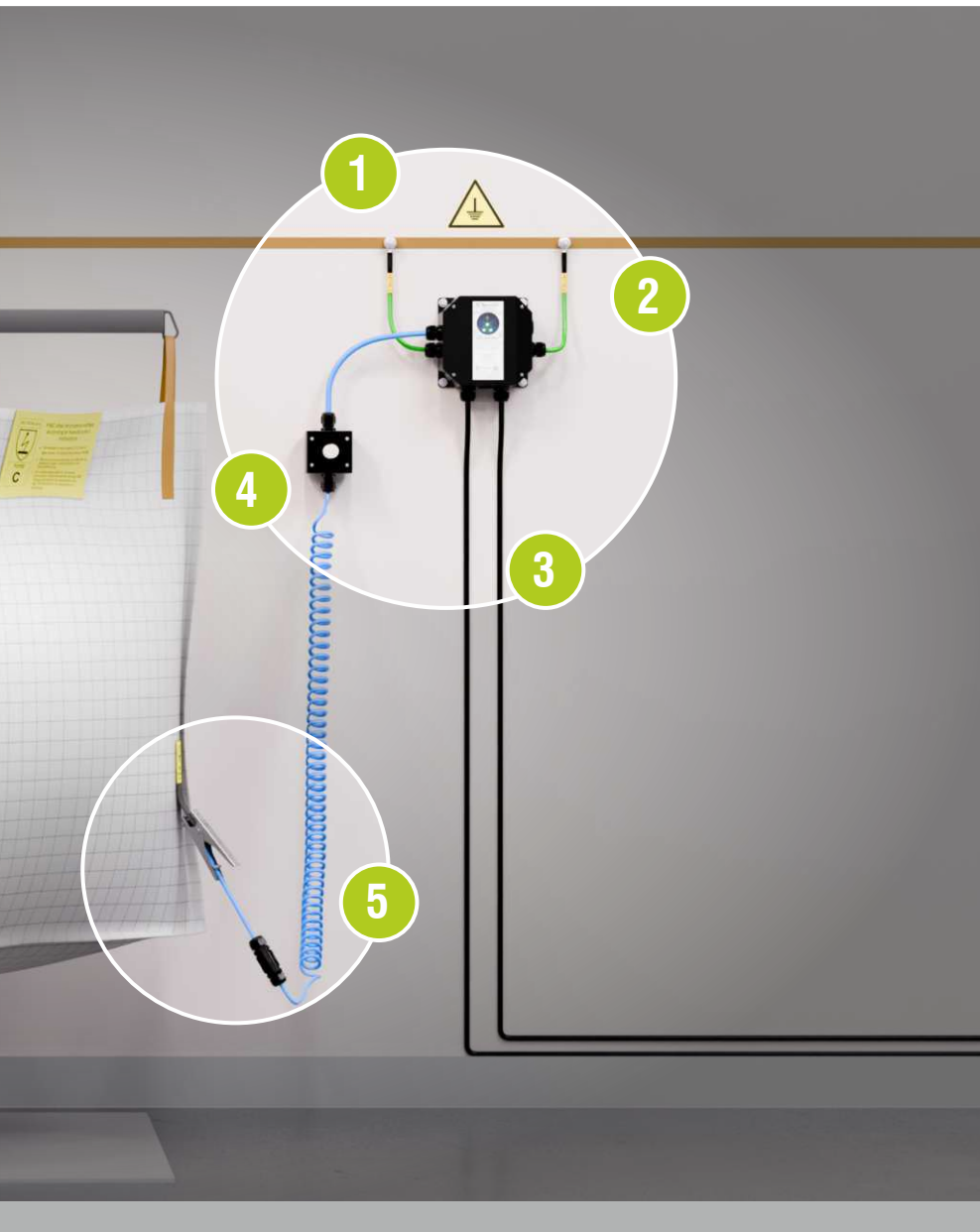

# 7

## Active Ground Loop Monitoring Circuit

Checks the resistance ( $R \leq 1 \times 10^9 \Omega$ ) of the conductive or static dissipative elements of the bag specified in BS EN IEC 61340-4-4 "Electrostatic classification of flexible intermediate bulk containers (FIBC)".

A version is available that tests  $R \leq 1 \times 10^7 \Omega$  bags if required.

Monitors the resistance through the Type C bag to the static ground point for the duration of the bag filling/emptying procedure.

# 5

## Two Clamps

Attaching the clamps on the top and bottom tabs of the bag monitors the resistance of the conductive thread/s or filaments between them and the ground point.

Provides operators with the solution of not needing to use the bag's lifting hooks as a fortuitous static dissipation path (which is prohibited by BS EN IEC 61340-4-4).

# 6

## "ia" Intrinsically Safe (IS) Circuits

Provides site operators with the highest level of IS protection suitable for use in "Da" and "Ga" environments which permits the positioning of the grounding clamps in Zones 20 or 0.



Scan QR Code  
to make an enquiry

## Earth-Rite® II FIBC GRP Technical Specification

GRP (Zone 2 Gas / Vapour Atmospheres - Zone 21 & 22 Dust Atmospheres)

### Power Supply & Monitoring Unit

Power Supply	115 V or 230 V AC, 50-60 Hz 12 V or 24 V DC
Power Rating	10 watt
Ambient Temperature Range	-40°C to +55°C
Ingress Protection	IP66
Weight	1.5 kg (3.3 lbs) net
Construction	Static dissipative carbon loaded GRP
Monitoring Circuit	Intrinsically safe "ia"
Operational Monitoring Resistance of Bag	Nominally $\leq 1 \times 10^6$ or $1 \times 10^7 \Omega$
Output Relay Contact Rating	2 off volt-free/dry change-over contacts 250 V AC, 5 A, 500 VA max resistive, 30 V DC, 2 A, 60 W max resistive
Cable Entries	7 x M20 (2 x plugged)

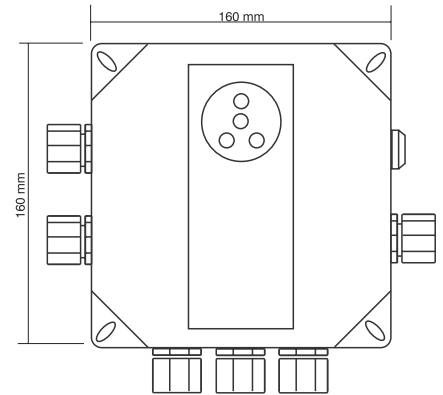

### Junction Box/Stowage Point

Enclosure Material	Static dissipative carbon loaded GRP
Terminals	2 x 2.5 mm <sup>2</sup> conductor capacity
Stowage Device	Insulated universal stowage pin
Cable Entries	1 x 20 mm
Clamp Cable Connection	Quick Connect

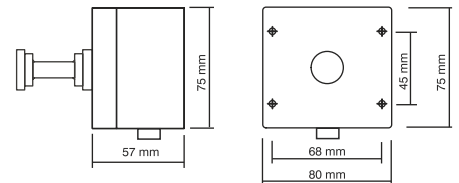

Simple Apparatus  
GRP junction box with nylon grounding clamp stowage pin

### Grounding & Monitoring Clamp

Monitoring Clamp Design	Stainless steel (SS grade: 304) clamp with rounded tip and serrated nylon wedge
Grounding Clamp Design	Stainless steel (SS grade: 304) clamp with rounded tip and serrated stainless steel wedge
ATEX / IECEx / UKEX Certification:	ATEX II 1 GD T6 (Assessed to EN 13463-1 : 2009) Ta = -40°C to +60°C Sira 02ATEX9381 ATEX Notified Body: SIRA
UKCA Ex II 1 G II 1 D Ex h IIC T6 Ga Ex h IIIC T85°C Da Ta = -40°C to +60°C ExVeritas 21UKEX0842 UKCA Ex Approved Body: ExVeritas	IECEX Ex h IIC T6 Ga Ex h IIIC T85°C Da Ta = -40°C to +60°C IECEX EXV 20.0033 IECEX Certified Body: ExVeritas

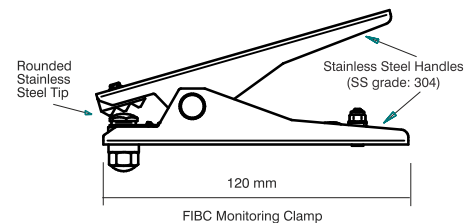

FIBC Monitoring Clamp

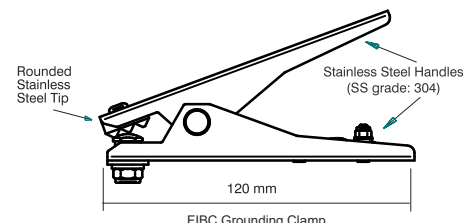



FIBC Grounding Clamp

### Spiral Cable

Monitoring Cable	Cen-Stat blue spiral cable with Hytrel coating which has UV and static dissipative additives
Monitoring Cable Length	5 m (16 ft) or 10 m (32 ft)
Grounding Cable	Cen-Stat green spiral cable with Hytrel coating which has UV and static dissipative additives
Grounding Cable Length	3m (10 ft), 5 m (16 ft) or 10 m (32 ft)
Conductors	1 x 4.00 mm <sup>2</sup> steel

## Earth-Rite® II FIBC GRP Hazardous Area Certification

### Europe/International

IECEX	Ex ec nC [ia Ga] IIC T4 Gc Ex tb [ia Da] IIIC T70°C Db Ta = -40°C to +55°C IECEX EXV 19.0059X IECEX Certifying Body: ExVeritas
ATEX	 II 3(1)G II 2(1)D Ex ec nC [ia Ga] IIC T4 Gc Ex tb [ia Da] IIIC T70°C Db Ta = -40°C to +55°C ExVeritas 19ATEX0545X ATEX Notified Body: ExVeritas
UKCA Ex	 II 3(1)G II 2(1)D Ex ec nC [ia Ga] IIC T4 Gc Ex tb [ia Da] IIIC T70°C Db Ta = -40°C to +55°C ExVeritas 21UKEX0833X UKCA Ex Approved Body: ExVeritas
CCC	Ex ec [ia Ga] nC IIC T4 Gc Ex tb [ia Da] IIIC T70°C Db Ta = -40°C to +55°C 2021312304001041 Approved Body: CNEX
KCS (Gas)	Ex ec nC [ia Ga] IIC T4 Gc(Ga) Ta = -40°C to +55°C 22-AV4BO-0319X Approved Body: KOSHA
KCS (Dust)	Ex tb IIIC T70°C Db Ta = -40°C to +55°C 22-AV4BO-0320X Approved Body: KOSHA

### North America Version Available

NEC 500 / CEC (Class & Division)	Associated Equipment [Ex ia] for use in Class I, Div. 2, Groups A, B, C, D Class II, Div. 2, Groups E, F, G Class III, Div. 2 Providing Intrinsically Safe circuits for Class I, Div. 1, Groups A, B, C, D Class II, Div. 1, Groups E, F, G Class III, Div. 1 Temperature Code T4 Ta = -13°F to +131°F (-25°C to +55°C) OSHA recognised NRTL: CSA
NEC 505 & 506 (Class & Zoning)	Class I, Zone 2, (Zone 0), AEx nA[ia] IIC T4 Class II, Zone 21, AEx tD[iaD] 21, T70°C
CEC Section 18 (Class & Zoning)	Class I, Zone 2 (Zone 0) Ex nA[ia] IIC T4 DIP A21, IP66, T70°C

### Additional Certification

Safety Integrity Level	SIL 2 (in accordance with IEC/EN 61508)
EMC Tested	To EN 61000-6-3, EN 61000-6-2 FCC - Part 15 (Class B)

## Earth-Rite® II FIBC Ex d Technical Specification

Ex d (Zone 1 Gas / Vapour Atmospheres - Zone 21 Dust Atmospheres)

### Power Supply & Monitoring Unit

Power Supply	115 V or 230 V AC, 50-60 Hz 12 V or 24 V DC
Power Rating	10 watt
Ambient Temperature Range	-40°C to +55°C
Ingress Protection	IP66
Weight	4.5 kgs (9.9 lbs) net
Construction	Copper-free cast aluminium
Monitoring Circuit	Intrinsically safe "ia"
Operational Monitoring Resistance of Bag	Nominally $\leq 1 \times 10^8$ or $1 \times 10^7 \Omega$
Output Relay Contact Rating	2 off volt-free/dry change-over contacts 250 V AC, 5 A, 500 VA max resistive 30 V DC, 2 A, 60 W max resistive
Cable Entries	7 x M20 (2 x plugged)

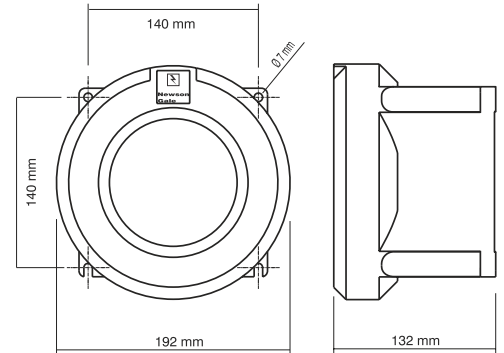

### Junction Box/Stowage Point

Enclosure Material	Static dissipative carbon loaded GRP
Terminals	2 x 2.5 mm <sup>2</sup> conductor capacity
Stowage Device	Insulated universal stowage pin
Cable Entries	1 x 20 mm
Clamp Cable Connection	Quick Connect

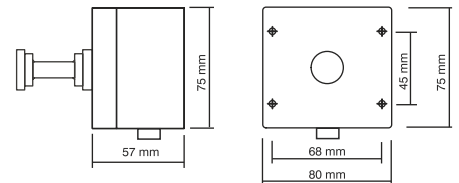

Simple Apparatus  
GRP junction box with nylon grounding clamp stowage pin

### Grounding & Monitoring Clamp

Monitoring Clamp Design	Stainless steel (SS grade: 304) clamp with rounded tip and serrated nylon wedge
Grounding Clamp Design	Stainless steel (SS grade: 304) clamp with rounded tip and serrated stainless steel wedge
ATEX / IECEx / UKEX Certification:	ATEX II 1 GD T6 (Assessed to EN 13463-1 : 2009) Ta = -40°C to +60°C Sira 02ATEX9381 ATEX Notified Body: SIRA
UKCA Ex II 1 G II 1 D Ex h IIC T6 Ga Ex h IIIC T85°C Da Ta = -40°C to +60°C ExVeritas 21UKEX0842 UKCA Ex Approved Body: ExVeritas	IECEX Ex h IIC T6 Ga Ex h IIIC T85°C Da Ta = -40°C to +60°C IECEX EXV 20.0033 IECEX Certified Body: ExVeritas

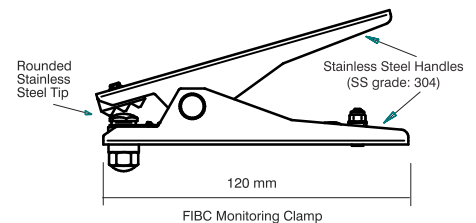

FIBC Monitoring Clamp

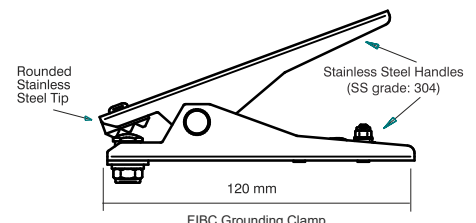



FIBC Grounding Clamp

### Spiral Cable

Monitoring Cable	Cen-Stat blue spiral cable with Hytrel coating which has UV and static dissipative additives
Monitoring Cable Length	5 m (16 ft) or 10 m (32 ft)
Grounding Cable	Cen-Stat green spiral cable with Hytrel coating which has UV and static dissipative additives
Grounding Cable Length	3m (10 ft), 5 m (16 ft) or 10 m (32 ft)
Conductors	1 x 4.00 mm <sup>2</sup> steel

## Earth-Rite® II FIBC Ex d Hazardous Area Certification

### Europe/International

IECEX	Ex db [ia Ga] IIC T6 Gb Ex tb [ia Da] IIIC T80°C Db Ta = -40°C to +55°C IECEX EXV 19.0052 IECEX Certifying Body: ExVeritas
ATEX	 II 2(1)G II 2(1)D Ex db [ia Ga] IIC T6 Gb Ex tb [ia Da] IIIC T80°C Db Ta = -40°C to +55°C ExVeritas 19ATEX0537 ATEX Notified Body: ExVeritas
UKCA Ex	 II 2(1)G II 2(1)D Ex db [ia Ga] IIC T6 Gb Ex tb [ia Da] IIIC T80°C Db Ta = -40°C to +55°C ExVeritas 21UKEX0832 UKCA Ex Approved Body: ExVeritas
CCC	Ex db [ia Ga] IIC T6 Gb Ex tb [ia Da] IIIC T80°C Db Ta = -40°C to +55°C 2021312304001040 Approved Body: CNEX
KCS (Gas)	Ex d [ia Ga] IIC T6 Gb(Ga) Ta = -40°C to +55°C 22-AV4BO-0334X Approved Body: KOSHA
KCS (Dust)	Ex tb IIIC T80°C IP66 Db Ta = -40°C to +55°C 22-AV4BO-0335X Approved Body: KOSHA

### North America Version Available

NEC 500 / CEC (Class & Division)	Associated Equipment [Ex ia] for use in Class I, Div. 1, Groups A, B, C, D Class II, Div. 1, Groups E, F, G Class III, Div. 1 Providing intrinsically safe circuits for Class I, Div. 1, Groups A, B, C, D Class II, Div. 1, Groups E, F, G Class III, Div. 1 Temperature Code T6 Ta = -40°F to +122°F (-25°C to +55°C) OSHA recognised NRTL: CSA.
NEC 505 & 506 (Class & Zoning)	Class I, Zone 1 [0] AEx d[ia] IIC T6 Gb(Ga) Class II, Zone 21 [20] AEx tD [iaD] 21 T80°C
CEC Section 18 (Class & Zoning)	Class I, Zone 1 [0] Ex d[ia] IIC T6 Gb(Ga) DIP A21, IP66, T80°C

### Additional Certification

Safety Integrity Level	SIL 2 (in accordance with IEC/EN 61508)
EMC Tested	to EN 61000-6-3, EN 61000-6-2 FCC - Part 15 (Class B)

# Bond-Rite® Range

**STAINLESS STEEL CLAMPS  
WITH VISUAL INDICATION**



**Bond-Rite® CLAMP**

Newson Gale's self-testing clamps with visual indication and monitoring.



**Bond-Rite® EZ**

Newson Gale's portable static bonding solution with visual indication.

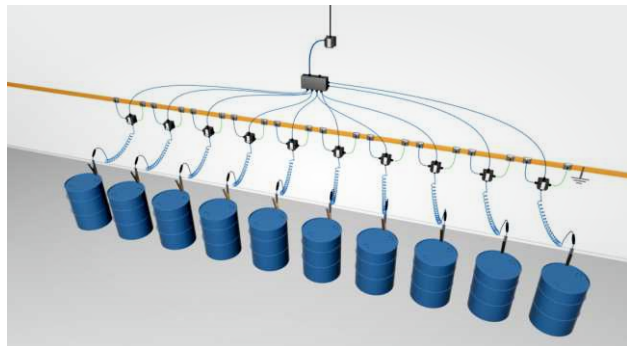

**Bond-Rite® REMOTE**

Newson Gale's continuous earth loop monitoring solution with visual indication.



# Bond-Rite® CLAMP

The **Bond-Rite® CLAMP** features a high intensity green LED that pulses continuously to indicate a secure ground connection. This occurs when the resistance between the equipment and the site's verified ground is 10 ohms or less.

The **Bond-Rite® CLAMP** is an ideal solution for applications and installations where interlocks with the process are not possible or required.



The **Bond-Rite® CLAMP** has a green flashing LED which provides process operators with a continuous visual reference point that enables them to monitor the ground status of conductive metal equipment capable of accumulating static electricity.

#### Typical Applications:

- Filling and dispensing metal containers, including drums, waste drums, and mixing vessels.
- Grounding equipment used in mixing and blending operations.



## KEY FEATURES

### Highly Visible LED

- The LED housed in the grounding clamp indicates to operators when a resistance threshold of 10 ohms or less has been achieved.

### Quick Connect

- The Quick Connect allows site personnel to carry out maintenance without the need of an electrical competent person being present.

### Battery Replacement

- Certification allows battery replacement in classified area.

*\*Always check the requirements of your certificate.*

### Stainless Steel Clamps

- Designed to withstand use in tough chemical processing and industrial environments.

### 10 Ohms Loop Resistance

- Monitoring based on National, International and Recommended Practices\*\*.

*\*\* Always check for and read the latest version of the International Standards and or Recommended Practices.*

### Tungsten Carbide Teeth

- The 'carbide' teeth are strong enough to penetrate through product deposit buildup, rust and drum coatings.

### Junction Box

- A mounted stowage pin provides operators with a location to return the clamp to when the process is complete.

*Note: If the process causes product deposits to impede the visibility of the LED indicator contact Newson Gale for alternative options.*

# Bond-Rite® CLAMP

Newson Gale's self-testing clamps with visual indication and monitoring.



## 1

### Battery Powered Clamp

The Bond-Rite® CLAMP is powered by an intrinsically safe 9V lithium-manganese battery. The typical battery lifetime is 6 months if used for 6 hours per day. The Ex certificate of the Bond-Rite® CLAMP permits changing of the battery in the hazardous area if required.\*

*\* In order to maintain the Ex certificate it is essential that the battery is replaced with the intrinsically safe model specified in the Instruction Manual supplied with the Bond-Rite® CLAMP. You must refer to your country's Ex certificate requirements.*

## 2

### Stainless Steel Clamp Body

The monitoring circuit and a flashing green LED are housed in a stainless steel clamp body that consists of a high strength torsion spring and a pair of tungsten carbide teeth designed to bite through layers of rust, paints and product deposits that could impede the transfer of electrostatic charges.

## 3

### Clear "GO/NO-GO" Indication

Operators are provided with a simple "GO/NO-GO" method of indication via a high intensity, flashing green LED housed in the lid of the Bond-Rite® CLAMP. The operators do not need to be trained to use Ex multi-meters which can be complex and costly.

## 4

### Installation Flexibility

The Ex certification permits the use of the Bond-Rite® CLAMP in all gas groups (IIA, IIB and IIC) and all dust groups (IIIA, IIIB and IIIC) due to its intrinsically safe Ex ia design.



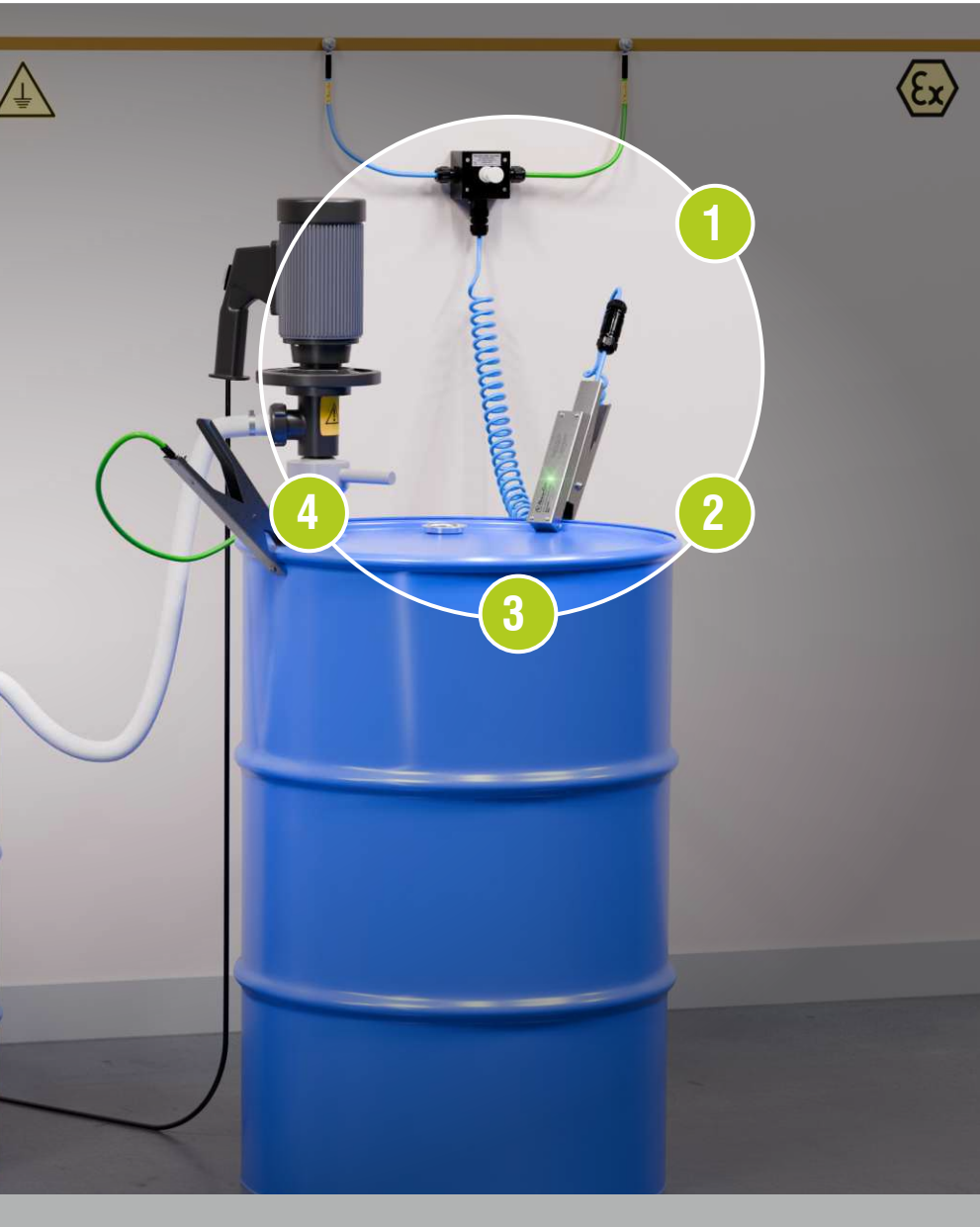

## 5

### GRP Junction Box

The junction box provides the operator with a dedicated storage point to store the clamp when not in use, which also promotes good housekeeping.

## 6

### Continuous Monitoring

The Bond-Rite® monitors the resistance between the clamp teeth back to the ground bar to 10 ohms or less and cannot be adjusted by operators.

**DOES NOT** require calibration at installation or throughout its lifecycle.



Scan QR Code  
to make an enquiry



**Bond-Rite® CLAMP** Technical Specification

Ingress Protection	IP64
Ambient Temperature Range	-40°C to +60°C
Monitoring Loop Resistance	Nominally $\leq 10 \Omega$
Indicator Lamp LED	1 Green
Clamp Dimensions	Length: 237mm Width: 34 mm
Weight	0.9 kgs



## Hazardous Area Certification

**Europe/International**

IECEX	Ex ia IIC T4 Ga Ex ia IIIC T135°C Da Ta = -40°C to +60°C IECEX EXV 19.0058 IECEX Certifying Body: ExVeritas
ATEX	 II 1 G II 1 D Ex ia IIC T4 Ga Ex ia IIIC T135°C Da Ta = -40°C to +60°C ExVeritas 19ATEX0543 ATEX Notified Body: ExVeritas
UKCA Ex	 II 1 G II 1 D Ex ia IIC T4 Ga Ex ia IIIC T135°C Da Ta = -40°C to +60°C ExVeritas 21UKEX0834 UKCA Ex Approved Body: ExVeritas
CCC	Ex ia IIC T4 Ga Ex iaD 20 T135°C Ta = -40°C to +60°C 2021312309000480 Approved Body: CNEX
KCS (Gas)	Ex ia IIC T4 Ga Ta = -40°C to +60°C 22-AV4BO-0296X Approved Body: KOSHA
KCS (Dust)	Ex ia IIIC T135°C Da Ta = -40°C to +60°C 22-AV4BO-0297X Approved Body: KOSHA

**North America Version Available**

NEC 500 / CEC (Class & Division)	Intrinsically safe equipment Exia for use in: Class I, Div. 1, Groups A, B, C, D. Class II, Div. 1, Groups E, F, G. Class III, Div. 1. Temperature Code: T4 Ta = -40°F to +140°F (-40°C to +60°C) OSHA recognised NRTL: CSA
-------------------------------------	---



# Bond-Rite® EZ

The **Bond-Rite® EZ** is a flexible device that verifies the bond between two conductive metal objects at risk of static charge accumulation.

The **Bond-Rite® EZ** is an ideal solution that monitors the loop resistance between conductive metal objects of 10 ohms or less, based on International Standards and Recommended Practices.



The **Bond-Rite® EZ** with a green flashing LED provides process operators with a continuous visual reference point that enables them to monitor the ground status of conductive metal equipment capable of accumulating static electricity.

#### Typical Applications:

- Filling and dispensing metal containers, including drums, waste drums, and mixing vessels.
- Grounding equipment used in mixing and blending operations.

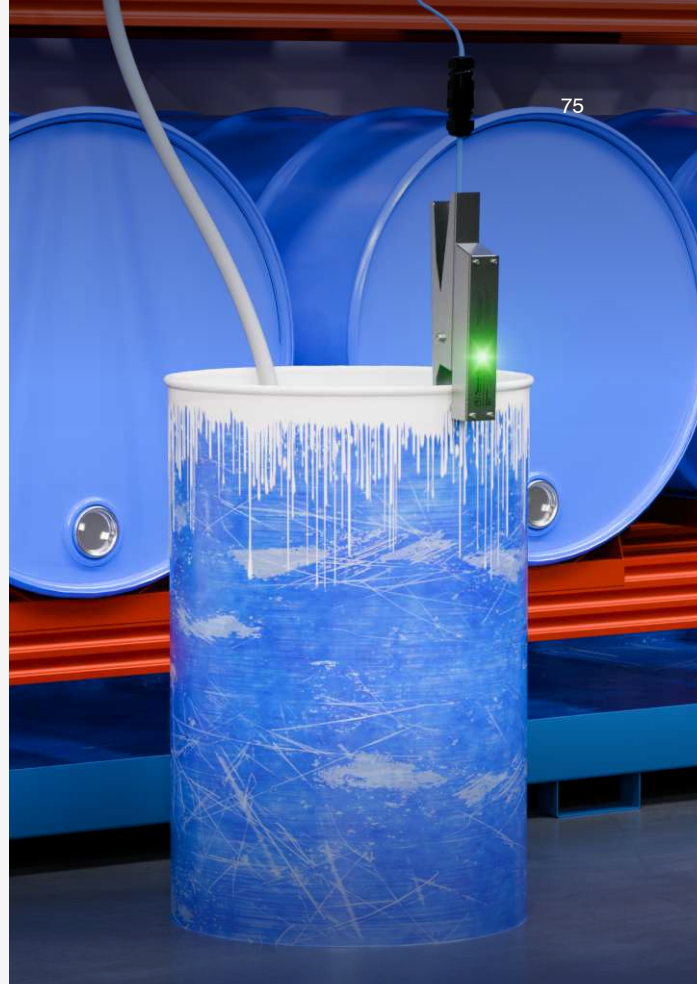

## KEY FEATURES

### Continuous Monitoring

- Monitors the loop resistance between conductive metal objects to 10 ohms or less based on International Standards and Recommended Practices.

### Stainless Steel Clamps

- Designed to withstand use in tough chemical processing and industrial environments, resistant to chemical attack and environmental corrosion.

### Tungsten Carbide Teeth

- For easy penetration through product deposit build up, rust and drum coatings to establish a 10 ohms or less connection to the conductive base metal.

### Quick Connect

- The Quick Connect allows site personnel to carry out maintenance without the need of an electrical competent person being present.

### Intrinsically Safe (IS) Circuit

- Certified intrinsically safe circuit permits the Bond-Rite® EZ to be used in the most hazardous gas, vapour and dust atmospheres.

### Battery Replacement

- Certification allows battery replacement in classified areas.

*\*Always check the requirements of your certificate.*

# Bond-Rite® EZ

Newson Gale's portable static bonding solution with visual indication.



## 1

### Battery Powered Clamp

The Bond-Rite® is powered by an intrinsically safe 9V lithium-manganese battery. The typical battery lifetime is 6 months if used for 6 hours per day. The Ex certificate of the Bond-Rite® permits changing of the battery in the hazardous area if required.\*

*\* In order to maintain the Ex certificate it is essential that the battery is replaced with the intrinsically safe model specified in the Instruction Manual supplied with the Bond-Rite®. You must refer to your country's Ex certificate requirements.*

## 2

### Stainless Steel Clamp Body

The monitoring circuit and a flashing green LED are housed in a stainless steel clamp body that consists of a high strength torsion spring and a pair of tungsten carbide teeth designed to bite through layers like rust, paints and product deposits that could impede the transfer of electrostatic charges.

## 3

### Clear "GO/NO-GO" Indication

Operators are provided with a simple "GO/NO-GO" method of indication via a high intensity, flashing green LED housed in the lid of the Bond-Rite®. The operators do not need to be trained to use Ex multi-meters which can be complex and costly.

## 4

### Heavy-Duty Grounding Clamp

Utilises a heavy-duty stainless steel clamp, that combines sharp tungsten carbide teeth with a strong torsion spring to establish, and maintain, a positive connection to the metal object (e.g., a drum) for the duration of the loading/unloading operation.



IECEX

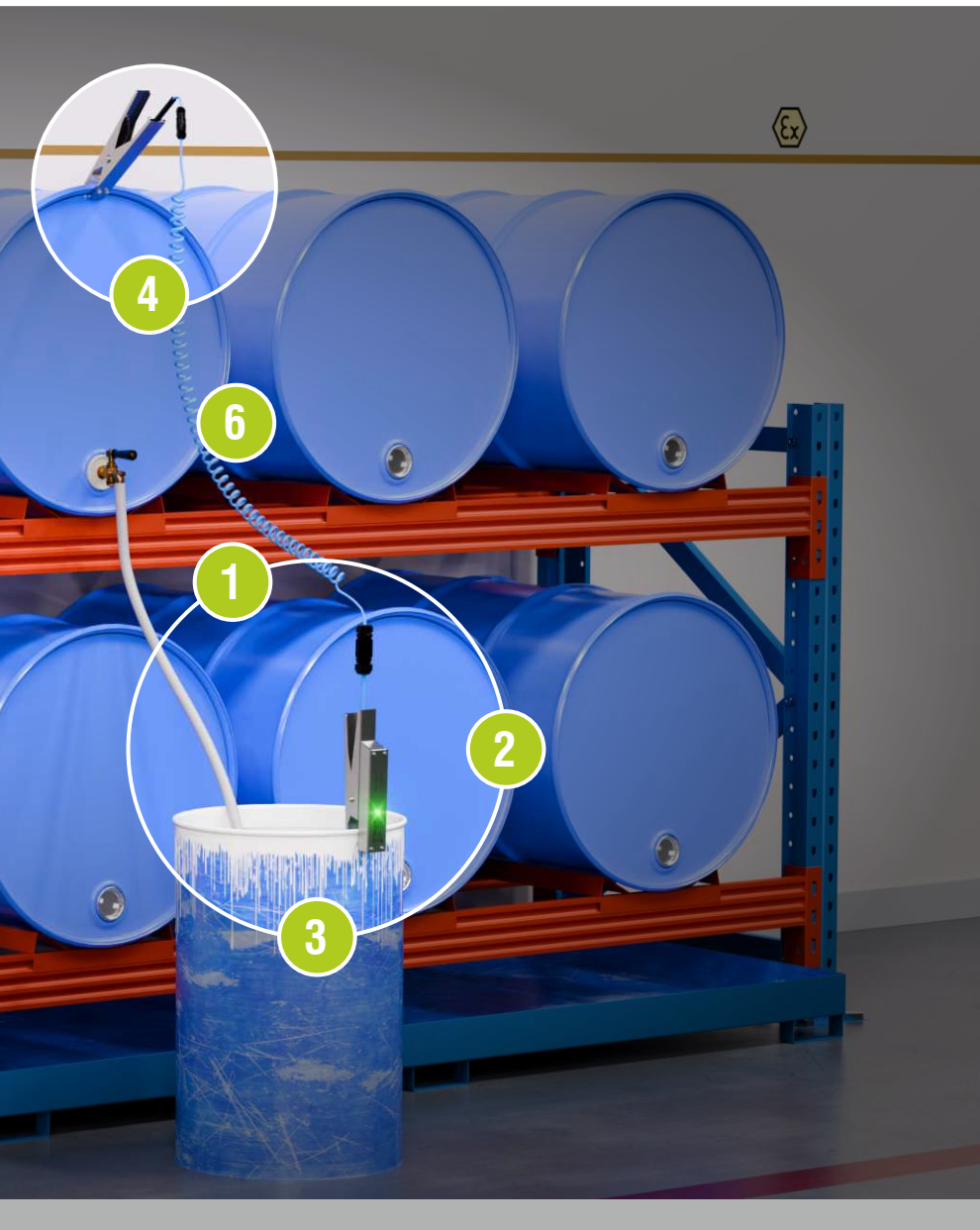

Grounding clamps **DO NOT** contain any insulating materials (rubber/plastic) that exceed the volume or surface area for Ex areas as specified in IEC TS 60079-32-1 (does not require rubber handle).

## 5

### Installation Flexibility

The Ex certification permits the use of the Bond-Rite® in the highest hazardous area zones (Zone 0/20), gas groups (IIA, IIB, IIC), and dust groups (IIIA, IIIB, IIIC) due to its intrinsically safe Ex ia design.

## 6

### Continuous Monitoring

The Bond-Rite® monitors the resistance between the clamp teeth back to the ground bar to 10 ohms or less and cannot be adjusted by operators.

**DOES NOT** require calibration at installation or throughout its lifecycle.





Scan QR Code  
to make an enquiry

**Bond-Rite® EZ Technical Specification**

Ingress Protection	IP64
Ambient Temperature Range	-40°C to +60°C
Monitoring Loop Resistance	Nominally $\leq 10 \Omega$
Indicator Lamp LED	1 Green
Clamp Dimensions	Length: 237mm Width: 34 mm

**Hazardous Area Certification****Europe/International**

IECEX	Ex ia IIC T4 Ga Ex ia IIIC T135°C Da Ta = -40°C to +60°C IECEX EXV 19.0058 IECEX Certifying Body: ExVeritas
ATEX	 II 1 G II 1 D Ex ia IIC T4 Ga Ex ia IIIC T135°C Da Ta = -40°C to +60°C ExVeritas 19ATEX0543 ATEX Notified Body: ExVeritas
UKCA Ex	 II 1 G II 1 D Ex ia IIC T4 Ga Ex ia IIIC T135°C Da Ta = -40°C to +60°C ExVeritas 21UKEX0834 UKCA Ex Approved Body: ExVeritas
CCC	Ex ia IIC T4 Ga Ex ia IIIC T135°C Da Ta = -40°C to +60°C 2021312309000480 Approved Body: CNEX
KCS (Gas)	Ex ia IIC T4 Ga Ta = -40°C to +60°C 22-AV4BO-0296X Approved Body: KOSHA
KCS (Dust)	Ex ia IIIC T135°C Da Ta = -40°C to +60°C 22-AV4BO-0297X Approved Body: KOSHA

**North America Version Available**

NEC 500 / CEC (Class & Division)	Intrinsically safe equipment Exia for use in: Class I, Div. 1, Groups A, B, C, D. Class II, Div. 1, Groups E, F, G. Class III, Div. 1. Temperature Code: T4 Ta = -40°F to +140°F (-40°C to +60°C) OSHA recognised NRTL: CSA
-------------------------------------	---



# Bond-Rite® REMOTE

The **Bond-Rite® REMOTE** flashing green LED provides process operators with a continuous visual reference point that enables them to monitor the ground status of conductive metal equipment capable of accumulating static electricity.

The **Bond-Rite® REMOTE** is an ideal solution for applications and installations where interlocks with the process are not possible or required.

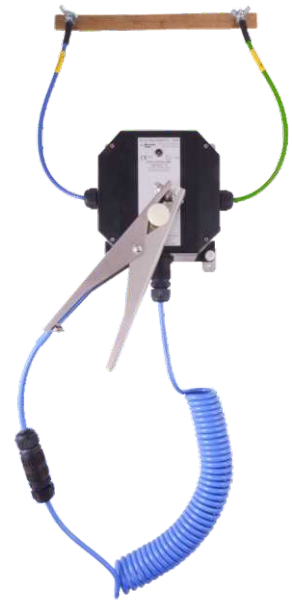

The **Bond-Rite® REMOTE** continuously monitors the loop resistance of the circuit between the equipment and the verified ground point (e.g., wall-mounted earth bar).

#### Typical Applications:

- Filling and dispensing metal containers, including drums, waste drums, and mixing vessels.
- Grounding equipment used in mixing and blending operations.



## KEY FEATURES

#### Power Options

- The Bond-Rite® REMOTE can be powered by either an intrinsically safe 9V battery (included) or an external 230/115 V AC power supply which can power up to 10 individual indicator stations.

#### Highly Visible LED

- The LED housed in the grounding clamp indicates to operators when a resistance threshold of 10 ohms or less has been achieved.

#### Continuous Monitoring

- Monitors the loop resistance between conductive metal objects of 10 ohms or less based on International Standards and Recommended Practices.

#### Stainless Steel Clamps

- Designed to withstand use in tough chemical processing and industrial environments, resistant to chemical attack and environmental corrosion.

#### Tungsten Carbide Teeth

- The 'carbide' teeth bite through product deposit buildup, rust and drum coatings to establish a 10 ohms or less connection to the conductive base metal.

#### Quick Connect

- The Quick Connect allows site personnel to carry out maintenance without the need of an electrical competent person being present.

#### Stowage Pin

- Indicator station mounted stowage pin provides operators with a location to return the grounding clamp.

#### Intrinsically Safe (IS) Circuit

- Certified intrinsically safe circuit permits the Bond-Rite® REMOTE to be used in the most hazardous gas, vapour and dust atmospheres.

#### Battery Replacement

- Certification allows battery replacement in classified areas.

*\*Always check the requirements of your certificate.*

# Bond-Rite® REMOTE

Newson Gale's continuous earth loop monitoring solution with visual indication.

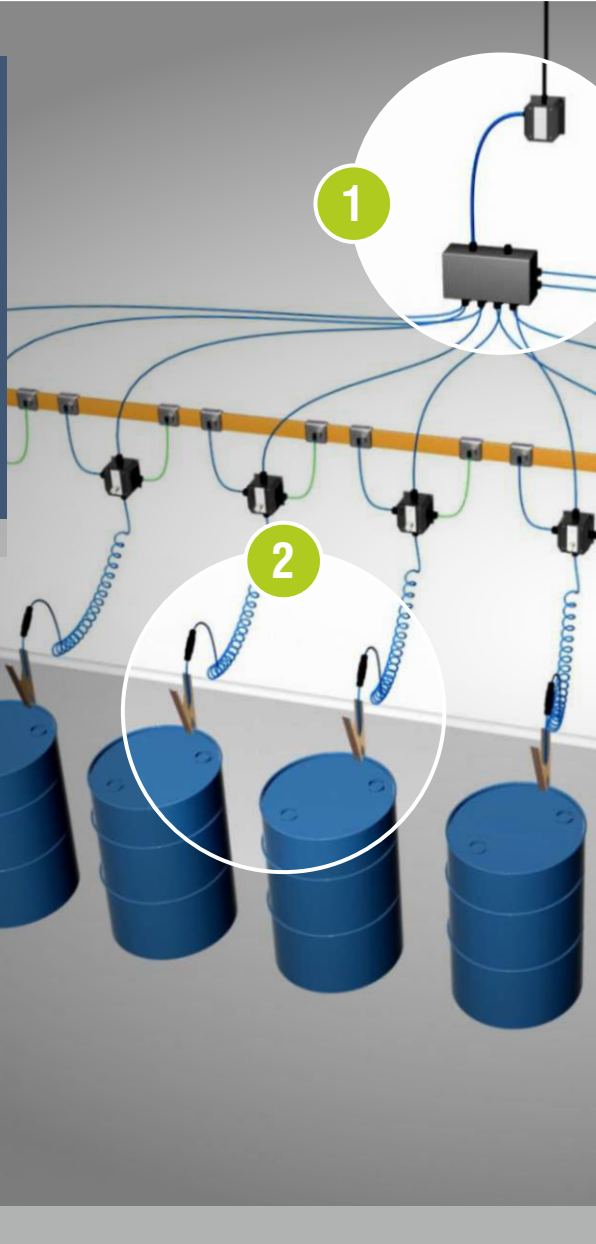

## 1

### Remote PSU and Marshalling Box

The remote power supply unit can be mounted in Zone 2/21 areas. Refer to technical specification for additional Ex certification details.

The marshalling box can be installed in Zone 0/20 and distribute power to up to 10 Bond-Rite® REMOTE units.

## 2

### Heavy-Duty Grounding Clamp

Utilises a heavy-duty stainless-steel clamp, that combines sharp tungsten carbide teeth with a strong torsion spring to establish, and maintain, a positive connection to the metal object (e.g., drums) for the duration of the loading/unloading operation.

## 3

### Continuous Monitoring

The Bond-Rite® monitors the resistance between the clamp teeth back to the ground bar to 10 ohms or less and cannot be adjusted by operators.

**DOES NOT** require calibration at installation or throughout its lifecycle.

## 4

### Clear “GO/NO-GO” Indication

Operators are provided with a simple “GO/NO-GO” indication via a highly visible flashing green LED located in the wall mounted enclosure. The operators do not need to be trained to use Ex multi-meters which can be complex and costly.



IECEX

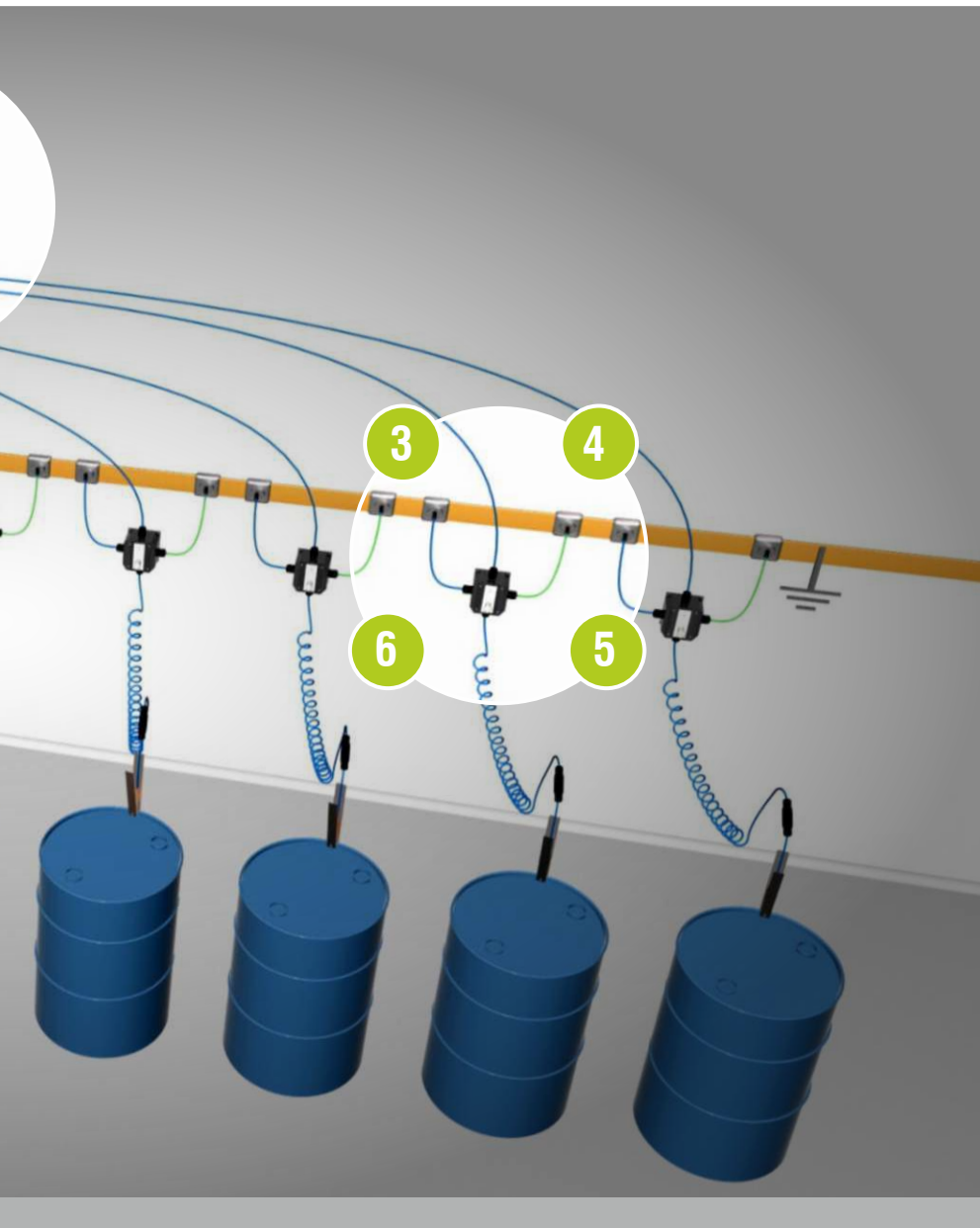

Grounding clamps **DO NOT** contain any insulating materials (rubber/plastic) that exceed the volume or surface area for Ex areas as specified in IEC TS 60079-32-1 (does not require rubber handle).

## 5

### Monitoring Circuit

The intrinsically safe monitoring circuit can be supplied in a GRP or stainless-steel enclosure that can be mounted on walls and gantries within the hazardous area.

## 6

### Installation Flexibility

The Ex certification permits the use of the Bond-Rite® REMOTE in the highest hazardous area zones (Zone 0/20), gas groups (IIA, IIB, IIC), and dust groups (IIIA, IIIB, IIIC) due to its intrinsically safe Ex ia design.



Scan QR Code  
to make an enquiry

## Bond-Rite® REMOTE GRP Technical Specification

### Bond-Rite® REMOTE [GRP] - Battery Powered and Mains Powered

Ingress Protection	IP66
Ambient Temperature Range	-40°C to +60°C
Monitoring Loop Resistance	Nominally $\leq 10 \Omega$
Indicator Lamp	LED: 1 Green
Battery Supply Option	Varta 6122 E-Block (9V Lithium-Manganese Battery) supplied with unit
Power Supply Option	Newson Gale Universal Power Supply
Enclosure Material	Glass Reinforced Plastic (carbon loaded)
Weight	1.1 kgs

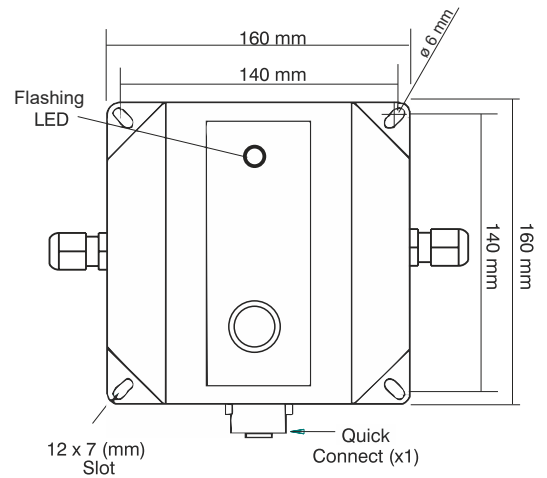

## Hazardous Area Certification

### Europe/International

IECEX	Ex ia IIC T4 Ga Ex ta IIIC T135°C Da Ta = -40°C to +60°C IECEX EXV 19.0061X IECEX Certifying Body: ExVeritas
ATEX	II 1 G II 1 D Ex ia IIC T4 Ga Ex ta IIIC T135°C Da Ta = -40°C to +60°C ExVeritas 19ATEX0547X ATEX Notified Body: ExVeritas
UKCA Ex	II 1 G II 1 D Ex ia IIC T4 Ga Ex ta IIIC T135°C Da Ta = -40°C to +60°C ExVeritas 21UKEX0835X UKCA Ex Approved Body: ExVeritas
CCC	Ex ia IIC T4 Ga Ex ta IIIC T135°C Da Ta = -40°C to +60°C 2021312304001043 Approved Body: CNEX
KCS (Gas)	Ex ia IIC T4 Ga Ta = -40°C to +60°C 22-AV4BO-0300X Approved Body: KOSHA
KCS (Dust)	Ex ta IIIC T135°C Da Ta = -40°C to +60°C 22-AV4BO-0301X Approved Body: KOSHA

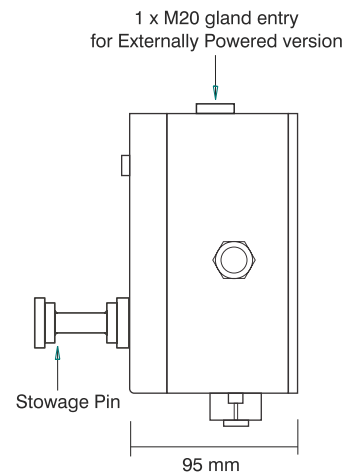

### North America Version Available

NEC 500 / CEC (Class & Division)	Intrinsically safe equipment Exia for use in: Class I, Div. 1, Groups A, B, C, D. Class II, Div. 1, Groups E, F, G. Class III, Div. 1. Temperature Code: T4 Ta = -40°F to +140°F (-40°C to +60°C) OSHA recognised NRTL: CSA
NEC 505 & 506 (Class & Zoning)	Class I, Zone 0, AEx ia IIC T4 Ga Class II, Zone 20, AEx iaD 20 T135°C
CEC Section 18 (Class & Zoning)	Class I, Zone 0 Ex ia IIC T4 Ga DIP A20, IP66, T135°C

## Bond-Rite® REMOTE Stainless Steel Technical Specification

### Bond-Rite REMOTE [Stainless Steel] - Battery Powered and Mains Powered

Ingress Protection	IP66
Ambient Temperature Range	-40°C to +60°C
Monitoring Loop Resistance	Nominally $\leq 10 \Omega$
Indicator Lamp	LED: 1 Green
Battery Supply Option	Varta 6122 E-Block (9V Lithium-Manganese Battery) supplied with unit
Power Supply Option	Newson Gale Universal Power Supply
Enclosure Material	Stainless steel (SS grade: 316L)
Weight	1.9 kgs

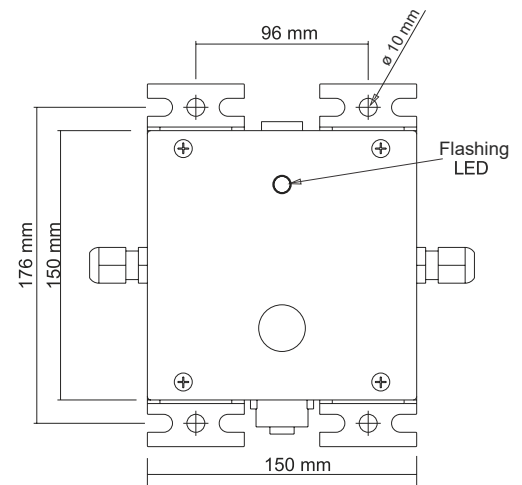

## Hazardous Area Certification

### Europe/International

IECEX	Ex ia IIC T4 Ga Ex ta IIIC T135°C Da Ta = -40°C to +60°C IECEX EXV 19.0061X IECEX Certifying Body: ExVeritas
ATEX	II 1 G II 1 D Ex ia IIC T4 Ga Ex ta IIIC T135°C Da Ta = -40°C to +60°C ExVeritas 19ATEX0547X ATEX Notified Body: ExVeritas
UKCA Ex	II 1 G II 1 D Ex ia IIC T4 Ga Ex ta IIIC T135°C Da Ta = -40°C to +60°C ExVeritas 21UKEX0835X UKCA Ex Approved Body: ExVeritas
CCC	Ex ia IIC T4 Ga Ex ta IIIC T135°C Da Ta = -40°C to +60°C 2021312304001043 Approved Body: CNEX
KCS (Gas)	Ex ia IIC T4 Ga Ta = -40°C to +60°C 22-AV4BO-0300X Approved Body: KOSHA
KCS (Dust)	Ex ta IIIC T135°C Da Ta = -40°C to +60°C 22-AV4BO-0301X Approved Body: KOSHA

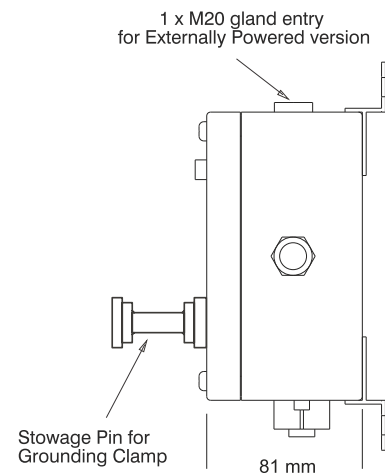

### North America Version Available

NEC 500 / CEC (Class & Division)	Intrinsically safe equipment Exia for use in: Class I, Div. 1, Groups A, B, C, D. Class II, Div. 1, Groups E, F, G. Class III, Div. 1. Temperature Code: T4 Ta = -40°F to +140°F (-40°C to +60°C) OSHA recognised NRTL: CSA
NEC 505 & 506 (Class & Zoning)	Class I, Zone 0, AEx ia IIC T4 Ga Class II, Zone 20, AEx iaD 20 T135°C
CEC Section 18 (Class & Zoning)	Class I, Zone 0 Ex ia IIC T4 Ga DIP A20, IP66, T135°C

## Bond-Rite® REMOTE Universal Power Supply Technical Specification

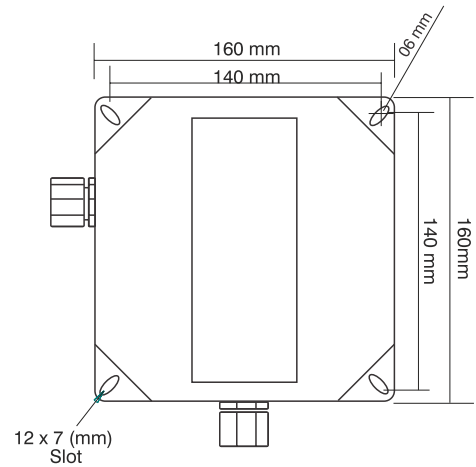

### Universal Power Supply Unit

Ingress Protection	IP66
Ambient Temperature Range	-40°C to +55°C
Monitoring Loop Resistance	Nominally ≤ 10 Ω
Power Supply Option	115 V or 230 V AC, 50-60 Hz
Enclosure Material	Glass Reinforced Plastic (carbon loaded)
Weight	1.25 kgs



### Hazardous Area Certification

#### Europe/International

IECEX	Ex ec [ia Ga] IIC T4 Gc Ex tb [ia Da] IIIC T70°C Db Ta = -40°C to +55°C IECEX EXV 19.0063 IECEX Certifying Body: ExVeritas
ATEX	 II 3(1)G II 2(1)D Ex ec [ia Ga] IIC T4 Gc Ex tb [ia Da] IIIC T70°C Db Ta = -40°C to +55°C ExVeritas 19ATEX0551 ATEX Notified Body: ExVeritas
UKCA Ex	 II 3(1)G II 2(1)D Ex ec [ia Ga] IIC T4 Gc Ex tb [ia Da] IIIC T70°C Db Ta = -40°C to +55°C ExVeritas 21UKEX0836 UKCA Ex Approved Body: ExVeritas
CCC	Ex ec [ia Ga] IIC T4 Gc Ex tb [ia Da] IIIC T70°C Db Ta = -40°C to +55°C 2021312303000497 Approved Body: CNEX
KCS (Gas)	Ex ec [ia] IIC T4 Gc(Ga) Ta = -40°C to +55°C 22-AV4BO-0302X Approved Body: KOSHA
KCS (Dust)	Ex tb IIIC T70°C Db IP66 Ta = -40°C to +55°C 22-AV4BO-0303X Approved Body: KOSHA
<b>Additional Certification</b>	
EMC Tested	to EN 61000-6-2, EN 61000-6-3 to FCC - Part 15

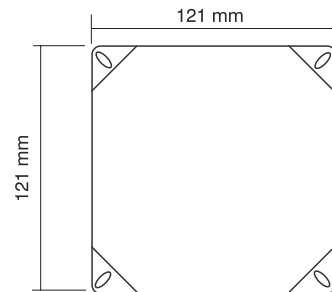

4 Entry Junction Box

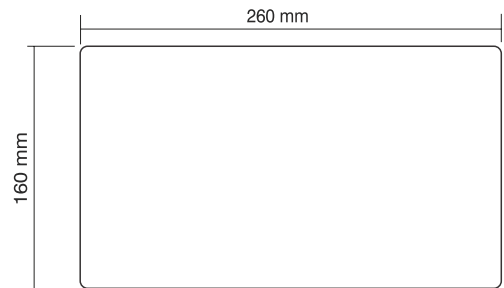

10 Entry Junction Box

#### North America Version Available

NEC 500 / CEC (Class & Division)	Associated Equipment [Exia] for use in: Class I, Div. 2, Groups A, B, C, D; Class II, Div. 2, Groups E, F, G; Class III, Div. 2. Providing Intrinsically safe circuits for: Class I, Div. 1, Groups A, B, C, D; Class II, Div 1, Groups E, F, G; Class III, Div 1. Temperature code: T4 Ta = -13°F to +131°F (-25°C to +55°C) OSHA recognised NRTL: CSA
	NEC 505 & 506 (Class & Zoning)
CEC Section 18 (Class & Zoning)	Class I, Zone 2 (Zone 0), Ex nA [ia] IIC T4 DIP A22 T70°C



Cen-Stat™

Newson Gale  
MEMBER OF SOLUTIONS

**PASSIVE STATIC GROUNDING  
CLAMPS, CABLES & REELS**



**Cen-Stat™ Clamps & Cables**

Static grounding clamps with Hytrel® coated spiral cable.



**Cen-Stat™ Cable Reels**

Retractable static dissipative cable reels.



**Personnel Grounding Strap**

Medium-duty stainless steel grounding clamp with wrist strap for operator charge dissipation.



# Cen-Stat™ Clamps & Cables

The **Cen-Stat™** range of ATEX and FM approved static grounding clamps and cable systems are designed to operate in the harshest Ex areas.

Cen-Stat™ is a range of brightly coloured cables specially designed for applications in industrial and hazardous areas. Cables are based upon Hytrel®, which combines the flexibility of rubber with the strength and process flexibility of thermoplastics.



IECEx



The certifications achieved by our range of clamps and cables benchmark their ability to establish and maintain good electrical contact with equipment requiring static grounding and bonding protection.

Option for equipment specifiers may select passive grounding devices, like single pole clamps, to earth and bond plant equipment.

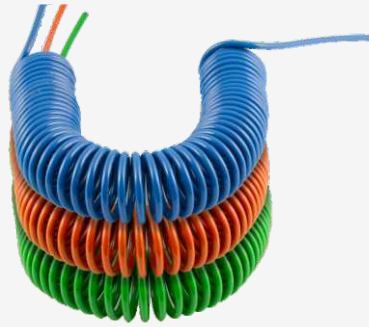

## KEY FEATURES

### Cen-Stat™ Clamps

- Stainless steel construction.
- Tungsten carbide teeth.
- Heavy-duty torsion spring.
- Ideal for grounding drums and containers.
- Option for medium or heavy-duty operations.

### Cen-Stat™ Cables

- Brightly coloured retractable cable.
- Hytrel® cables provide more flexibility and strength.
- Resistant to a wide range of chemicals.
- Formulated to include static dissipative material.
- Additional protection to ultraviolet (UV) light.

### ATEX/FM Certified

- Clamp pressure testing for ergonomic use.
- Electrical resistance, all tested to less than 10 ohms.
- 4 hour long continuous vibration test at varying frequency.
- Mechanical pull testing with objects ranging from 1-3mm.

# Cen-Stat™ Clamps & Cables

Cen-Stat™ static grounding clamps with Hytrel® coated cable.

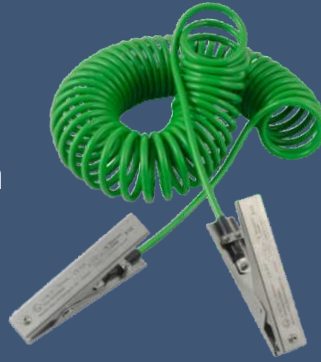

## 1

### Hytrel® Cables

Cen-Stat™ cables are based upon Hytrel® that combines the flexibility of rubber with the strength and process flexibility of thermoplastics. Hytrel® cables are mechanically resilient, with a wide working temperature and resistant to a wide range of chemicals.

Cen-Stat™ cables are supplied in standard retractable spiral lengths of 3 m (10 ft), 5 m (16 ft), and 10 m (32 ft). (Other lengths available).

## 2

### Galvanised Steel Core

The conductor is comprised of multi-stranded galvanised steel threads providing good mechanical strength with a conductor cross-sectional area of 4 mm<sup>2</sup> (11 AWG).

## 3

### Static Dissipative Material

Included in our Cen-Stat™ formulation is static dissipative material making it ideal for hazardous areas.

## 4

### Global Certification

UKCA, IECEx, ATEX and FM approved.



# 8

## FM Approved Clamps

**Clamp Pressure** – ensuring the grounding clamp is capable of establishing and maintaining low resistance electrical contact with equipment.

**Electrical Resistance** – ensuring the electrical continuity from the teeth throughout the grounding clamp is less than 1 ohm.

**Frequency Vibration** – ensures the grounding clamp is capable of maintaining positive contact when attached to vibrating equipment.

**Mechanical Pull Test** – ensures the grounding clamp cannot be pulled off the equipment.

# 7

## Tungsten Carbide Teeth

Tungsten carbide teeth are designed to penetrate through rust, coatings and product deposits to achieve good electrical contact.



Scan QR Code to make an enquiry



3

5

6

7

8

# 5

## Colour Coded Cables

**Green** - Passive grounding cable colour coded for Europe and the rest of the world.

**Orange** - Passive grounding cable colour coded for North and South America.

# 6



## UV Protection

Additives provide protection against exposure to ultraviolet (UV) light.

**Cen-Stat™ Technical Specification****VESX90 - Large size heavy-duty static grounding clamp with Cen-Stat™ cable**

Applications	Grounding and bonding metal objects ranging from 55 gallon drums to large metal totes and Ex IBCs
Clamp Material	Stainless Steel (SS grade: 304)
Operating Temperature	-40°C to +60°C
Dimensions	237 mm x 105 mm x 35 mm (9.33" x 4.13" x 1.38")
Maximum Jaw Opening	30 mm (1.18") approx.
Clamp Teeth	2 tungsten carbide teeth - set side by side in a stainless steel mounting block for extra stability
Spring	Torsion spring Stainless Steel (SS Grade: 302)
Cable	Cen-Stat spiral multi-stranded galvanized steel with green anti-UV / static dissipative Hytrel coating
Cable Length	3 m (10 ft), 5 m (16 ft) or 10 m (32 ft)
Cable Size	Conductor cross sectional area - 4 mm <sup>2</sup> (11 AWG) approx. with Cen-Stat coating - 6.5 mm (0.25") diameter
Clamp Weight	0.424 kgs (0.93 lbs)
Ring Terminal	10 mm (0.4") hole diameter (standard) Other sizes available on request



**ATEX / FM / IECEx / UKEX Clamp Certification**

ATEX	 II 1 GD T6 (Assessed to EN 13463-1 : 2009) Ta = -40°C to +60°C Sira 02ATEX9381 ATEX Notified Body: SIRA
FM	Certificate of Compliance number: 3046346
IECEx	Ex h IIC T6 Ga Ex h IIIC T85°C Da Ta = -40°C to +60°C IECEx EXV 20.0033 IECEx Certified Body: ExVeritas
UKCA Ex	 II 1 G II 1 D Ex h IIC T6 Ga Ex h IIIC T85°C Da Ta = -40°C to +60°C ExVeritas 21UKEX0842 UKCA Ex Approved Body: ExVeritas

**VESX45 - Medium size heavy-duty static grounding clamp with Cen-Stat™ cable**

Applications	Grounding and bonding metal objects ranging from 55 gallon drums to large metal totes and Ex IBCs
Clamp Material	Stainless Steel (SS grade: 304)
Operating Temperature	-40°C to +60°C
Dimensions	120 mm x 60 mm x 25 mm (4.72" x 2.36" x 0.98")
Maximum Jaw Opening	13 mm (0.51") approx.
Clamp Teeth	2 tungsten carbide teeth - set side by side in a stainless steel mounting block for extra stability
Spring	Torsion spring Stainless Steel (SS Grade: 302)
Cable	Cen-Stat spiral multi-stranded galvanized steel with green anti-UV / static dissipative Hytrel coating
Cable Length	3 m (10 ft), 5 m (16 ft) or 10 m (32 ft)
Cable Size	Conductor cross sectional area - 4 mm <sup>2</sup> (11 AWG) approx. with Cen-Stat™ coating - 6.5 mm (0.25") diameter
Clamp Weight	0.135 kgs (0.29 lbs)
Ring Terminal	10 mm (0.4") hole diameter (standard) Other sizes available on request

**ATEX / FM / IECEx / UKEX Clamp Certification**

ATEX	 II 1 GD T6 (Assessed to EN 13463-1 : 2009) Ta= -40°C to +60°C Sira 02ATEX9381 ATEX Notified Body: SIRA
FM	Certificate of Compliance number: 3031650
IECEx	Ex h IIC T6 Ga Ex h IIIC T85°C Da Ta = -40°C to +60°C IECEx EXV 20.0033 IECEx Certified Body: ExVeritas
UKCA Ex	 II 1 G II 1 D Ex h IIC T6 Ga Ex h IIIC T85°C Da Ta = -40°C to +60°C ExVeritas 21UKEX0842 UKCA Ex Approved Body: ExVeritas

# Cen-Stat™ Cable Reels

Newson Gale's self-retracting cable reels features Hytrel® coated cable, offering an alternative solution to Cen-Stat™ spiral cables.

Newson Gale's globally certified reels come in two versions: blue powder-coated reels and stainless steel variants designed for clean processes such as pharmaceuticals. Both types are supplied with Hytrel® coated stainless steel cable.



The certifications achieved by our range of clamps, cables and reels benchmark their ability to establish and maintain good electrical contact with equipment requiring static grounding and bonding protection.

Option for equipment specifiers may select passive grounding devices, like single pole clamps, to earth and bond plant equipment.



## KEY FEATURES

### Cen-Stat™ Cable Reels

- Ensures operators stow clamps away after use.
- Self-retracting cable housed in automatically retractable cable reel.
- Hand-operated reel option available.
- Ideal for grounding and bonding metal objects from small cans to large drums.
- A complete range of reels to mitigate electrostatic charge accumulation.
- Added weathering protection for the cable when retracted.
- Integrated clamp stowage on certain models.
- Alternative solution to retractable Cen-Stat™ spiral cable.

### Cen-Stat™ Cable

- Brightly coloured retractable cable.
- Hytrel® cables provide more flexibility and strength.
- Resistant to a wide range of chemicals.
- Formulated to include static dissipative material.
- Additional protection to ultraviolet (UV) light.

### ATEX/FM Certified

- Clamp pressure testing for ergonomic use.
- Electrical resistance, all tested to less than 10 ohms.
- 4 hour long continuous vibration test at varying frequency.
- Mechanical pull testing with objects ranging from 1-3mm.

# Cen-Stat™ Cable Reels

Newson Gale's range of static dissipative cable reels.



## 1

### Hytrel® Cables

The blue powder coated or stainless steel reels are supplied with a yellow coated Hytrel® cable. Hytrel® combines the flexibility of rubber with the strength and process flexibility of thermoplastics.

Cables made from Hytrel® are mechanically resilient, have a wide working temperature and are resistant to a wide range of chemicals, as well as being strong and durable.

## 2

### Retractable Cable

Self retracting cable reels ensure the grounding cable is stowed correctly to fully promote housekeeping duties, reduced trip hazards from a safety perspective, and to keep them protected when not in use.

## 3

### Latching Mechanism

The retractable cable reels feature a latching mechanism to ensure the cable is not under strain whilst in use.

## 4

### Stainless Steel Reel Option

Stainless steel variants are available for clean processes such as pharmaceuticals. The stainless steel reels are supplied with Hytrel® coated stainless steel cable.

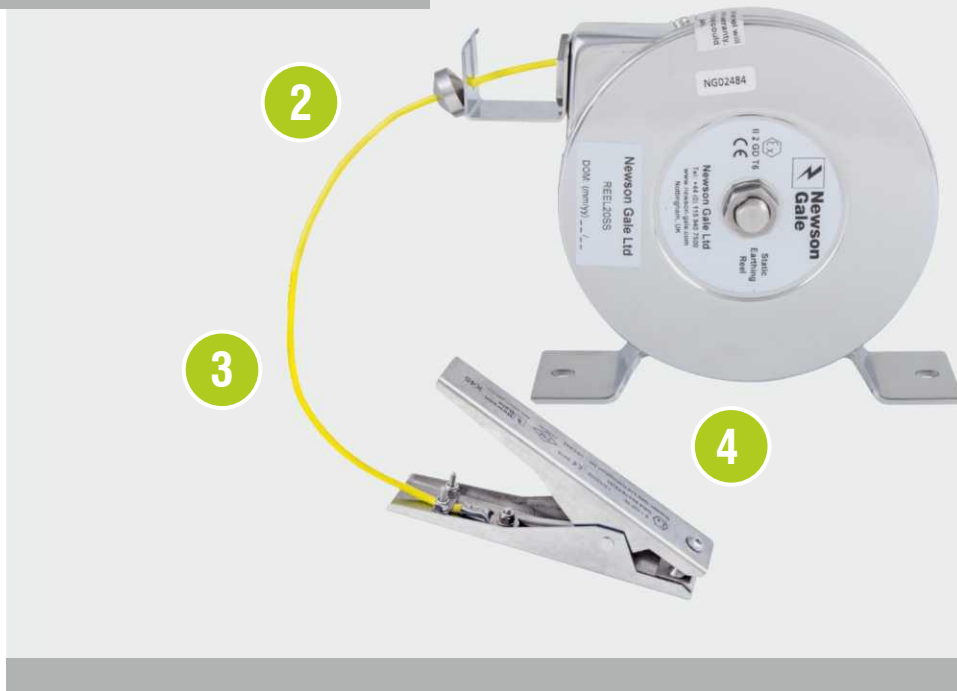

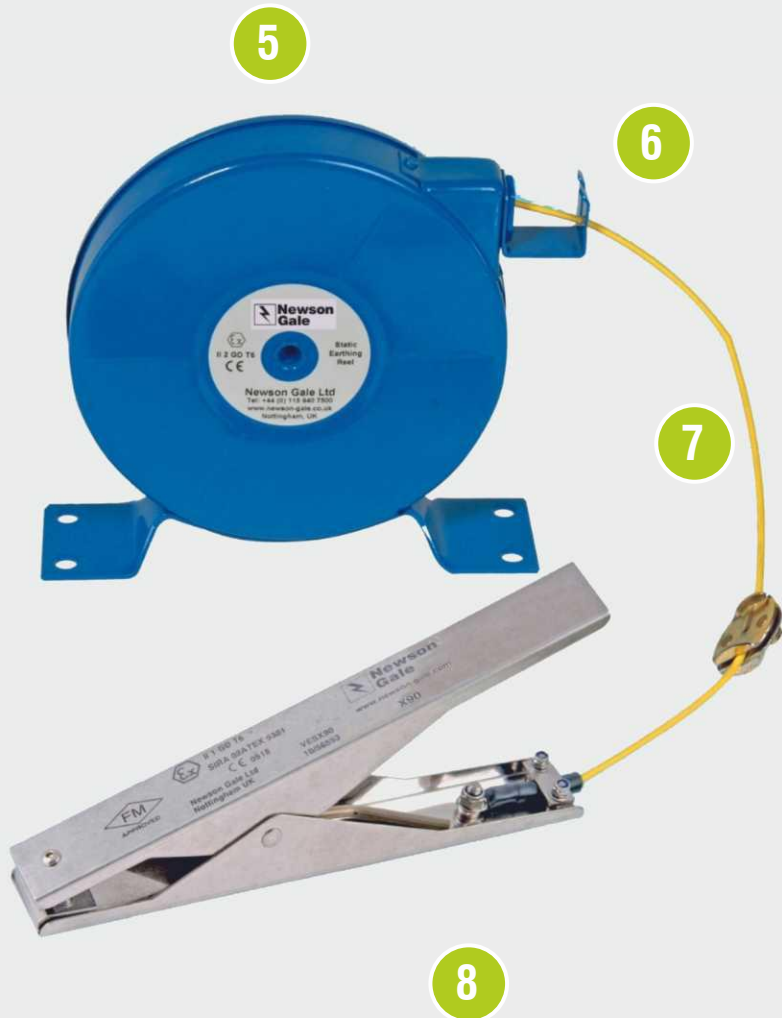

### Global Certification

UKCA & ATEX certified  
(Reel 20, 30 and 50)

FM Approved  
(Reel 20 & 30)



### Cable Lengths

The retractable cable reels are supplied in 6 m (20 ft), 9 m (30 ft) and 15 m (50 ft) lengths.



### Static Grounding Reels

Newson Gale's static grounding reels offer Hytrei® cable housed in a retractable cable reel. Stainless steel variants are available for clean processes such as pharmaceuticals.



### Integrated Storage Bracket

The retractable cable reels feature an integrated stowage bracket, ensuring grounding clamps are stowed correctly protecting the clamp from accidental damage or loss.



Scan QR Code  
to make an enquiry

## Cen-Stat™ Cable Reels Technical Specification

### Blue Powder Coated Retractable Cable Reels

Applications	Grounding and bonding metal objects ranging from small cans to 55 gallon drums (Medium size clamp) Grounding and bonding metal objects ranging from open top 55 gallon drums to large totes and Ex IBCs (Large size clamp)
Cable Length	6.1 m (20 ft), 9.1 m (30 ft), 15.2 m (50 ft)
Cable Supplied	Multi-stranded galvanized steel with Hytrel yellow coating
Cable Size	Conductor diameter 2.3 mm (3/32") galvanized cable conductor (4 mm <sup>2</sup> (11 AWG) cross sectional area) (3.2 mm (1/8") with Hytrel coating)
Reel Construction	Latchable spring mounted cable drum mounted in powder coated steel housing
Weight	Reel20 - 1.25 kgs Reel30 - 2.25 kgs Reel50 - 2.45 kgs



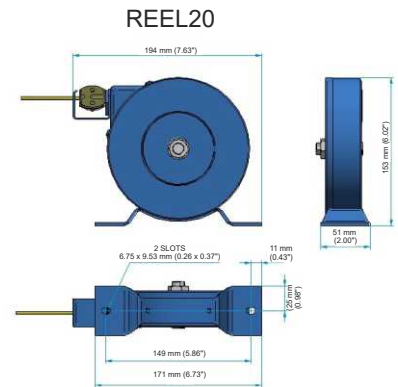

### ATEX / FM Reel Certification

ATEX	 II 2 G T6 II 2 D Ex h IIC T6 Gb Ex h IIIC T85°C Db Ambient Temperature -20°C to +40°C
FM	FM approved (R20 & R30)



### ATEX / FM / IECEx / UKEX Clamp Certification

ATEX	 II 1 GD T6 (Assessed to EN 13463-1 : 2009) Ta= -40°C to +60°C Sira 02ATEX9381 ATEX Notified Body: SIRA
FM	Certificate of Compliance
IECEx	Ex h IIC T6 Ga Ex h IIIC T85°C Da Ta = -40°C to +60°C IECEx EXV 20.0033 IECEx Certified Body: ExVeritas
UKCA Ex	 II 1 G II 1 D Ex h IIC T6 Ga Ex h IIIC T85°C Da Ta = -40°C to +60°C ExVeritas 21UKEX0842 UKCA Ex Approved Body: ExVeritas



# Cen-Stat™ Cable Reels Technical Specification

## Stainless Steel Retractable Cable Reels

Applications	Grounding and bonding metal objects ranging from small cans to 55 gallon drums (Medium size clamp) Grounding and bonding metal objects ranging from open top 55 gallon drums to large totes and Ex IBCs (Large size clamp)
Cable Length	6.1 m (20 ft), 9.1 m (30 ft), 15.2 m (50 ft)
Cable Supplied	Multi-stranded stainless steel with Hytrel yellow coating
Cable Size	Conductor diameter 2.3 mm (3/32") stainless steel cable conductor (4 mm <sup>2</sup> (11 AWG) cross sectional area) 3.2 mm (1/8") with Hytrel coating
Reel Construction	Latchable spring mounted cable drum mounted in Stainless steel (SS grade: 304) housing
Weight	Reel20 - 1.25 kgs Reel30 - 2.25 kgs Reel50 - 2.45 kgs



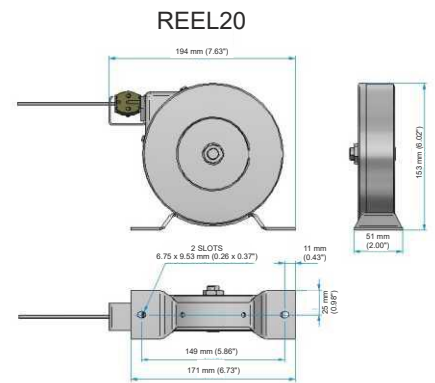

## ATEX Reel Certification

ATEX	 II 2 G T6  II 2 D Ex h IIC T6 Gb Ex h IIIC T85°C Db Ambient Temperature -20°C to +40°C
------	--



## ATEX / FM / IECEx / UKEX Clamp Certification

ATEX	 II 1 GD T6 (Assessed to EN 13463-1 : 2009) Ta = -40°C to +60°C Sira 02ATEX9381 ATEX Notified Body: SIRA
FM	Certificate of Compliance
IECEx	Ex h IIC T6 Ga Ex h IIIC T85°C Da Ta = -40°C to +60°C IECEx EXV 20.0033 IECEx Certified Body: ExVeritas
UKCA Ex	 II 1 G  II 1 D Ex h IIC T6 Ga Ex h IIIC T85°C Da Ta = -40°C to +60°C ExVeritas 21UKEX0842 UKCA Ex Approved Body: ExVeritas

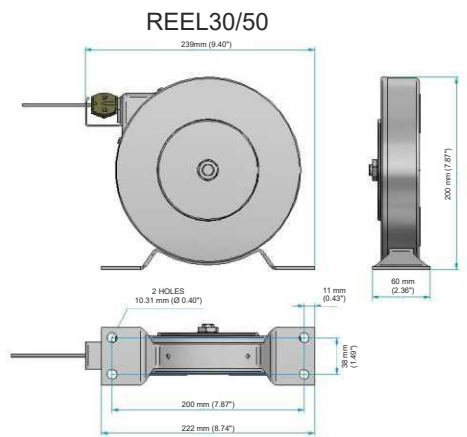



## Cen-Stat™ Cable Reels Technical Specification

### 30 m Retractable Cable Reels



Applications	Grounding and bonding metal objects ranging from small cans to 55 gallon drums (Medium size clamp) Grounding and bonding metal objects ranging from open top 55 gallon drums to large totes and Ex IBCs (Large size clamp)
Cable Lengths	30 m only
Cable Supplied	Multi-stranded galvanized steel with Hytrel yellow coating
Cable Size	Conductor diameter 2.3 mm (3/32") galvanized cable conductor (4 mm <sup>2</sup> (11 AWG) cross sectional area) 3.2 mm (1/8") with Hytrel coating
Reel Construction	Latchable spring mounted cable drum mounted in red powder coated housing Non-latchable self-retracting spring mounted cable drum mounted in red powder coated housing
Weight	10.4 kgs



### ATEX / FM Reel Certification

ATEX	 II 2 G T6  II 2 D Ex h IIC T6 Gb Ex h IIIC T85°C Db Ambient Temperature -20°C to +40°C
------	---

### ATEX / FM / IECEx / UKEX Clamp Certification

ATEX	 II 1 GD T6 (Assessed to EN 13463-1 : 2009) Ta = -40°C to +60°C Sira 02ATEX9381 ATEX Notified Body: SIRA
FM	Certificate of Compliance
IECEX	Ex h IIC T6 Ga Ex h IIIC T85°C Da Ta = -40°C to +60°C IECEx EXV 20.0033 IECEx Certified Body: ExVeritas
UKCA Ex	 II 1 G  II 1 D Ex h IIC T6 Ga Ex h IIIC T85°C Da Ta = -40°C to +60°C ExVeritas 21UKEX0842 UKCA Ex Approved Body: ExVeritas

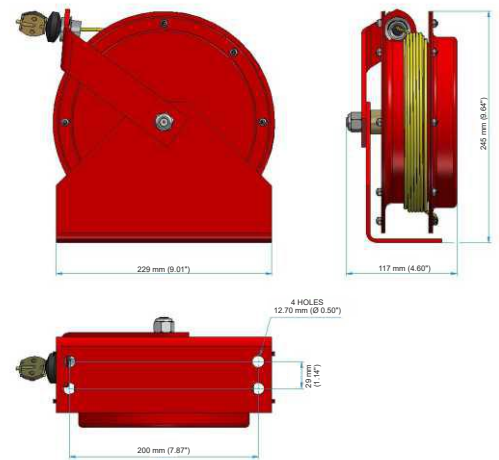



# Personnel Grounding Strap

The VESX45/PGS is a medium-duty stainless steel grounding clamp and wrist strap assembly designed to provide operators working in hazardous areas with an additional layer of protection.

It should be noted that grounding straps are not a substitute for static dissipative flooring or static dissipative footwear, and should only be used for rare occasions where process operators may lose contact between the soles of their static dissipative footwear and the plant floor.



The operating requirements of certain processes can cause the loss of direct contact between the operator's static dissipative safety shoes and the static dissipative flooring of the plant or facility. For example, an operator may need to stand on a ladder to tip powder into a large mixer and, in the process of moving to the ladder, loses contact with the static dissipative flooring.

To prevent static from accumulating on the operator, fastening the VESX45/PGS grounding strap to their wrist will ensure any charge generated by their movement can be dissipated to ground by direct contact to a verified ground connection.



## KEY FEATURES

- **ATEX/FM/IECEX** approved medium-duty stainless steel grounding clamp with tungsten carbide teeth mounted in a side-by-side configuration to provide a high degree of clamp stability with the ability to bite through rust, coatings and deposits of process material.
- **3.7 m** spiral cable fitted with a quick release connector enables operators to detach themselves in the event that they need to vacate the process area immediately.
- **1 meg-ohm** safety resistor mounted in the cable to limit stray electrical currents passing through the operator.
- Adjustable anti-allergy wrist strap to fit a wide range of wrist sizes.

## VESX45/PGS Technical Specification

### VESX45/PGS

Clamp Details	ATEX / FM / IECEx approved medium-duty static grounding clamp
Clamp Material	Stainless handles (SS grade: 304) and spring (SS grade: 302) Tungsten carbide teeth for maximum penetration
Clamp Dimensions	120 mm x 25 mm (4.7" x 1.0") Length x Width
Clamp Jaw Opening	13 mm (0.51") approx.
Wrist Strap	Anti-allergy adjustable strap
Electrical Safety Resistor	1 MΩ resistor mounted in the conductor
Cable Details	3.7 m (12 ft) single pole spiral conductor fitted to a quick release connector

Personnel Grounding Strap test kit is available on request.

\* Both section 11.4 of IEC TS 60079-32-1 and section 8.2.3.3 of NPFA 77 state the following:

“The simplest type of commercial device is an earthing bracelet with a built-in resistor typically giving a resistance to ground of about 100 kΩ for shock protection. Wrist straps of this type have the greatest utility at ventilation hoods and at other locations where limitation on the operator’s mobility can be tolerated. Breakaway wrist tether systems could be necessary where emergency egress is needed. A hood can be equipped with two external coiled earthing cords with cuff attachments that can be removed and kept by individual users.”

**IEC TS 60097-32-1:** Explosive atmospheres, Electrostatic Hazards, Guidance.

**NPFA 77** “Recommended Practice on Static Electricity”.

\* Always check for and read the latest version of the International Standards, Guidance and/or Recommended Practices.

## Hazardous Area Certification

### Europe / International

ATEX	 II 1 GD T6 (Assessed to EN 13463-1 : 2009) Ta = -40°C to +60°C Sira 02ATEX9381 ATEX Notified Body: SIRA
IECEx	Ex h IIC T6 Ga Ex h IIIC T85°C Da Ta = -40°C to +60°C IECEx EXV 20.0033

### North America Version Available

FM	Certificate of Compliance number: 3031650
----	---



# Earth-Rite® & Bond-Rite® Methods of Connection

## PROCESS EQUIPMENT CONNECTION OPTIONS



**Large Size Heavy-Duty Static Grounding Clamp**

For larger metal objects ranging from 55-gallon drums to metal totes and Ex IBC's.



**Medium Size Heavy-Duty Static Grounding Clamp**

For smaller metal objects ranging from small cans up to 55-gallon drums.



**Magnetic Static Grounding Clamp**

For any ferrous metal surface.



**Surface Mount Static Grounding Connector**

For mobile/semi-permanent process equipment.



# Earth-Rite® & Bond-Rite® Methods of Connection

Newson Gales' approved Dual Core Static Grounding Clamps ensure positive contact with the equipment to be grounded.

ATEX/IECEX certification assesses to reduce the risk of mechanical sparking, like thermite reactive materials such as aluminium, or sources of stored mechanical energy, present in the construction of the clamp.



## 5 Good Reasons to Specify ATEX, IECEx, UKEX and FM Approved Clamps

### 1 - Clamp Pressure Testing

Ensures the grounding clamp is capable of establishing and maintaining low resistance electrical contact with equipment (FM approvals).

### 2 - Electrical Continuity Testing

Ensures the electrical continuity from the teeth throughout the grounding clamp is less than 1 ohm (FM approvals).

### 3 - High Frequency Vibration Testing

Ensures the grounding clamp is capable of maintaining positive contact when attached to vibrating equipment (FM approvals).

### 4 - Mechanical Pull Testing

Ensures the grounding clamp cannot be pulled off the equipment without an intentional application of force (FM approvals).

### 5 - Sources of Mechanical Sparking

Ensures no mechanical sparking sources are present in the clamp (IECEx/ATEX certification).



## KEY FEATURES

- **Positive Contact:** The powerful combination of sharpened tungsten carbide teeth supported by a positive spring mechanism ensures coatings, product deposits or corrosion does not prevent the clamp from connecting directly to the equipment to be grounded.
- **Ergonomic:** Dual core clamps are designed to be easy to grip and open, aiding operators who have to make repetitive daily grounding connections.
- **Long Term Value:** Additional value is provided by the corrosion resistant and mechanically robust stainless steel construction which helps reduce long-term replacement costs that are typical of lower quality grounding clamps.
- **Quick Connect:** Allows quick and easy exchange of clamp and cable without the need of specialised tools or electrical personnel.



# Large Size Heavy-Duty Static Grounding Clamp

Dual core static grounding clamp designed for use with intrinsically safe grounding systems.



## 1

### FM Approved Clamps

FM approved clamps tested for:

#### Clamp Pressure

Ensuring the grounding clamp is capable of establishing and maintaining low resistance electrical contact with equipment.

#### Electrical Continuity

Ensuring the electrical continuity from the teeth throughout the grounding clamp is less than 1 ohm.

#### High Frequency Vibration

Ensures the grounding clamp is capable of maintaining positive contact when attached to vibrating equipment.

#### Mechanical Pull Test

Ensures the grounding clamp cannot be pulled off the equipment.

## 2

### Material & Construction

The clamp is made from heavy-duty SS304 grade stainless steel. It has a pair of sharp teeth made from tungsten carbide which is known for its hardness. When paired together in one solution, it provides a high degree of clamp stability which can bite through rust, coatings, and deposits of process material with ease.

## 3

### Clamp Teeth

Two tungsten carbide teeth set side-by-side in a stainless steel mounting block for extra stability.



# 7

## Global Certification

UKCA, IECEX, ATEX, and FM approved.

# 6

## Quick Connect Functionality

Quick connect functionality for easy removal out of the hazardous location.

# 4

## Maximum Jaw Opening

30 mm (1.18") approx.

# 5

## Spring Design

Newson Gale springs are designed and analysed with the aid of Finite Element Analysis technologies.



Scan QR Code to make an enquiry

# Medium Size Heavy-Duty Static Grounding Clamp

Dual core static grounding clamp designed for use with intrinsically safe grounding systems.



## 1

### FM Approved Clamps

FM approved clamps tested for:

#### Clamp Pressure

Ensuring the grounding clamp is capable of establishing and maintaining low resistance electrical contact with equipment.

#### Electrical Continuity

Ensuring the electrical continuity from the teeth throughout the grounding clamp is less than 1 ohm.

#### High Frequency Vibration

Ensures the grounding clamp is capable of maintaining positive contact when attached to vibrating equipment.

#### Mechanical Pull Test

Ensures the grounding clamp cannot be pulled off the equipment.

## 2

### Material & Construction

The clamp is made from heavy-duty SS304 grade stainless steel. It has a pair of sharp teeth made from tungsten carbide which is known for its hardness. When paired together in one solution, it provides a high degree of clamp stability which can bite through rust, coatings, and deposits of process material with ease.

## 3

### Clamp Teeth

Two tungsten carbide teeth set side-by-side in a stainless steel mounting block for extra stability.



# 7

## Global Certification

UKCA, IECEX, ATEX, and FM approved.

# 6

## Quick Connect Functionality

Quick connect functionality for easy removal out of the hazardous location.

# 4

## Maximum Jaw Opening

13 mm (0.51") approx.

# 5

## Spring Design

Newson Gale springs are designed and analysed with the aid of Finite Element Analysis technologies.



Scan QR Code to make an enquiry

# Magnetic Static Grounding Clamp

Dual core magnetic static grounding clamp designed for use with intrinsically safe grounding systems.



## 1

### Product Compatibility

The VESX50-IP dual core magnetic grounding clamp is fully compatible with the Newson Gale Bond-Rite® and Earth-Rite® monitoring systems that provide the customer with visual indication and interlock capability.

## 2

### Material & Construction

The clamp is made from heavy-duty SS304 grade stainless steel. It has a pair of sharp teeth made from tungsten carbide which is known for its hardness. When paired together in one solution, it provides a high degree of clamp stability which can bite through rust, coatings, and deposits of process material with ease.

## 3

### Tungsten Carbide Teeth

The powerful combination of sharp spring loaded tungsten carbide teeth complimented by the strength of the two neodymium magnets ensure that coatings, product deposits or corrosion do not prevent the clamp from making a low resistance connection (10 ohms or less) to the equipment to be grounded.

## 4

### Quick Connect Functionality

Quick connect functionality for easy removal out of hazardous location.



# 5

## Ergonomic

Dual core magnetic clamps have an integral handle and are therefore easy to grip, roll on, and roll off when operators have to make repetitive daily grounding connections.

# 6

## Global Certification

UKCA and IECEx approved.



Scan QR Code to make an enquiry

# Surface Mount Grounding Connector

Surface mount grounding connector designed for use with intrinsically safe grounding systems.



## 1

### Dedicated Grounding Point

Operators tasked with grounding mobile/semi-permanent process equipment will have a dedicated grounding point to attach the easy-to-use screw thread connector.

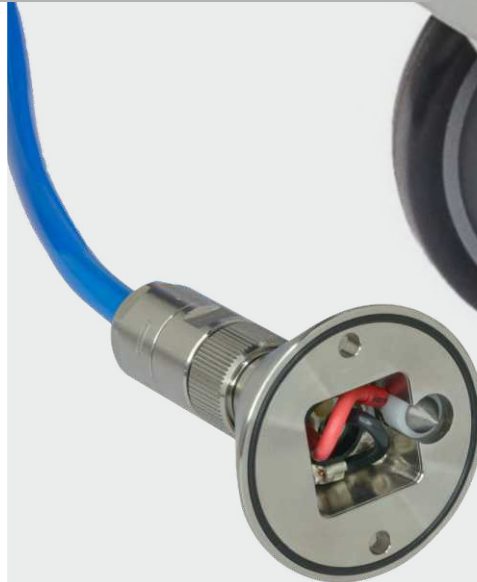

## 2

### Surface Mount Design

Offers a positive and secure contact with the equipment to be grounded, providing reliable grounding for safety.

## 3

### Conical Shape Design

The conical shape design aids in the reduction of powder deposit buildup over time and aids in clean down operations.

## 4

### 'Plug & Play' Connector

A dedicated grounding point on site with a screw thread connector. The 'plug and play' connector can interface with Newson Gale earthing/grounding systems to provide earth monitoring capability on a wide range of mobile/semi-permanent processes and equipment where generic grounding clamps cannot be used.



**Global Certification**

UKCA and IECEx approved.



Scan QR Code  
to make an enquiry



## Dual Core Clamps Technical Specification

### VESX90-IP - Large size heavy-duty static grounding clamp with Cen-Stat™ cable

Applications	Grounding and bonding metal objects ranging from 55 gallon drums to large metal totes and Ex IBCs
Clamp Material	Stainless Steel (SS grade: 304)
Operating Temperature	-40°C to +60°C
Dimensions	237 mm x 105 mm x 33 mm (9.33" x 4.1" x 1.3")
Maximum Jaw Opening	30 mm (1.18") approx.
Clamp Teeth	2 tungsten carbide teeth - set side by side in a stainless steel mounting block for extra stability
Clamp Weight	0.437 kgs (0.96 lbs)
Spring	Torsion spring Stainless Steel (SS Grade: 302)
Cable	Dual core Cen-Stat blue spiral cable with Hytrel coating which has UV and static dissipative additives
Cable Length	3 m (10 ft), 5 m (16 ft), 10 m (32 ft) or 15 m (50 ft)
Cable Size	Conductor cross sectional area - 1 mm <sup>2</sup> (17 AWG) approx. Copper with Cen-Stat coating - 7.5 mm (0.3") diameter



### ATEX / FM / IECEx / UKEX Clamp Certification

ATEX	<p>  II 1 GD T6                      (Assessed to EN 13463-1 : 2009)                      Ta = -40°C to +60°C                      Sira 02ATEX9381                      ATEX Notified Body: SIRA                 </p>
FM	<p>                     Certificate of Compliance No: 3046346                 </p>
IECEx	<p>                     Ex h IIC T6 Ga                      Ex h IIIC T85°C Da                      Ta = -40°C to +60°C                      IECEx EXV 20.0033                      IECEx Certified Body: ExVeritas                 </p>
UKCA Ex	<p>  II 1 G                      II 1 D                      Ex h IIC T6 Ga                      Ex h IIIC T85°C Da                      Ta = -40°C to +60°C                      ExVeritas 21UKEX0842                      UKCA Ex Approved Body: ExVeritas                 </p>



## Dual Core Clamps Technical Specification

### VESX45-IP - Medium size heavy-duty static grounding clamp with Cen-Stat™ cable

Applications	Grounding and bonding metal objects ranging from small cans to 55 gallon drums
Clamp Material	Stainless Steel (SS grade: 304)
Operating Temperature	-40°C to +60°C
Dimensions	120 mm x 60 mm x 25 mm (4.72" x 2.36" x 0.98")
Maximum Jaw Opening	13 mm (0.51") approx.
Clamp Teeth	2 tungsten carbide teeth - set side by side in a stainless steel mounting block for extra stability
Clamp Weight	0.183 kgs (0.40 lbs)
Spring	Torsion spring Stainless Steel (SS Grade: 302)
Cable	Dual core Cen-Stat blue spiral cable with Hytrel coating which has UV and static dissipative additives
Cable Length	3 m (10 ft), 5 m (16 ft), 10 m (32 ft) or 15 m (50 ft)
Cable Size	Conductor cross sectional area - 1 mm <sup>2</sup> (17 AWG) approx. Copper with Cen-Stat coating - 7.5 mm (0.3") diameter



### ATEX / FM / IECEx / UKEX Clamp Certification

ATEX	 II 1 GD T6 (Assessed to EN 13463-1 : 2009) Ta = -40°C to +60°C Sira 02ATEX9381 ATEX Notified Body: SIRA
FM	Certificate of Compliance No: 3046346
IECEx	Ex h IIC T6 Ga Ex h IIIC T85°C Da Ta = -40°C to +60°C IECEx EXV 20.0033 IECEx Certified Body: ExVeritas
UKCA Ex	 II 1 G II 1 D Ex h IIC T6 Ga Ex h IIIC T85°C Da Ta = -40°C to +60°C ExVeritas 21UKEX0842 UKCA Ex Approved Body: ExVeritas

## Dual Core Clamps Technical Specification

### Surface Mount Connector static grounding clamp

Applications	Grounding and bonding metal objects such as large metal totes and Ex IBCs
Clamp Material	Stainless Steel (SS grade: 304 body) Viton (O-Ring) Tungsten Carbide Tip
Ingress Protection	IP66
Operating Temperature	-40°C to +60°C
Dimensions	72 mm x 49 mm DIA
Clamp Weight	0.20 kgs (nett)
Cable Options	3 m (10 ft), 5 m (16 ft), 10 m (32 ft) or 15 m (50 ft) dual core Cen-Stat blue spiral cable with Hytrel coating which has UV and static dissipative additives
Cable Size	Conductor cross sectional area - 1 mm <sup>2</sup> (17 AWG) approx. Copper with Cen-Stat coating - 7.5 mm (0.3") diameter diameter



### IECEX / UKEX Clamp Certification

IECEX	Ex h IIC T6 Ga Ex h IIIC T85°C Da Ta = -40°C to +60°C IECEX EXV 20.0033 IECEX Certified Body: ExVeritas
UKCA Ex	 II 1 G II 1 D Ex h IIC T6 Ga Ex h IIIC T85°C Da Ta = -40°C to +60°C ExVeritas 21UKEX0842 UKCA Ex Approved Body: ExVeritas

## Dual Core Clamps Technical Specification

### Magnetic Clamp static grounding clamp

Applications	Grounding and bonding metal objects ranging from small cans to 55 gallon drums
Clamp Material	Stainless Steel SS304/A2 Body, Stainless Steel Springs, Nylon, Viton 'O' Ring, Tungsten Carbide Tips and Neodymium Magnets
Operating Temperature	-40°C to +60°C
Dimensions	133 mm x 36 mm x 96 mm
Clamp Weight	0.52 kgs (nett)
Cable Options	3 m (10 ft), 5 m (16 ft), 10 m (32 ft) or 15 m (50 ft) dual core Cen-Stat blue spiral cable with Hytrel coating which has UV and static dissipative additives
Cable Size	Conductor cross sectional area - 1 mm <sup>2</sup> (17 AWG) approx. Copper with Cen-Stat coating - 7.5 mm (0.3") diameter



### IECEX / UKEX Clamp Certification

IECEX	Ex h IIC T6 Ga Ex h IIIC T85°C Da Ta = -40°C to +60°C IECEX EXV 20.0033 IECEX Certified Body: ExVeritas
UKCA Ex	 II 1 G II 1 D Ex h IIC T6 Ga Ex h IIIC T85°C Da Ta = -40°C to +60°C ExVeritas 21UKEX0842 UKCA Ex Approved Body: ExVeritas

# Testing Equipment

## HOSE & FOOTWEAR TESTING EQUIPMENT

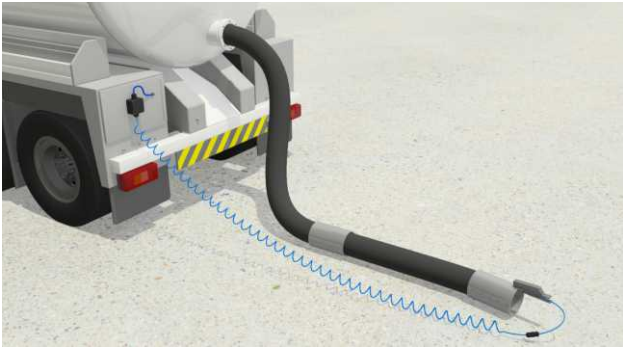

**OhmGuard<sup>®</sup>**  
Intrinsically safe continuity tester.



**Sole-Mate<sup>™</sup> II**  
Static dissipative footwear tester.



# OhmGuard®

The OhmGuard® electrical continuity tester is designed to test hoses used on vacuum trucks, road tankers and plant equipment prior to the transfer of flammable or combustible products. It can also be used as an effective method of checking static bonding assemblies and conductors relative to verified grounding points.

The OhmGuard® is easy to operate, however, operator training is essential and is the responsibility of the customer/end user facility. The OhmGuard® indicates if the resistance through the metal components of hoses (e.g., internal wire helixes, metal couplings) are below specified resistance thresholds.



IECEX



The metal helical wires that reinforce hoses against discharge and suction pressures are commonly used to provide an electrical bond between the end fittings or couplings of hoses.

The OhmGuard<sup>®</sup> resistance tester can help with the identification of breaks in continuity. It should be noted that the OhmGuard<sup>®</sup> indicates if the electrical continuity of the metal helix, bonding wires, and couplings are below the specified resistance threshold.

Correct grounding of these components is the responsibility of the end user/customer.



## KEY FEATURES

- Proves the hoses have good electrical continuity with the grounded truck.
- Ensures potentially isolated components of plant equipment are identified and remedied.
- One-time test with visual "GO/NO-GO" indication.
- Enables early detection of faults without the need to wait for scheduled periodic testing.
- Easy to operate. Drivers and operators do not need electrical training.
- Intrinsically Safe certification for Ex area requirements.
- Lower cost than equivalent Ex area approved multimeters.
- Robust stainless steel construction, more durable than other multimeters in the field.
- Tungsten carbide teeth help penetrate any slurries or deposits caked onto the hose end fitting.

# OhmGuard®

Intrinsically safe  
hose continuity  
tester.

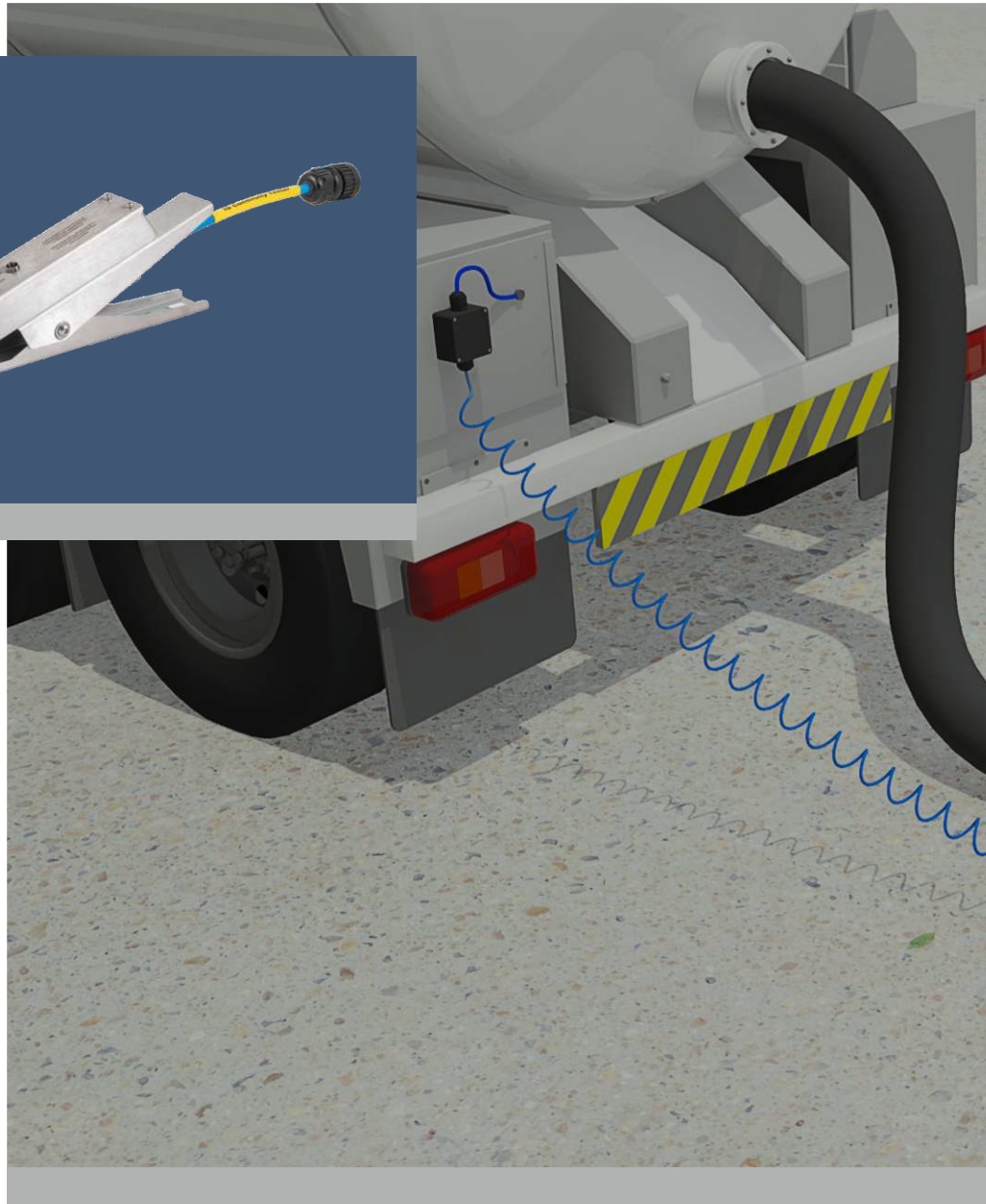
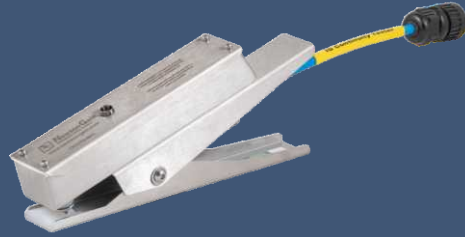

## 1

### Robust Stainless Steel Construction

Robust stainless steel construction, offering greater durability and longevity than other multimeters in the field.

## 2

### Tungsten Carbide Teeth

Strong and durable tungsten carbide teeth effectively penetrate slurries or deposits caked onto the hose end fitting.

## 3

### Clear “GO/NO-GO” Indication

A one-time test provides operators with a simple “GO/NO-GO” indication via a high intensity, visible flashing green LED mounted on the lid of the OhmGuard®.

## 4

### Good Electrical Continuity

Proves the hoses have good electrical continuity with the grounded truck.

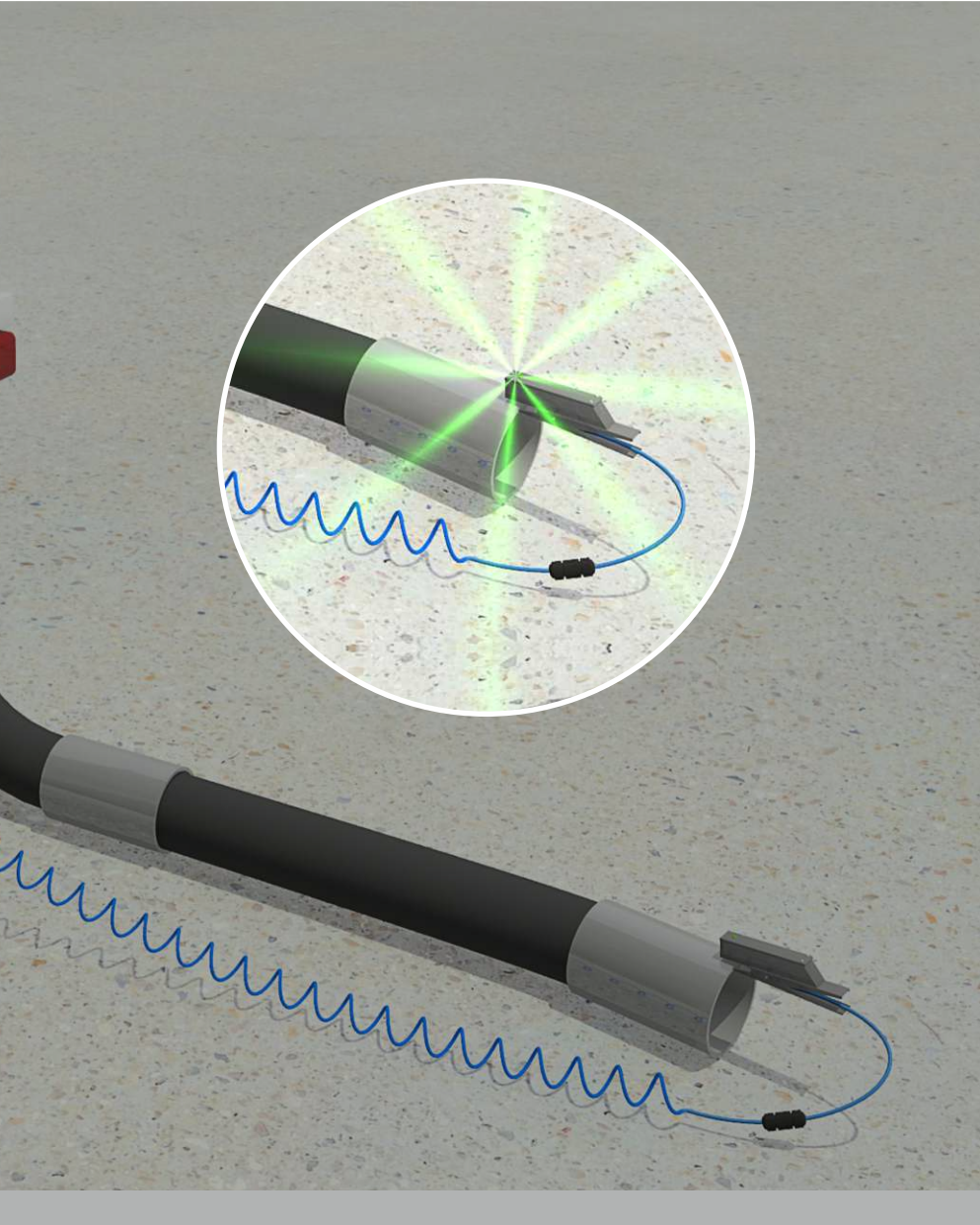

# 8

## Fault Detection

Provides operators with a visual indication of a true connection via a flashing green LED, enabling early detection of faults and component errors without waiting for scheduled periodic testing.

# 7

## Versatile Testing Capability

Tests hoses, static bonding assemblies, and conductors against verified grounding points.

# 5

## Intrinsically Safe (IS)

Compliant with Ex requirements for safety.

# 6

## Easy To Operate

Requires minimal training for drivers and operators.



Scan QR Code to make an enquiry

## OhmGuard® Technical Specification

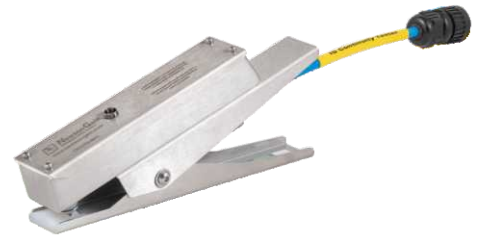

### Product Details

Ingress protection	IP64
Operating Temperature	-40°C to +60°C
Monitored loop resistance (0-100 ohm Clamp)	100 Ω maximum
Monitored loop resistance (0-10 ohm Clamp)	10 Ω maximum
Indicator Lamp LED	1 green (Hose continuity good)
Clamp Dimensions	Length: 237mm Width: 34 mm
Weight	0.9 kgs



## Hazardous Area Certification

### Europe/International

IECEX	Ex ia IIC T4 Ga Ex ia IIIC T135°C Da Ta = -40°C to +60°C IECEX EXV 19.0058 IECEX Certifying Body: ExVeritas
ATEX	 II 1 G II 1 D Ex ia IIC T4 Ga Ex ia IIIC T135°C Da Ta = -40°C to +60°C ExVeritas 19ATEX0543 ATEX Notified Body: ExVeritas
UKCA Ex	 II 1 G II 1 D Ex ia IIC T4 Ga Ex ia IIIC T135°C Da Ta = -40°C to +60°C ExVeritas 21UKEX0834 UKCA Ex Approved Body: ExVeritas
CCC	Ex ia IIC T4 Ga Ex ia IIIC T135°C Da Ta = -40°C to +60°C 2021312309000481 Approved Body: CNEX
KCS (Gas)	Ex ia IIC T4 Ga Ta = -40°C to +60°C 22-AV4BO-0298X Approved Body: KOSHA
KCS (Dust)	Ex ia IIIC T135°C Da Ta = -40°C to +60°C 22-AV4BO-0299X Approved Body: KOSHA

### North America Version Available:

NEC 500 / CEC  
(Class & Division)

Class I Div 1, Groups, A, B, C, D  
 Class II Div 1, Groups. E, F, G  
 Class III, Div. 1.  
 Temperature Code: T4  
 Ta = -40°F to +140°F (-40°C to +60°C)  
 OSHA recognised NRTL: CSA



The extension assembly consists of an alligator clip, a test probe and stainless steel plate. It is ideal for testing equipment that does not have a large enough surface to connect to with the OhmGuard® clamp.

The person performing the test simply connects the OhmGuard's clamp contacts to the plate and then connects the probe or alligator clip to the equipment being tested.



# Sole-Mate™ II

The Sole-Mate™ II is a user-friendly device that is designed to check the condition of static dissipative footwear prior to entering safety critical hazardous areas exposed to potentially ignitable atmospheres.

The Sole-Mate™ II provides a time efficient and cost effective method for personnel operating in hazardous areas to ensure that their static dissipative shoes are capable of mitigating electrostatic charge accumulation on their bodies.



The Sole-Mate™ II checks the electrical resistance condition of the shoes resistance through the electrical loop of the operator and their footwear.

If the resistance of the shoes is too high, the Sole-Mate™ II will indicate that the shoes have failed the check via a red lamp and buzzer alarm. If the shoes pass the check a green lamp will indicate to the operator that the shoes are fit for purpose.

Additionally, users can interlock the Sole-Mate™ II with audible alarms or entry doors into hazardous areas so that personnel not wearing suitable footwear cannot enter the hazardous area.



## International Standards

Based on user preference, the Sole-Mate™ II can be ordered to check upper level resistance as defined by the following standards:

- EN ISO 20345 —  $1 \times 10^9$  ohm
- IEC TS 60079-32-1 —  $1 \times 10^8$  ohm
- ASTM F2413 —  $1 \times 10^8$  ohm
- CAN/CSA Z195-14 —  $1 \times 10^8$  ohm

Sole-Mate™ II units are available with resistance levels of  $1 \times 10^8$  or  $1 \times 10^9$  ohm.

### PLEASE NOTE

Equipment specifiers must ensure that the Sole-Mate™ II Tester resistance level selected is compatible with the static dissipative shoes in use within the hazardous area. E.g., a  $1 \times 10^8$  ohm resistance level should not be selected for EN ISO 20345 compatible shoes.

### Sole-Mate™ II Resistance Tester

The resistance test unit can be used at regular intervals (every 6 or 12 months) to ensure the upper resistance threshold of the footwear tester is operating at the correct level.

# Sole-Mate™ II

Static dissipative footwear tester.



## 1

### Footwear Resistance Testing

Checks the resistance of static dissipative footwear to ensure it meets specified safety standards/guidance (e.g., EN ISO 20345, IEC TS 60079-32-1, NFPA 77).

## 2

### Resistance Options

Different versions to match the upper specific resistance ranges of footwear standards, ensuring versatile use across various operational needs.

## 3

### Clear PASS or FAIL Indication

Clear PASS (green LED) or FAIL (red LED) visual indication for quick and easy results.

## 4

### Audible Alarm

Equipped with an audible alarm to alert personnel of PASS or FAIL results instantly.





# 5

## Interlock Capability

Can be integrated with entry systems and alarms to permit or deny access based on results, enhancing safety protocols.



Scan QR Code to make an enquiry

## Technical Articles

# STATIC ELECTRICITY AND ITS ROLE AS A POTENTIAL IGNITION SOURCE IN Ex ATMOSPHERES





**Static Electricity and its Role as a Potential Ignition Source in Ex Areas**

**138**



**Criteria for Selecting Static Grounding Equipment**

**144**



**Controlling the Risk of Electrostatic Ignitions in Ex/HAZLOC Operations**

**148**



**Specification of Hazardous Area Certified equipment**

**156**

# STATIC ELECTRICITY AND ITS ROLE AS A POTENTIAL IGNITION SOURCE IN Ex/HAZLOC AREAS

Static electricity can be described in a number of different ways, but it is, essentially, electricity stuck in one place. In a normal electrical circuit, charges that form an electrical current move through a closed circuit in order to do something beneficial, like power a computer or the lighting in your house. In these circuits, the charge always returns to the source from which it has been supplied. Static electricity is different. Because it is not part of a closed circuit static electricity can accumulate on plant equipment ranging from road tankers to flexible intermediate bulk containers.

Although static electricity is generally regarded as a nuisance, in the hazardous process industries it can become an ignition source. Discharges of static electricity have been identified as the ignition source in a broad range of processes. It is as potent as sparks resulting from mechanical and electrical sources, and yet, it is often underestimated, either due to a lack of awareness of the risks it poses or because of neglect and/or complacency.



## Legislation concerning static electricity in hazardous area process industries

The ignition risk posed by static electricity is addressed in European and North American legislation. In Europe, Annex II of the **ATEX Directive 2014/34/EU** within Section 1.3.2 states “Hazards arising from static electricity: – Electrostatic charges capable of resulting in dangerous discharges must be prevented by means of appropriate measures”. Thus, “electrostatic discharges” are a known potential ignition source and must be considered as part of the explosion risk assessment.

In the US, the **Code of Federal Regulations** that addresses hazardous location activities, 29 CFR Part 1910 “Occupational Safety and Health Standards”, states that all ignition sources potentially present in flammable atmospheres, including static electricity, shall be mitigated or controlled.

**Section 10.12 of Canada’s Occupational Health and Safety Regulations (SOR/86-304)** states that if a substance is flammable and static electricity is a potential ignition source that the employer “*shall implement the standards set out in the United States National Fire Protection Association, Inc. publication NFPA 77, Recommended Practice on Static Electricity.*”

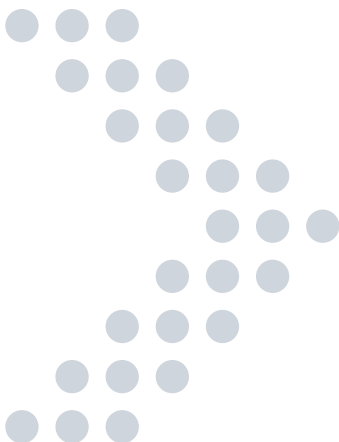

## Industry Code of Practice

**NFPA 77 “Recommended Practice on Static Electricity”** is one of a number of industry codes of practice that addresses the ignition hazards of static electricity. In recognition of the ignition risks posed by static electricity these publications are produced and edited by committees of technical experts that participate in the hazardous process industries. The following publications are dedicated to helping QHSE professionals and plant engineers identify and control electrostatic ignition sources.



All information provided is in line with **IEC TS 60079-32-1 “Explosive atmospheres – Part 32-1: Electrostatic hazards, guidance”** and **NFPA 77 “Recommended Practice on Static Electricity.”** This information is readily available in the public domain; contact [www.IEC.ch](http://www.IEC.ch) and [www.NFPA.org](http://www.NFPA.org)

Note: In providing this advice, Newson Gale is not undertaking to render professional or other services for or on behalf of any person or entity, nor undertaking to perform any duty owed by any person or entity to someone else. Anyone using this information should rely on his or her own judgment or, as appropriate, seek the advice of a competent professional in determining the exercise of reasonable care in any given circumstance.

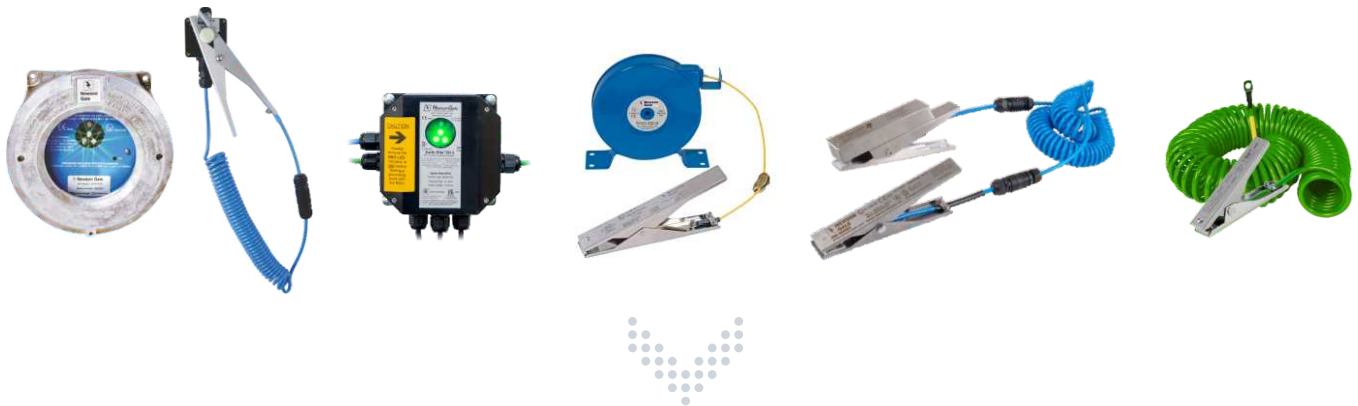

### List of industry codes of practice designed to prevent ignitions caused by static electricity

Publisher	Title	Metal Grounding Circuits	FIBC Type C
International Electrotechnical Commission	IEC TS 60079-32-1: Explosive Atmospheres, Electrostatic Hazards Guidance	10 Ω	1 x 10 <sup>8</sup> Ω
National Fire Protection Association	NFPA 77: Recommended Practice on Static Electricity	10 Ω	1 x 10 <sup>8</sup> Ω
American Petroleum Institute	API RP 2003: Protection against Ignitions Arising out of Static, Lightning and Stray Currents	10 Ω*	N/A
American Petroleum Institute	API 2219: Safe Operation of Vacuum Trucks in Petroleum Service	10 Ω	N/A
International Electrotechnical Commission	IEC 61340-4-4: Electrostatic classification of Flexible Intermediate Bulk Containers	N/A	1 x 10 <sup>8</sup> Ω

\*API RP 2003 states that 10 Ω is ‘satisfactory’

**NOTE:** Always check for and read the latest version of the International Standards and/or Recommended Practices.

### The basics of the hazard

When a high resistivity liquid, gas or powder becomes electrostatically charged during process operations, it could charge electrically isolated conductive plant, equipment and materials that are in direct contact with it, or in close proximity to it.

It is scenarios where the hidden increase in the voltage of the charged object presents the static ignition risk. This is because static sparks are caused by the rapid ionisation of the atmosphere between the charged object and objects that are at a lower voltage. When the voltage of the object hits a critical level that exceeds the breakdown voltage of the medium present in the gap between the charged object, C1, and uncharged object, C2, ionisation occurs, which presents a conductive path for the charges to pass through the gap in the form of a spark.

The total energy available for discharge is based on the voltage (V) of the object and its capacitance (C) based on the formula shown:

$$V = \frac{Q}{C}$$

Where:

- V = voltage of charged object (Volts)
- Q = total quantity of charge on the object (Coulombs)
- C = capacitance of charged object (Farad)

(Source: NFPA 77: 6.3.1)

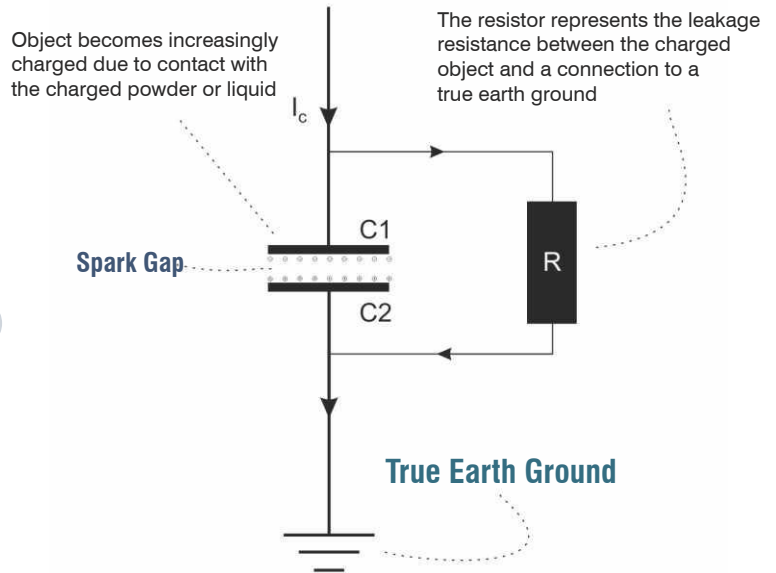

Figure 1: Basic model of why objects can accumulate static electricity. Ref: IEC TS 60079-32-1, Figure A.1

Liquid / Gas	MIE
Methanol	0.14 mJ
MEK	0.53 mJ
Ethyl Acetate	0.46 mJ
Acetone	1.15 mJ
Benzene	0.20 mJ
Toluene	0.24 mJ

Table 2a\*: List of flammable liquids and gases and their corresponding Minimum Ignition Energies

### Examples of Minimum Ignition Energies

The Minimum Ignition Energy (MIE) is the lowest energy required to ignite flammable materials. Tables 2a and 2b highlights various materials and their MIE values.

\*\*The figures listed in Tables 2a and 2b are indicative examples of the MIE. Confirmation of the actual product MIE should be sought from the product supplier.

Powder	MIE
Magnesium Stearate	03 mJ
Polyethylene	10 mJ
Aluminium	50 mJ
Cellulose Acetate	15 mJ
Sulphur	15 mJ
Polypropylene	50 mJ

Table 2b\*: List of combustible powders and their corresponding Minimum Ignition Energies

## Real World Scenarios

As described in Figure 1 the objective of grounding is to mitigate electrostatic voltage increase during the process. Charge accumulation is likely to occur if there is a high enough resistance present between the equipment and general mass of earth.

Connections to the mass of the earth should be provided by high integrity earth grounds present on the site. These high integrity earth grounds will normally be providing paths to ground for lightning and electrical fault currents and should be suitable for dissipating static electricity (ref: **NFPA 77, 7.3.1.6.1**).

The performance and condition of high integrity grounding points are the responsibility of the site owner and need to be verified on a regular basis by a site appointed competent electrical person.

**Tables 2a and 2b** detail MIE of some common liquids and powders used in process industries. If an object becomes isolated and the static voltage increases on it then the charge on the object can quickly achieve a value above the products MIE and therefore be capable of igniting these flammable materials.

### But what can cause equipment to become isolated?

**Tables 3a and 3b** provides examples of equipment that can become isolated and the reasons for it.



### Examples of Capacitance of various items

Item	Capacitance (pF)
Tank car	1000
Automobile	500
Person	100 - 300
Oil/Solvent drum	10 - 100
Metal scoop	10 - 20
Needle electrode	1
Dust particule	10 <sup>-7</sup>

Table 3a: Examples of Capacitance  
IEC TS 60079-32-1: Table A2  
NFPA 77: Table A.3.3.5



### Causes of Capacitance

Objects	What causes capacitance?
Portable drums	Protective coatings, product deposits, rust
Road tankers	Rubber tyres
Piping	Rubber and plastic seals, anti-vibration pads and gaskets
Rail tankers	Grease, vibration pads isolating tank from rails. Rails isolated from loading gantry
Hoses	Broken internal helixes and bonding connectors
FIBC	Non-conductive fabric/damaged static dissipative threads
People	Human bodies
Scoops	Material of construction

Table 3b: Equipment at risk of static charge accumulation and what can cause electrical isolation

## Operator Training

Operator training is essential and should not be overlooked. Operators working in Ex/HAZLOC areas should be trained on the basics of static electricity as a potential ignition source as they are, ultimately, the day-to-day users of the grounding and bonding equipment that has been specified and installed at the site.

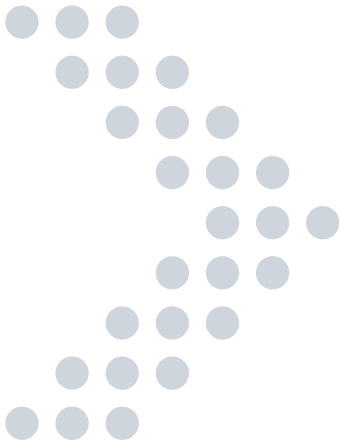

They should be trained on the intended function and correct use of the grounding equipment and where the use of the grounding equipment fits within the standard operating procedures of the company. As a basic minimum for most application scenarios (e.g., grounding a metal drum) they should follow the principle of making grounding connections as the first step in the process and to not remove the ground connection until the process is complete.

Operators should be trained to avoid scenarios where, for example, if grounding systems interlocked with the process have their grounding connections removed during the process, thereby initiating an emergency shutdown of the process (e.g., switching off a pump), there could still be movement of material after the machine has stopped, thereby carrying the risk of continued static charge generation.

If operators notice that equipment has been changed or damaged (e.g., fraying cable connections) they should be encouraged to report this to the relevant person at the location (line manager, local QSHE, maintenance personnel) and not use the equipment until a competent person has deemed the equipment safe and appropriate for use.



Not providing the correct training or not following company standard operating procedures, with respect to electrostatic controls, risks the incorrect use of the grounding equipment.

## General static grounding and bonding requirements

Where asset owners deem it necessary to provide static grounding for equipment of metallic construction this can be achieved by connecting the equipment to a verified true earth ground.

The true earth ground provided by the site owner should have a low resistance connection to the general mass of the earth.

For the resistance between the object that is being grounded via the verified true earth ground (e.g., installed busbar network using copper grounding cables) less than 10  $\Omega$  is specified as the benchmark for metal-to-metal circuits. This recommendation is based on the idea that indicators of loose connections and corrosion will show electrical resistances higher than 10  $\Omega$ . (IEC TS 60079-32-1 and NFPA 77, 2024).

Options ranging from basic clamps to grounding systems can be specified. Systems with ground status indicators can provide operators with the benefit of a visual indication of a 10  $\Omega$  or less connection to the metal object to be grounded. An additional control can be the use of a grounding system with an interlock function. This would require a permissive output from the grounding system's contact with the site owner's process that is controlling the initiation of the process. This supports the principle of "**Clamp On First, Clamp Off Last**", so that grounding of the equipment is the first step in the process.

When the grounding system establishes a 10  $\Omega$  or less connection between the equipment and verified true earth ground the ground status indicators switch from red to flashing green. Such a grounding system will monitor the resistance between the object requiring grounding and the site verified true earth ground to 10  $\Omega$  or less. It should be emphasised that the grounding system is establishing a circuit between the object to be grounded and the site's verified true earth ground network. It is not verifying if the true earth ground network has a connection to the general mass of the earth.

It is the site owner's responsibility to verify that the ground network has a low enough resistance connection to the general mass of earth based on their national electrical grounding and lightning protection standards.

As with any item of equipment it is essential that the grounding system is installed in accordance with the instruction manual. If the system is not installed in accordance with the instruction manual and the hazardous area certificate, the safe operation of the system and the warranty are both invalidated.

Ground connections should never be removed when the process is underway and should never be attached if the operator has not followed the "Clamp On First" principle, e.g., where the process has started before the grounding clamp has been attached as this could lead to a static discharge.



# CRITERIA FOR SELECTING STATIC GROUNDING EQUIPMENT

Experience of selecting solutions to mitigate against the ignition hazards of static electricity in Ex areas varies from those who are specifying static control solutions for the first time to those who specify solutions on a regular basis.

Although static electricity's role in igniting potentially combustible atmospheres is generally less well known than sources like electrical or mechanical sparks, there are dedicated International Standards and Recommended Practices that can provide a broad overview of the kinds of processes that can be susceptible to electrostatic discharges.

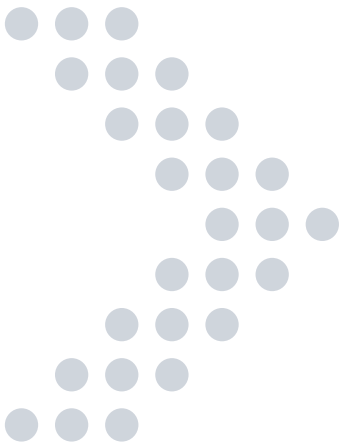
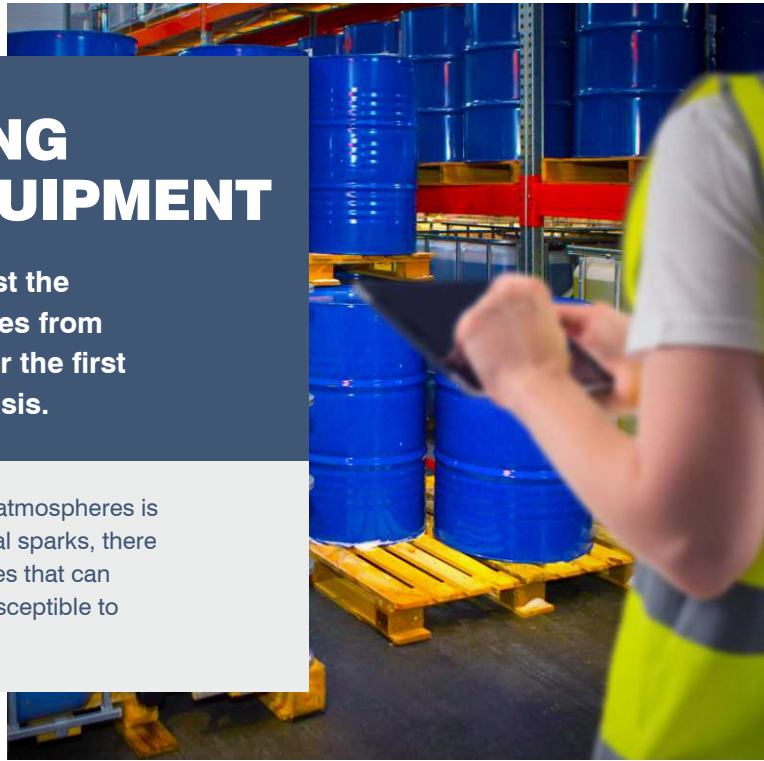

## Recommended Practice on Static Electricity

Two publications that provide a broad overview of static electricity and its role as an ignition source in operations carried in Ex areas are **IEC TS 60079-32-1** "Explosive Atmospheres, Electrostatic Hazards, Guidance."\* and **NFPA 77** "Recommended Practice on Static Electricity."

\* This "Technical Specification" has been adopted by **CENELEC** and is referred to as *CLC/TR 60079-32-1 "Explosive atmospheres. Electrostatic hazards, guidance."*

While not every process capable of generating static electricity can be addressed in a single publication, the more commonly used metal objects used in industry like road tankers, railcars, intermediate bulk containers (Ex IBCs), drums or containers like FIBC are addressed.



### 13.1 of IEC TS 60079-32-1 - General

"By far the most effective method of avoiding hazards due to static electricity is to connect all conductors to earth. This will avoid the most common problem which is the accumulation of charge on a conductor and the release of virtually all the stored energy as a single spark, to earth or to another conductor."



### 3.3.23 of NFPA 77 - Grounding

"Connected (connecting) to ground or to a conductive body that extends the ground connection."

**Generally speaking, grounding electrically conductive objects used in processes that are capable of generating electrostatic charge prevents the accumulation of electrostatic charge by equalizing the potential difference of the object with respect to earth.**

If static charge is permitted to accumulate on an object (e.g. filling an electrically isolated metal drum), then a voltage rise is likely to develop whereby the voltage of the object exceeds the breakdown voltage of the atmosphere surrounding the point at which a static discharge could occur. The primary hazard is that if the energy of the static discharge is higher than the minimum ignition energies (MIE) of a combustible atmosphere that happens to be present at the location of the discharge, ignition could occur.

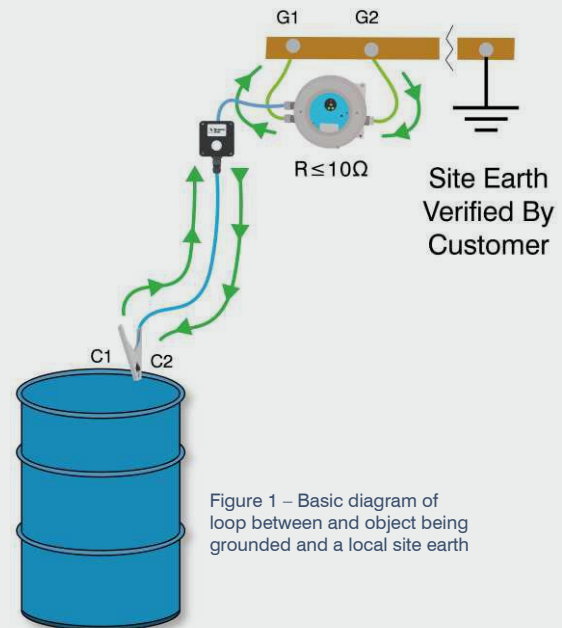

Figure 1 – Basic diagram of loop between and object being grounded and a local site earth

## Benchmark Values of Electrical Resistance

### 7.4.1.6.1 of NFPA 77:

“Where the bonding/grounding system is all metal, resistance in continuous ground paths is measured to verify mechanical integrity. (See A.3.3.2.)\* Such systems include those having multiple components. Greater resistance usually indicates that the metal path is not continuous, usually because of loose connections or corrosion. A permanent or fixed grounding system that is acceptable for power circuits or for lightning protection is more than adequate for a static electricity grounding system.....”

\*A.3.3.2 Bonding.

*A resistance not exceeding 10 ohms for copper wire or 25 ohms for stainless steel or other metals is typically found in practice. Higher resistances could indicate a lack of mechanical integrity.*

The electrical resistance between the object to be grounded and the general mass of earth is the critical benchmark for grounding equipment used in processes that could result in electrostatic charge accumulation.

Although 1 MΩ resistance to earth is generally accepted as a resistance level that is adequate for dissipating static electricity, both **IEC TS 60079-32-1** and **NFPA 77**, state that a resistance higher than 10 Ω on a metal circuit (including the object to be grounded) can be indicative of loose, corroded or broken connections. Although many static grounding systems will monitor connection resistances that fall within a range of 1 MΩ, a valid benchmark to set for a permissive condition could be to follow the recommendations of **IEC TS 60079-32-1** or **NFPA 77** of 10 Ω or less ( $R \leq 10 \Omega$ ).

### 13.2.2 “Practical Criteria” of IEC TS 60079-32-1:

“Metallic items in good contact with earth should have a resistance to it of less than 10 Ω. Although a value of up to

1 MΩ is acceptable for static dissipation, values above 10 Ω may give an early indication of developing problems (e.g. corrosion or a loose connection) and should be investigated. It is important that all connections are reliable, permanent and not subject to deterioration.”

Hence, the input criteria of a resistance of 10 Ω or less ( $R \leq 10 \Omega$ ) can be defined as a primary condition for a grounding solution to indicate a positive connection between the object and the site’s verified ground.

The connection to the general mass of earth should be established for an effective grounding system. Many sites use a dedicated static grounding network and/or permanently installed ground rods to provide a static dissipation path to earth. Dedicated static grounding rods and electrical grounding and lightning protection circuits should be tested on a regular basis to ensure a low resistance connection to the general mass of the earth is maintained for the service life of such apparatus. Interconnecting conductors e.g. (busbars) should also be tested regularly to ensure a low resistance connection between the grounding point for process equipment and the verified ground.

## 13.4 of IEC TS 60079-32-1

### The establishment and monitoring of grounding systems

#### 13.4.1 Design

“Where the bonding/earthing system is all metal, the resistance in continuous earth paths typically is less than 10 Ω. Such systems include those having multiple components. A greater resistance usually indicates that the metal path is not continuous, usually because of loose connections or corrosion. An earthing system that is acceptable for power circuits or for lightning protection is more than adequate for a static electricity earthing system.”

## Visual Indication of a Ground Connection

Day to day static grounding and bonding tasks are normally performed by process operators or vehicle drivers. In order to help operators and drivers follow static grounding standard operating procedures (SOPs), a visual reference of a ground connection can be a good reminder not to start the process until the grounding status of the equipment has been confirmed.

This can support a “Clamp On First, Clamp Off Last” procedure by reminding operators that they should have a verifiable ground connection before they commence the process (e.g., filling an Ex IBC) and not remove the ground connection until the process has been completed.

Green flashing LEDs are commonly used to convey a “good to go” situation. Flashing indicators can support the view that the grounding system is continuously monitoring the resistance of the connection to the equipment indicating that the overall resistance in the “ground loop” between the object and site’s verified ground is 10  $\Omega$  or less for the duration of the process.

If the ground connection resistance is higher than 10  $\Omega$  the indicator will not go green. This could be evidence of wire connections loosening, breaking or product deposits, and paint coatings impeding a reliable electric connection to the equipment.

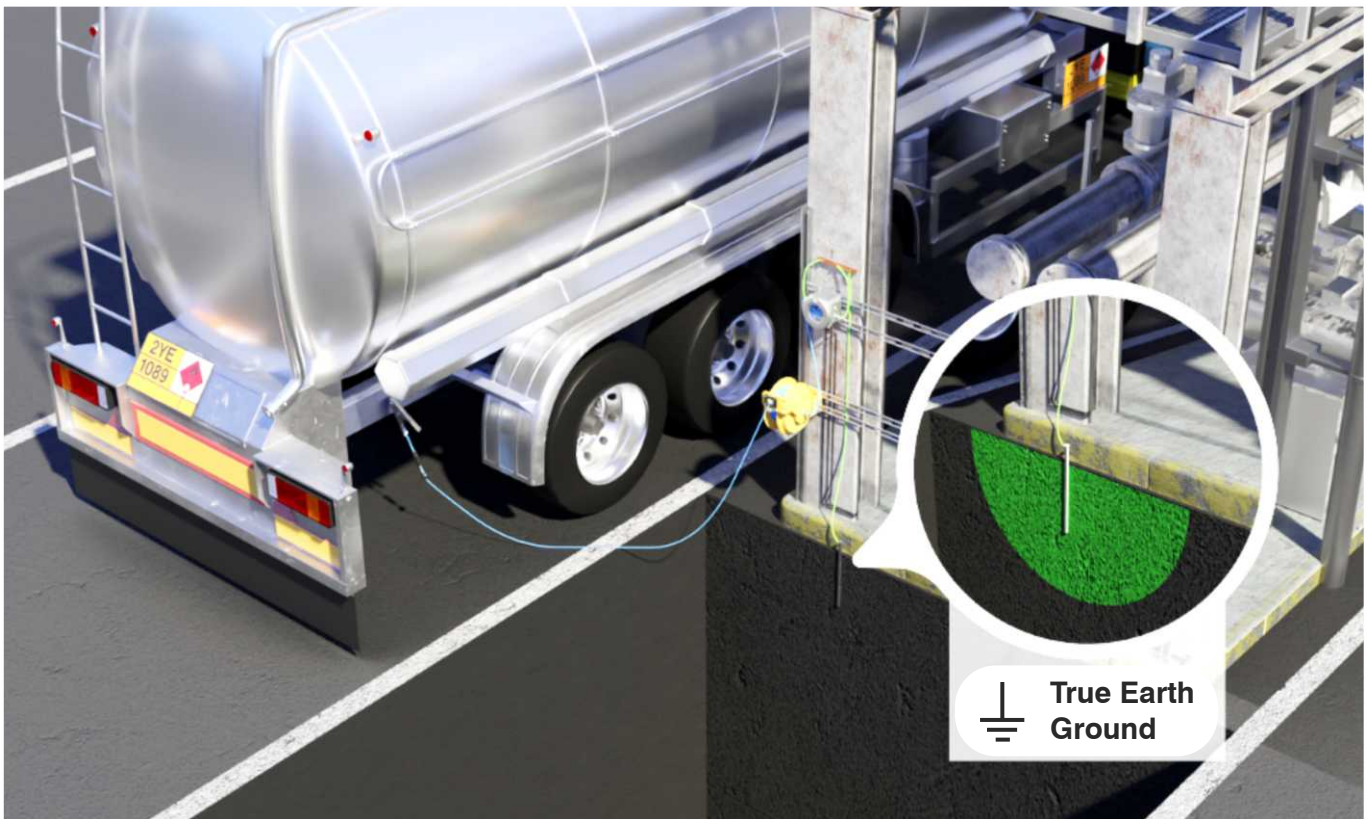
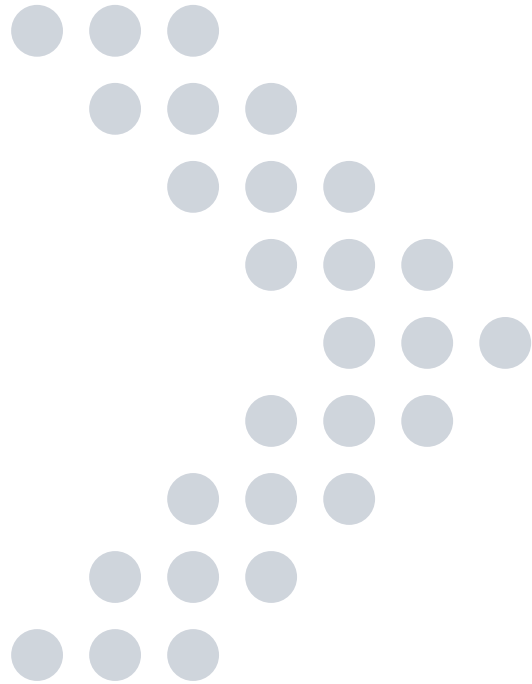

An Earth-Rite® II RTR system, with visual indication, grounds a road tanker to true earth.

## 1

## Applications

Although there are numerous processes at risk of charge generation to discuss, this Grounding & Bonding Handbook provides a general overview of some of the processes referred to in **IEC TS 60079-32-1** and **NFPA 77** and further information on static electricity as a potential ignition source.

## 2

## Operator Training

As operators will, for the majority of applications, be the people responsible for grounding or bonding equipment, it is essential that:

- a) They are trained to understand why static electricity can pose an ignition risk for day-to-day operations.
- b) They are trained on the correct use of static control equipment.

To do neither heightens the likelihood that they will not understand the inherent risks associated with electrostatic discharges. If the process characteristics permit it, the principle of “Clamp On First, Clamp Off Last” can be embedded in the static grounding SOP.

## 3

## Installation

There is no point in specifying Ex certified systems only for them to not be installed in accordance with the manufacturer’s instruction manual. Installations that do not reflect the manufacturer’s instruction manual risk invalidating the system’s certificate and use. It is essential that the site owner or electrical contractor ensure that the installer has the appropriate competency level to install equipment certified for installation and use in a hazardous area. From a certification standpoint, the instruction manual is a controlled document that will have been approved by the 3rd party certification body and should be reviewed before the installation begins. Under no circumstances should the installation be attempted without first consulting the manufacturer’s instruction manual.



## 4

## Interlocks

In combination with visual indication, grounding systems with output contacts can be utilised to add an extra layer of control. Such systems, normally incorporating voltage free contacts (dry contacts) or intrinsically safe contacts, can be used to provide a permissive condition to equipment like pumps or PLCs when the grounding system input requirement (e.g.  $R \leq 10 \Omega$  resistance is established) is met. This helps site managers to promote a policy of “Clamp on First, Off Last” with respect to static grounding SOPs such that the process will not begin unless the grounding system has the necessary input(s) to provide a permissive output condition to the equipment controlling the movement of product.

## 5

## Certification

It is essential that the **hazardous area zoning classification (ATEX/IECEx)**, or **Class and Division (North America)**, details of the location into which the equipment will be installed and operated is fully known prior to specifying static control equipment. This ensures that the equipment protection techniques designed into the grounding system are 3rd party certified for use in that area.

# CONTROLLING THE RISK OF ELECTROSTATIC IGNITIONS IN Ex/HAZLOC OPERATIONS

This article is designed to aid engineers, operations managers and safety professionals in understanding the root causes of static electricity and why it can be a potential ignition source in daily operations.

The article will also provide a general overview of legislation and industry guidance relevant to static electricity and then outline practical methods around how it can be managed.

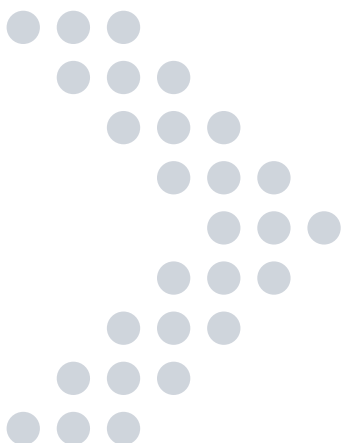

## Static as an Ignition Source

Static electricity is just one of several sources of ignition regularly identified as being responsible for the ignition of combustible atmospheres (gas and/or dust) and there are a range of site wide operations that can result in the generation of static electricity. Whether the operation involves filling, dispensing flammables or conveying/tipping powders into vessels, static electricity can be generated just through the movement of the material being processed or handled.

Because static electricity has long been known to present an ignition source in hazardous area operations, it is highlighted in legislation.

High levels of safety awareness in the intermediate and specialty chemical industry have been in place for decades and the management and mitigation of ignition source risk has always been a major practice for safety professionals, operations managers and engineers.

In Annex II of the ATEX Directive 2014/34/EU it states the following:

### Section 1.3.2 “Hazards arising from static electricity”

- “Electrostatic charges capable of resulting in dangerous discharges must be prevented by means of appropriate measures.”

In carrying out the obligations laid down in **Articles 6 and 9 of Directive 89/391/EEC** the employer shall assess the specific risks arising from explosive atmospheres, taking account at least of:

- “the likelihood that explosive atmospheres will occur and their persistence,
- the likelihood that ignition sources, including electrostatic discharges, will be present and become active and effective,
- the installations, substances used, processes, and their possible interactions,
- the scale of the anticipated effects.”

Explosion risks shall be assessed overall.

## Getting to grips with Static Electricity

Although it is easy to understand why static electricity can be perceived as a mysterious topic to get to grips with, the principles around which static electricity can present an ignition source risk are relatively straightforward.

One common denominator is the interaction of electrically insulating materials (materials that have a low conductivity, e.g., toluene) with electrically conductive materials (e.g., plant equipment constructed from metals).

When an insulating material like toluene comes into contact with metal plant equipment, whether it's flowing in piping, through a filter or being deposited into a drum, the toluene attracts electrons from the metal surface of the equipment it is in dynamic contact with.

The net result of this interaction is that the toluene is rapidly building a negative electrical charge, as it is attracting negatively charged electrons from the conductive metal, while the metal equipment is rapidly building a positive electrical charge.

The problem with this situation, if it is allowed to continue, is that the voltage of both materials will rise rapidly if both materials are "isolated" from the earth.

The problem with this scenario is that the voltage of the drum will rise based on the amount of negative charge residing on its outer surface relative to its own value of capacitance.

The more charge, the higher the voltage. **This scenario can be best explained through the formula:**

$$V = \frac{Q}{C}$$

**Where:**

V = voltage of charged object (Volts)

Q = total quantity of charge on the object (Coulombs)

C = capacitance of charged object (Farad)

(Source: NFPA 77: 6.3.1)

As more charge is deposited on the isolated object there is a constant voltage rise. In our example, this is the outside surface of the drum as it is being filled with the toluene.

As the voltage rapidly rises and the electrical field strength around the surface of the drum passes 3000 volts per millimeter (the breakdown voltage of air at ambient conditions) then there is a real risk that an electrostatic spark will be discharged from the surface of the drum into the potentially combustible atmosphere. In order to initiate combustion of the atmosphere, assuming it is within its ignitable range, the energy of the resulting spark must exceed the minimum ignition energy (MIE) of the surrounding flammable atmosphere.

Any object isolated from the earth can be described as possessing an "electrical capacitance" which is denoted with the symbol "C" and is measured in Farads.

If we take the example of the toluene building a continuous negative charge as it flows through the metal piping system and gets deposited into an object like a metal drum which is isolated from earth, the drum will build a negative charge on its outside surface. The reason for this is that the negative voltage of the toluene forces the electrons in the drum to the outside surface of the drum. This is caused by the "rule-of-thumb" principle that like charges repel and unlike charges attract.

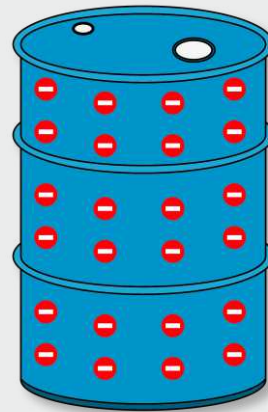

Negative electrical charges distributed on external surface.

**The potential energy of an electrostatic spark discharge can be illustrated in the formula:**

$$W = 0.5CV^2$$

**Where:**

W = spark energy (joules)

C = capacitance of isolated object (farad)

V = voltage of isolated objects (volts)

(Source: NFPA 77: 6.9.1)

If it is assumed that the voltage of the object has exceeded the breakdown voltage of the surrounding atmosphere and is charged to a voltage of, say, 10,000 volts at the moment when there is a spark discharge to another object in close proximity to the drum, the potential energy of the resulting spark would be approximately 2.5 mJ. This assumes the drum has a minimum capacitance of 50 pF as indicated in Table 2. If we are assuming that the flammable mixture surrounding the drum is a toluene-air vapour the minimum ignition energy would be in the region of 0.24 mJ (Source: **Table B1 of NFPA 77 "Recommended Practice on Static Electricity" (2024)**) then the resulting energy from the spark would be capable of initiating combustion of the vapour.

Charge generation is not just limited to liquids. Powder processing operations can produce electrostatic charging rates well in excess of liquids and gases.

Static accumulating liquids	Static accumulating powders
Benzene	PTFE
Diesel	Polyethylene
Gasoline	PMMA
Light crude	Wood
Crude/Gas condensates	Polyurethane
Jet fuel	PVC
Kerosene	Pyrex
Toluene	Neoprene
Xylene	Nylon
Hexane	Polypropylene
Heptane	Polystyrene

Table 1: Examples of static accumulating materials

Value of capacitances for typical conductors	
Object	Capacitance pF*
Small metal items (scoop, hose nozzle)	10 to 20
Small containers (bucket, 50 l drum)	10 to 100
Medium containers (250 l to 500 l)	50 to 300
Major plant items (reaction vessels) immediately surrounded by earthed structure	100 to 1000
Human body	100 to 200
*1 pF = 1 x 10 <sup>-12</sup> F	

Table 2: Capacitance of objects routinely used in the movement and containment of hazardous products. (Source: IEC TS 60079-32-1 “Explosive atmospheres, Part 32-1: Electrostatic hazards, guidance” – Table A.2)



Charge build up on powders	
Operation	Mass charge density (µC kg <sup>-1</sup> )
Triboelectrical powder coating	10 000 to 1 000
Pneumatic conveying	1 000 to 0.1
Micronizing	100 to 0.1
Grinding	1 to 0.1
Scroll feed transfer	1 to 0.01
Pouring	1 to 0.001
Sieving	0.001 to 0.000 01

Table 3: Charge build up on powders through different processing techniques and the quantity of charge typically carried per kilogram of powder. (Source: CLC/TR 60079-32-1 “Explosive atmospheres, Part 32-1: Electrostatic hazards, guidance” – Table A.1).

Objects	What causes capacitance?
Portable drums	Protective coatings, product deposits, rust
Road tankers	Rubber tyres
Piping	Rubber and plastic seals, anti-vibration pads and gaskets
Railer tankers	Grease, vibration pads isolating tank from rail cars. Rails isolated from loading gantry
People	Soles of footwear
Scoops	Rubber gloves
Hoses	Broken internal helixes and bonding connectors
FIBC	Non-conductive fabric / damaged static dissipative threads

Table 4: Examples of why process equipment and people can be isolated from earth.



Bulk Material Transfer



Ex IBC and Drum Filling



FIBC Type C Bag Powder Filling



Railcar Grounding

## Processes capable of generating Static Electricity

In the intermediate and specialty chemicals sector there are many processes that can result in the generation of static electricity as a natural by-product of the process in question. Such examples include but are not limited to:

- Bulk material transfer into or out of **road tankers and railcars**.
- **Ex IBC and drums** that are being filled, emptied, or being used as mixing and blending vessels.
- Transferring liquids and powders via hoses.
- Filling or emptying vessels and **FIBC with powders**.
- Even people, if they are wearing **insulating footwear** or are walking on insulating surfaces, can accumulate large voltages on their body without even sensing it.

However, the vast majority of these situations can be managed by ensuring the objects at risk of static charge accumulation are not isolated from earth. Because fixed plant like large storage tanks and vessels should be earthed via the plant structure, the risk of static spark discharges is most pronounced for moveable objects ranging from road tankers to people.

**Table 4** highlights some of the sources of electrical isolation on moveable equipment. If the objects are connected to earth then the charge imbalance on the object is neutralised which mitigates the risk of a static spark with enough energy to ignite potentially combustible atmospheres.

Sole-Mate™ II  
static dissipative  
footwear testing





## Grounding and Bonding Systems

Grounding potentially isolated equipment should be regarded as a compulsory safety function in any process and area where combustible products are handled and processed. It is the most practical and effective way of mitigating the accumulation of static electricity on equipment (and people). However, having objects in contact with ground is not grounding. For example, resting a drum on concrete or using drag chains on road tankers does not provide an effective and reliable means of preventing static charge accumulation.

### So what does “grounding” really mean?

In effect, if we can connect our potentially isolated equipment to a verified “true earth ground” i.e. a connection to the general mass of the earth that has been measured and verified to be below 10 Ω, in accordance with a standard like the **EN 62305** standard for grounding lightning protection systems, we can be confident that connecting to installed ground networks like the local lightning and electrical grounding protection system will enable static charges to dissipate safely from the process equipment. The busbar network that feeds out from the ground rods (installed ground network) can provide a means of grounding our process equipment.

Bonding is different to grounding in that it ensures that two bonded objects at risk of static charge accumulation are at the same electrical potential, however, it does not mean they have no charge, i.e. are at ground potential (0 volts). Bonding ensures there is no risk of static spark discharges between the bonded objects. It does not mean they are not capable of discharging sparks to objects at a lower electrical potential.

For movable metal objects this extract from **IEC TS 60079-32-1 “Explosive atmospheres, Electrostatic hazards, guidance”** recommends the following:

#### Section 13.4 “The establishment and monitoring of grounding systems”:

##### 13.4.1 Design

“Permanent bonding or earthing connections should be made in a way to provide low resistance during its lifetime, e.g. by brazing or welding. Temporary connections can be made using bolts, pressure-type earth clamps, or other special clamps. Pressure-type clamps should have sufficient pressure to penetrate any protective coating, rust, or spilled material to ensure contact with the base metal with an interface resistance of less than 10 Ω.”

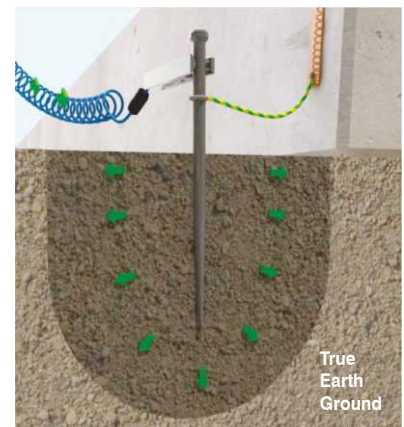

“True Earth Ground”  
- a connection to the general mass of the earth that has been measured and verified to be below 10 Ω.

A resistance of 10 Ω or less refers to the resistance between the object requiring static grounding protection and the local ground network.

Any resistance higher than this value would indicate loose connections or corrosion (see reference to NFPA 77, Section 7.3.1.6.1) which could limit the dissipation of electrostatic charges from the equipment undergoing electrification. The challenge, however, is to ensure we implement a consistent and reliable means of connecting to these networks, especially since most of the equipment we are dealing with is portable and will not have a permanent connection to the site’s local ground network.

#### Section 7.3.1.6.1 of NFPA 77, “Recommended Practice on Static Electricity”

“Where the bonding/grounding system is all metal, resistance in continuous ground paths is measured to verify mechanical integrity. (See A.3.3.2.) \* Such systems include those having multiple components. Greater resistance usually indicates that the metal path is not continuous, usually because of loose connections or corrosion.....”

\* A.3.3.2 Bonding.

A resistance not exceeding 10 ohms for copper wire or 25 ohms for stainless steel or other metals is typically found in practice. Higher resistances could indicate a lack of mechanical integrity.

## Implementing Practical Grounding Solutions

The implementation of a consistent and repeatable way of grounding mobile equipment needs to take into account the characteristics of the process, who the responsible people are for performing the grounding and bonding safety function on a daily basis and other factors like environmental conditions and the classification of the hazardous area.

Whatever method is adopted, it is critical to ensure that the person (people) responsible for performing the safety function of grounding equipment understand the importance of doing it, and, that the grounding activity itself is kept relatively simple. There are many cases where sites with good grounding practices have been caught out either due to forgetfulness on the part of an operator, or, because a minor flaw in the process has been missed.



## Industrial Grade Grounding Clamps

Grounding clamps are the most “traditional” means of connecting mobile plant equipment to verified grounding points. However, equipment specifiers need to be aware of the difference between clamps like alligator clips as compared with static grounding clamps that have been designed for repeated use in harsh industrial environments.

Clamps like alligator clips are designed to be attached to clean surfaces like battery terminals. They are not designed to penetrate industrial grade protective coatings or product deposits on equipment that would otherwise not permit static charges to pass through them. So even though the clamp may be attached to the object, it does not mean it is effectively grounding it.

Clamps that combine a strong spring pressure with sharp rugged teeth have a greater chance of penetrating surfaces that would otherwise prevent a reliable electrical and mechanical connection to the equipment which may become electrostatically charged.

Clamps that carry the **FM approval** mark will have passed a range of functional tests that demonstrate key functional performance characteristics to operate successfully.

These tests include:

- Clamp pressure testing
- Pull resistance testing
- Electrical continuity testing (less than 1  $\Omega$  through the clamp itself)
- Clamp connection testing in response to a range of vibrating frequencies.



Bond-Rite®  
Ground circuit monitoring units

Although the use of a basic (passive) grounding clamp may not verify a low resistance connection to equipment for the operator, selecting a grounding clamp that combines FM approval with a set of sharp teeth capable of penetrating layers that would otherwise inhibit static charge transfer, will enhance the likelihood of repeatable and reliable ground connections to plant equipment.

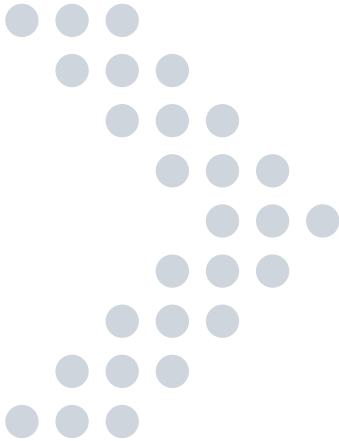

## Verifying a Positive Ground Connection

Combining certified grounding clamps with a ground monitoring system adds the benefit of providing positive confirmation to operators that a 10 Ω or less connection to the plant equipment requiring static grounding protection has been achieved after they have attached the grounding clamp. This effectively removes the “guesswork” out of knowing whether or not the equipment is grounded. Once a connection of 10 Ω or less has been verified by the system, an indicator like a flashing green LED will let the operator know that they can proceed with the operation (e.g., filling or mixing operation).

The benefit of the flashing green LED principle is that it lets people in the area know that the system is continuously monitoring the health and effectiveness of the grounding circuit and that should the resistance rise above 10 Ω, or the clamp’s connection to the equipment be compromised in any way, that the LED will switch off. This will notify people working in the area that the process should be halted, or if it cannot be halted, that the equipment should not be approached until an adequate charge relaxation time period has been adhered to after the process has finished.



Earth-Rite® II RTR monitoring unit with interlock capabilities

The use of a ground circuit monitoring system with an indicator has the added benefit of becoming a core step in the operator’s Standard Operating Procedures (SOP) so that if the green light is not obtained the process should not begin. It also enhances the site’s ability to demonstrate compliance with the recommendations of **IEC TS 60079-32-1** and **NFPA 77** by ensuring the process does not start unless a verified 10 Ω or less connection has been achieved.



Earth-Rite®  
MULTIPOINT II  
monitoring unit with  
interlock capabilities

## Ground Verification with Interlocks

If the process that causes charge generation is automated, an alternative option is to specify a **grounding system** that will not only verify and indicate a ground connection resistance of 10  $\Omega$  or less, but through its volt free contacts, control the process (e.g. **road tanker loading operation**).

Unless the grounding system detects a 10  $\Omega$  or less connection it will not permit the process to begin.

It should be noted that when the grounding system is interlocked with equipment controlling material flow, the device moving the material (e.g., a pump) may stop, but the actual flow or movement of material may continue for a short period afterward - for example, if a clamp is accidentally removed mid-transfer.

It is the responsibility of the customer to determine what measures need to be in place to manage scenarios where static charge could still be present. Likewise, if the clamp's connection or the grounding circuit should be compromised during the process, the grounding system will automatically detect this situation and halt the process, thereby stopping the further generation and accumulation of static electricity on the process equipment.

The benefit of this type of system is that it really enforces the Standard Operating Procedures (SOP) of grounding the object prior to process initiation.

Again, what needs to be borne in mind is that the person tasked with ensuring the safety function of grounding the equipment is actioned via an easy and repeatable way of grounding the equipment. The most effective way of getting acceptance and engagement from the operator is to keep the visual indication and mode of operation as simple as possible. A simple red "NO-GO", and a flashing green "GO" method of visual indication is a simple but effective concept for people to engage with.

This, in line with a simple action of connecting the grounding clamp to the object requiring grounding, without any additional need to interface with switches and dials, simplifies the procedure.

# SPECIFICATION OF HAZARDOUS AREA CERTIFIED EQUIPMENT

When specifying equipment intended for use in a potentially explosive atmosphere (Ex atmosphere) it is important to determine what the hazardous area classification of the location is prior to engaging in the search. This is so equipment with the appropriate level of Ex certification can be selected for installation, regular maintenance and safe operation over its service lifetime.

As it is not possible to provide an in-depth review of the clauses in the standards referenced below, only certain aspects will be highlighted.

If you are in any doubt with respect to your obligations as a specifier, installer, inspector, or maintainer of Ex certified equipment please discuss with a competent person or authority. As the sole manufacturer and Ex certificate holder of Newson Gale hazardous area certified static grounding equipment our team of CompEx certified engineers can support customers with any detailed questions they may have with respect to the Ex certification of our static grounding systems, associated Instruction Manuals and the hazardous areas in which the Ex equipment can be installed and used.



## Standards Referenced:

### **BS EN 60079-14 / IEC 60079-14**

“Explosive atmospheres – Electrical installations design, selection and erection”

### **BS EN ISO 80079-20-1 / ISO/IEC 80079-20-1**

“Explosive atmospheres – Material characteristics for gas and vapour calculation. Test methods and data”

### **BS EN ISO 80079-20-2 / ISO/IEC 80079-20-2**

“Explosive atmospheres – Material characteristics. Combustible dusts test methods”

### **BS EN IEC 60079-10-1 / IEC 60079-10-1**

“Explosive atmospheres – Classification of areas – Explosive gas atmospheres”

### **BS EN IEC 60079-10-2 / IEC 60079-10-2**

“Explosive atmospheres – Classification of areas – Explosive dust atmospheres”

### **BS EN 60079-7 / IEC 60079-7**

“Explosive atmospheres – Equipment protection by increased safety “e”

### **BS EN 60079-11 / IEC 60079-11**

“Explosive atmospheres – Equipment protection by intrinsic safety “i”

\* Notes on standards referenced are located at the end of this article.



All our products comes with a manufacturer's Instruction Manual.

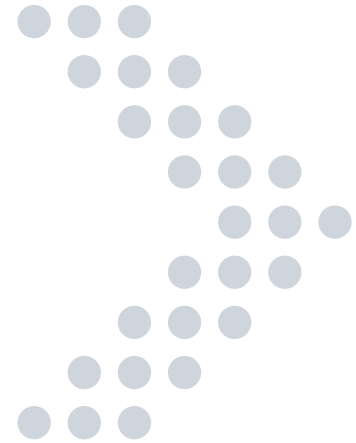

## Selection of Ex Equipment

**BS EN 60079-14 / IEC 60079-14** “Electrical installations design, selection and erection” contains the “*specific requirements for the design, selection, erection and initial inspection of electrical installations in, or associated with, explosive atmospheres*”.

Selection of Ex certified equipment is not just limited to the material classification and zoning of the atmospheres in which the equipment will be installed and used.

In reference to clause 7 of **IEC 60079-14** the following criteria must be defined and known prior to equipment selection:

- The classification of the hazardous area and the associated EPLs\*.
- The classification of the gas, vapour or dust group and subgroups.
- The temperature class or ignition temperature of the gas or vapour.
- The minimum ignition temperature (MIT) of the dust cloud and MIT of the dust layer.
- The intended application of the equipment.
- The ambient temperature range and potential external influences.

As a manufacturer of Ex certified equipment, our quality management systems are audited on an annual basis for compliance with **ISO 9001**, and, more specifically, the subset of **ISO 9001** that applies to quality management systems for the manufacture of Ex certified products, **ISO/IEC 80079-34:2018**, “**Explosive atmospheres – Part 34: Application of quality management systems for Ex Product manufacture.**”

## Competency of Individuals

It should be borne in mind that persons tasked with designing, selecting and erecting Ex equipment should be competent in these activities. **Annex A.2** of **BS EN 60079-14 / IEC 60079-14** states that persons engaged in such activities should possess:

- Understanding of the general principles of explosion protection;
- Understanding/knowledge of those aspects of equipment design which affect the protection concept;
- Understanding of certification documents;
- Familiarity with the particular techniques to be employed in the selection and installation/erection of equipment;
- Familiarity with the practical skills for the preparation and installation of relevant concepts of protection;

More specific competencies are described depending on people's roles. For example, the competencies of persons designing installations, and selecting the EX equipment to operate in such installations, are different to those who may be operating the Ex equipment or providing inspection or maintenance services.

### **Annex A.4 “Competency Assessments” states:**

*“Competency of individuals shall be verified and attributed on the basis on sufficient evidence that the person:*

- *have the necessary skills required for the scope of work*
- *connect competently across the specified range of activities*
- *have the relevant skills supporting competency.*

More detailed requirements for specific roles are outlined in the rest of this Annex.

## Documentation

The installation of Ex equipment must comply with the manufacturer's equipment certificate and documentation. This information is usually provided in the manufacturer's Instruction Manual. In accordance with **Clause 5.1 of IEC 60079-14** a "verification dossier" needs to be kept for each installation.

The verification dossier should contain the following information. (Please note that the following list is non-exhaustive and only applies to certain clauses in the standard).

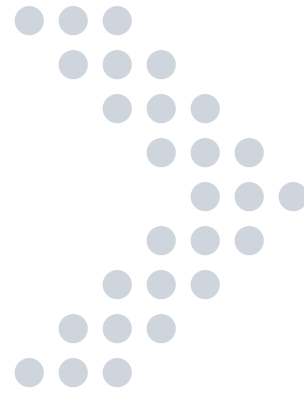

### 1

#### For the site:

- area classification documents (see **IEC 60079-10-1 and IEC 60079-10-2**) with plans showing the classification and extent of the hazardous areas including the zoning (and maximum permissible dust layer thickness if the hazard is due to dust);
- optional assessment of consequences of ignition (see 5.3\*);
- where applicable, gas, vapour or dust classification in relation to the group or subgroup of the electrical equipment;
- temperature class or ignition temperature of the gas or vapour involved;
- where applicable, the material characteristics including electrical resistivity, the minimum ignition temperature of the dust cloud, minimum ignition temperature of the dust layer and minimum ignition energy of the dust cloud;
- external influences and ambient temperature (see 5.9).

\* Note: 5.3\* references EPLs for specific zones as described in Tables 1 and 2.

### 2

#### For the Ex equipment:

- manufacturer's instructions for selection, installation and initial inspection;
- documents for electrical equipment with conditions of use, e.g. for equipment with certificate numbers which have the suffix "X";
- descriptive system document for the intrinsically safe system (see 16.2.4.2);
- details of any relevant calculation, e.g. for purging rates for instruments or analyser houses;
- manufacturer's/qualified person's declaration (see 4.4.2).

Consideration should be given to obtaining information for maintenance and repair to meet the requirements of IEC 60079-17 and IEC 60079-19 respectively.



If you choose to specify a Newson Gale static control solution, regardless of where you are in the world, our sales team/s and CompEx® engineers will support you with any pre-sales or post-sales queries you may have ranging from the Ex certification details of our products, support with installation and operating instructions and any technical post installation questions you may have.

## Material Groups and Equivalent Equipment Markings

Hazardous areas should be classified into groups and zones. This enables the specification of Ex certified equipment that matches the EPLs required for the zoning of the area in which that material is likely to produce an explosive atmosphere.

In accordance **BS EN ISO 80079-20-1 / IEC 80079-20-1** “**Material characteristics for gas and vapour calculation – Test methods and data**”, gas and vapour atmospheres are defined as Group II materials that are subdivided in relation to their Maximum Experimental Safe Gap (MESG) and Auto Ignition Temperature (AIT) characteristics. These subdivisions are defined as (including examples):

- IIA (butane, heptane, ethyl acetate)
- IIB (ethylene, ethanol, dibutyl ether)
- IIC (hydrogen, acetylene, carbon disulphide)

Electrical equipment intended for use in explosive gas and vapour atmospheres are classed as Group II. Equipment marked:

- IIA can only be used in IIA gas/vapour atmospheres
- IIB can only be used in IIA and IIB gas/vapour atmospheres
- IIC can be used in all gas/vapour atmospheres

Based on **BS EN ISO 80079-20-2 / IEC 80079-20-2** “**Material characteristics - Combustible dusts test methods**” combustible dust materials are categorised as Group III and subdivided into:

- IIIA combustible flyings
- IIIB non-conductive dust
- IIIC conductive dust

Electrical equipment intended for use in explosive dust atmospheres are classed as Group III. Equipment marked with:

- IIIA can only be used in IIIA atmospheres
- IIIB can be used in IIIB and IIIA dust atmospheres
- IIIC can be used in any dust atmosphere

Group I equipment is intended for use in mining and, as such, is not relevant to Newson Gale's customers.

## Hazardous Area Zoning and Associated Equipment Protection Levels (EPLs)

Hazardous area zones are classified based on the following standards which define the methods by which the type and extent of the zones can be established for a particular location.

- **BS EN IEC 60079-10-1 / IEC 60079-10-1** “**Classification of areas – Explosive gas atmospheres**”.
- **BS EN IEC 60079-10-2 / IEC 60079-10-2** “**Classification of areas – Explosive dust atmospheres**”.

Areas of the plant where explosive atmospheres are not expected to form or be present are classified as “non-hazardous”.

The EPLs of Ex equipment operating in explosive atmospheres are described in **EN IEC 60079-0** “**Equipment – General requirements**”. This standard “**specifies the general requirements for construction, testing and marking of Ex Equipment and Ex Components intended for use in explosive atmospheres**”.

### 3

**Different types of protection are designed to meet the EPLs of specific zones.** The levels of protection are based on preventing ignition of the surrounding atmosphere due to the likelihood of the equipment becoming an ignition source.

Sub-parts of the **EN/IEC 60079-0** standard provide the detailed requirements for each specific type of protection. For example, protection by intrinsic safety, a method that limits the energy of electrical circuits, thereby reducing the potential for sparking or heating to ignite an explosive atmosphere, is detailed in **BS EN 60079-11 / IEC 60079-11** “**Equipment protection by intrinsic safety “I”**”.

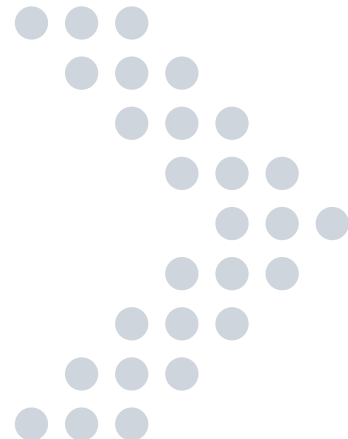

**Gas/Vapour Zones are defined as:**

Zone Classification	Definition in BS EN 60079-14	Definition in IEC 60079-14	Equipment Protection Levels	Protection by Intrinsic Safety
Zone 0	Place in which an explosive atmosphere consisting of a mixture with air of flammable substances in the form of a gas or vapour is present continuously or for long periods or frequently.	Area in which an explosive gas atmosphere is present continuously, or for long periods, or frequently.	“Ga”	“ia”
Zone 1	Place in which an explosive atmosphere consisting of a mixture with air of flammable substances in the form of a gas or vapour is likely to occur in normal operation occasionally.	Area in which an explosive gas atmosphere is likely to occur occasionally in normal operation.	“Ga” or “Gb”	“ia” or “ib”
Zone 2	Place in which an explosive atmosphere consisting of a mixture with air of flammable substances in the form of a gas or vapour is not likely to occur in normal operation but, if it does occur, will persist for a short period only.	Area in which an explosive gas atmosphere is not likely to occur in normal operation but if it does occur, will persist for a short period only.	“Ga” or “Gb” or “Gc”	“ia” or “ib” or “ic”

Table 1: Comparing Gas or Vapour Zones with designated EPLs and a protection type (intrinsic safety in this example) that are specified to achieve a particular EPL.

**Dust Zones are defined as:**

Zone Classification	Definition in BS EN 60079-14	Definition in IEC 60079-14	Equipment Protection Levels	Protection by Intrinsic Safety
Zone 20	Area in which an explosive atmosphere in the form of a cloud of dust in air is present continuously, or for long periods or frequently.	Area in which an explosive atmosphere in the form of a cloud of combustible dust in air is present continuously, or for long periods or frequently.	“Da”	“ta”
Zone 21	Area in which an explosive atmosphere in the form of a cloud of dust in air is likely to occur, occasionally, in normal operation.	Area in which an explosive atmosphere in the form of a cloud of combustible dust in air is likely to occur, occasionally, in normal operation.	“Da” or “Db”	“ta” or “tb”
Zone 22	Area in which an explosive atmosphere in the form of a cloud of dust in air is not likely to occur in normal operation but, if it does occur, will persist for a short period only.	Area in which an explosive atmosphere in the form of a cloud of combustible dust in air is not likely to occur in normal operation but, if it does occur, will persist for a short period only.	“Da” or “Db” or “Dc”	“ta” or “tb” or “tc”

Table 2: Comparing Gas or Vapour Zones with designated EPLs and a protection type (intrinsic safety in this example) that are specified to achieve a particular EPL.



Earth-Rite® systems, such as the **Earth-Rite® RTR road tanker grounding system**, do not require calibration during their lifetime. However, operator parameters can be tested to verify performance.



## Combinations of Protection Concepts

The techniques described in **EN/IEC 60079**, can be combined to achieve a desired set of outcomes. This combination of techniques must be assessed as a single system described as “Ex Equipment”. Assuming the product passes the necessary set of design and testing standards carried out by a notified body (for **ATEX**) and/or an **ExCB** (for **IECEX**) the products will be marked with the details that enable the specifier to match the product with appropriate hazardous area classification details.

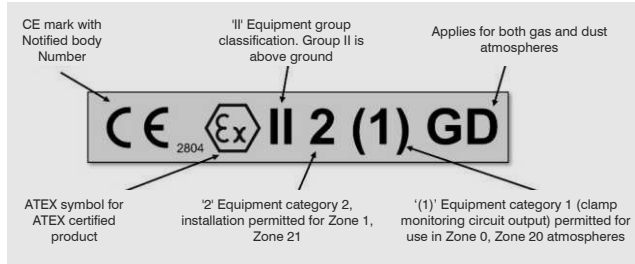

Fig.1: ATEX equipment marking

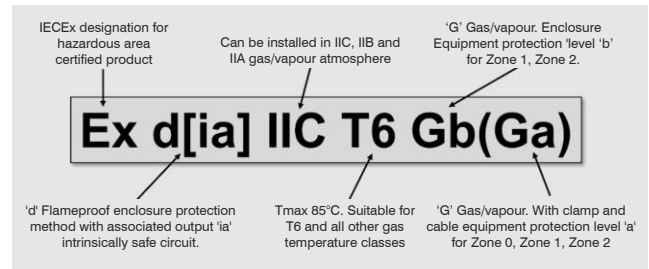

Fig.2: IECEx equipment marking (gas/vapour atmospheres)

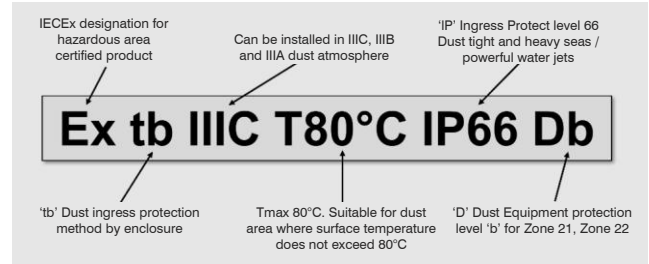

Fig.3: IECEx equipment marking (dust atmospheres)

## Is one equipment protection concept better than another?

Although harmonised standards are designed to promote compliance with the EHSRs (Essential Health & Safety Requirements) of the relevant legislation, some Ex equipment manufacturers claim that systems which combine different protection concepts can possess certain technical advantages over other manufacturer's equipment.

### Examples:

- Some installers believe that Ex d flameproof enclosures take a long time to install because they need to be fitted with compound filled/barrierised glands\*. This may not be the case depending on the gas group, the cable construction and length and also if the Ex d flameproof enclosure's internal volume is less than two cubic litres. The majority of Newson Gale's range of Ex d enclosures are less than 2 litres internal capacity therefore standard Ex d glands may be possible to install in gas atmospheres in accordance with IEC 60079-14.
- Some manufacturers promote the idea that using a protection concept quartz filled or encapsulation has the added benefit of protecting PCB components from electronic damage caused by personnel discharging static from their body during installation. To begin with, any installer competent enough to work in an Ex area should be wearing static dissipative shoes to prevent their bodies providing a potential source of ignition through a static spark discharge. A potential disadvantage of compound filling is inaccessibility to the PCB if there is a need to repair or replace the PCB or components on the PCB that are covered by the hardened compound. In such cases the whole system may need to be scrapped.
- Where a concept like intrinsic safety (**BS EN 60079-11 / IEC 60079-11**), is combined with increased safety (**BS EN 60079-7 / IEC 60079-7**), it is possible to perform live maintenance on the Ex equipment for a “short period”, provided the manufacturer's instructions permit it. Live maintenance would suggest that the enclosure can be opened in a classified area, however the “short period” of time is not defined in the relevant clause (4.10.3) of the increased safety standard. This could be a useful feature for maintenance staff if, for example, the Ex equipment requires immediate attention but this feature should not be a substitute for systems that require regular attention to rectify reliability or performance issues. Aside from the risk attached to the contents of the enclosure being exposed to a classified area for an undefined period of time, protection from electric shock due to the presence of live non-intrinsically safe circuits is also a factor that needs to be addressed.

\* When installed in accordance with **EN IEC 60079-14** compound filled/barrier cable glands may not be required.



IECEX



## Hybrid Atmospheres

Although rare, if hybrid atmospheres do exist in a process area special assistance should be sought. The presence of dust in a gas/vapour atmosphere can have the effect of altering characteristics, e.g., like lowering the minimum ignition temperature (MIT) of the dust cloud.

*“While the essential legal requirements in GB remain the same as the equivalent EU law, the informative Annex ZA/ZZ and any references to EU law in designated standards should be read as applying to the legislation for GB in the same way, subject to any restrictions or points made in the relevant notice of publication. This will change if and when the essential requirements in GB change. We have asked BSI to ensure that any new or revised designated standards map across to the essential requirements in GB.”*

[www.gov.uk/guidance/designated-standards#electric-and-electronic-engineering](http://www.gov.uk/guidance/designated-standards#electric-and-electronic-engineering)

In the area of Ex equipment standardisation, the IEC, on request from CENELEC, writes the standards that are deemed to meet the EHSRs of the ATEX equipment Directive 2014/34/EU. As such they get designated with the IEC description, e.g., IEC 60079-0 “Equipment – General requirements” when they are published by the IEC. When CENELEC publishes them as European Normative standards they are normally listed with EN in front of IEC, e.g., “EN IEC 60079-0”. The IEC runs its own Ex equipment certification scheme through IECEX. IECEX is a compulsory Ex certification requirement for some countries, e.g., Australia.

### Note on ATEX/IECEX/UKCA standards

The similarities and differences between ATEX, IECEX, and, following the UK’s withdrawal from the EU, UKCA, can be confusing.

CENELEC is the body which publishes EN standards that meet the **Essential Health & Safety Requirements (EHSRs)** mandated by the **European Commission** in the field of electrical technology. In the interests of driving common standards CENELEC works closely with the **International Electrotechnical Commission (IEC)** and the **International Standards Organization (ISO)**.



Testing static dissipative shoes before entering hazardous area



# WORLDWIDE DISTRIBUTION

Being recognised as the industry leader in hazardous area static control, our business and network of channel partners continues to grow.



With sales offices located in the UK, US, Germany and Singapore, in addition to our network of channel partners operating across Europe, the Middle East, India, Africa, South Korea, Australia, Mexico and Brazil, we can supply you with static control grounding solutions that carry the Ex/HAZLOC certification required by your local regulators.



Scan QR for  
contact details



# GROUNDING IN SAFETY, TRUSTED BY INDUSTRY

Static electricity is an ever-present and significant hazard for operations taking place in flammable, combustible or potentially explosive atmospheres. The uncontrolled buildup and discharge of electrostatic charge must be avoided in these environments to protect people, plant, processes and the environment.

**Newsom Gale's** wide range of static grounding solutions can control and mitigate these risks, creating a safer and more productive working environment.

[www.newsom-gale.co.uk](http://www.newsom-gale.co.uk)



**QUALITY  
ASSURANCE**



**INNOVATION IN  
STATIC CONTROL**



**TECHNICAL  
SUPPORT**



**GLOBAL  
DISTRIBUTION**

Please contact us on +44 (0)115 940 7500 so we can assist you with your application review and product selection.



**United Kingdom**  
Newsom Gale Ltd  
[newsom-gale.co.uk](http://newsom-gale.co.uk)

Omega House  
Private Road 8  
Colwick, Nottingham  
NG4 2JX, UK  
+44 (0)115 940 7500  
[groundit@newsom-gale.co.uk](mailto:groundit@newsom-gale.co.uk)

**United States**  
IEP Technologies, LLC  
[newsom-gale.com](http://newsom-gale.com)

417-1 South Street  
Marlborough  
MA 01752  
USA  
+1 732 961 7610  
[groundit@newsom-gale.com](mailto:groundit@newsom-gale.com)

**Deutschland**  
IEP Technologies GmbH  
[newsom-gale.de](http://newsom-gale.de)

Kaiserswerther Str. 85C  
40878 Ratingen  
Germany  
+49 (0)2102 5889 0  
[erdung@newsom-gale.de](mailto:erdung@newsom-gale.de)

## Copyright Notice

The document and its content is copyright of Newsom Gale Ltd © 2026. All rights reserved.

Any redistribution or reproduction of part or all of the contents in any form is prohibited other than the following:

- You may print or download to a local hard disk extracts for your personal and non-commercial use only.
- You may copy the content to individual third parties for their personal use, but only if you acknowledge the website as the source of the material.
- You may not, except with our express written permission, distribute or commercially exploit the content. Nor may you transmit it or store it in any other website or other form of electronic retrieval system.

## Right to change

This document provides general information only and may be subject to change at any time without notice. All information, representations, links or other messages may be changed by Newsom Gale at any time without prior notice or explanation.

Newsom Gale is not obliged to remove any outdated information from its content or to expressly mark it as being outdated. Please seek the advice of professionals as necessary regarding the evaluation of any content.

## Disclaimer of liability

The information provided in this Grounding & Bonding Handbook is provided by Newsom Gale without any representations or warranties, expressed or implied, as to its accuracy or completeness. The liability of Newsom Gale for any expenses, losses or actions incurred whatsoever by the recipient as a result of the use of this Grounding & Bonding Handbook shall be excluded.