



TT-316AC – Class-leading towing for manufacturing and warehousing.

VOLTAGE	36 volt
SPEED	8 mph / 12.8 km/h
RANGE	18 mi / 29 km
TURNING RADIUS	74.5 in / 189 cm
TOW CAPACITY	16,000 lb* / 7,250 kg*



SAFETY

- Automatic braking on gas pedal release and automatic parking brake
- Reverse beeper
- Operator presence sensor
- High visibility LED headlight, combination tail lights
- Optional high visibility light bar and pedestrian light for increased visibility



PERFORMANCE/ RELIABILITY

- AC efficient motor
- Regenerative braking
- Powerful GT drive
- All steel construction
- Taylor-Dunn Quality



COMFORT

- Tilt/Telescoping Steering
- Front and rear suspension
- Premium semi-suspension seat
- Rear deck storage area
- Low 10.5 in (26 cm) step height

PERFORMANCE

LOAD CAPACITY	400 lb / 182 kg
TOW CAPACITY	16,000 lb* / 7,257 kg*
DRAWBAR PULL	320 lb / 1.42 kN
MAX SPEED (UNLOADED)	8 mph / 12.8 km/h
TURNING RADIUS	74.5 in / 189 cm

DIMENSIONS

OVERALL LENGTH	83 in / 211 cm
OVERALL WIDTH	39.5 in / 100 cm
OVERALL HEIGHT	54 in / 138 cm
WHEEL BASE	55 in / 140 cm
DECK SIZE (W x L)	38 x 25 in / 96.5 x 63.5 cm
DECK HEIGHT	29 in / 74 cm

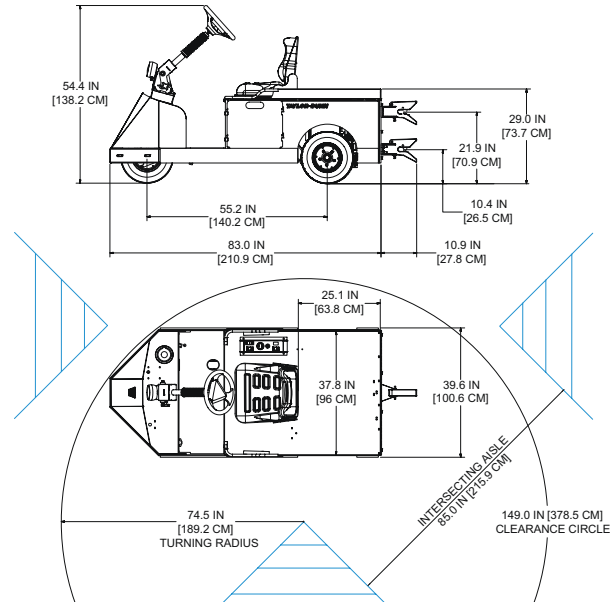

POWER SUPPLY / DRIVE TRAIN

MOTOR	7.5 HP AC
SYSTEM VOLTAGE	36 Volt
DRIVE AXLE	GT Automotive Differential
BATTERY	Less Battery, SBX 175 Gray, 38W x 16L x 15H in (96W x 40L x 38H cm)
CHARGER	Less Charger
CONTROLLER	450 Amp, 36 Volt, AC

CHASSIS

FRAME	Fully Welded, Unitized, 10 Gauge
STEERING	Tilt/Telescoping Gear Steering
SUSPENSION	Front Coil Springs, Rear Leaf Springs
BRAKES	3-Wheel Hydraulic Disc, Automatic/Electric Parking Brake
TIRES	4.80 x 8, Load Range C, Pneumatic

GENERAL

MAXIMUM OCCUPANCY	1 / 250 lb (113 kg)
UNIT WEIGHT	1,150 lb / 522 kg
SEAT	Single, Adjustable, Black Vinyl, with Spring Suspension, Electric Interlock Switch
INSTRUMENTATION	Smart View Display (Battery Status Indicator, Hour Meter, Fault Code Display) Forward/Reverse Selector, Key Switch, Electric Horn, Reverse Alarm, DC/DC Converter
LIGHT ACCESSORIES	LED Headlight, Taillight, Brake Light, Optional Light Bar with Reverse, Strobe and Brake Light
HITCH	Automatic Coupling
CONFORMANCE	Type E OSHA 1910.178, ANSI B56.9

OPTIONS

- Light bar
- Portable charger
- Blue pedestrian light
- Non-marking tires
- Roll-out or slide-out battery box
- Beacon or strobe light
- Automatic hitch w/ hand release
- Soft solid tires
- Various hitches
- Custom paint color
- Rubber bumper

WARRANTY

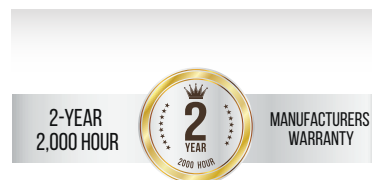

PROCUREMENT



* Based on Standard Configuration. Actual towing capacity is dependent on application, vehicle configuration, ballast weight, and operating environment. Note: Photos are shown with optional features. † Specifications, standard equipment, accessories and modifications are all subject to change without notice. Taylor-Dunn vehicles can be hazardous to operate and are not intended for on-road use. All riders should always wear safety protection as required for their jobsite and appropriate for operating conditions and intended usage, considering factors such as intended speed, unevenness of terrain, turns in path, vehicle traffic and other obstacles. Never engage in stunt driving, and avoid excessive speeds and sharp turns. Riding and alcohol/drugs don't mix. ©2019 Polaris Industries Inc.