



SATELLIET[®]
ORIGINALS



BE AN
ORIGINAL



Satelliet Originals is a European hospitality furniture collection with a distinctive character and a unique signature. Every product created by the Originals designers is edgy and embodies toughness, boldness, diversity and individuality. Satelliet Originals is not only an idiosyncratic label with a versatile collection, it also has a very diverse team of national and international designers behind it. In addition to individual customisation and originality, the eye, hand and heart of the designer, makes all the difference. Satelliet Originals design revolves around character, feeling, emotion and is characterised by a 'touch of hospitality'. Be an original is our core brand statement and stands for being yourself. Unapologetically.

Brand new.

Brand new Originals

11

Designers.

Jesse Visser	15
Erik Remmers	21
Elise Luttk	27
Jan Dijkstra	33
Lars Snellaars	41
Hofmeijer & Dekker	49
Studio Satelliet	53
Diederik Schneemann	79
BURO NOW	83
Jon + Sven	87
Frans Schrofer	91
Dave Keune	105
Gerard van den Berg	109
Ardie van Bommel	113
Tom Frencken	117
Originals Classics	121





About Originals.

Sustainability	7
Hospitality proof & tailor made	9
Designers	13

Collections.

Arcadia	17
Pebble	23
Chester	29
Cozito	35
Fioli	37
Olyn	39
ReUnited	43
Circl	47
25.25	51
Prim	55
Evora	59
Manado	61
Lux	63
Canu	65
Chantilly	67
Current	71
Gerlin	73
Code	75
Eclipse	77
Tube	81
Biscuit	85
Oso	89
Serpent	93
Loop	97
Orbit	99
Gelato	101
Mistral	103
Forge & Brewer	107
Montana	111
Ear	115
Legs	119
550 & S-17	121

BE SUSTAINABLE



'Waste isn't waste until we waste it.'

By continuously making sustainable decisions and deploy SUM - Still Usable Materials - for the creation of bespoke new products, we work hard on the future of sustainable hospitality furniture. At Satelliet Originals we strongly believe that contemporary and sustainable designs should be included in every

interior concept because of their distinctive, beautiful and comfortable characteristics. In doing so you unconsciously, yet consciously, contribute to a sustainable future, without compromising on quality and charisma. In striving for sustainability, beautiful collaborations emerge. Together we make a difference.

SUM Originals. Serpent, Code, Current, Press



Scan the QR code for more information.

BLE

**THE MOST
SUSTAINABLE
SUPPLIER OF
HOSPITALITY
FURNITURE
IN EUROPE
BY 2030**

MISSION HOSPITALITY
Ambition Satelli et hospitality furniture

HOSPITALITY PROOF TAILOR M



Touch of hospitality

Satelliet hospitality furniture has been established in 1971 in The Netherlands and has become an authority in the field of hospitality furniture. Hospitality is on the rise in more and more markets. Atmosphere goes above and beyond pure functionality, but comfort and quality will always be in style. With Satelliet

Originals we want to offer creatives in the hospitality interior sector the tools to deliver our promise on a larger scale. We believe that sharing our creativity and expertise in the form of a contemporary furniture collection will contribute to the creation of unique hospitality locations: places where people like to meet.

ITY

ADE

**Tailored design**

Satelliet Originals' collection is unique and responds to the ever-changing needs of users and guests. Each piece of furniture in the Originals collection has its own character, its own face, and in this way supports the identity of a concept or interior. We know that every project is unique and that this requires

a wide and broad range of possibilities. The real strength of Satelliet Originals therefore lies in customisation. Due to the extensive choices in material and design, the possibilities with Satelliet Originals are unprecedented. Models, materials and colours must fit like a tailored suit.

BRAND NEW



 Capsule



 Evora

**Meet our
brand new
Originals**

NEW

Through years of experience in the hospitality furniture industry we are fully aware that trends follow each other at lightning speed. For this reason we are always searching for the latest developments and trends to inspire us. All with the aim to offer a qualitative and up-to-date collection. By being at the basis of every product within the

Satelliet Originals collection, we are able to respond quickly to the continuously changing wishes and needs of the market. Together with the versatile team of designers and our knowledge of the market trends, technical developments and materials we created Brand New Originals. All available to you to realize on point hospitality interiors.



NEW Serpent



NEW Prim



NEW Evora



NEW Arcadia



NEW Eclipse



NEW Yup



▲ Frans Schrofer

▲ Stijn van Woerkom

Ardie van Bommel ▲

▲ Erik Remmers

Jan Dijkstra ▲

Designers.



Meet our designers

What makes our collection truly original? The designers behind the unique designs. Satelliet Originals is not just a label with a versatile collection, there is also a very versatile team of progressive designers behind it. All of them believe that together you can achieve more than alone. These

collaborations are unique and give an extra dimension to the brand and the products. The eye, the hand and the heart of the designer, that's where Satelliet Originals makes the difference. It is a feeling, an emotion. Meet the designers and their Originals here.





I like it when a design
responds purely
to your feelings.
That matters are
scrupulous yet
not dull.

Jesse Visser

Be an original.

Jesse Visser

His unbridled curiosity combined with technical know-how and pure craftsmanship make Jesse Visser a versatile and interesting designer. Jesse is unframeable, yet all his designs have one common denominator: minimalist with a touch of poetry. Innovative ways of materialisation characterise his creations. 'I reduce a product to its essence. For me, the tension is in the play of vistas and surfaces.'

DESIGNED FOR SATELLIET ORIGINALS

- Arcadia

ABOUT



Scan the QR code for
more information.

Be an original.



Arcadia comes closest possible to perfection.

ARCADIA - JESSE VISSER





ARCADIA DESIGNER JESSE VISSER NAILED IT WITH THE CONTEMPORARY ARCADIA. THE FRAME AND SHELL FIT PERFECTLY TOGETHER AND BLEND IN ANY INTERIOR THAT BREATHES MODERNITY AND QUALITY. THE CURVED CHAIR AND STOOL ARE AS SIMPLE AS THEY ARE INGENUOUSLY UNIQUE AND BRING TRANSPARENCY AND AIRINESS. ARCADIA COMES CLOSEST POSSIBLE TO PERFECTION.



NEW ARCADIA SC

NEW ARCADIA HS

ARCADIA

Catchy colours like moss grey, black and terra in combination with the durable material makes the Arcadia family suitable for outdoor use. Which doesn't mean interior use is out of the question. This airy design by Jesse Visser is available in a chair and bar stool, giving you the possibility to create a flowing furniture landscape without compromising in style.

MATERIALS

frame	aluminium
frame finishing	powder coated
seat / back	aluminium

EXTRA

stackable	yes
outdoor	yes

COLOURS

frame	black , terra, moss grey
-------	--------------------------

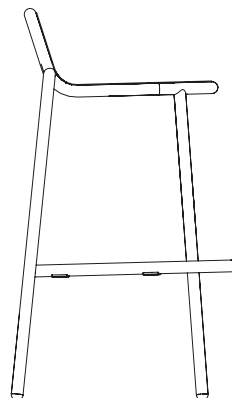
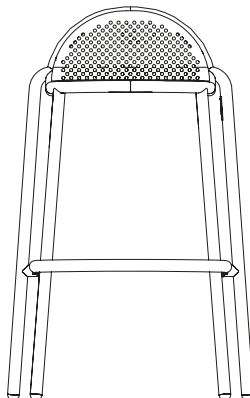
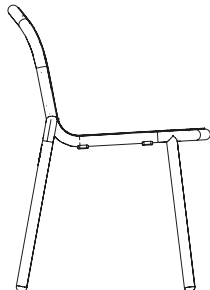
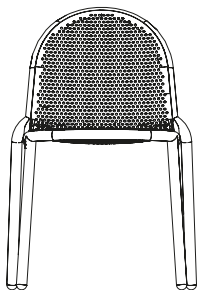

h h A h
80 56,5 54 46

h h A h
99,5 57 58 81





I am a wood enthusiast. Wood brings charm and suits my accessible design style, which is simple and without fuss.

Erik Remmers

Be an original.

Erik Remmers

Designer Erik Remmers rediscovered his love for product design. After studying furniture design, he joined a design agency 14 years ago and focused on interior design. Recently, he took up his sketchpad again and designed the wooden Pebble chair, lounge chair and bar stool for Satelliet Originals, as a counterpoint to what he sees as the one-sided supply of steel-framed furniture.

DESIGNED FOR SATELLIET ORIGINALS

- Pebble

ABOUT



Scan the QR code for more information.

Be an original.





A graceful and sturdy design.

PEBBLE - ERIK REMMERS





PEBBLE ORGANICALLY SHAPED, BEAUTIFULLY ROUND AND CUDDLY YET STURDY AND ROBUST. PEBBLE HAS A FRIENDLY APPEARANCE AND TAKES ITS NAME AFTER THE PEBBLESHAPED SEATING. THE DESIGN IS GRACEFUL, BUT THE WOODEN FRAME MAKES THE CHAIR TOUGH AND DISTINCTIVE.



PEBBLE SC



PEBBLE HS



PEBBLE LSC

PEBBLE

A design by Erik Remmers for Satelliet Originals, inspired by the round and flattened shape of pebbles on the bottom of a river. Pebble steals the show with this distinct 'future heritage look'. This model has slender, tapered legs and a beautiful curved, wooden detail against the softly upholstered back. The Pebble is available as chair, stool and lounge chair.

MATERIALS

frame	solid beechwood
frame finishing	lacquered
seat / back	upholstered, full

EXTRA

stackable	no
outdoor	no
CMHR foam	optional

COLOURS

frame	walnut, classic walnut, wenge, mahogany, cognac, classic honey, blank, matte blank, carbon, clay
seat / back	fabric or leather, Satelliet collection or supplier

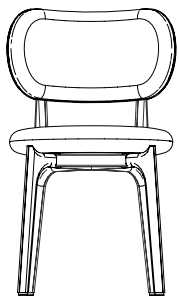

h h A h
80 51 45 48

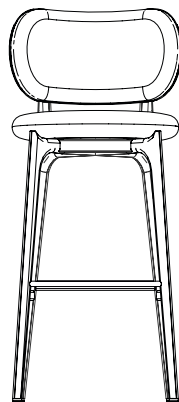
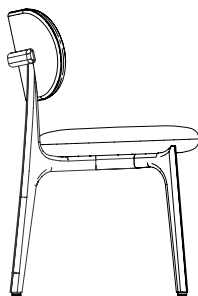

h h A h
107 56 46 80

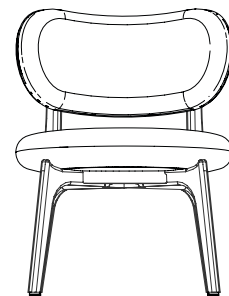
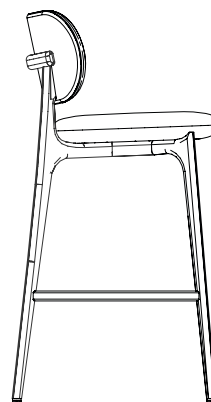

h h A h
71 60 55 43





I enjoy the puzzle of
aesthetics and poetry
on the one hand, and
construction and
production methods
on the other.

Elise Luttkik

Be an original.

Elise Luttkik

As a Master of Science in Integrated Product Design graduated in 2007 from TU Delft, Elise Luttkik's work is always characterized by well-thought-out technology and construction. She looks for ways to materialize illusions, using transparency, iridescent effects and rupture of light. Like the illusion of cushioning used in Chester chair.

DESIGNED FOR SATELLIET ORIGINALS

- Chester

ABOUT



Scan the QR code for
more information.

Be an original.





Playing with illusion.

CHESTER - ELISE LUTTIK





CHESTER CHESTER CHAIR TRANSLATES THE CLASSIC STYLE OF THE ICONIC CHESTERFIELD CHAIR TO CONTEMPORARY TIME. WITH MODERN TECHNIQUES, ASH WOOD IS ADAPTED TO MATCH THE NOBLESSE OF ORIGINAL LEATHER LUXURY.



CHESTER SC



NEW CHESTER HS



CHESTER

Chester Chair is designed for Satelliet Originals by Elise Luttik. She captured the softness and pattern of the iconic Chesterfield leather upholstery in wood. This 'new classic' is designed to fit dining tables in pronounced hospitality concepts. The seat features flat upholstery that enhances the uniqueness of the design. It creates additional creative possibilities and increases comfort.

MATERIALS

frame	ashwood
frame finishing	lacquered
seat	wood or upholstered
back	ashwood

EXTRA

stackable	no
outdoor	no

COLOURS

frame	walnut, classic walnut, wenge, mahogany, cognac, classic honey, blank, matte blank, carbon, clay
seat / back	wood or upholstered

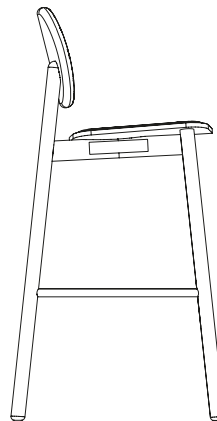
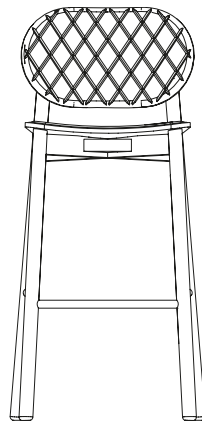
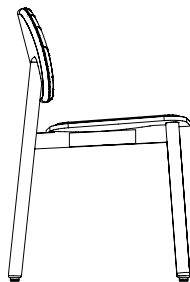
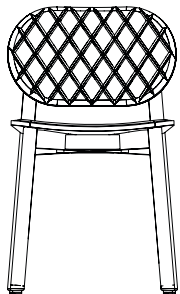

h h A h
79 41 46 46

h h A h
112,5 56 51 80





My design style can be described as friendly, cheerful, sympathetic and always a bit quirky.

Jan Dijkstra

Be an original.

Jan Dijkstra

In 2005 Jan Dijkstra graduated from the Design Academy in Eindhoven as an industrial designer and started his own studio: studio JanJannes. From there on Jan developed his own style that he describes as 'friendly, cheerful, sympathetic and always a bit quirky'. Jan brings his design to life by making optimal use of his creativity and imagination.

DESIGNED FOR SATELLIET ORIGINALS

- Cozito
- Fioli
- Olyn

ABOUT



Scan the QR code for more information.



COZITO STEEL FRAMES ARE BEING USED IN INCREASINGLY INGENUOUS WAYS IN FURNITURE DESIGN. IN THE CASE OF THE COZITO, A STRIKING STEEL DETAIL HAS BEEN ADDED TO THE BACK OF THIS CHAIR. IN COMBINATION WITH THE UPHOLSTERY OF THE SEAT AND THE EXTRA HIGH BACKREST, IT IS SIMPLY A STRIKING DESIGN WITH ITS OWN CHARACTER.



COZITO AC



COZITO HS



COZITO

Cozito was exclusively designed for Satelliet Originals by the Dutch product and furniture designer Jan Dijkstra. The Cozito has a wired, steel frame with an upholstered seat and back. It is simply an eye-catching chair with its own character. The Cozito is also available as an armchair and a stool.

MATERIALS

frame	metal, steel
frame finishing	powder coated
seat	upholstered
back	wire steel, upholstered

EXTRA

stackable	no
outdoor	no
CMHR foam	yes

COLOURS

frame	black standard, various RAL colours (request)
seat / back	fabric or leather, Satelliet collection or supplier

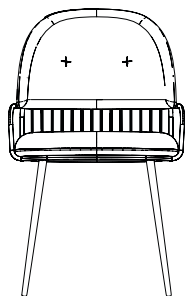

h h A h
81 51 51 45

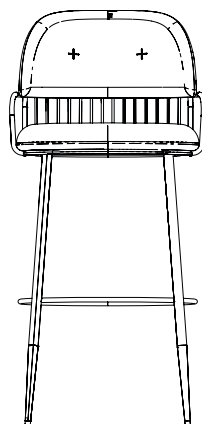
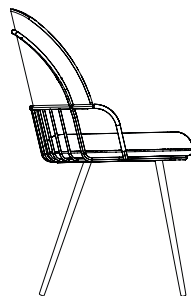

h h A h
112 51 51 80

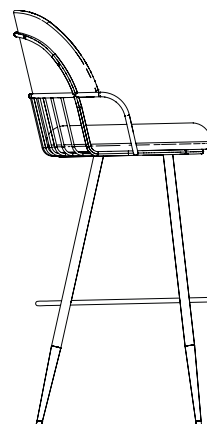



FIOLI AC

FIOLI LAC

FIOLI HS

FIOLI

Fioli is exclusively designed for Satelliet Originals by the Dutch designer Jan Dijkstra. The steel framework of the Fioli makes the chair a special one. Not only for its edgy look, but because the steel frame follows the contour of the seat. The seat and back are fully upholstered for maximum comfort.

MATERIALS

frame	metal, steel
frame finishing	powder coated
seat shell	upholstered, flat

EXTRA

stackable	no
outdoor	no
CMHR foam	yes

STANDARD COLOURS

FRAME RAL 1005 honey yellow, RAL 1036 pearl gold, RAL 3004 purple red, RAL 3012 beige red, RAL 5003 sapphire blue, RAL 5020 oceanblue, RAL 6011 reseda green, RAL 7016 anthracite grey, RAL 7021 black grey, RAL 7042 traffic grey a, RAL 9005 jet black, RAL 9010 pure white, NCS 2005-B80G misty grey, NCS 4050-Y60R russet orange, NCS 5020-R80B koi blue, NCS 7010-G10Y hunter green

SEAT / BACK fabric or leather, Satelliet collection or supplier

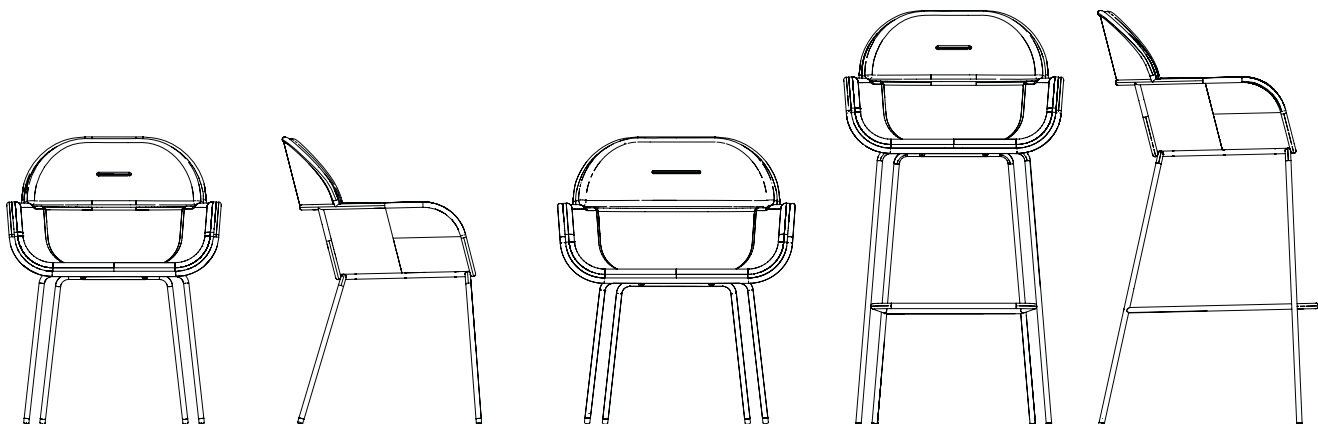

h h A h
79 63 62 46

h h A h
76 64 66 43

h h A h
115 63 62 80



FIOLI THE DESIGN OF THE FIOI IS INSPIRED BY ROSE PETALS. THE PETALS' ROUND, OPEN SHAPE LOOKS CHEERFUL, FRIENDLY AND INVITING. THE STEEL FRAME OF THE FIOI ELEGANTLY DEFINES THE CONTOURS OF THIS DESIGN. THE MOULDED SEAT SHELL CONTINUES UNDER THE ARMRESTS.



OLYN SC



OLYN HS-WB



OLYN HS

OLYN

The Olyn series, designed exclusively for Satelliet Originals by Jan Dijkstra, has a steel frame that standardly comes in the colour matte black. The seat and back are upholstered in a fabric or leather of choice. The family consists of a side chair, an armchair and a stool with or without backrest.

MATERIALS

frame	metal, steel
frame finishing	matt black powder coated
seat / back	upholstered, flat
armrests	upholstered

EXTRA

stackable	no
outdoor	no

COLOURS

frame	black standard, various RAL colours (request)
seat / back	fabric or leather, Satelliet collection or supplier

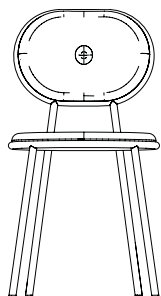

h h A h
81 51 44 46

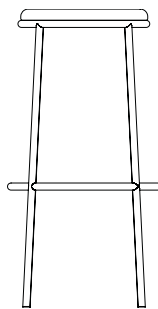

h h A h
80 41 41 80

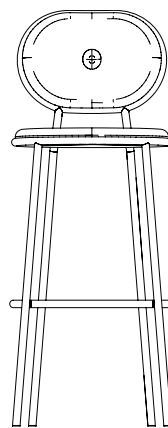

h h A h
111 50 43 80

OLYN OLYN HAS A VERY DISTINCTIVE LOOK. THE CHAIR IS UNIQUE BECAUSE THE METAL FRAME EMBRACES THE SEAT AND BACKREST OF THIS COMPACT AND CHARACTERFUL DESIGN.







**A chair is one of the
hardest things, but
also one of the most
beautiful things
to design.**

Lars Snellaars

Be an original.

Lars Snellaars

Lars Snellaars graduated from the Design Academy in Eindhoven in 2006 and has been working in his own design studio ever since. For him the most beautiful product to design is a chair. He calls it pure architecture. To Lars a chair is much more than a tool. A chair is defined by its vision, form and functionality, with the individual in his environment as its focal point.

DESIGNED FOR SATELLIET ORIGINALS

- ReUnited
- Circl

ABOUT



Scan the QR code for
more information.

Be an original.



Storytelling with a frivolous touch.

REUNITED - LARS SNELLAARS





REUNITED THE REUNITED, A ROARING TWENTIES CHAIR. A TYPICAL SNELLAARS DESIGN: WITH A CLEAR STORY AND FUNCTIONAL DESIGN. THE REUNITED CHAIR REFERS TO THAT LIVELY PERIOD A CENTURY AGO. THAT MEANS NO RIGID, ANGULAR SHAPES BUT RATHER SOFT AND ROUND. THE REUNITED REFLECTS THE SOCIETY WE LIVE IN TODAY.



REUNITED SC



REUNITED HS



REUNITED

The design stands out with its Art Deco style and a cross in the backrest. The expressive chair can be provided in gold and silver in combination with different colours. The upholstery is nice and soft. The fringes are like the nonsense of life: you don't need them, but they make everything more fun.

MATERIALS

frame	metal, steel
frame finishing	powder coated
seat / back	upholstered, full

EXTRA

stackable	no
outdoor	no
CMHR foam	yes

STANDARD COLOURS

FRAME RAL 1005 honey yellow, RAL 1036 pearl gold, RAL 3004 purple red, RAL 3012 beige red, RAL 5003 sapphire blue, RAL 5020 oceanblue, RAL 6011 reseda green, RAL 7016 anthracite grey, RAL 7021 black grey, RAL 7042 traffic grey a, RAL 9005 jet black, RAL 9010 pure white, NCS 2005-B80G misty grey, NCS 4050-Y60R russet orange, NCS 5020-R80B koi blue, NCS 7010-G10Y hunter green, PO57 Brass optic

SEAT / BACK fabric or leather, Satelliet collection or supplier

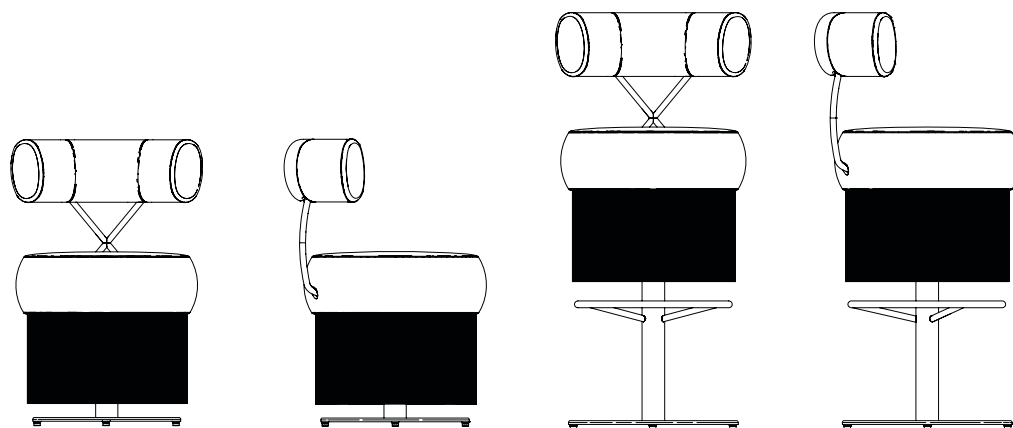

h h A h
82 60 59 46

h h A h
103 60 46 80



CIRCL AC



CIRCL HS



CIRCL 04 HS

CIRCL

The Circl collection was designed exclusively for Satelliet Originals by designer Lars Snellaars. The collection has a steel frame that can be finished in various RAL colours. The seat shell is fully upholstered with a fabric or leather of choice and comes standard with fire-retardant foam (CMHR).

MATERIALS

frame	metal, steel
frame finishing	powder coated
seat / back	shell, upholstered

EXTRA

stackable	no
outdoor	no
CMHR foam	yes

STANDARD COLOURS

FRAME RAL 1005 honey yellow, RAL 1036 pearl gold, RAL 3004 purple red, RAL 3012 beige red, RAL 5003 sapphire blue, RAL 5020 oceanblue, RAL 6011 reseda green, RAL 7016 anthracite grey, RAL 7021 black grey, RAL 7042 traffic grey a, RAL 9005 jet black, RAL 9010 pure white, NCS 2005-B80G misty grey, NCS 4050-Y60R russet orange, NCS 5020-R80B koi blue, NCS 7010-G10Y hunter green

SEAT / BACK fabric or leather, Satelliet collection or supplier

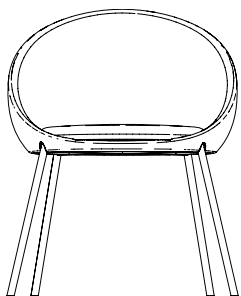

h h A h
79 59 63 47

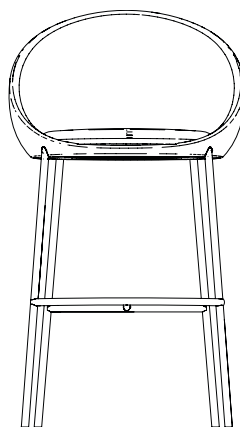
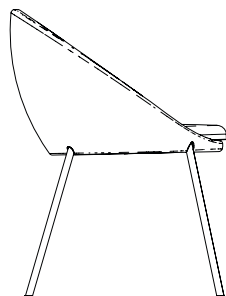

h h A h
113 68 80 63

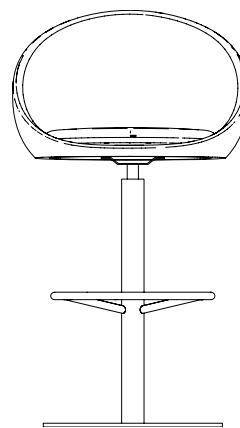

h h A h
113 68 80 63



CIRCL THE DISTINCTIVE ROUND AND CONVEX SHAPES DOES THE NAME CIRCL JUSTICE AND ELEGANTLY DEFINES THE CONTOURS OF THIS DESIGN. THE PREFORMED SHELL IS MADE OF INJECTION FOAM. THE COMBINATION OF SHAPES AND MATERIALS GIVES THIS MODEL A PERFECT SEAT.





A good design should feel like new and at the same time particularly accessible. As if it has always been there.

Jonathan & Babke

Be an original.

Hofmeijer
& Dekker

This designer duo started a studio together in 2011, after graduating from the Design Academy in Eindhoven. Their motto is: 'a design only comes to life when it is used', whether it is products or complete interiors. Jonathan delves into the details, while Babke takes care of the appearance.

DESIGNED FOR SATELLIET ORIGINALS

- 25.25

ABOUT



Scan the QR code for more information.

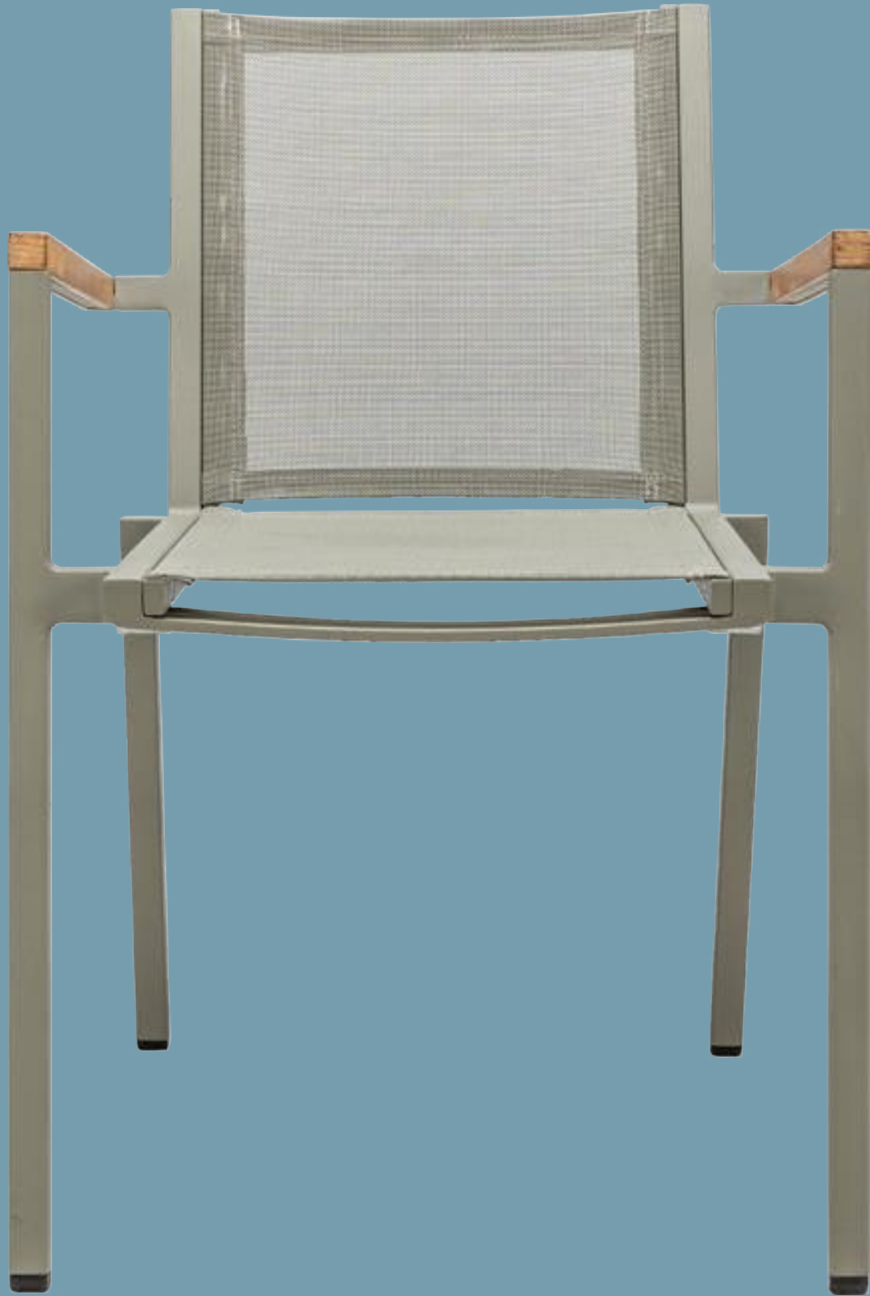

25.25 DESIGNER DUO JONATHAN HOFMEIJER AND BABKE DEKKER IS RESPONSIBLE FOR THE MINIMAL YET EFFICIENT DESIGN FOR THE 25.25. THE 25.25 IS A STRAIGHTFORWARD, ALL-AROUNDER AND LIGHTS UP ANY ROOM.



25.25 AC



25.25 LAC

25.25

The designer duo made a stackable patio chair that has grown into a complete furniture collection: the 25.25 series. Named after the dimensions of the materials used: tubular aluminium profiles of 25 x 25 mm. Armchair 25.25 is stackable and suitable for outdoor use.

MATERIALS

frame	metal, aluminium
frame finishing	powder coated
seat / back	batyline, upholstered, teak
armrests	teak

EXTRA

stackable	yes
outdoor	yes (except 25.25 LAC)

COLOURS

frame	black, moss grey, olive green, terra
seat / back	black, moss grey, olive green, terra

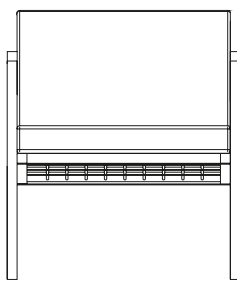
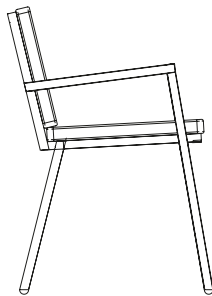
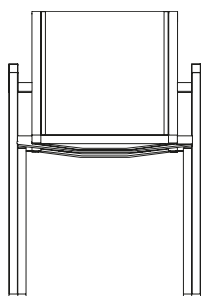

h h A h
80 60 58 45

h h A h
63 81 63 39



In our design process
the applicability for the
hospitality industry is
key. It's simply part
of our DNA.

Wessel, Chris & Gijs

Be an original.

studio
satelliet

Studio Satelliet's creative design team consists of Chris Montijn-Spiering, Wessel Storms and Gijs van Essen. Together, they have a rock-solid mix of experience, ambition and passion for interior and product design. Their common denominators: learning by doing, respecting each other, giving space to creativity and being involved from A to Z in the creation of a model or collection. They call this dynamic design poetry: the result of working together in a natural, almost symbiotic way.

DESIGNED FOR SATELLIET ORIGINALS

- | | |
|----------|-------------|
| - Prim | - Chantilly |
| - Evora | - Current |
| - Manado | - Gerlin |
| - Lux | - Code |
| - Canu | |

Check out more designs: satellietoriginals.net

ABOUT



Scan the QR code for
more information.

Be an original.



She is your key to success.

PRIM - STUDIO SATELLIET





PRIM YOUR CONCEPT FULLY BLOSSOMS WITH THE ELEGANTLY DESIGNED PRIM. THIS MONDAIN CHAIR GUARANTEES HOURS OF HOSPITALITY ENJOYMENT AND RELAXED TABLE CONVERSATIONS WITH FRIENDS. FROM EVERY ANGLE HER BEAUTIFUL, ROUND AND ORGANIC DESIGN EXUDES EXCITEMENT AND DYNAMISM. PRIM IS WILD AND FREE, LIKE THE PRIMROSE IN NATURE. SHE IS YOUR KEY TO SUCCESS.



NEW PRIM SC

NEW PRIM AC

PRIM

Prim was designed for Satelliet Originals by Studio Satelliet and is fully customisable. From the colour of the wooden frame to different upholstery in back, seat and back of the back. Taking a seat in the Prim is like sitting on a bed of flower petals. This model is as very inviting as it is extremely comfortable.

MATERIALS

Solid Beechwood	beech, metal, steel
Lacquered	lacquered, powder coated
upholstered	upholstered, full

EXTRA

stackable	no
outdoor	no
CMHR foam	optional

COLOURS

frame	walnut, classic walnut, wenge, mahogany, cognac, classic honey, blank, matte blank, carbon, clay
seat / back	fabric or leather, Satelliet collection or supplier

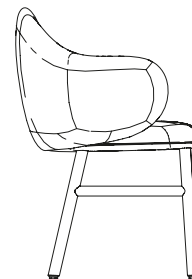
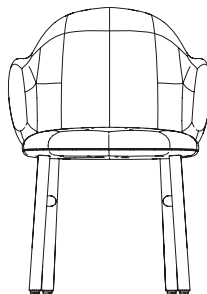
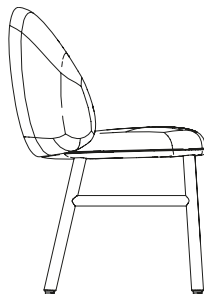
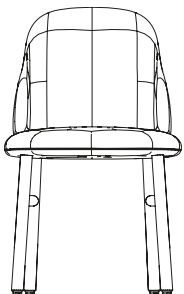

h h A h
81 59 54 46

h h A h
81 59 60 46



EVORA STUDIO SATELLIET PRESENTS THE EVORA FOR SATELLIET ORIGINALS. A FRIVOLOUS CHAIR THAT FITS PERFECTLY IN ANY STYLE INTERIOR. THE SLENDER, STEEL FRAME - TOGETHER WITH THE ROUNDED DESIGN -GIVES THIS MODEL A FRIENDLY CHARISMA. BECAUSE THE RATTAN AND CANE COMBINED BACK ALSO FORMS THE ARMRESTS, THIS STYLISH CHAIR COMPLETELY EMBRACES YOU.



NEW EVORA SC



NEW EVORA AC



NEW EVORA HS

EVORA

The endless upholstery options make the stylish Evora versatile in application for a variety of interiors. Upholster back and seat in the same pattern or play with the look by combining different materials, colours and designs. The Evora is available in two different versions: with arm or without. The woven, continuous armshell is a real looker.

MATERIALS

frame	metal, steel
frame finishing	powder coated
seat / back	upholstered
armrest	rattan + natural cane

EXTRA

stackable	no
outdoor	no
CMHR foam	standard

STANDARD COLOURS

FRAME RAL 1005 honey yellow, RAL 1036 pearl gold, RAL 3004 purple red, RAL 3012 beige red, RAL 5003 sapphire blue, RAL 5020 ocean blue, RAL 6011 reseda green, RAL 7016 anthracite grey, RAL 7021 black grey, RAL 7042 traffic grey a, RAL 9005 jet black, RAL 9010 pure white, NCS 2005-B80G misty grey, NCS 4050-Y60R russet orange, NCS 5020-R80B koi blue, NCS 7010-G10Y hunter green

SEAT / BACK fabric or leather, Satelliet collection or supplier

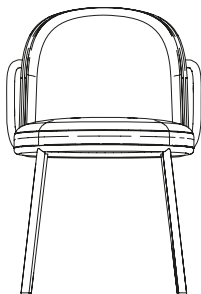

h h A h
80 62 54 47

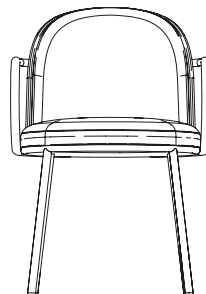
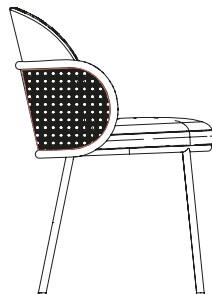

h h A h
80 62 56 47

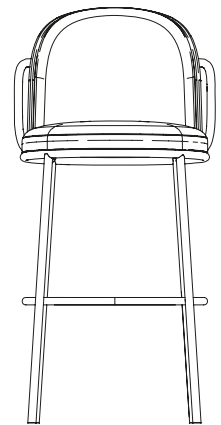
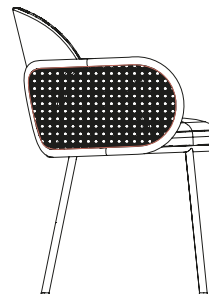

h h A h
113 62 54 80



MANADO SC



MANADO SC



MANADO HS

MANADO

The chair has an aluminium frame that comes in the colour black as standard. The seat and back of the Manado are both interwoven with natural cane and give this design the characteristic Thonet look. The seat can be finished in cane or fitted with a flat upholstery with a fabric or leather of your choice. The powder-coated aluminium frame gives it a contemporary touch.

MATERIALS

frame	metal, aluminium
frame finishing	powder coated
seat	natural cane / upholstered, flat
back	natural cane

EXTRA

stackable	no
outdoor	no

COLOURS

frame	black
seat / back	natural cane, fabric or leather, Satelliet collection or supplier

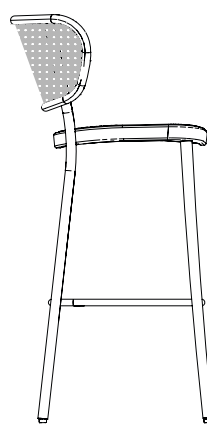
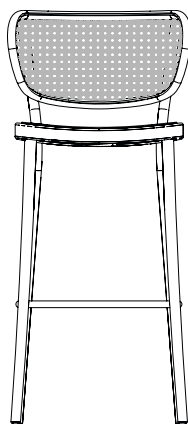
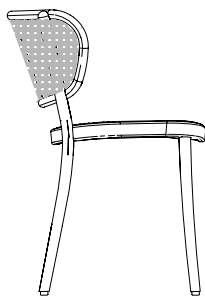
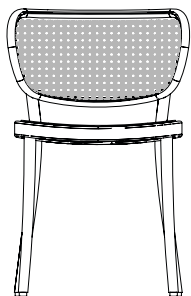

h h A h
78 54 49 46

h h A h
111 55 49 80

MANADO IS A DESIGN BY STUDIO SATELLIET. WHEN YOU FIRST LAY EYES ON HER, IT MAY GIVE YOU HINTS OF A MODERN THONET-CHAIR.





LUX THIS LUXURY COLLECTION REALLY INVITES YOU TO TAKE A SEAT AND ENJOY THE COMFORT. THE CHAIRS AND STOOL WERE DESIGNED BY STUDIO SATELLIET AND ARE DISTINGUISHED BY THE FUSION OF THE RECOGNISABLE ROUND AND CONVEX SHAPES.



LUX SC



LUX METAL AC



LUX LAC



LUX HS

LUX

The Lux has the shape of a bullet, the chair is predominantly round. You have options for a wooden or steel frame and an upholstered seat. The lux is optionally available with brass socks.

MATERIALS

frame	beech, metal, steel
frame finishing	lacquered, powder coated
seat / back	upholstered, full

EXTRA

stackable	no
outdoor	no
CMHR foam	optional
others	brass socks optional

COLOURS

frame	black
seat / back	fabric or leather, Satelliet collection or supplier

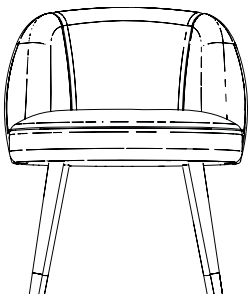

h h A h
75 66 62 50

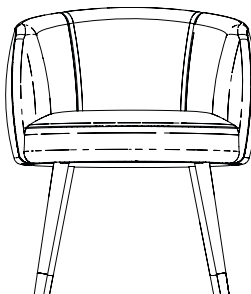
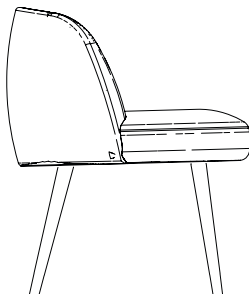

h h A h
76 65 66 50

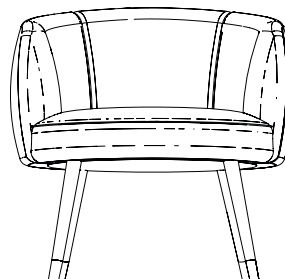

h h A h
71 70 73 47

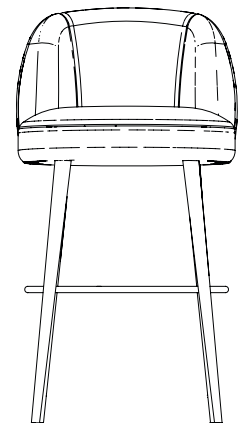

h h A h
104 64 62 80



CANU SC



CANU SOFT SC



CANU HS



CANU SOFT HS

CANU

The Canu is a design by Studio Satelliet. The chair has round shapes, pretty joints and is solid but slender. The seat is fitted with Danish cord, but can also be upholstered with a fabric or leather of your choice.

MATERIALS

frame	ashwood
frame finishing	lacquered
seat	danish cord, upholstered, leather
back	ashwood

EXTRA

stackable	no
outdoor	no

COLOURS

frame	walnut, classic walnut, wenge, mahogany, cognac, classic honey, blank, matte blank, carbon, clay
seat / back	danish cord (natural or black) or upholstered, leather

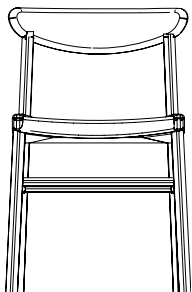

h	h	A	h
78	50	50	46

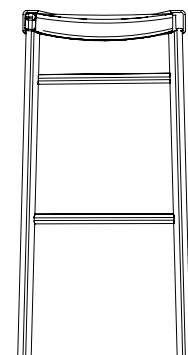
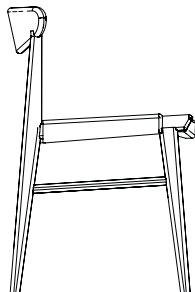

h	h	A	h
82	40	40	82



CANU A DESIGN CANNOT LOOK MORE SCANDINAVIAN THAN THE CANU. THIS FOCUS ON NATURE IS REFLECTED IN THE MATERIALS USED: WOOD AND WICKER. IN THE CANU CHAIR SERIES, NATURE INSPIRES CLEAR DESIGN, ORGANIC LINES AND PURE MATERIALS. THE ASHWOOD FRAME COMPLEMENTS THE DESIGN AND FORM THE LANGUAGE OF THE CHAIR.

Be an original.



A classic design with a soft touch.

CHANTILLY - STUDIO SATELLIET





CHANTILLY THAT A CHAIR MADE OF STEEL CAN ALSO LOOK SOFT AND ROMANTIC IS PROVEN BY THE NEW CHANTILLY. THE GRACEFUL, CLASSIC LINES GIVE THE DESIGN ITS CHARM. ROUND AND RETRO, BUT ALSO SOFT, CUDDLY AND PLAYFUL. WE LOVE THAT RETRO WINK!



CHANTILLY SC



CHANTILLY AC



CHANTILLY

Chantilly is a design by Studio Satelliet. Retro with a wink, and romantic without being overly decorative. Give way to an airy, feminine retro style full of round shapes, soft fabrics and floral designs. A touch prissy, yet cool. That is Chantilly, a chair made of curved steel, a classic design and a soft touch because of the cushion with fringes.

MATERIALS

frame	stainless, steel
frame finishing	powder coated
seat / back	separate seat and back cushion available

EXTRA

stackable	yes
outdoor	yes
CMHR foam	no

COLOURS

frame	white, RAL 1019 grey beige
seat / back	white, RAL 1019 grey beige

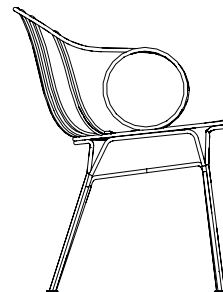
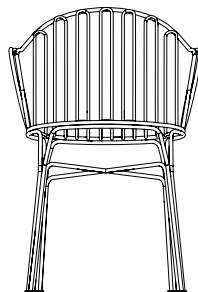
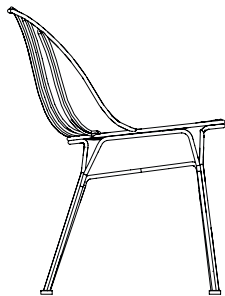
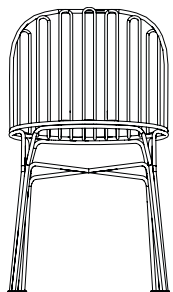

h h A h
76 58 43 46

h h A h
76 58 53 46



 CURRENT SC



 CURRENT AC



 CURRENT LAC

CURRENT

Current is part of the Satelliet Originals collection and is the first family of products made entirely of recycled materials. Current falls under the initiative SUM - Still Usable Materials. The frames of the various designs are made from recycled aluminium and recycled plastic wickerwork.

MATERIALS

frame	metal, recycled aluminum
frame finishing	powder coated
seat	upholstered, full, recycled foam
back	recycled HDPE wickerwork

EXTRA

stackable	no
outdoor	no
others	ring pattern or cane pattern Still Usable Materials collection

COLOURS

frame	black
seat	fabric or leather, Satelliet collection or supplier



still usable materials

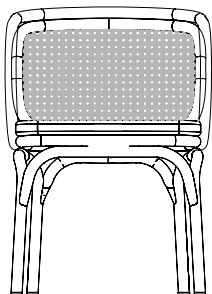

h h A h
78 58 53 48

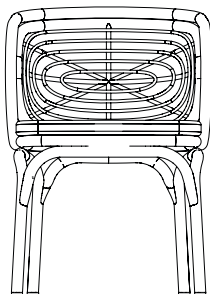

h h A h
78 58 57 48

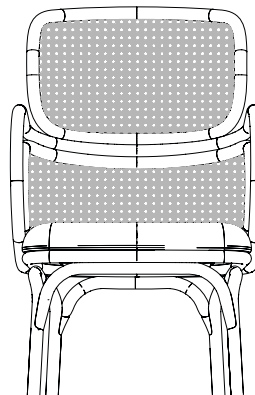
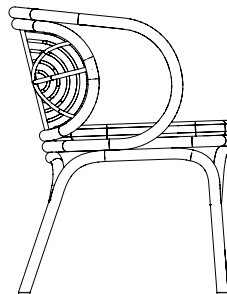

h h A h
92 78 61 43

CURRENT THE CURRENT OWES ITS NAME TO TWO REASONS: THE CURRENT OF THE SEA WHERE MOST MATERIALS COME FROM AND TODAY'S ZEITGEIST. IN A WORLD WHERE SUSTAINABILITY IS THE NEW MANTRA, CURRENT FEELS LIKE THE RIGHT NAME TO SHOW INVOLVEMENT TO THAT MATTER





GERLIN THE GERLIN IS EVERYMAN'S FRIEND. THE CHAIR IS
UTMOST VERSATILE DUE TO ITS SIMPLE DESIGN.
THEREFORE, THE GERLIN ADDS COMFORT AND
FLAIR TO ANY SPACE. CONICAL, COMPACT LEGS AND
SLIGHTLY CURVED SEAT AND BACK ELEMENTS FORM
THE BASIS FOR ITS DESIGN.



GERLIN SC



GERLIN MESH AC



GERLIN LAC



GERLIN MESH HS

GERLIN

Gerlin is a design by Studio Satelliet. The collection leaves a dazzling amount of room for a personal touch in terms of frame finishes and upholstery. You choose how you want your Gerlin: in plywood, steel wire or fully upholstered.

MATERIALS

frame	metal, steel
frame finishing	powder coated
seat / back	upholstered, full, metal, wire steel, wood, oak plywood
armrests	bakelite

EXTRA

stackable	no
outdoor	no
CMHR foam	optional

COLOURS

frame	matt black standard, brass, various RAL colours (on request)
seat / back	fabric or leather, Satelliet collection or supplier

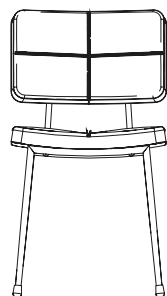

h h A h
80 50 43 47

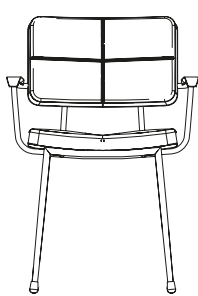
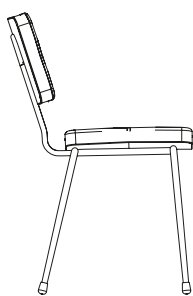

h h A h
80 50 57 47

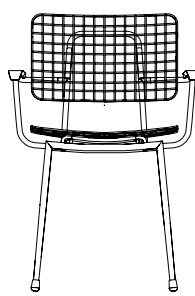

h h A h
81 51 57 47

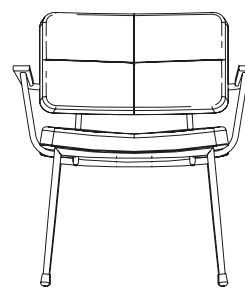

h h A h
74 65 68 41

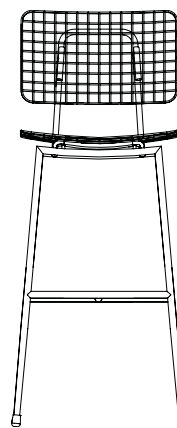

h h A h
112 53 47 80



 CODE SC



 CODE AC



 CODE HS

CODE

The idea for Code grew out of the previous sustainable models developed by Studio Satelliet. Those who dare to opt for a colourful, cheerful, cool interior will be right with Code. The chair is available in different colours: ocean blue, forest green, desert yellow and galaxy black. The Code series consists of an armchair, chair and barstool.



still usable materials

MATERIALS

frame	recycled aluminium
frame finishing	powder coated
seat / back	recycled plastic

EXTRA

stackable	yes
outdoor	no
others	Still Usabe Materials collection

COLOURS

frame	black, RAL 1024 ochre yellow, RAL 5003 Sapphire blue, NCS S 7010-B70G
seat / back	galaxy black, desert yellow, ocean blue, forest green

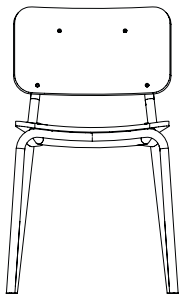

h h A h
81 53 48 46

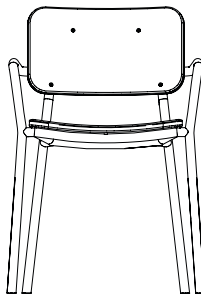
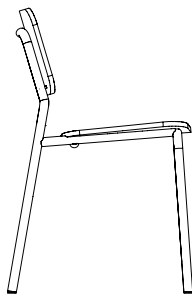

h h A h
81 53 55 46

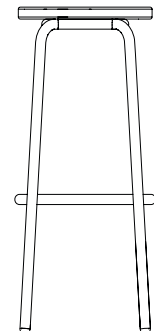
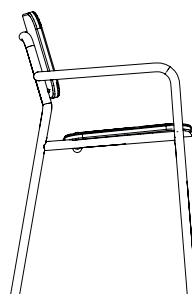

h h A h
80 45 45 80



CODE CODE REPRESENTS THE VALUE OF STILL USABLE MATERIALS. THE FRAME IS MADE OF RECYCLED ALUMINIUM. THE SEAT AND BACK ARE MADE OF RECYCLED PLASTIC AND CONSISTS OF 100% 'POSTCONSUMER WASTE'. THE PLASTICS ARE SORTED BY COLOUR AND THEN REMELTED, CREATING THE CHARACTERISTIC BASE COLOUR WITH CHEERFUL SPECKLES.



ECLIPSE SPOT ON TREND ARE SOFAS AND CHAIRS INSPIRED BY ROUNDED PEBBLES AND FINISHED IN WARM, SOFT WOOLLEN FABRICS. STUDIO SATELLIET'S NEW ECLIPSE RANGE CONSISTS OF BEAUTIFUL, ROUNDED SHAPES ON A RAREFIED METAL BASE AND IS FRESH, CONTEMPORARY, AND EXTREMELY COMFORTABLE. SHE SEEMS TO SMILE AT YOU, INVITING YOU TO HAVE SEAT AND RELAX. ECLIPSE IS A REAL EYE-CATCHER IN YOUR INTERIOR.



NEW ECLIPSE LAC



NEW ECLIPSE LB 177-220

ECLIPSE

Eclipse – designed by Studio Satelliet - is available as a lounge seat and sofa in length 177 cm or 220 cm. Eclipse is fully upholstered in a strong woollen material in the colour's olive green and pebble white. Its modern, comfortable look make Eclipse ideal as an eye-catcher in the lobby, your entrance or meeting room.

MATERIALS

frame	metal, steel
frame finishing	powder coated
seat / back	upholstered

EXTRA

stackable	no
outdoor	no
CMHR foam	standard

COLOURS

frame	black
seat / back	Fabric or leather Satelliet collection or supplier

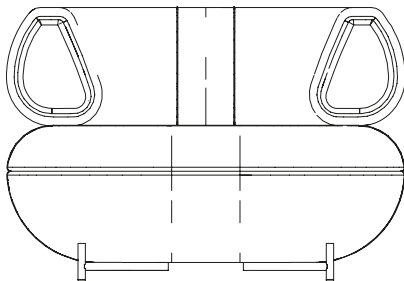

h h A h
74 87 108 42

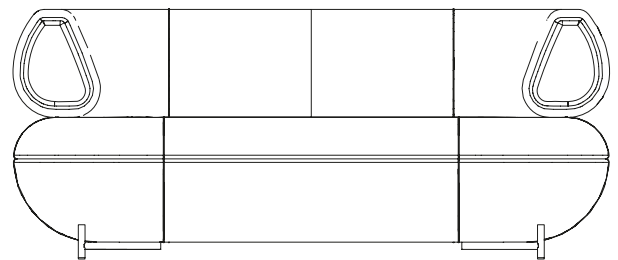
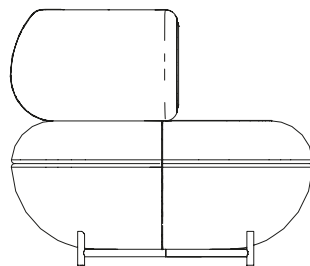

h h A h
74 87 177 | 220 42





**My work balances
between art and design.
I have a passion for
the art of making
something out
of nothing.**

Diederik Schneemann

Be an original.

Diederik
Schneemann

After completing the AKI Academy for Art & Design in Enschede, Diederik started his own company in Rotterdam: Studio Schneemann. As a designer – in the broadest sense of the word -he creates works that balance between art and design. He engages in a variety of disciplines: conceptual art and design, photography and art installations. His oeuvre distinguishes itself by re-using items, altering their looks and use in such a way a new concept and second life is created. In evoking a new, unexpected reality, he allows himself to be surprised and inspired by the simple things in everyday life.

DESIGNED FOR SATELLIET ORIGINALS

- Tube

ABOUT



Scan the QR code for
more information.



TUBE SC



TUBE AC



TUBE HS

TUBE

Tube is exclusively designed for Satelliet Originals by Diederik Schneemann. Tube has a slender steel frame. The seating and back are either made of plywood or can be fully upholstered. The Tube series consists of a chair, an armchair and a stool.

MATERIALS

frame	metal, steel
frame finishing	powder coated
seat / back	upholstered, flat
armrests	upholstered

EXTRA

stackable	no
outdoor	no
CMHR foam	yes

STANDARD COLOURS

FRAME RAL 1005 honey yellow, RAL 1036 pearl gold, RAL 3004 purple red, RAL 3012 beige red, RAL 5003 sapphire blue, RAL 5020 oceanblue, RAL 6011 reseda green, RAL 7016 anthracite grey, RAL 7021 black grey, RAL 7042 traffic grey a, RAL 9005 jet black, RAL 9010 pure white, NCS 2005-B80G misty grey, NCS 4050-Y60R russet orange, NCS 5020-R80B koi blue, NCS 7010-G10Y hunter green

SEAT / BACK fabric or leather, Satelliet collection or supplier

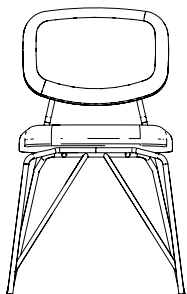

h h A h
80 53 50 47

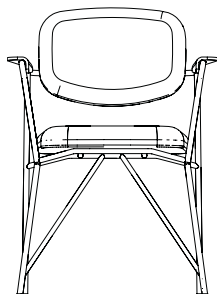

h h A h
80 53 53 47

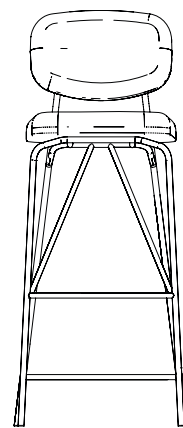
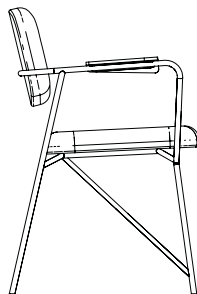

h h A h
106 49 44 80

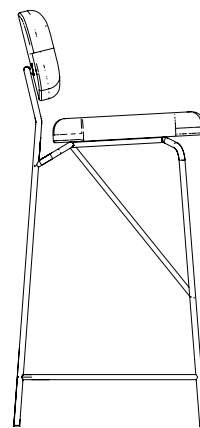

TUBE THE INTERPLAY OF LINES FORMED BY THE TUBULAR FRAME MAKES THE CHAIR A STAND-OUT. THE DESIGN EXPLORES THE TENSION BETWEEN STRAIGHT LINES AND ROUNDED FORMS. THE CONNECTION BETWEEN THE BACKREST AND THE FRAME IS A PARTICULARLY AESTHETIC DETAIL.







Design is meant to
be consumed, so it
has to be tasty.

Stijn & Victor

Be an original.

BURO NOW

Stijn van Woerkom, graduated designer at Design Academy Eindhoven, designed interiors for shops, restaurants and houses. Since the summer of 2019, they have joined forces in BURO NOW. Stijn and Victor are not guided by conventionalism and make their own plans. 'Design is meant to be consumed, so it has to be tasty.'

DESIGNED FOR SATELLIET ORIGINALS

- Biscuit

ABOUT



Scan the QR code for
more information.



BISCUIT SC



BISCUIT LSC



BISCUIT MS



BISCUIT HS

BISCUIT

The Biscuit series is exclusively designed for Satelliet Originals by the Dutch designers of BURO NOW. Biscuit has a steel frame that can be executed in various RAL colours. The back and seat are upholstered in a fabric or leather of your choice from our house-collection and standardly come with fire retardant foam (CMHR).

MATERIALS

frame	metal, steel
frame finishing	powder coated
seat / back	upholstered, full

EXTRA

stackable	no
outdoor	no
CMHR foam	yes

STANDARD COLOURS

FRAME RAL 1005 honey yellow, RAL 1036 pearl gold, RAL 3004 purple red, RAL 3012 beige red, RAL 5003 sapphire blue, RAL 5020 oceanblue, RAL 6011 reseda green, RAL 7016 anthracite grey, RAL 7021 black grey, RAL 7042 traffic grey a, RAL 9005 jet black, RAL 9010 pure white, NCS 2005-B80G misty grey, NCS 4050-Y60R russet orange, NCS 5020-R80B koi blue, NCS 7010-G10Y hunter green

SEAT / BACK fabric or leather, Satelliet collection or supplier

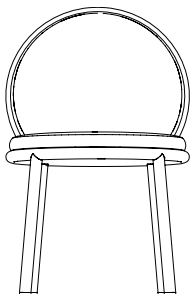

h h A h
80 57 52 46

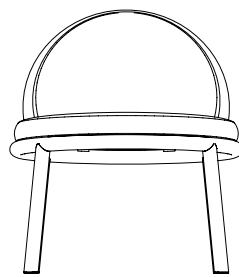
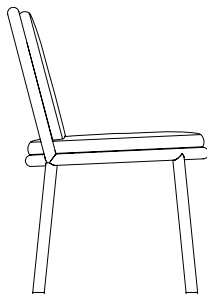

h h A h
70 65 59 43

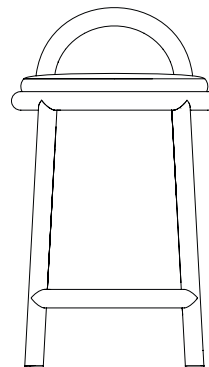

h h A h
73 45 43 60

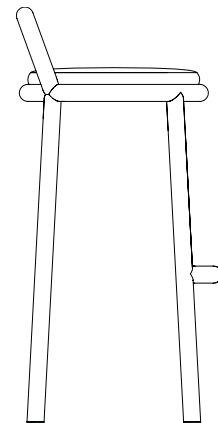

h h A h
93 46 39 80



BISCUIT CRAVING SOME SWEET DELIGHT? THE BISCUIT SATISFIES THAT NEED WITH ITS SEAT AND BACK THAT LOOK LIKE A COOKIE. THE CHAIR HAS A STURDY LOOK DUE TO THE THICK STEEL FRAME. IT IS A FUN, ROBUST CHAIR WITH A JOYOUS LOOK AND FEEL.





Our goal is to turn every design into a sensual experience. Smart functional products, where the character reinforces the brand identity.

Jon+Sven

Be an original.

Jon+Sven

Jon+Sven is a Dutch designer duo formed by Jon Assink and Sven Schimmer. Their goal is to turn every design into a sensual experience. Smart functional products, where the character reinforces the brand identity. In recent years Jon and Sven have built a broad portfolio, in which well-known Dutch and international brands are represented. Their style: friendly yet business-like, and soft with a surprisingly sharp edge.

DESIGNED FOR SATELLIET ORIGINALS

- Oso

ABOUT



Scan the QR code for more information.



OSO AN EYECATCHER IN EVERY SPACE. OSO HAS A DARING APPEARANCE AND STANDS FIRMLY ON ITS THICK WOODEN FEET. THE OSO IS PART OF A SERIES OF SOFAS THAT IS AVAILABLE IN, BOTH DINING AND LOUNGE HEIGHT



OSO AC



OSO B

OSO

The Oso series is exclusively designed for Satelliet Originals by the Dutch designers Jon+Sven. The playful shapes make this design a favourite in many interiors. The wooden frame with foam construction provides a robust base with soft seating.

MATERIALS

frame	wood, oak
frame finishing	lacquered
seat / back	upholstered, full

EXTRA

stackable	no
outdoor	no

COLOURS

frame	walnut, classic walnut, wenge, mahogany, cognac, classic honey, blank, matte blank, carbon, clay
seat / back	fabric or leather, Satelliet collection or supplier

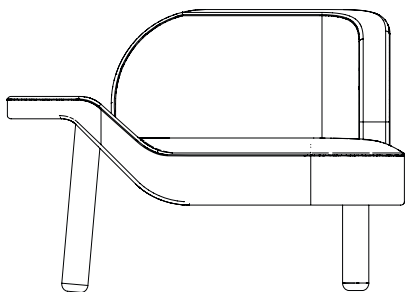

h h A h
75 80 100 40

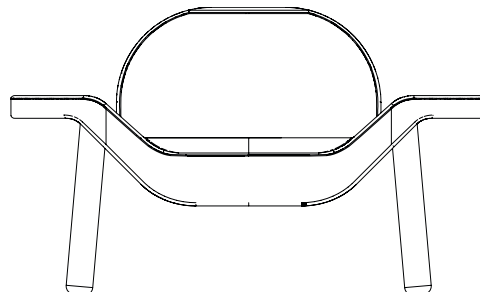

h h A h
75 80 120 40

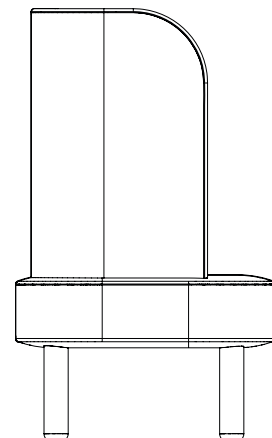

h h A h
160 80 -- 40



””

I'm inspired by
different shapes
and forms around
me and that
influences my
designs.

Frans Schrofer

Be an original.

Frans
Schrofer

Born into a family of artists and designers, Frans Schrofer graduated from the Design Academy in Eindhoven in 1983 and started his own studio in The Hague a few years later. Studio Schrofer is known for its recognisable world of shapes and has won various international design awards for innovation, technology and sustainability. Schrofer's 'hands-on design' guarantees ergonomically comfortable designs that are also visually appealing.

DESIGNED FOR SATELLIET ORIGINALS

- Serpent
- Loop
- Mistral
- Orbit
- Gelato

ABOUT



Scan the QR code for
more information.

Be an original.





What's not to love.

SERPENT - FRANS SCHROFER





SERPENT THE STRIKING, ORGANIC INTERPLAY OF LINES GIVES MODEL SERPENT A MYSTERIOUS CHARACTER AND A TOUCH OF FRENCH ALLURE. THIS ELEGANT CHAIR WITH HER SMOOTH, CURVED SHAPES RESEMBLES A COBRA WHO DANCES TO THE SOUND OF A FLUTE. SERPENT IS DANGEROUSLY BEAUTIFUL AND ATTRACTIVE. WHAT'S NOT TO LOVE.



NEW SERPENT AC



NEW SERPENT AC

SERPENT

Serpent is exclusively designed by Frans Schrofer for Satelliet Originals. The ultra black, semi-gloss frame in combination with the natural cane in the back and seating make Serpent stylish. Would you rather add a playful touch? Upholster the seat in any fabric you desire. Extra special: the combined use of recycled aluminium, rattan and cane makes Serpent a sustainable choice.

MATERIALS

frame	Recycled aluminium
frame finishing	powder coated
seat	Natural cane or upholstered
back	Natural cane

EXTRA

stackable	no
outdoor	no
CMHR foam/others	Still Usabe Materials collection

COLOURS

frame	black
seat / back	natural cane, fabric or leather Satelliet collection or supplier



still usable materials

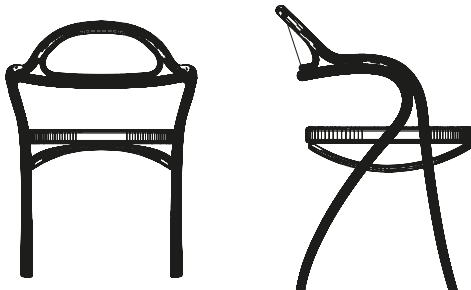

h h A h

82 52 52 47 - 49



LOOP HS

LOOP

The Loop, designed by Frans Schrofer, has a steel frame with an upholstered seat and back. The stool is rotatable, making it widely applicable in various hospitality settings. The characteristic steel frame can be customised and coated in various RAL colours. This freedom also applies to the extensive choice of back and seat upholstery.

MATERIALS

frame	metal, steel
frame finishing	powder coated
seat / back	upholstered, full

EXTRA

stackable	no
outdoor	no
CMHR foam	yes

STANDARD COLOURS

FRAME RAL 1005 honey yellow, RAL 1036 pearl gold, RAL 3004 purple red, RAL 3012 beige red, RAL 5003 sapphire blue, RAL 5020 ocean blue, RAL 6011 reseda green, RAL 7016 anthracite grey, RAL 7021 black grey, RAL 7042 traffic grey a, RAL 9005 jet black, RAL 9010 pure white, NCS 2005-B80G misty grey, NCS 4050-Y60R russet orange, NCS 5020-R80B koi blue, NCS 7010-G10Y hunter green

SEAT / BACK fabric or leather, Satelliet collection or supplier

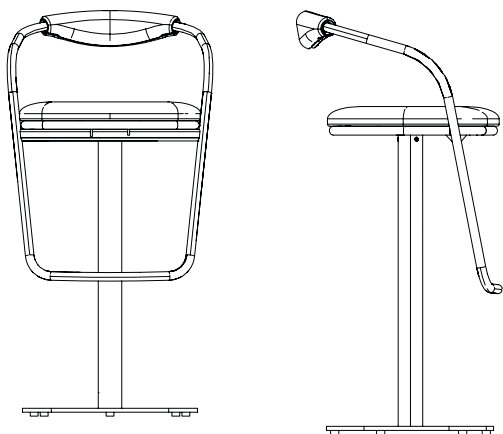

h h A h
104 50 52 80



LOOP HOW DO YOU MAKE A STEEL FRAME SPECIAL? DESIGNER FRANS SCHROFER HAS THE ANSWER. THE LINES OF THE FRAME CONTINUE FROM THE BACK INTO A FOOTREST, GIVING THE STOOL A FUTURISTIC AND PLAYFUL LOOK. THE FOOTPLATE FOLLOWS THE SHAPE OF THE SEAT. THE SWIVEL STOOL HAS A SMALL UPHOLSTERED BACK AND SEAT.



ORBIT THIS REMARKABLE DESIGN BY FRANS SCHROFER TAKES YOU INTO ORBIT. THE ROUND SHAPE OF THE SEAT AND BACK ARE EMPHASISED BY THE STRIKING FRAME THAT SEEMS TO FLOAT AROUND THE CHAIR.



ORBIT SC



ORBIT AC



NEW ORBIT HS

ORBIT

Orbit has been designed exclusively for Satelliet Originals by Frans Schrofer. The frame is striking and, together with the round shape of the seat and back, creates the unique character of this functional chair. The frame can be finished in different colours.

MATERIALS

frame	metal, steel
frame finishing	powder coated
seat / back	shell and back upholstered
armrests	upholstered

EXTRA

stackable	no
outdoor	no
CMHR foam	optional

STANDARD COLOURS

FRAME RAL 1005 honey yellow, RAL 1036 pearl gold, RAL 3004 purple red, RAL 3012 beige red, RAL 5003 sapphire blue, RAL 5020 ocean blue, RAL 6011 reseda green, RAL 7016 anthracite grey, RAL 7021 black grey, RAL 7042 traffic grey a, RAL 9005 jet black, RAL 9010 pure white, NCS 2005-B80G misty grey, NCS 4050-Y60R russet orange, NCS 5020-R80B koi blue, NCS 7010-G10Y hunter green

SEAT / BACK fabric or leather, Satelliet collection or supplier

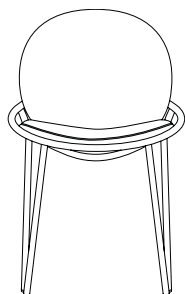

h h A h
84 62 53 48

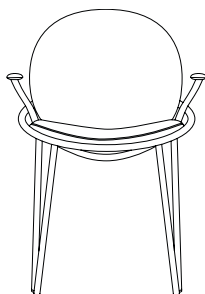

h h A h
84 62 61 48

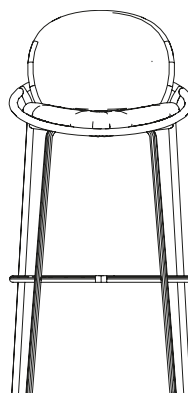

h h A h
106 58 52 80

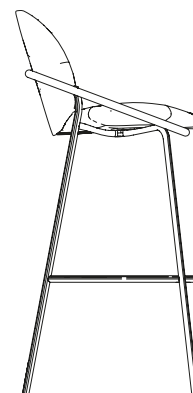



GELATO SC



NEW GELATO WOOD AC



GELATO LAC



GELATO HS

GELATO

The Gelato series is exclusively designed for Satelliet Originals by designer Frans Schrofer. The collection has a steel frame that comes standard in the colour black. On request, the frame can also be coated in other RAL colours. The seat shell is fully upholstered with a fabric or leather of your choice and standardly comes with fire-retardant foam (CMHR).

MATERIALS

frame	metal, steel
frame finishing	powder coated
seat / back	shell, upholstered, flat

EXTRA

stackable	no
outdoor	no
CMHR foam	yes

COLOURS

frame	black standard, various RAL colours (on request)
frame wood	walnut, classic walnut, wenge, mahogany, cognac, classic honey, blank, matte blank, carbon, clay
seat / back	fabric or leather, Satelliet collection or supplier

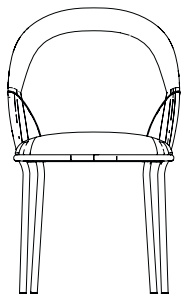

h h A h
80 53 53 47

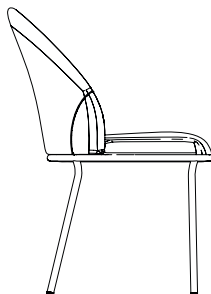

h h A h
116 53 52 80

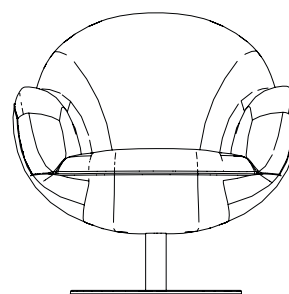
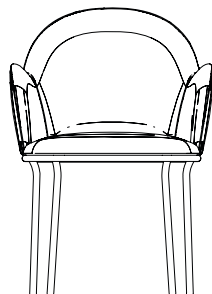

h h A h
86 73 84 43

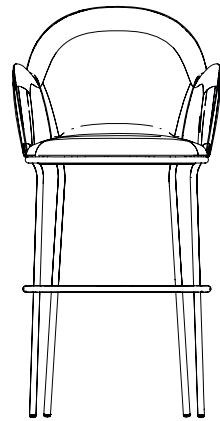

h h A h
116 53 52 80

GELATO GUESS WHAT'S THE ITALIAN WORD FOR ICE CREAM? GELATO! THE SHAPE OF THIS CHAIR IS LIKE STACKED SCOOPS OF ICE CREAM AND GIVES GELATO IT'S INVITING LOOK. THIS SHAPE SIMOULTANIOUSLY, CREATES THE ARMRESTS IN THE DESIGN.





MISTRAL A TRENDY CHAIR WHICH CAN BE CATEGORIZED AS 'NEW INDUSTRIAL'. THE CHAIR IS AVAILABLE IN TWO VARIANTS. THE MISTRAL EXUDES COMFORT AND HAS A CASUAL LOOK AND FEEL.



MISTRAL AC

MISTRAL

The Mistral series is exclusively designed for Satelliet Originals by designer Frans Schrofer. The practical steel frame carries a tub of wire steel with an upholstered cover. The characteristic design of the cover makes the Mistral look casual and sleek.

MATERIALS

frame	metal, steel
frame finishing	powder coated
seat / back	shell, wire steel, standard cushion
armrests	metal, wire steel, standard cushion

EXTRA

stackable	no
outdoor	no
CMHR foam	optional
others	seat and back cushion included

COLOURS

frame	black
seat	fabric or leather, Satelliet collection or supplier

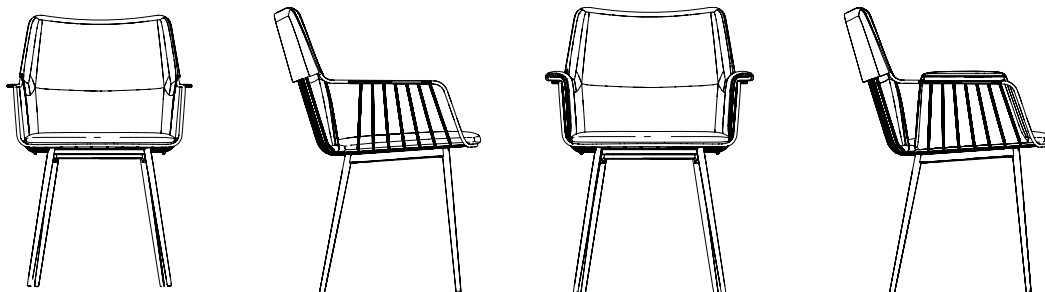

h h A h
84 60 58 48

h h A h
84 60 58 47





The design itself
is the core,
its implementation
or realisation
is an option,
not a 'must'.

Dave Keune

Be an original.

Dave Keune

Dave Keune enjoys working on various projects in his own studio. It is characteristic of his work that the design itself is the core. The execution or realization of his products are in his opinion an option, not a 'must'. The design of Dave Keune targets both aesthetic as functional values. While developing his design, either products or environments, Keune operates through layers of research, development and production.

DESIGNED FOR SATELLIET ORIGINALS

- Brewer
- Forge

ABOUT



Scan the QR code for
more information.



FORGE T

FORGE

Forge is a table made of solid oak wood that can be finished in the colours walnut, classic walnut, carbon, clay, wengé, cherry, mahogany, cognac, classic honey, white and matte white. The table is also available in natural or bleached ash wood.

Forge is available in six dimensions (table top): 200 x 80 cm, 200 x 100 cm, 225 x 100 cm, 250 x 100 cm, 275 x 100 cm and 300 x 100 cm. The footrest has a black coating.

MATERIALS

frame	wood, solid oak, ash wood
frame finishing	lacquered
table top	wood, solid oak, ash wood

EXTRA

stackable	no
outdoor	no
others	metal, steel footrest

COLOURS

frame / table top	walnut, classic walnut, wenge, mahogany, cognac, classic honey, blank, matte blank, carbon, clay
-------------------	--

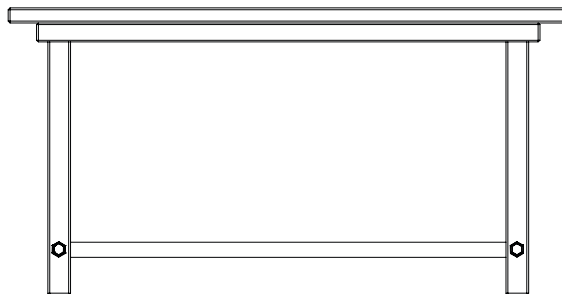
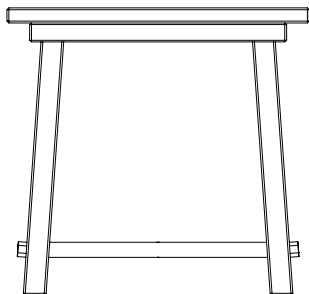

80 - 100 76 200 - 300



BREWER T

BREWER

Brewer is a table made of solid oak wood that can be finished in the colours walnut, classic walnut, carbon, clay, wengé, cherry, mahogany, cognac, classic honey, white and matte white.

The table is also available in natural or bleached ash wood.

Brewer is available in five dimensions (table top): 200 x 100 cm, 225 x 100 cm, 250 x 100 cm, 275 x 100 cm and 300 x 100 cm.

The footrest has a black coating.

MATERIALS

frame	wood, solid oak, ash wood
frame finishing	lacquered
table top	wood, solid oak, ash wood

EXTRA

stackable	no
outdoor	no
others	metal, steel footrest

COLOURS

frame / table top	walnut, classic walnut, wenge, mahogany, cognac, classic honey, blank, matte blank, carbon, clay
-------------------	--

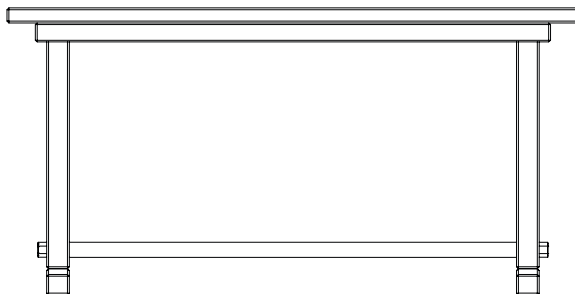
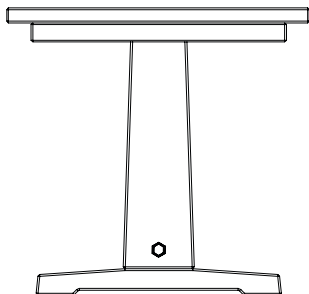

100



76



200 - 300



”

**The art of design
is to keep thinking
very purely. Trying to
maintain the simple,
pure form.**

Gerard van den Berg

Be an original.

Gerard
van den Berg

Although Gerard van den Berg grew up in the furniture company as the son of a furniture manufacturer, he first developed his artistic talents when he was trained as a painter. Later he studied furniture manufacturing at the MTS in Rotterdam and started working as a designer in his father's company. According to Van den Berg, the art of design is to keep thinking very purely. He tries to maintain the simple, pure form from the first sketch to the final production.

DESIGNED FOR SATELLIET ORIGINALS

- Montana

ABOUT



Scan the QR code for
more information.



MONTANA ACCORDING TO VAN DEN BERG, THE ART OF DESIGN IS TO KEEP THINKING VERY PURELY. HE TRIES TO MAINTAIN THE SIMPLE, PURE FORM FROM THE FIRST SKETCH TO THE FINAL PRODUCTION. MONTANA IS PURE, NONCHALANT AND LOOSE.



MONTANA COVER AC



MONTANA CUSHION AC

MONTANA

Van den Berg's signature, the metal framework with a baggy loose cover, make for an extremely comfortable casual looking chair. The Montana is stackable and suitable for outdoor use. The cushions are available in different fabrics.

MATERIALS

frame	metal, steel
frame finishing	powder coated
seat / back	textilene, full cover, cushion
armrests	textilene, full cover

EXTRA

stackable	yes
outdoor	yes
others	seat cushion included

COLOURS

frame	black
seat	fabric, Satelliet collection or supplier

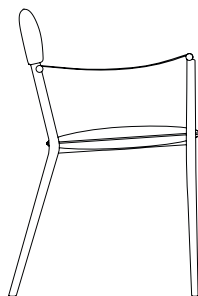
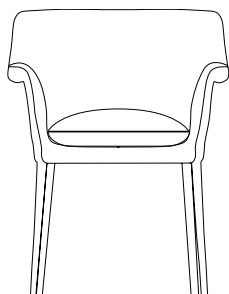

h h A h
80 51 58 46

h h A h
80 51 58 46



”
Every product is the result of a creative thinking process with one common dominator: bringing people together.

Ardie van Bommel

Be an original.

Ardie van Bommel

Ardie van Bommel graduated from the Design Academy Eindhoven in 2010. From her design studio BOMM she designs and develops new products and concepts defining private and public spaces. Each final product is the result of an enthusiastic, creative thought process with one common denominator: bringing people together. As a designer, Ardie is very involved: from the design phase to realization. She also likes to work together with other inspiring professionals, because she believes that in this way no challenge is too big.

DESIGNED FOR SATELLIET ORIGINALS

- Ear

ABOUT



Scan the QR code for more information.



EAR INTENDED AS A MODEL WHERE YOU CAN SIT TO SHUT YOURSELF OFF FOR A WHILE. THE EAR INVITES YOU FOR SOME ME-TIME, TO READ OR WORK. THIS GIGANTIC EYECATCHER LOVINGLY EMBRACES YOU, GIVING YOU SPACE AND PROTECTION. THIS CHAIR WAS EXCLUSIVELY DESIGNED FOR SATELLIET ORIGINALS BY THE DUTCH DESIGNER ARDIE VAN BOMMEL.



EAR AC

EAR

Ear has an oak frame and table top that can be finished in the colours walnut, classic walnut, wengé, cherry, mahogany, cognac, classic honey, blank and matte blank. The chair is fully upholstered with a fabric of your choice. The chair comes with an adjustable table top (25 mm thick) made of solid oak and a loose back cushion (45 x 45 cm).

MATERIALS

frame	wood, oak
frame finishing	lacquered
seat / back	shell, upholstered, flat

EXTRA

stackable	no
outdoor	no
others	loose back cushion

COLOURS

frame	walnut, classic walnut, wenge, mahogany, cognac, classic honey, blank, matte blank, carbon, clay
seat / back	fabric or leather, Satelliet collection or supplier

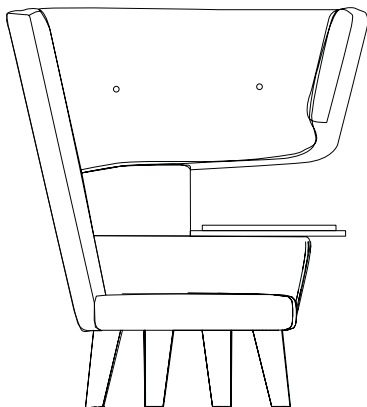

h h A h
162 150 123 47



””

I want to experience every facet of the design first. That's why I always build the prototypes myself.

Tom Frencken

Be an original.

Tom Frencken

Tom Frencken studied Interior Architecture and Furniture Design at the KHM in Mechelen. Since 2007 he has been working from his own studio on free work and assignments. Frencken makes timeless, high quality furniture that should last for several generations. His designs are known to have an idiosyncratic appearance.

DESIGNED FOR SATELLIET ORIGINALS

- Legs

ABOUT



Scan the QR code for more information.



LEGS DESIGNS BY TOM FRENCKEN OFTEN HAVE A CARTOONISH LOOKING TWIST. IN THIS DESIGN, THE CLEAR SHAPES AND ROUNDED LINES GIVE THE TABLE A DISTINCTIVE CHARACTER.



LEGS T

LEGS

This table is exclusively designed by Tom Frencken for the Satelliet Originals collection. The Table is available in a solid beech, a standard oak and an aged oak version. The table can be stained in various colours.

MATERIALS

frame	wood, solid oak, aged oak, beech
frame finishing	lacquered
table top	wood, solid oak, aged oak, beech

EXTRA

stackable	no
outdoor	no
others	metal, steel footrest

COLOURS

frame / table top	walnut, classic walnut, wenge, mahogany, cognac, classic honey, blank, matte blank, carbon, clay
-------------------	--

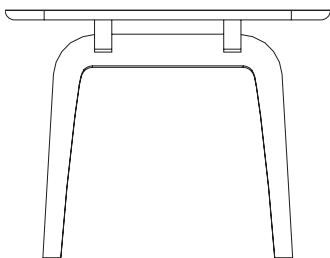

80 - 100	76	120 - 300



550 SC



550 AC



550 HS

550

ORIGINAL DESIGN BY DIRK VAN SLIEDREGT

The aluminium frame, topped with a high-quality synthetic wicker seats and backrests makes this series also suitable for outdoor use. The seat and back are made of the plastic HDPE. The frame is made of aluminium with a coating.

MATERIALS

frame	metal, aluminium
frame finishing	powder coated
seat / back	rattan look, HDPE wickerwork

EXTRA

stackable	no
outdoor	yes

COLOURS

frame	black
seat / back	black, natural

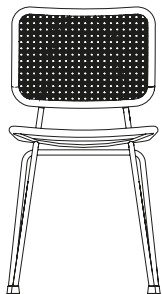

h h A h
86 51 46 47

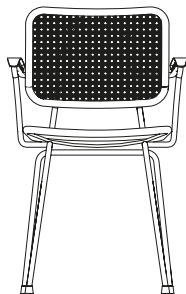

h h A h
86 51 46 47

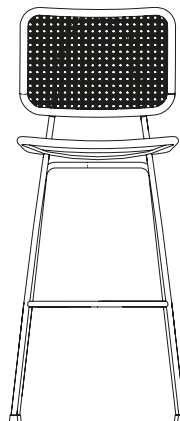
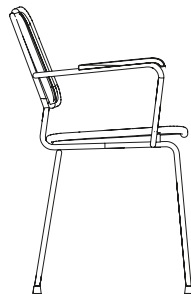

h h A h
119 51 46 80



S-17 SC

S-17 AC

S-17 HS

S-17 TB

S-17

ORIGINAL DESIGN BY PAUL PHILIPSEN

S-17 has a steel frame and a carbon wood seat and back. Even the iconic caps of the chair fit onto the newer versions of the S-17 chairs. The chair is stackable if no upholstery has been applied and also available with armrests. The stool and table complete this special series. The frame, back and seat can be made in different colours. The seat and back can also be upholstered with a fabric of your choice.

MATERIALS

frame	metal, steel
frame finishing	powder coated
seat / back	carbon wood / upholstered, flat
armrests	carbon wood

EXTRA

stackable	yes
outdoor	no

COLOURS

frame	black, cement grey, white
seat / back	black, ebony, reddish brown, white / fabric or leather, Satelliet collection or supplier

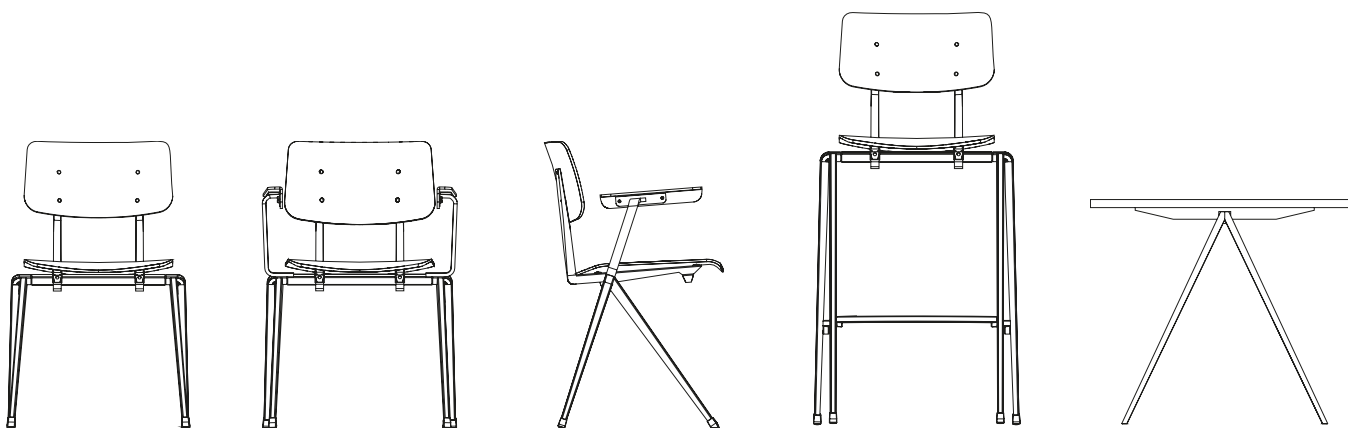

h h A h
80 50 54 46

h h A h
82 62 56 46

h h A h
115 62 54 78

□ □ □
80 - 100 73 120 - 220

Be an

Check our complete collection:
satellietoriginals.net



SATELLIETORIGINALS



SATELLIET_ORIGINALS



SATELLIET_ORIGINALS

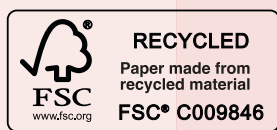

All shown pictures can deviate from reality. Variations possible to actual finish and sizes.
Misprints or printing errors with reservation.

This magazine contains a selection of the Satelliet Originals collection. Discover all the possibilities at www.satellietoriginals.net



original.

Be an original.

SATELLIET[®]
ORIGINALS

satellietoriginals.net