

# E SERIES

ELECTRIC BOOM LIFTS



## Performance

Platform Height		
E300AJP	29 ft 5 in.	8.96 m
E400AJPN	40 ft	12.19 m
E450AJ	45 ft	13.72 m
Horizontal Outreach		
E300AJP	20 ft 1 in.	6.12 m
E400AJPN	22 ft 5 in.	6.83 m
E450AJ	23 ft 9 in.	7.24 m
Up and Over Height		
E300AJP	13 ft 2 in.	4.01 m
E400AJPN	21 ft 6 in.	6.55 m
E450AJ	25 ft 3 in.	7.7 m
Swing		
E300AJP	350° Non-continuous	
E400AJPN/E450AJ	360° Non-continuous	
Platform Capacity	500 lb	227 kg
Platform Rotator	180° Hydraulic	
Weight		
E300AJP	15,705 lb	7,123 kg
E400AJPN	14,900 lb	6,759 kg
E450AJ	14,400 lb	6,532 kg
Ground Bearing Pressure		
E300AJP	170 psi	11.95 kg/cm <sup>2</sup>
E400AJPN	185 psi	13 kg/cm <sup>2</sup>
E450AJ	110 psi	7.6 kg/cm <sup>2</sup>
Max Drive Speed		
E300AJP	4.5 mph	7.2 km/h
E400AJPN	4.5 mph	7.2 km/h
E450AJ	4.5 mph	7.2 km/h
Gradeability		
E300AJP	25%	
E400AJPN	30%	
E450AJ	30%	
Turning Radius (inside)		
E300AJP	5 ft	1.52 m
E400AJPN	2 ft 10 in.	.86 m
E450AJ	2 ft	.61 m
Turning Radius (outside)		
E300AJP	10 ft 2 in.	3.1 m
E400AJPN	10 ft 4 in.	3.15 m
E450AJ	10 ft 4 in.	3.15 m

## Standard Specifications

### Power Source

Electrical System	48V DC	
Batteries	8 x 6V, 370 amp-hr (305 amp-hr on E300)	
Drive Motors	Dual Electric Traction—Brushless AC	
Generator Set (M Models)		
Diesel Engine Kubota 45 amp	6.7 hp	4.99 kW
Fuel Tank Capacity	4 gal.	15.2 L

### Hydraulic System

• E300AJP	21 gal.	7.95 L
• E400AJPN	4 gal.	15.14 L
• E450AJ	4 gal.	15.14 L
• Motor/Pump	Permanent Magnet Motor/Gear Pump	



### Tires

• E300AJP	25 x 7 x 12 Non-marking Foam Filled
• E400AJPN (front)	22 x 6 x 17.5 Non-marking Foam Filled
• E400AJPN (rear)	25 x 7 x 12 Non-marking Foam Filled
• E450AJ	240/55-17.5 Foam Filled

### Standard Features

• Automatic Traction Control (ATC)	• Lifting/Tie Down Lugs
• Side Entry Platform	• Horn
• 180 Degree Hydraulic Platform Rotator	• All Motion Alarm
• 110V-AC Receptacle on Platform	• Eight 6V 370 amp-hr Deep Cycle Batteries
• Tilt Light and Alarm	• Brushless AC Motors
• Hourmeter	• Load Sensing System
• Battery Condition Indicator	• SkyGuard Skyline™

### Accessories & Options

• Inward Self-closing Swing Gate	• UL® EE Rating <sup>2</sup>
• SkySense™ (E450AJ Only)	• Flashing Amber Beacon
• Hostile Environment Package <sup>1</sup>	• Operator Tool Tray

1. Includes boom wipers, cylinder bellows and console cover.  
2. Not available on Multi-powered models.

Additional accessories and options available via JLG Aftermarket.

# E SERIES

ELECTRIC BOOM LIFTS



## Dimensions

All dimensions are approximate.

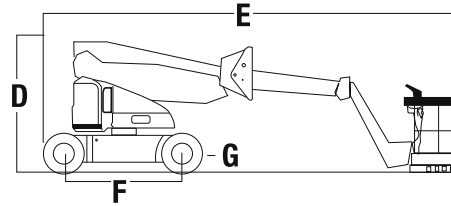
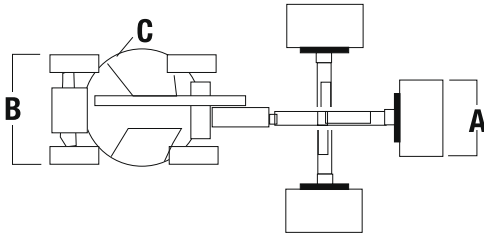

### A. Platform Size

E300AJP	30 x 48 in.	0.76 x 1.22 m
E400AJPN	30 x 48 in.	0.76 x 1.22 m
E450AJ	30 x 60 in.	0.76 x 1.52 m

### C. Tailswing

E300AJP	Zero	
E400AJPN	4 in.	10 cm
E450AJ	Zero	

### E. Stowed Length

E300AJP	18 ft 10 in.	5.74 m
E400AJPN	22 ft	6.71 m
E450AJ	21 ft 2 in.	6.45 m

### G. Ground Clearance

E300AJP	4 in.	10 cm
E400AJPN	5 in.	13 cm
E450AJ	8 in.	20 cm

### B. Overall Width

E300AJP	4 ft	1.22 m
E400AJPN	4 ft 11 in.	1.5 m
E450AJ	5 ft 9 in.	1.75 m

### D. Stowed Height

E300AJP	6 ft 7 in.	2.01 m
E400AJPN	6 ft 5.75 in.	1.97 m
E450AJ	6 ft 7 in.	2.01 m

### F. Wheelbase

E300AJP	5 ft 5 in.	1.65 m
E400AJPN	6 ft 7 in.	2.01 m
E450AJ	6 ft 7 in.	2.01 m

## Reach Diagrams

### E300

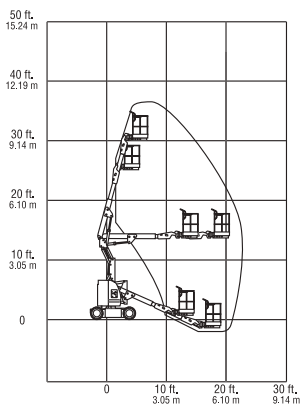

### E400

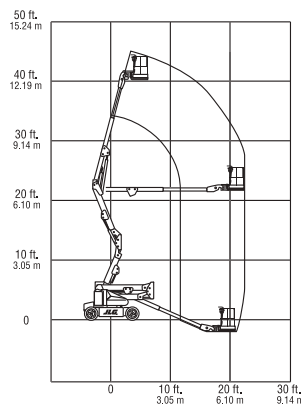

### E450

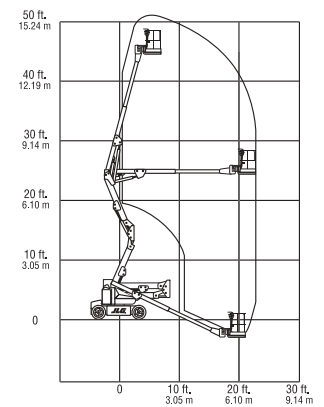

## The JLG "1 & 5" Warranty

We provide coverage for one (1) full year, and cover all specified major structural components for five (5) years. Due to continuous product improvements, we reserve the right to make specification and/or equipment changes without prior notification. This machine meets or exceeds applicable ANSI and CSA requirements based on machine configuration as originally manufactured for intended applications. Please reference the serial number plate on the machine for additional information.

Part No.: 3131119  
R1219\_A92.20  
Printed in USA

**JLG Industries, Inc.**  
1 JLG Drive  
McConnellsburg, PA 17233-9533  
Telephone 717-485-5161  
Toll-free in US 877-JLG-LIFT  
Fax 717-485-6417  
[www.jlg.com](http://www.jlg.com)

**An Oshkosh Corporation Company**