

# Profilink Speciality system

Opening system without thermal break

**Technical catalogue**



# CONTENT

System overview _____	4
List of profiles _____	5
Profiles _____	9
Typologies _____	17
Sections _____	19
Glazing options _____	75
Machining _____	77
Accessories _____	91

## System overview

Optimized non insulated aluminium system for light and economical solutions for windows and doors with an excellent value for money.

Suitable for the implementation of interior doors, internal partitions and showcases. The design of the system allows extremely fast and efficient assembly in the production of frames.

## WINDOW SYSTEM



## DOOR SYSTEM



### TECHNICAL FEATURES

- Frame parameters: W-37.5 and 74 mm, H-47 and 57 mm
- Casement parameters: W-45 mm, H-62 and 94 mm
- Glazing options: 4, 10 and 20 mm

### SURFACE OPTIONS

- All RAL colors
- Anodizing
- Lamination

### HARDWARE OPTIONS

- EURO groove channel



# List of profiles



# Profilink Speciality system

Opening system without thermal break

profile code		perimeter mm		Ix - cm <sup>4</sup>	Iy - cm <sup>4</sup>	profile code		perimeter mm		Ix - cm <sup>4</sup>	Iy - cm <sup>4</sup>
		primary	external					primary	external		

PLAWC.38.101	6.00	77 mm	244 mm	-	-	PLAWC.45.202	6.00	145 mm	379 mm	-	-
--------------	------	-------	--------	---	---	--------------	------	--------	--------	---	---

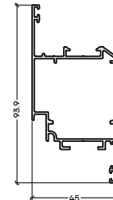
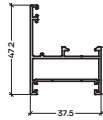

PLAWC.38.102	6.00	92 mm	265 mm	-	-	PLAWC.45.203	6.00	145 mm	379 mm	-	-
--------------	------	-------	--------	---	---	--------------	------	--------	--------	---	---

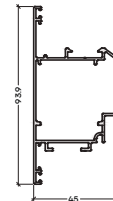
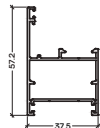

PLAWC.38.103	6.00	114 mm	333 mm	-	-	PLAWC.38.303	6.00	242 mm	717 mm	-	-
--------------	------	--------	--------	---	---	--------------	------	--------	--------	---	---

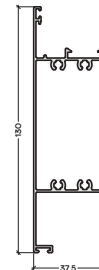
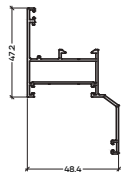

PLAWC.38.104	6.00	127 mm	346 mm	-	-	PLAWC.38.301	6.00	116 mm	465 mm	-	-
--------------	------	--------	--------	---	---	--------------	------	--------	--------	---	---

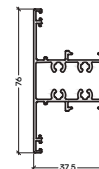
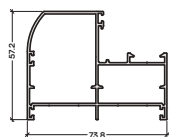

PLAWC.45.201	6.00	82 mm	312 mm	-	-	PLAWC.38.302	6.00	98 mm	322 mm	-	-
--------------	------	-------	--------	---	---	--------------	------	-------	--------	---	---

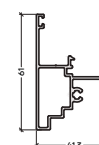
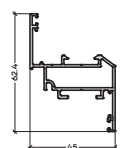

profile code		perimeter mm		Ix - cm <sup>4</sup>	Iy - cm <sup>4</sup>	profile code		perimeter mm		Ix - cm <sup>4</sup>	Iy - cm <sup>4</sup>
		primary	external					primary	external		

PLAAC.39.501	6.00	77 mm	157 mm	-	-	PLAGC.17.601	6.00	39 mm	146 mm	-	-
--------------	------	-------	--------	---	---	--------------	------	-------	--------	---	---

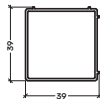

PLAAG.40.501	6.00	126 mm	126 mm	-	-	PLAGC.23.601	6.00	45 mm	160 mm	-	-
--------------	------	--------	--------	---	---	--------------	------	-------	--------	---	---



PLAAC.37.501	6.50	72 mm	142 mm	-	-
--------------	------	-------	--------	---	---



PLAAC.43.501	6.00	66 mm	260 mm	-	-
--------------	------	-------	--------	---	---

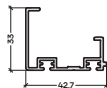

PLAGC.07.601	6.00	28 mm	131 mm	-	-
--------------	------	-------	--------	---	---





The background features several overlapping, semi-transparent teal shapes. A prominent yellow line forms a large, irregular shape on the left side, consisting of a vertical line, a horizontal line, a diagonal line, and another vertical line. The word "Profiles" is written in a bold, dark teal font on the right side of the page.

# Profiles



**PLAWC.38.101**

Frame

545 gr/m

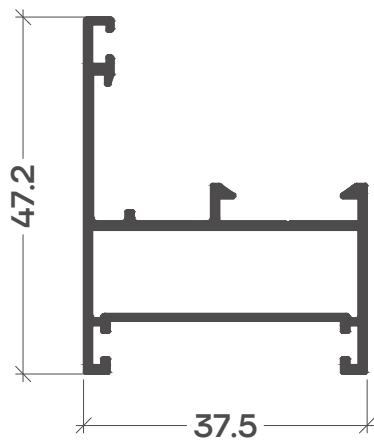

**PLAWC.38.102**

Frame

648 gr/m

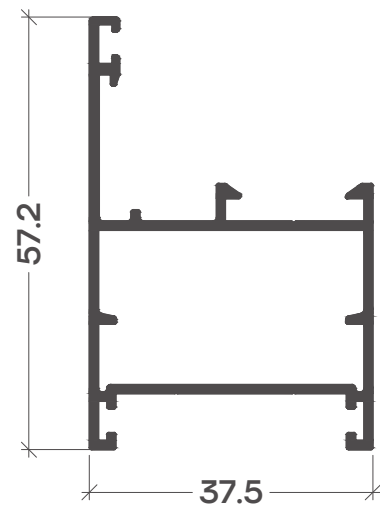

**PLAWC.38.103**

Frame

683 gr/m

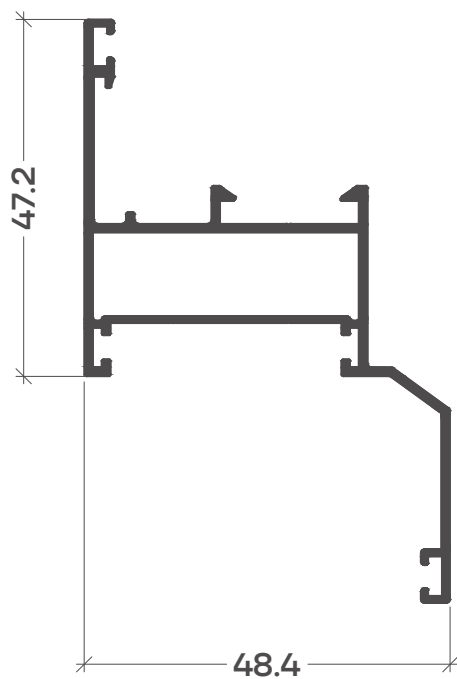

**PLAWC.38.104**

Frame

1093 gr/m

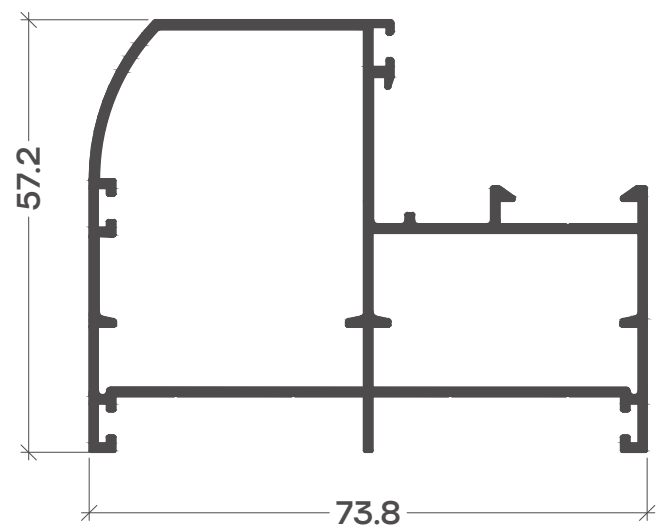

**PLAWC.45.201**

Sash  
694 gr/m

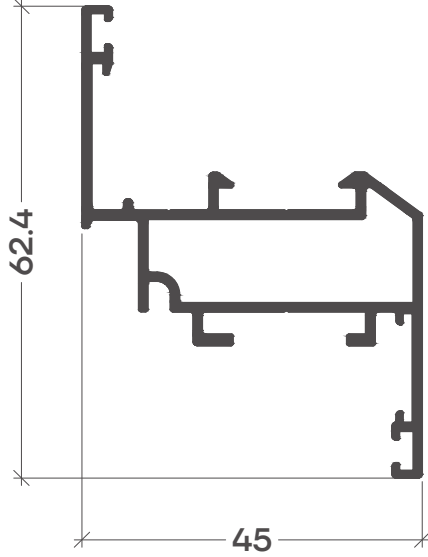

**PLAWC.45.202**

Sash  
964 gr/m

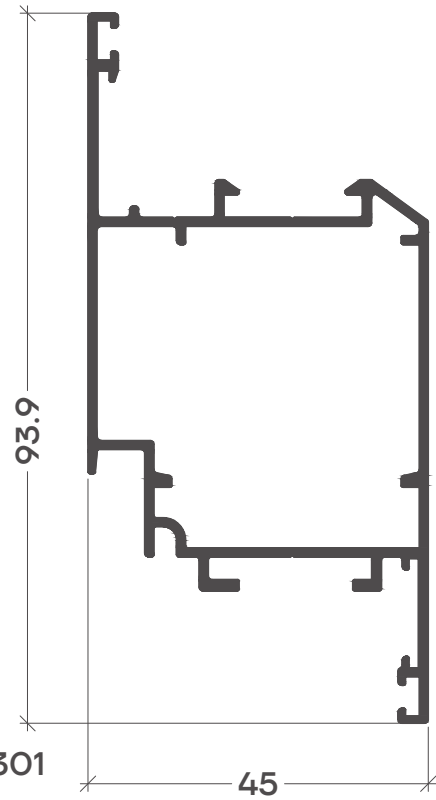

**PLAWC.45.203**

Sash  
967 gr/m

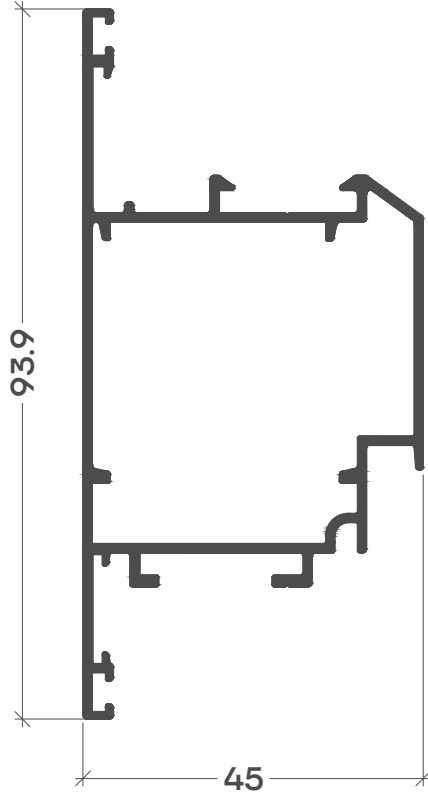

**PLAWC.38.301**

Mullion  
934 gr/m

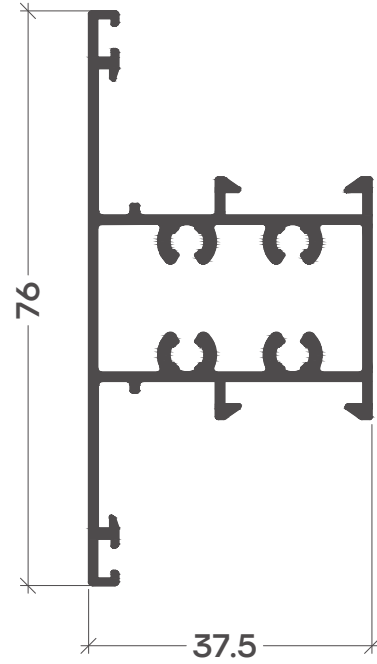

**PLAWC.38.302**

Overhung

737 gr/m

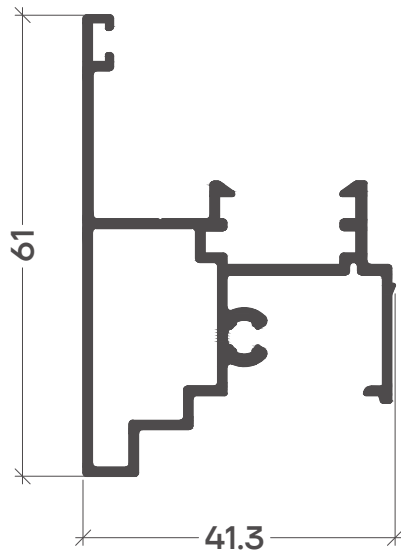

**PLAWC.38.303**

Kick-plate

1350 g/m

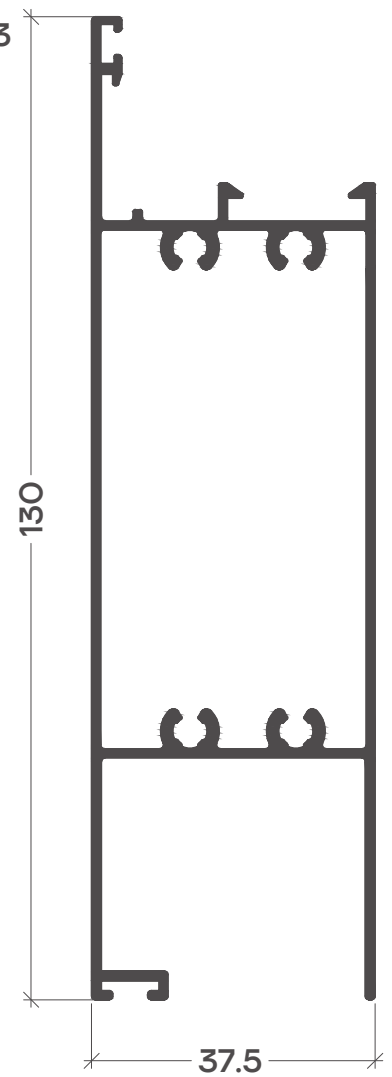

**PLAAC.43.501**

Ending profile

481 gr/m

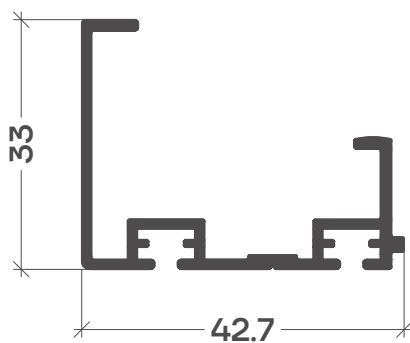

**PLAAC.39.501**

Column

486 gr/m

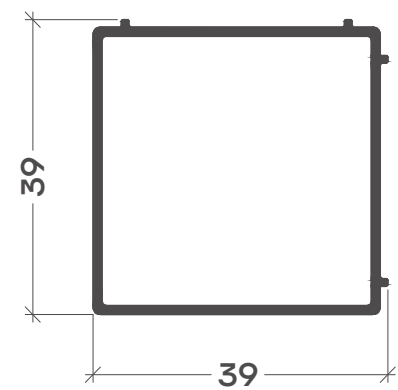

**PLAAO.40.501**  
Pipe  
394 gr/m

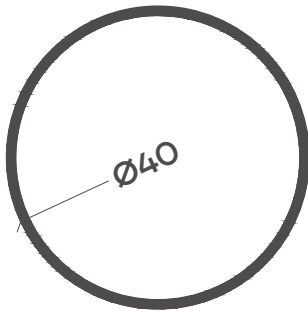

**PLAAC.37.501**  
Adaptor  
243 gr/m

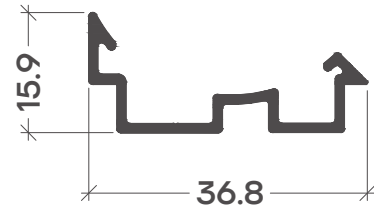

**PLAGC.17.601**  
Glassbead  
243 gr/m

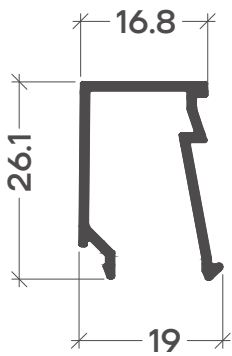

**PLAGC.07.601**  
Glassbead  
221 gr/m

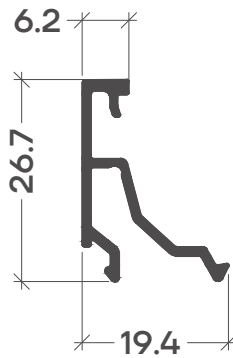

**PLAGC.23.601**  
Glassbead  
265 gr/m

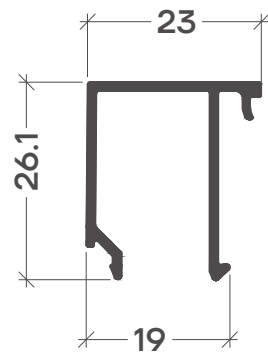

The background is a solid dark teal color. It features several abstract, overlapping geometric lines in a lighter teal and a bright yellow. These lines form various shapes, including rectangles, triangles, and irregular polygons, some with rounded corners. The lines are positioned in the top right, bottom left, and bottom right areas of the page, creating a modern, architectural feel.

# Typologies





## Windows

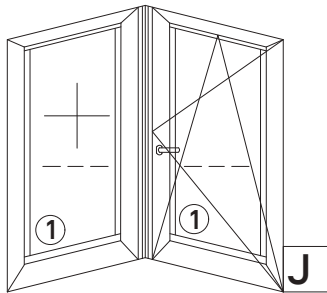
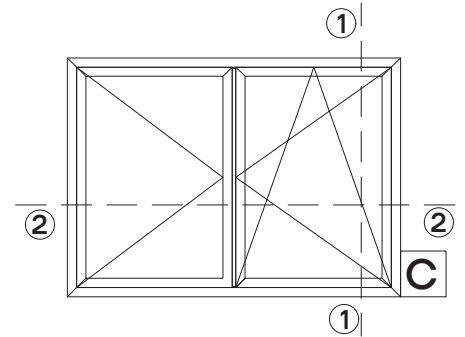
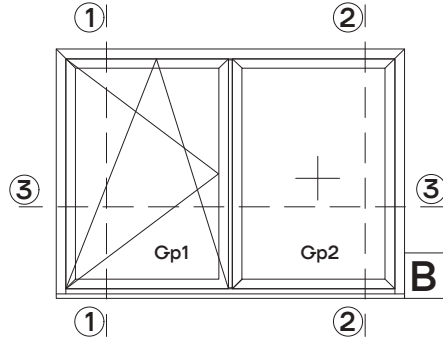
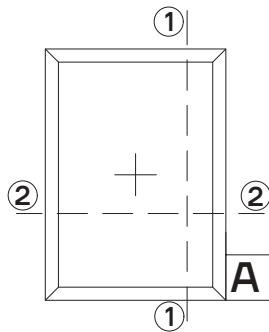

## Doors

### outward opening door

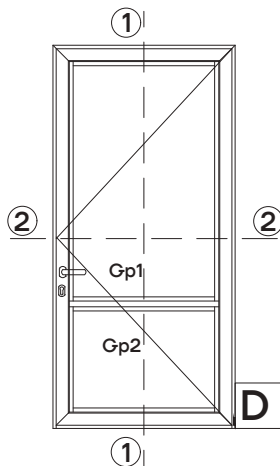

### inward opening door

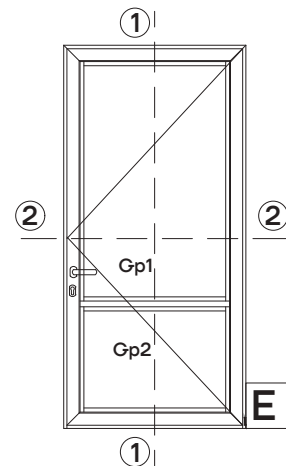

**Doors**

**outward opening door**

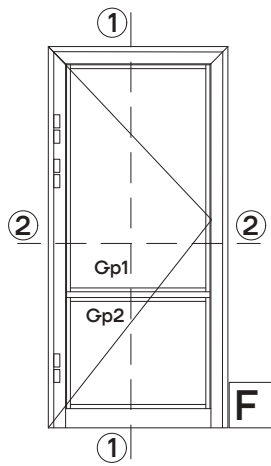

**inward opening door**

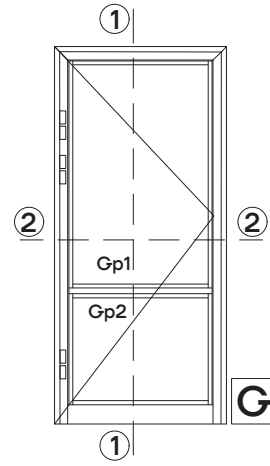

**outward opening door**

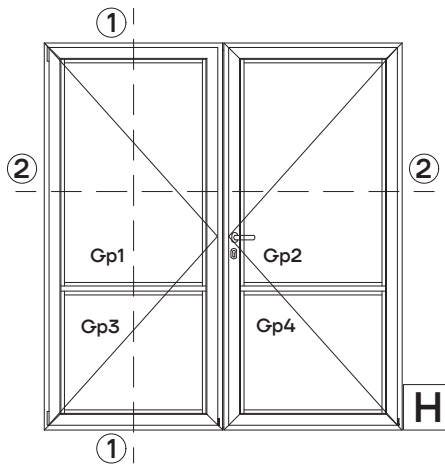

**inward opening door**

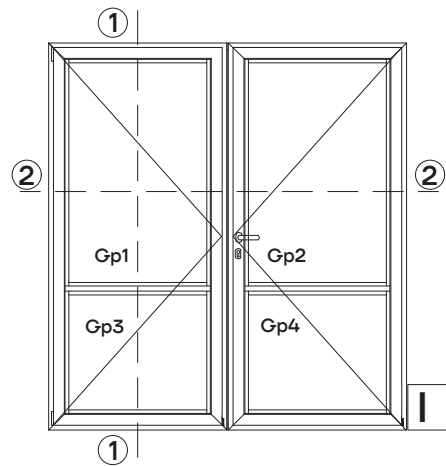

The background is a solid teal color. It features several thin, yellow lines that form abstract, geometric shapes. These lines are composed of straight segments connected at various angles, creating a sense of movement and depth. The lines vary in length and orientation, some running parallel to each other and others intersecting. The overall effect is a modern, minimalist design.

# Sections







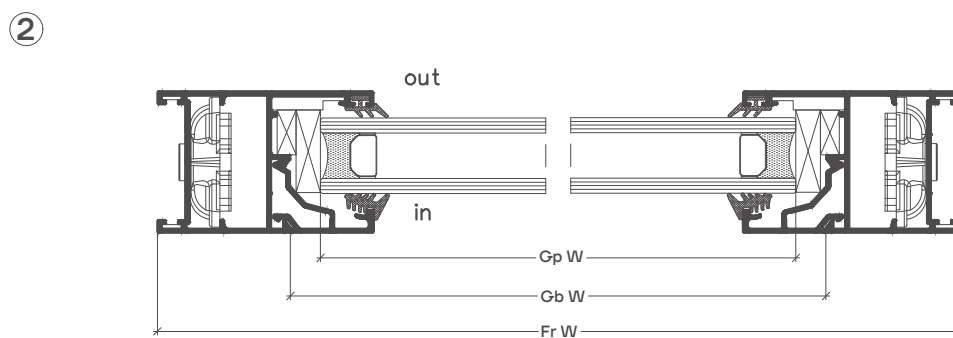
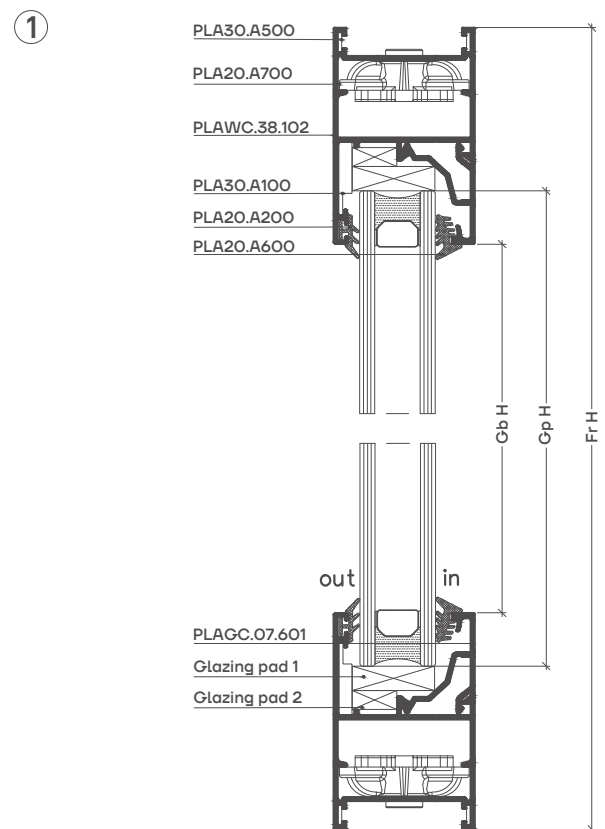
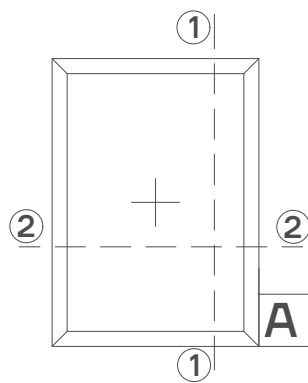

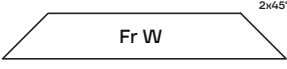
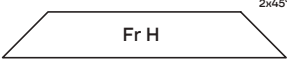
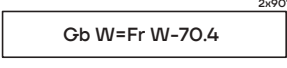
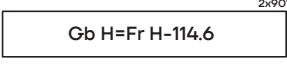
# Profilink Speciality system

Opening system without thermal break



Cuttings and quantities		
Code	Formula	Quantity
PLAWC.38.102 frame width	 $Fr W$	2 pcs
PLAWC.38.102 frame height	 $Fr H$	2 pcs
PLAGC.07.601 glazing bead width	 $Gb W=Fr W-70.4$	2 pcs
PLAGC.07.601 glazing bead height	 $Gb H=Fr H-114.6$	2 pcs
glass pane W/H	$Gp W=Fr W-86.4/$ $Gp H=Fr H-86.4$	1 pcs

Accessory list			
Code	Accessory	Description	Quantity
PLA20.A200		external gasket	2Gb W+2Gb H
PLA20.A600		internal gasket	2Gb W+2Gb H
PLA20.A700		alignment corner	4 pcs
PLA30.A100		alignment square with locking function	4 pcs
PLA30.A500		alignment corner	8 pcs
		glazing pad 1	4 pcs
		glazing pad 2	4 pcs

# Proflink Speciality system

Opening system without thermal break

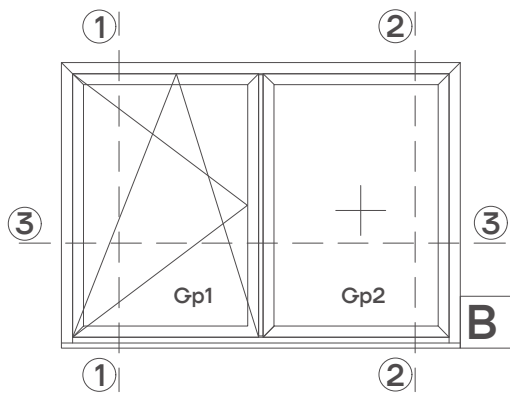

②

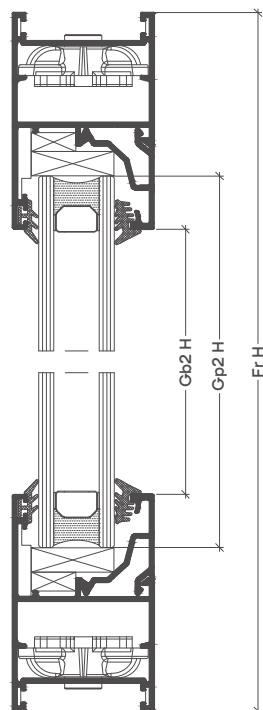

①

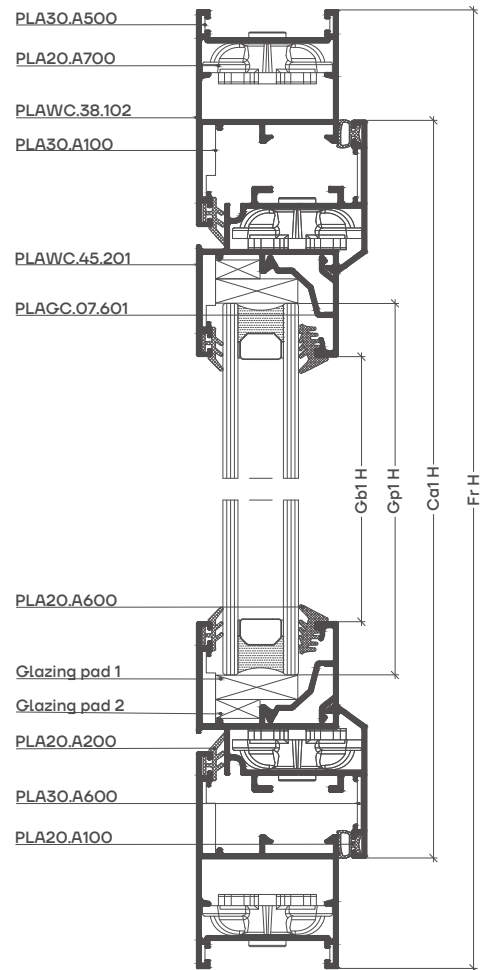

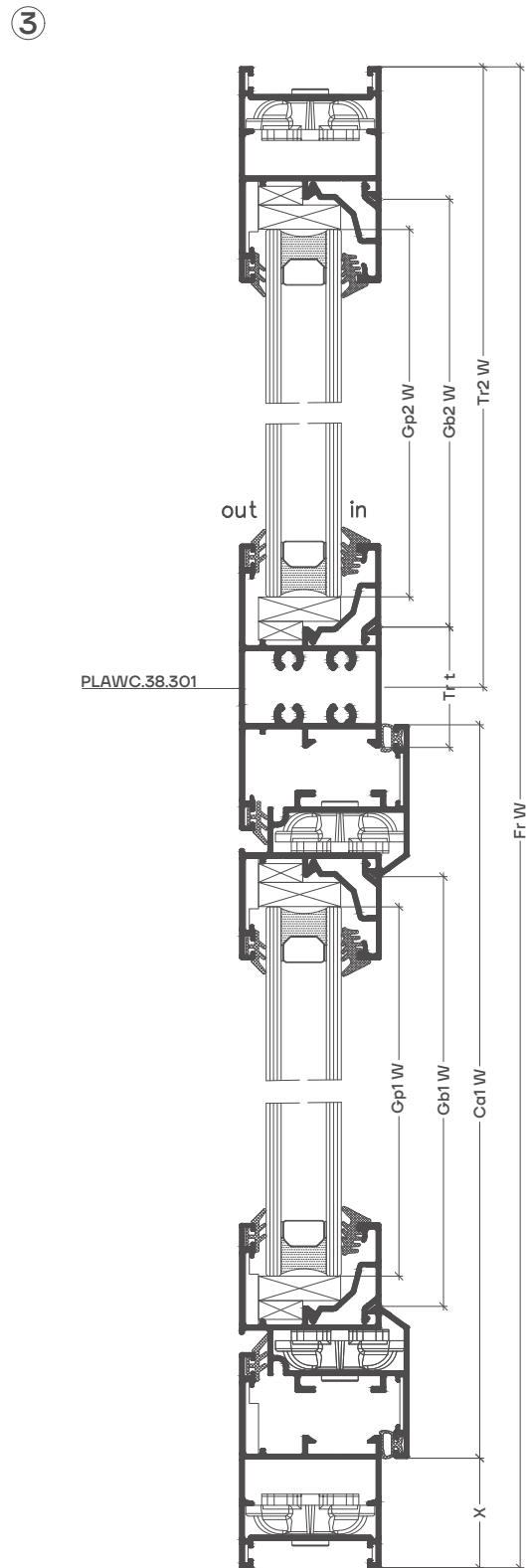
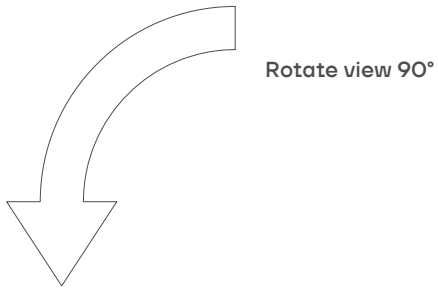
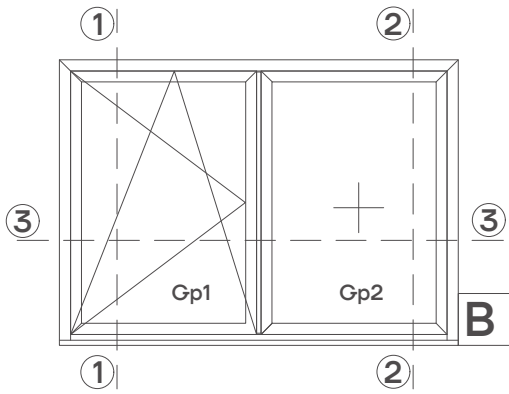









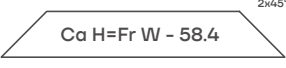
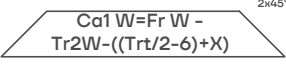
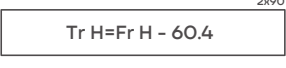
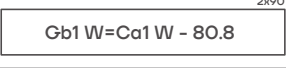
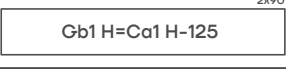
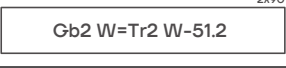
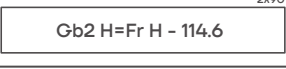





# Profilink Speciality system

Opening system without thermal break

Cuttings and quantities		
Code	Formula	Quantity
PLAWC.38.102 frame width	 $Fr\ W$	2 pcs
PLAWC.38.102 frame height	 $Fr\ H$	2 pcs
PLAWC.45.201 casement height	 $Ca\ H=Fr\ W - 58.4$	2 pcs
PLAWC.45.201 casement width	 $Ca1\ W=Fr\ W - Tr2W - ((Trt/2 - 6) + X)$	2 pcs
PLAWC.38.301 T profile	 $Tr\ H=Fr\ H - 60.4$	1 pcs
PLAGC.07.601 glazing bead width	 $Gb1\ W=Ca1\ W - 80.8$	2 pcs
PLAGC.07.601 glazing bead height	 $Gb1\ H=Ca1\ H - 125$	2 pcs
PLAGC.07.601 glazing bead width	 $Gb2\ W=Tr2\ W - 51.2$	2 pcs
PLAGC.07.601 glazing bead height	 $Gb2\ H=Fr\ H - 114.6$	2 pcs
glass pane 1 W/H	$Gp1\ W=Ca1\ W - 96.8$ $Gp1\ H=Ca1\ H - 96.8$	1 pcs
glass pane 2 W/H	$Gp2\ W=Tr2\ W - 67.2$ $Gp2\ H=Ca\ H - 86.4$	1 pcs

Accessory list			
Code	Accessory	Description	Quantity
PLA20.A200		external gasket	2Gb W+2Gb H
PLA20.A600		internal gasket	2Gb W+2Gb H
PLA20.A100		internal gasket	2Ca1 W+2Ca1 H
PLA20.A700		alignment corner	8 pcs
PLA30.A100		alignment square with locking function	8 pcs
PLA30.A500		alignment corner	8 pcs
PLA30.A600		alignment corner	4 pcs
		glazing pad 1	8 pcs
		glazing pad 2	8 pcs

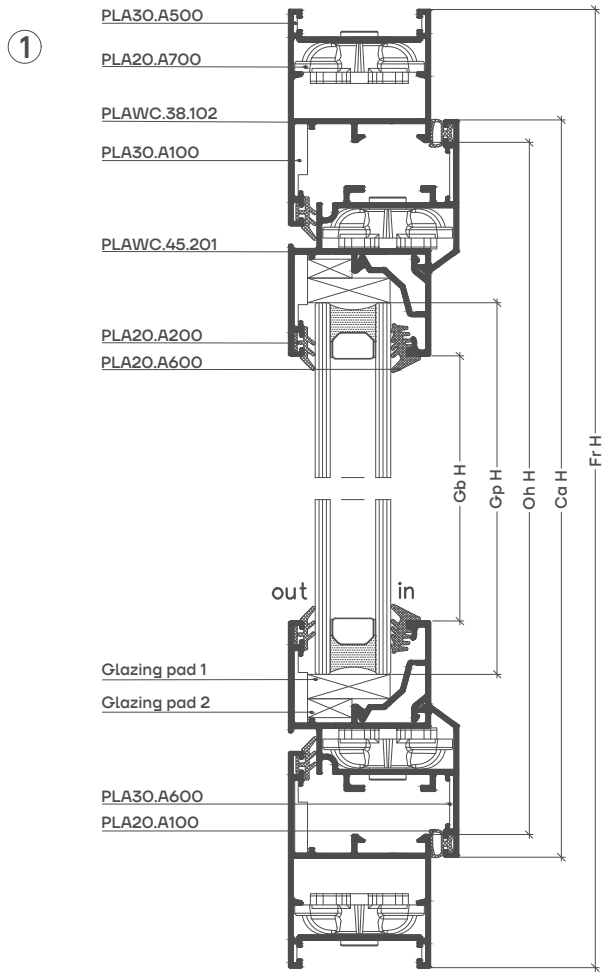
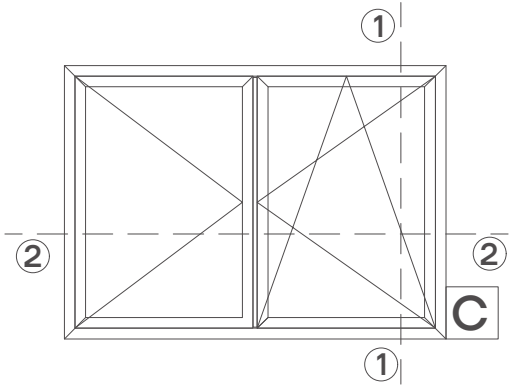



# Proflink Speciality system

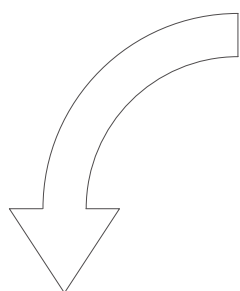
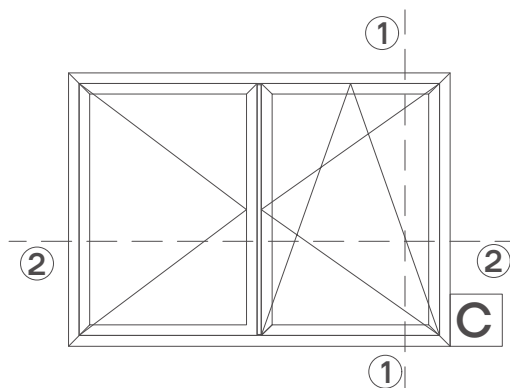



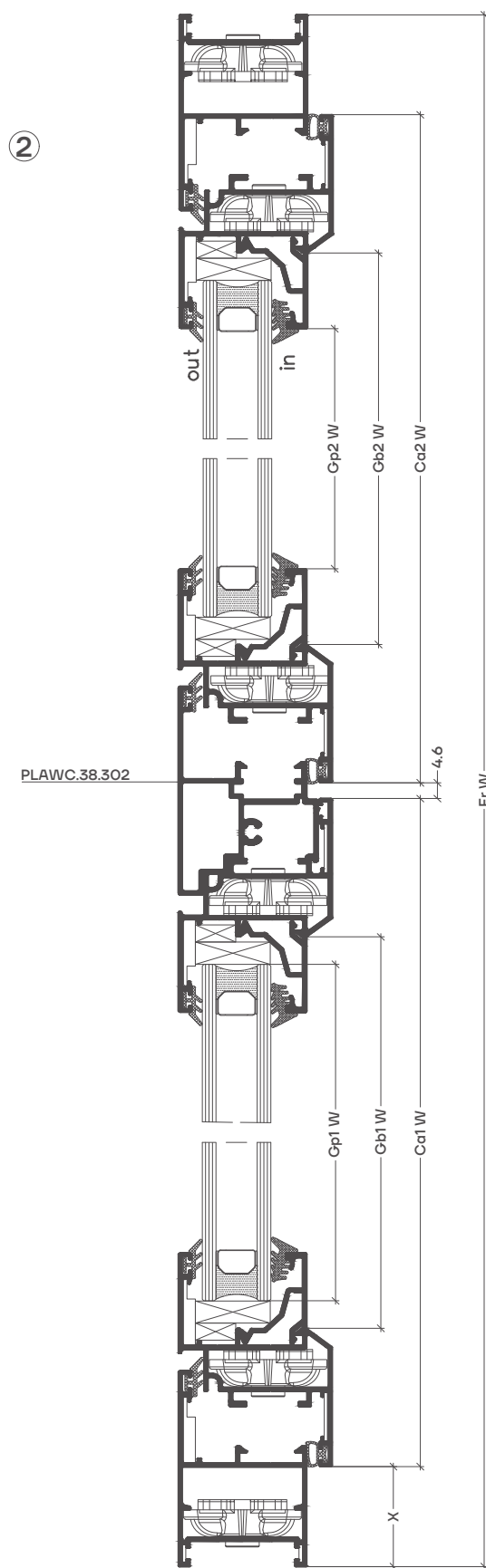



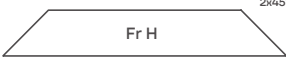
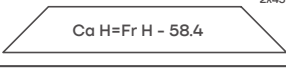
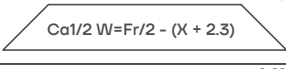
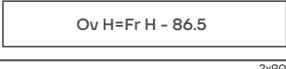
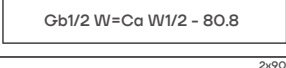
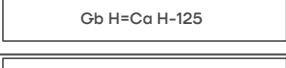

Opening system without thermal break



Rotate view 90°



Cuttings and quantities		
Code	Formula	Quantity
PLAWC.38.102 fame width	 $Fr\ W$	2 pcs
PLAWC.38.102 frame height	 $Fr\ H$	2 pcs
PLAWC.45.201 casement height	 $Ca\ H = Fr\ H - 58.4$	4 pcs
PLAWC.45.201 casement width	 $Ca\ 1/2\ W = Fr/2 - (X + 2.3)$	4 pcs
PLAWC.38.302 overhung	 $Ov\ H = Fr\ H - 86.5$	1 pcs
PLAGC.07.601 glazing bead width	 $Gb\ 1/2\ W = Ca\ W/2 - 80.8$	4 pcs
PLAGC.07.601 glazing bead height	 $Gb\ H = Ca\ H - 125$	4 pcs
glass pane 1 W/H	$Gp1\ W = Ca1\ W - 96.8$ $Gp1\ H = Ca\ H - 96.8$	1 pcs
glass pane 2 W/H	$Gp2\ W = Ca2\ W - 96.8$ $Gp2\ H = Ca\ H - 96.8$	1 pcs

Accessory list			
Code	Accessory	Description	Quantity
PLA20.A200		external gasket	2Gb W+2Gb H
PLA20.A600		internal gasket	2Gb W+2Gb H
PLA20.A100		internal gasket	2Ca1 W+Ca1 H 2Ca2 W+2Ca2 H
PLA20.A700		alignment corner	12 pcs
PLA30.A100		alignment square with locking function	12 pcs
PLA30.A500		alignment corner	8 pcs
PLA30.A600		alignment corner	8 pcs
PLA10.A100		cap for overhung	1 set
PLA30.A300		alignment corner	4 pcs
		glazing pad 1	8 pcs
		glazing pad 2	8 pcs

## outward opening door

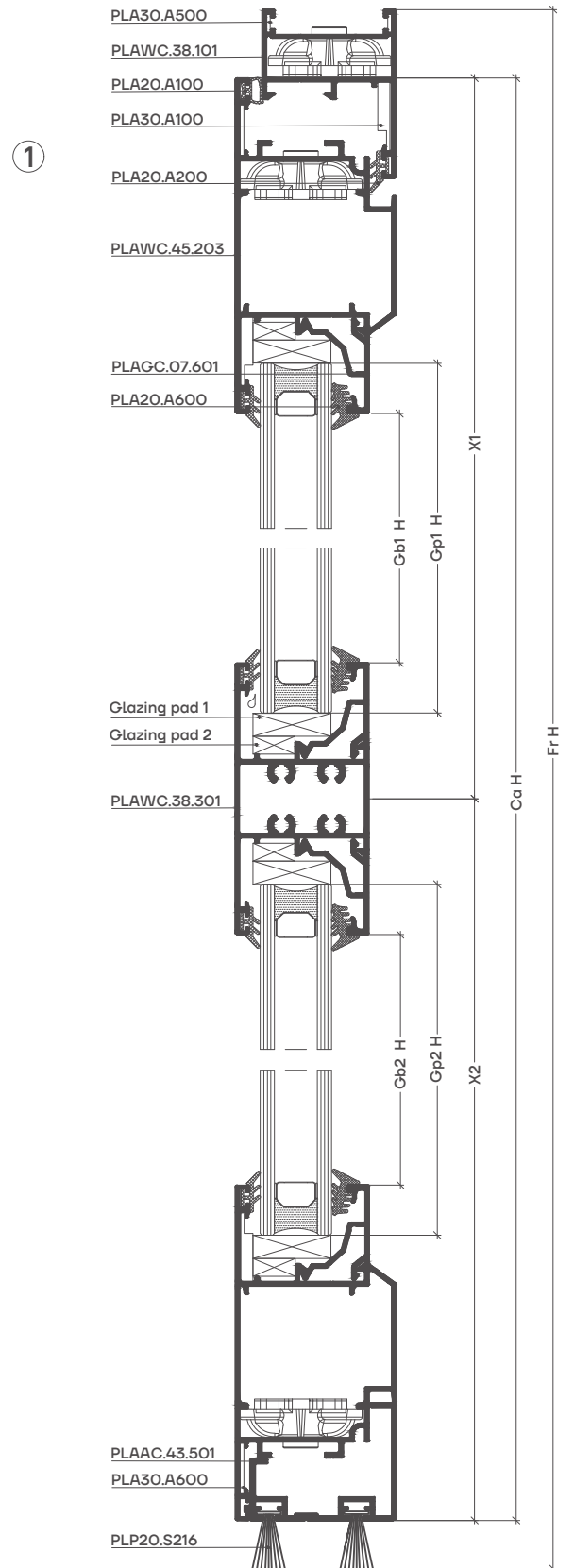
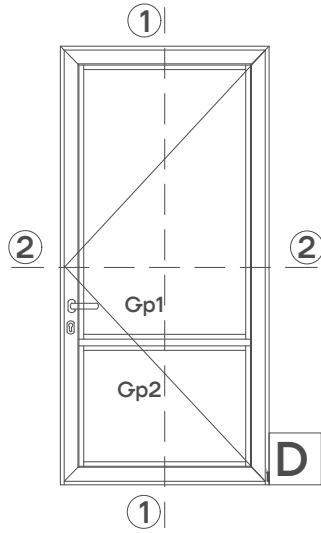



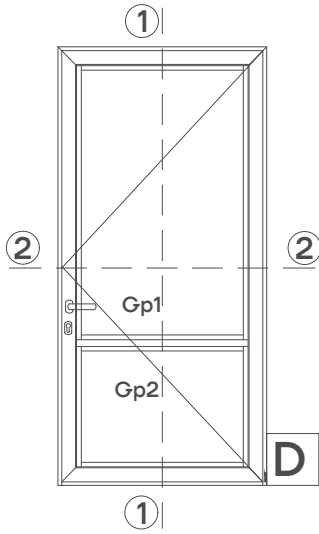



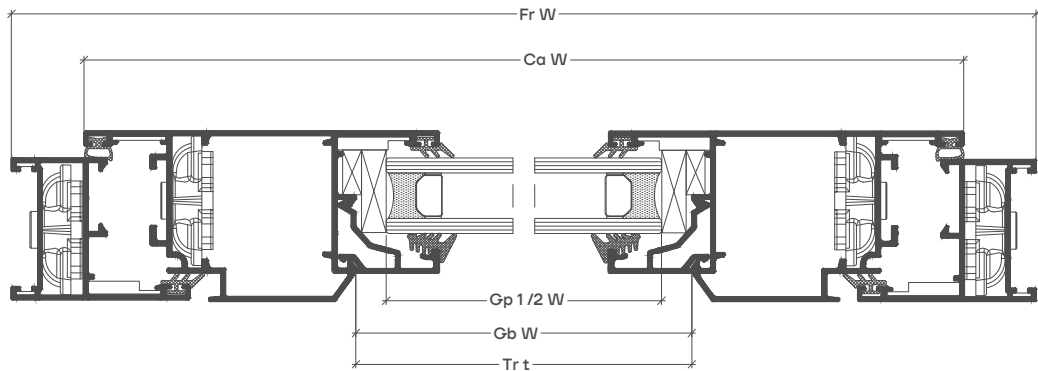



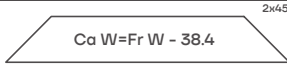
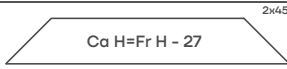
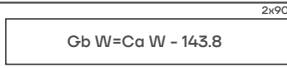
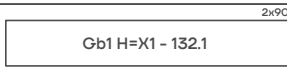
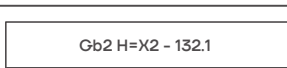
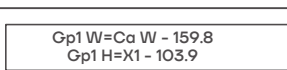
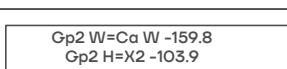
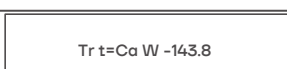
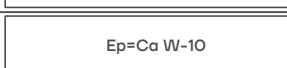



outward opening door



2



Cuttings and quantities		
Code	Formula	Quantity
PLAWC.38.101 fame width	 Fr W	1 pcs
PLAWC.38.101 frame height	 Fr H	2 pcs mirror
PLAWC.45.203 casement width	 Ca W=Fr W - 38.4	2 pcs
PLAWC.45.203 casement height	 Ca H=Fr H - 27	2 pcs
PLAGC.07.601 glazing bead width	 Gb W=Ca W - 143.8	4 pcs
PLAGC.07.601 glazing bead height	 Gb1 H=X1 - 132.1	2 pcs
PLAGC.07.601 glazing bead height	 Gb2 H=X2 - 132.1	2 pcs
glass pane 1 W/H	 Gp1 W=Ca W - 159.8 Gp1 H=X1 - 103.9	1 pcs
glass pane 2 W/H	 Gp2 W=Ca W - 159.8 Gp2 H=X2 - 103.9	1 pcs
PLAWC.38.301 T - profile	 Tr t=Ca W - 143.8	1 pcs
PLAAC.43.501 Ending profile	 Ep=Ca W - 10	1 pcs

Accessory list			
Code	Accessory	Description	Quantity
PLA20.A200		external gasket	2Gb W+2Gb H
PLA20.A600		internal gasket	2Gb W+2Gb H
PLA20.A100		internal gasket	Ca W+2Ca H
PLA20.A700		alignment corner	6 pcs
PLA30.A100		alignment square with locking function	6 pcs
PLA30.A500		aligment corner	4 pcs
PLA30.A600		aligment corner	4 pcs
PLA10.A300		cap for ending profile	1 set
PLP20.S216		brush	2CaW-4
		glazing pad 1	8 pcs
		glazing pad 2	8 pcs

outward opening door

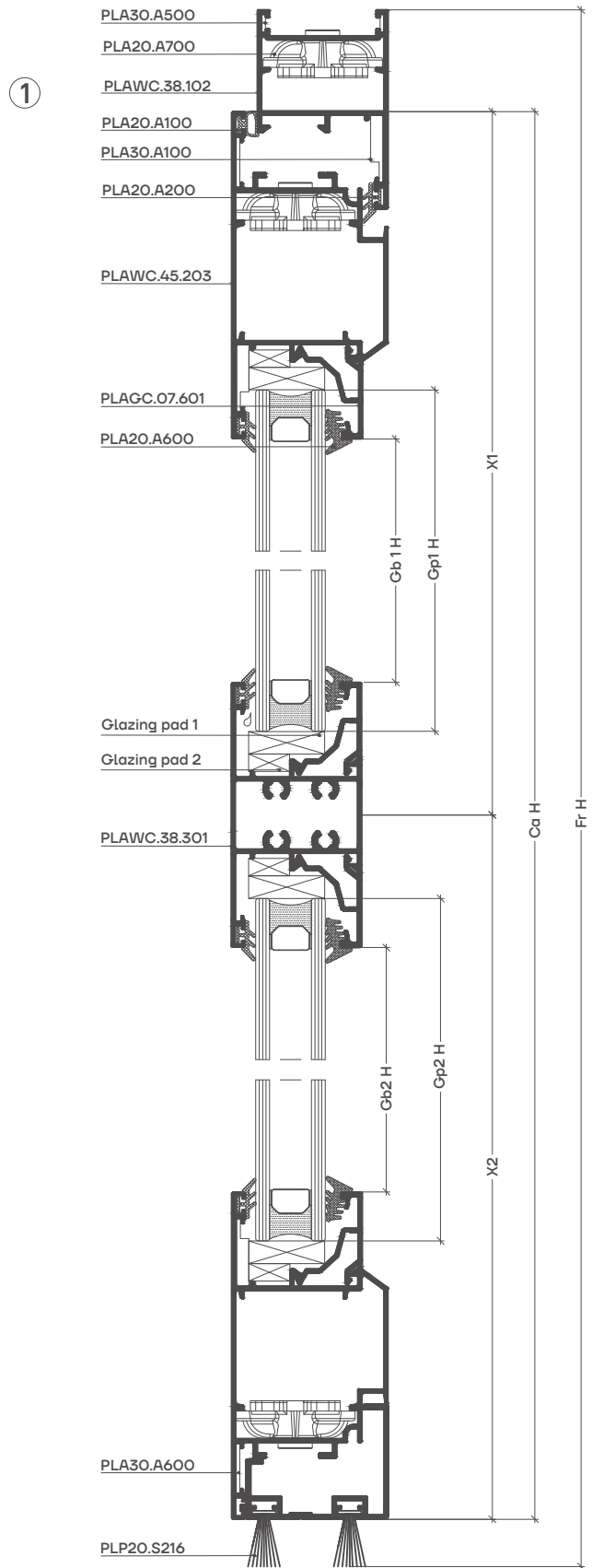
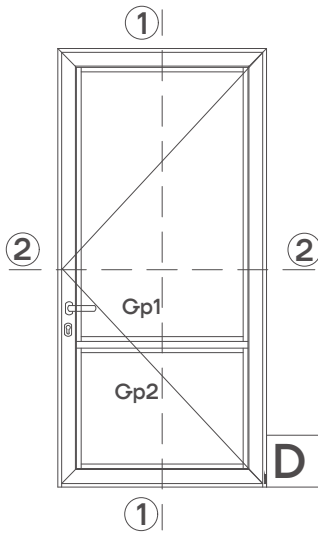





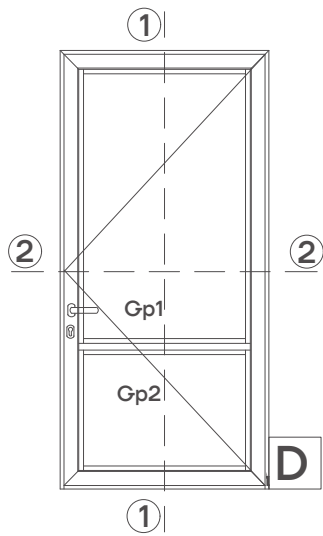



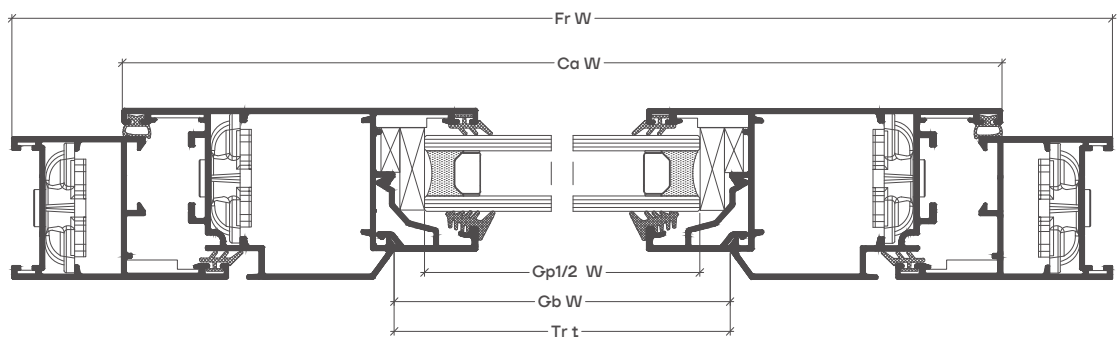



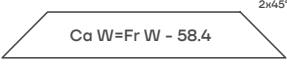
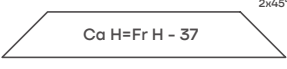
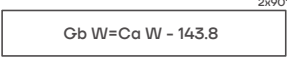
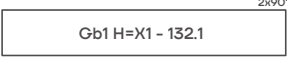
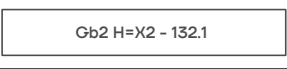



## outward opening door



②



Cuttings and quantities		
Code	Formula	Quantity
PLAWC.38.102 fame width	 $Fr\ W$	1 pcs
PLAWC.38.102 frame height	 $Fr\ H$	2 pcs mirror
PLAWC.45.203 casement width	 $Ca\ W=Fr\ W - 58.4$	2 pcs
PLAWC.45.203 casement height	 $Ca\ H=Fr\ H - 37$	2 pcs
PLAGC.07.601 glazing bead width	 $Gb\ W=Ca\ W - 143.8$	4 pcs
PLAGC.07.601 glazing bead height	 $Gb1\ H=X1 - 132.1$	2 pcs
PLAGC.07.601 glazing bead height	 $Gb2\ H=X2 - 132.1$	2 pcs
glass pane 1 W/H	$Gp1\ W=Ca\ W - 159.8$ $Gp1\ H=X1 - 103.9$	1 pcs
glass pane 2 W/H	$Gp2\ W=Ca\ W - 159.8$ $Gp2\ H=X2 - 103.9$	1 pcs
PLAWC.38.301 T - profile	$Tr\ t=Ca\ W - 143.8$	1 pcs
PLAAC.43.501 Ending profile	$Ep=Ca\ W-10$	1 pcs

Accessory list			
Code	Accessory	Description	Quantity
PLA20.A200		external gasket	2Gb W+2Gb H
PLA20.A600		internal gasket	2Gb W+2Gb H
PLA20.A100		internal gasket	Ca W+2Ca H
PLA20.A700		alignment corner	6 pcs
PLA30.A100		alignment square with locking function	6 pcs
PLA30.A500		aligment corner	4 pcs
PLA30.A600		aligment corner	4 pcs
PLA10.A300		cap for ending profile	1 set
PLP20.S216		brush	2CaW-4
		glazing pad 1	8 pcs
		glazing pad 2	8 pcs



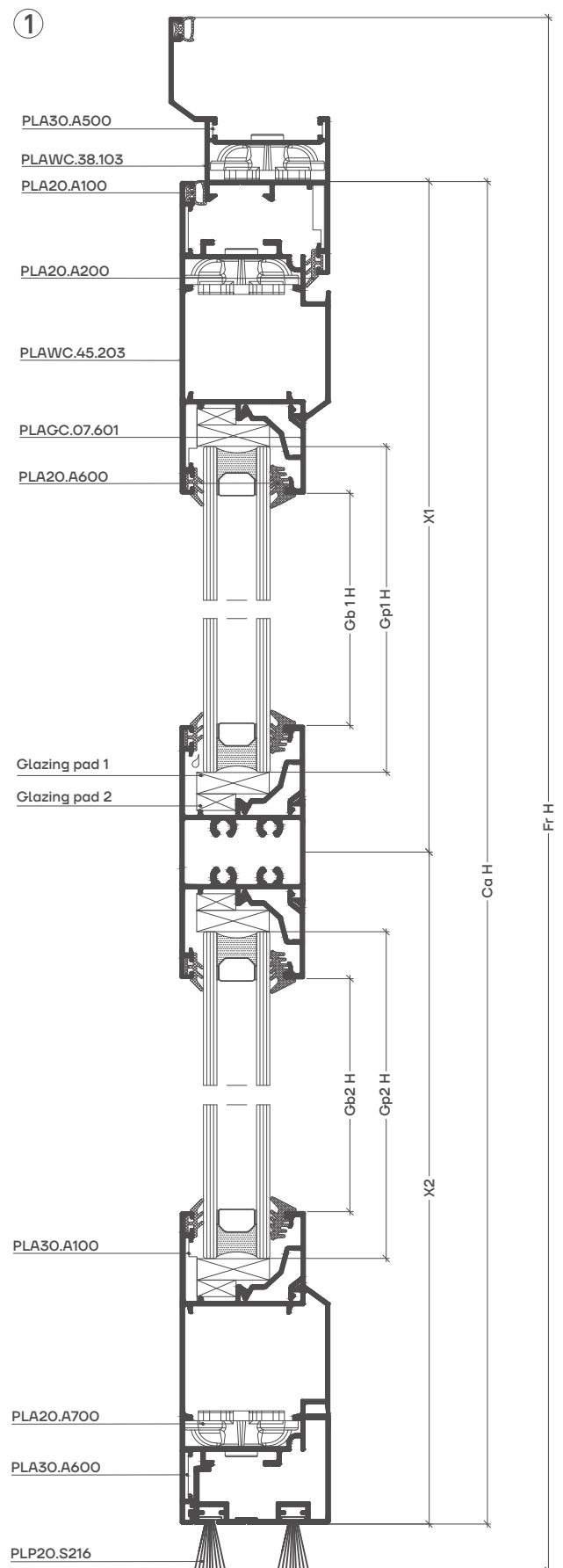
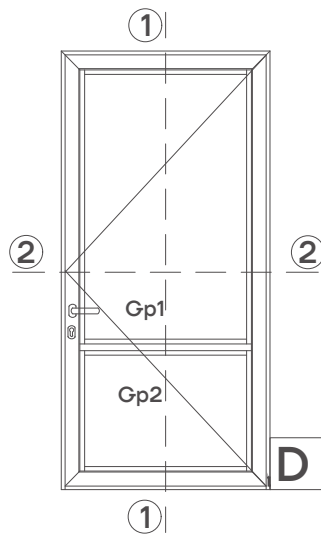



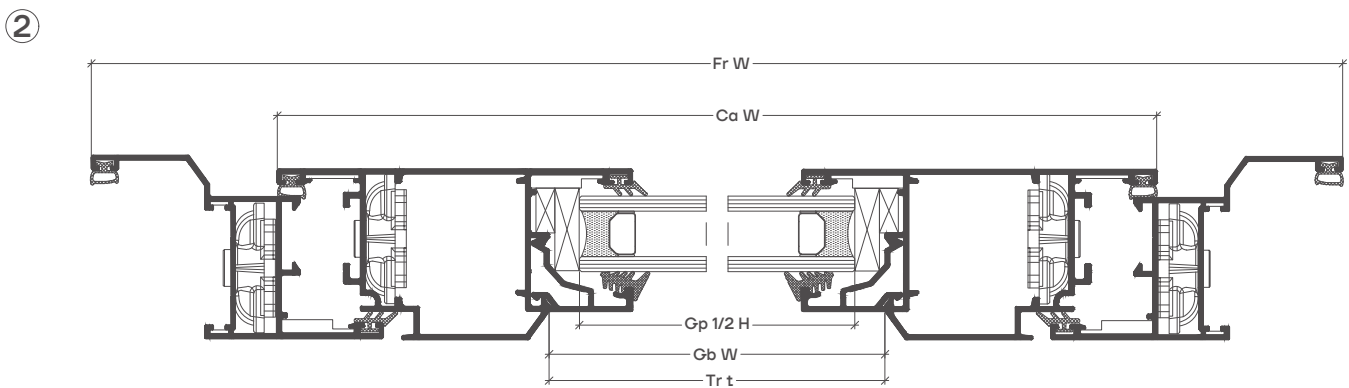
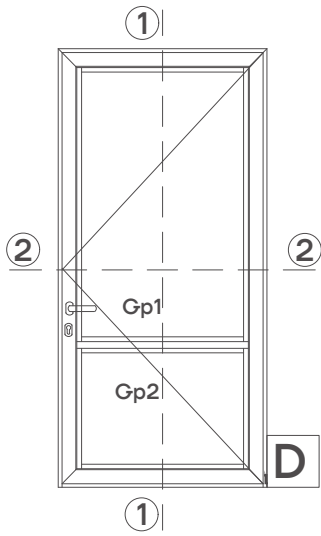

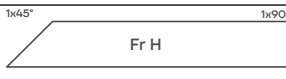
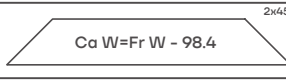
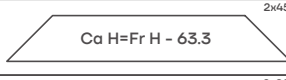
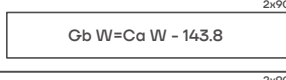
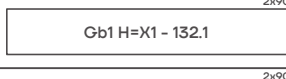
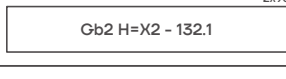

## outward opening door



outward opening door



Cuttings and quantities		
Code	Formula	Quantity
PLAWC.38.103 fame width	 $Fr\ W$	1 pcs
PLAWC.38.103 frame height	 $Fr\ H$	2 pcs mirror
PLAWC.45.203 casement width	 $Ca\ W=Fr\ W - 98.4$	2 pcs
PLAWC.45.203 casement height	 $Ca\ H=Fr\ H - 63.3$	2 pcs
PLAGC.07.601 glazing bead width	 $Gb\ W=Ca\ W - 143.8$	4 pcs
PLAGC.07.601 glazing bead height	 $Gb1\ H=X1 - 132.1$	2 pcs
PLAGC.07.601 glazing bead height	 $Gb2\ H=X2 - 132.1$	2 pcs
glass pane 1 W/H	$Gp1\ W=Ca\ W - 159.8$ $Gp1\ H=X1 - 103.9$	1 pcs
glass pane 2 W/H	$Gp2\ W=Ca\ W - 159.8$ $Gp2\ H=X2 - 103.9$	1 pcs
PLAWC.38.301 T - profile	$Tr\ t=Ca\ W - 143.8$	1 pcs
PLAAC.43.501 Ending profile	$Ep=Ca\ W - 10$	1 pcs

Accessory list			
Code	Accessory	Description	Quantity
PLA20.A200		external gasket	2Gb W+2Gb H
PLA20.A600		internal gasket	2Gb W+2Gb H
PLA20.A100		internal gasket	Ca W+2Ca H
PLA20.A700		alignment corner	6 pcs
PLA30.A100		alignment square with locking function	6 pcs
PLA30.A500		alignment corner	4 pcs
PLA30.A600		alignment corner	4 pcs
PLA10.A300		cap for ending profile	1 set
PLP20.S216		brush	2CaW-4
		glazing pad 1	8 pcs
		glazing pad 2	8 pcs

inward opening door

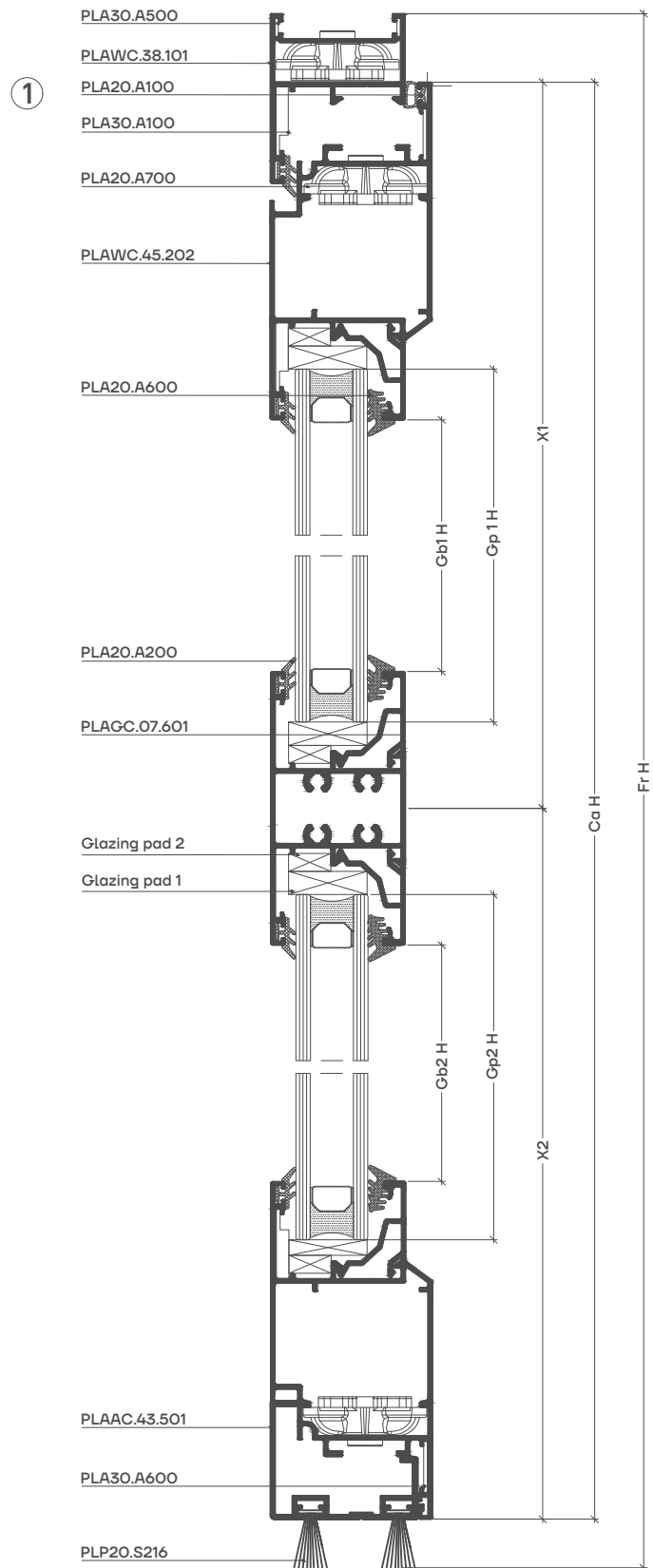
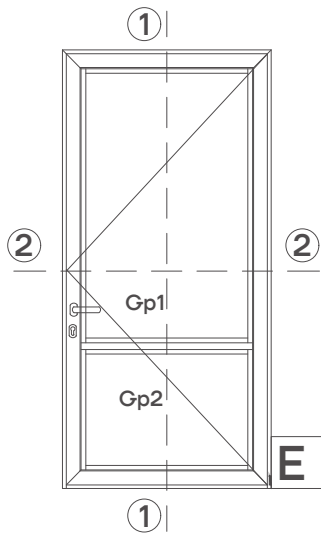



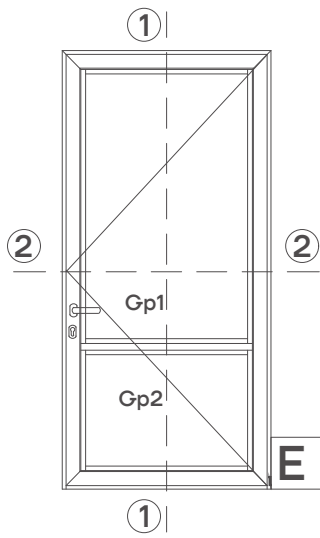



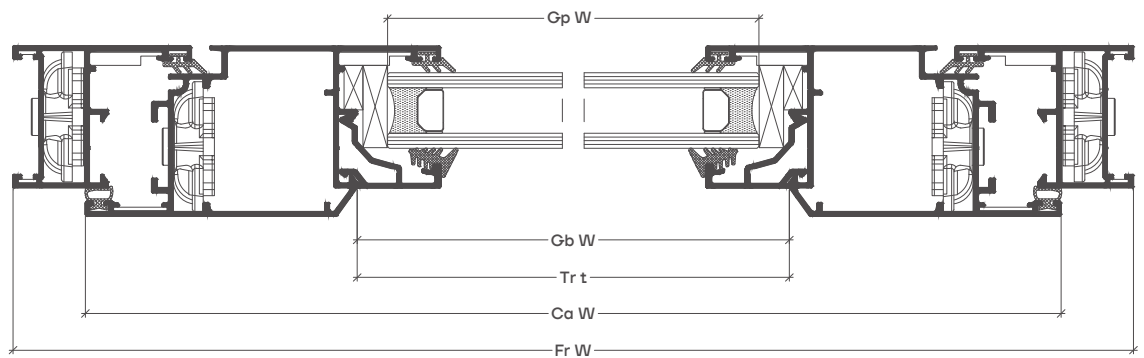



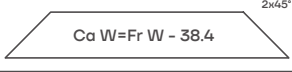
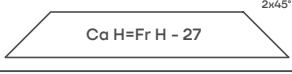
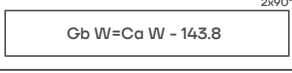
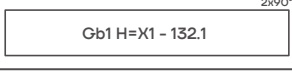
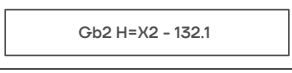
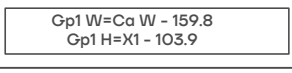
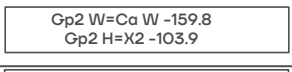
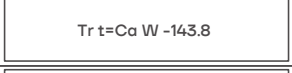
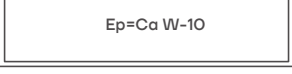



## inward opening door



②



Cuttings and quantities		
Code	Formula	Quantity
PLAWC.38.101 fame width	 Fr W	1 pcs
PLAWC.38.101 frame height	 Fr H	2 pcs mirror
PLAWC.45.202 casement width	 Ca W=Fr W - 38.4	2 pcs
PLAWC.45.202 casement height	 Ca H=Fr H - 27	2 pcs
PLAGC.07.601 glazing bead width	 Gb W=Ca W - 143.8	4 pcs
PLAGC.07.601 glazing bead height	 Gb1 H=X1 - 132.1	2 pcs
PLAGC.07.601 glazing bead height	 Gb2 H=X2 - 132.1	2 pcs
glass pane 1 W/H	 Gp1 W=Ca W - 159.8 Gp1 H=X1 - 103.9	1 pcs
glass pane 2 W/H	 Gp2 W=Ca W - 159.8 Gp2 H=X2 - 103.9	1 pcs
PLAWC.38.301 T - profile	 Tr t=Ca W - 143.8	1 pcs
PLAAC.43.501 Ending profile	 Ep=Ca W - 10	1 pcs

Accessory list			
Code	Accessory	Description	Quantity
PLA20.A200		external gasket	2Gb W+2Gb H
PLA20.A600		internal gasket	Gb W+2Gb H
PLA20.A100		internal gasket	Ca W+2Ca H
PLA20.A700		alignment corner	6 pcs
PLA30.A100		alignment square with locking function	6 pcs
PLA30.A500		aligment corner	4 pcs
PLA30.A600		aligment corner	4 pcs
PLA10.A300		cap for ending profile	1 set
PLP20.S216		brush	2CaW-4
		glazing pad 1	8 pcs
		glazing pad 2	8 pcs





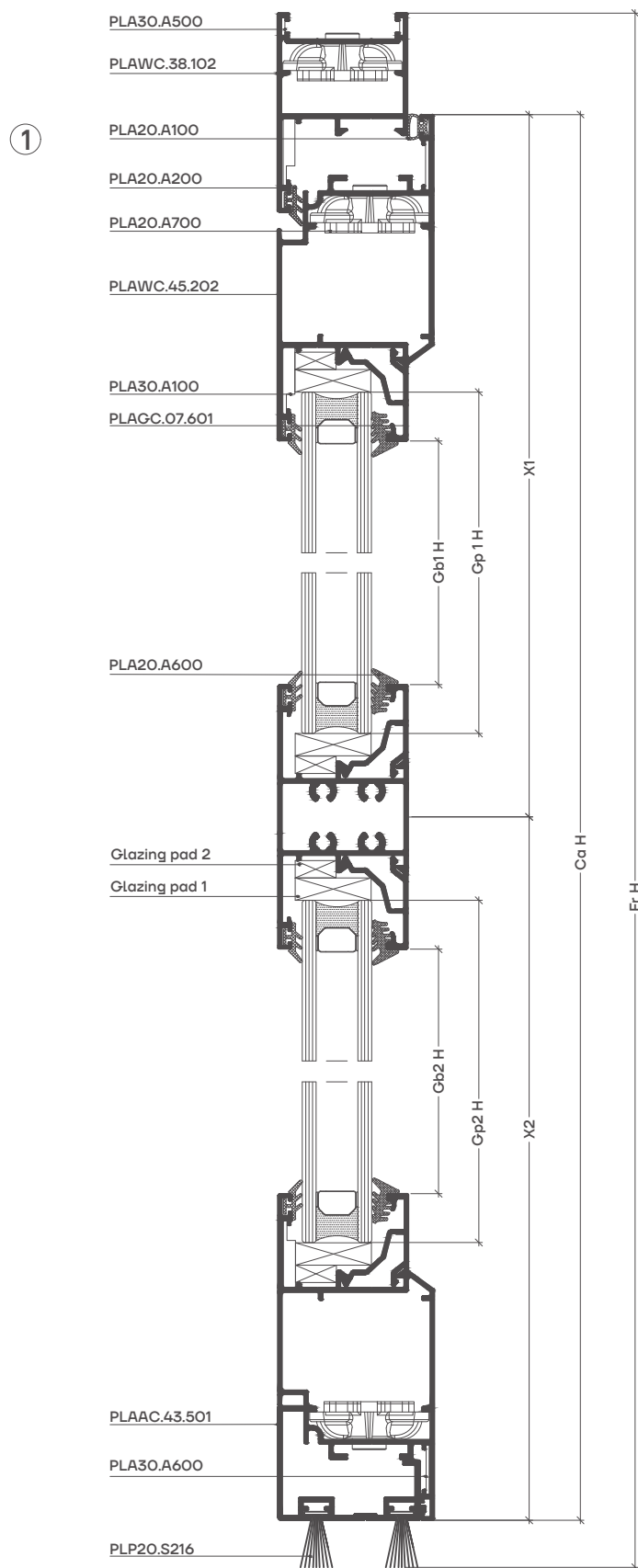
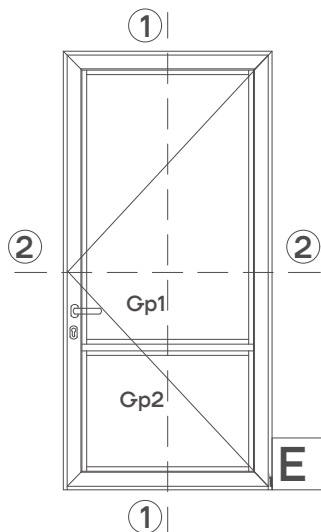



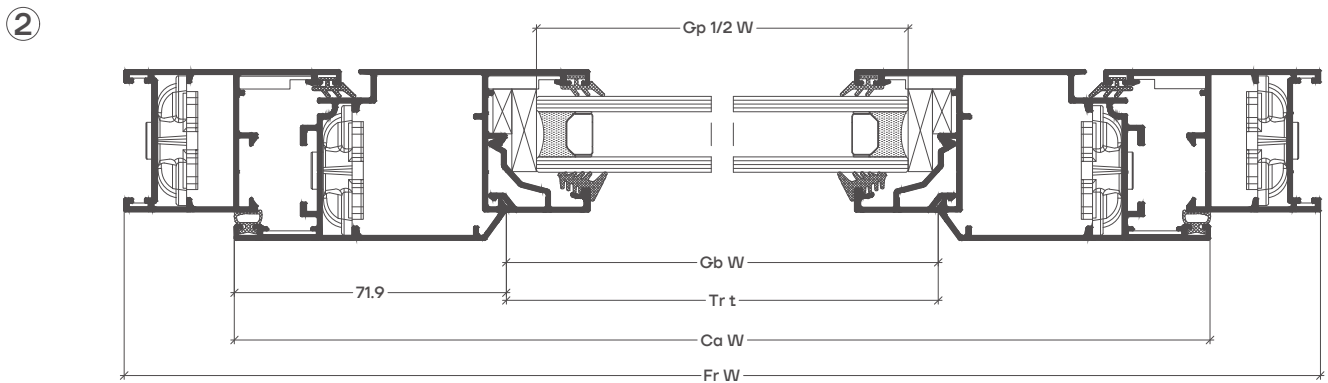
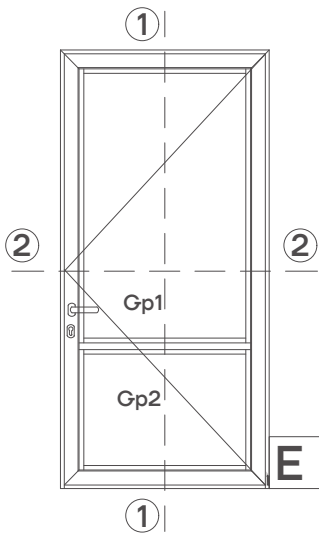



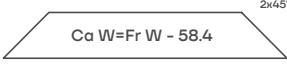
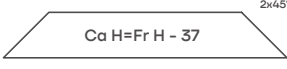
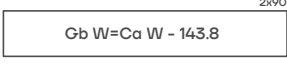
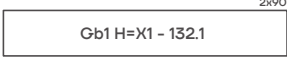
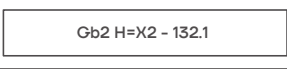
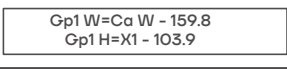
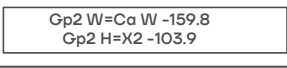

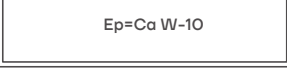



## inward opening door



inward opening door



Cuttings and quantities		
Code	Formula	Quantity
PLAWC.38.102 fame width	 Fr W	1 pcs
PLAWC.38.102 frame height	 Fr H	2 pcs mirror
PLAWC.45.202 casement width	 Ca W=Fr W - 58.4	2 pcs
PLAWC.45.202 casement height	 Ca H=Fr H - 37	2 pcs
PLAGC.07.601 glazing bead width	 Gb W=Ca W - 143.8	4 pcs
PLAGC.07.601 glazing bead height	 Gb1 H=X1 - 132.1	2 pcs
PLAGC.07.601 glazing bead height	 Gb2 H=X2 - 132.1	2 pcs
glass pane 1 W/H	 Gp1 W=Ca W - 159.8 Gp1 H=X1 - 103.9	1 pcs
glass pane 2 W/H	 Gp2 W=Ca W - 159.8 Gp2 H=X2 - 103.9	1 pcs
PLAWC.38.301 T - profile	 Tr t=Ca W - 143.8	1 pcs
PLAAC.43.501 Ending profile	 Ep=Ca W - 10	1 pcs



Accessory list			
Code	Accessory	Description	Quantity
PLA20.A200		external gasket	2Gb W+2Gb H
PLA20.A600		internal gasket	2Gb W+2Gb H
PLA20.A100		internal gasket	Ca W+2Ca H
PLA20.A700		alignment corner	6 pcs
PLA30.A100		alignment square with locking function	6 pcs
PLA30.A500		aligment corner	4 pcs
PLA30.A600		aligment corner	4 pcs
PLA10.A300		cap for ending profile	1 set
PLP20.S216		brush	2 CaW-4
		glazing pad 1	8 pcs
		glazing pad 2	8 pcs

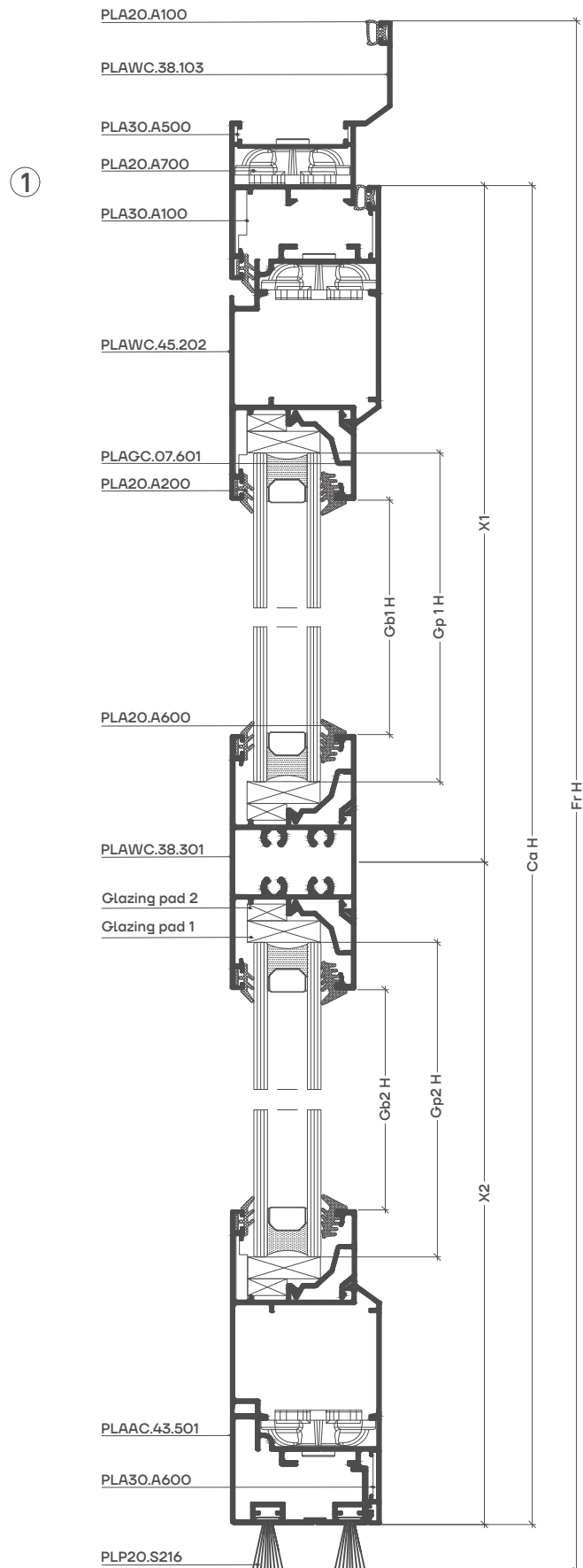
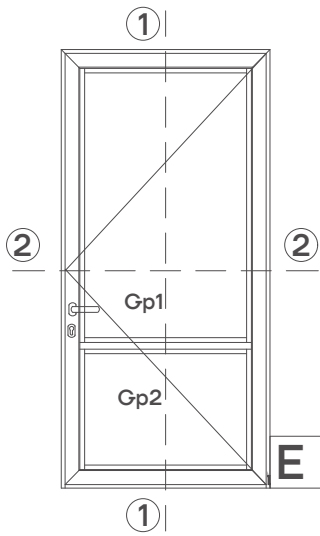



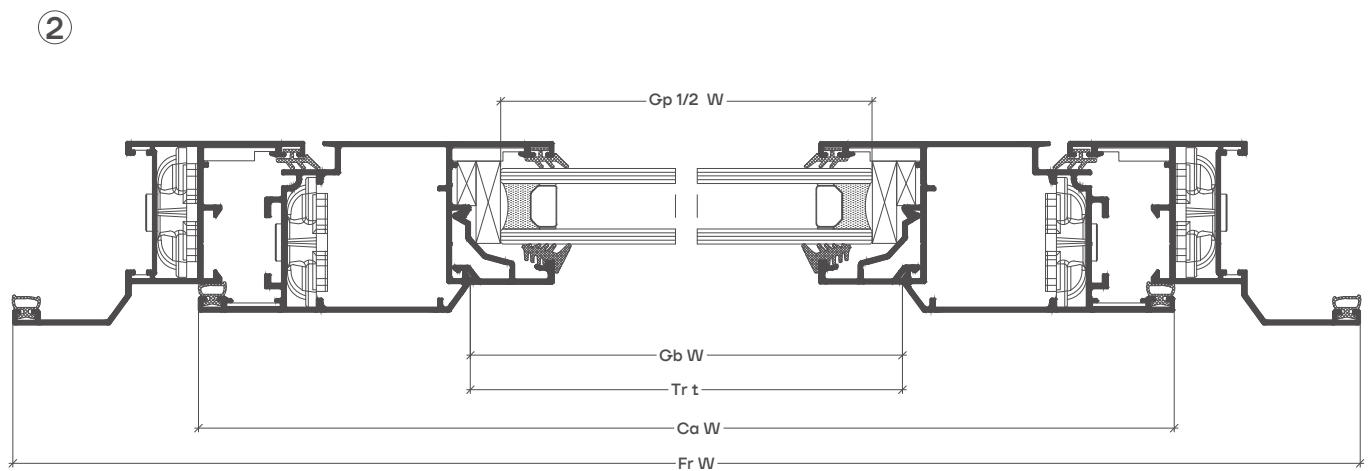
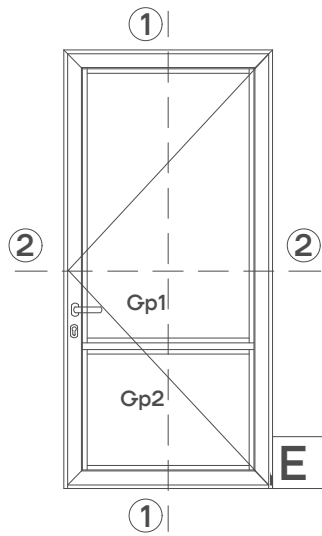



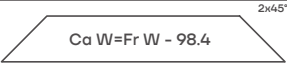
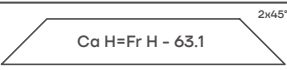
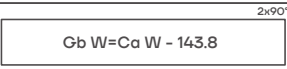
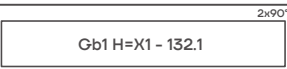
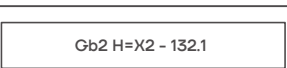

**inward opening door**



## inward opening door



Cuttings and quantities		
Code	Formula	Quantity
PLAWC.38.103 fame width	 $Fr\ W$	1 pcs
PLAWC.38.103 frame height	 $Fr\ H$	2 pcs mirror
PLAWC.45.202 casement width	 $Ca\ W=Fr\ W - 98.4$	2 pcs
PLAWC.45.202 casement height	 $Ca\ H=Fr\ H - 63.1$	2 pcs
PLAGC.07.601 glazing bead width	 $Gb\ W=Ca\ W - 143.8$	4 pcs
PLAGC.07.601 glazing bead height	 $Gb1\ H=X1 - 132.1$	2 pcs
PLAGC.07.601 glazing bead height	 $Gb2\ H=X2 - 132.1$	2 pcs
glass pane 1 W/H	$Gp1\ W=Ca\ W - 159.8$ $Gp1\ H=X1 - 103.9$	1 pcs
glass pane 2 W/H	$Gp2\ W=Ca\ W - 159.8$ $Gp2\ H=X2 - 103.9$	1 pcs
PLAWC.38.301 T - profile	$Tr\ t=Ca\ W - 143.8$	1 pcs
PLAAC.43.501 Ending profile	$Ep=Ca\ W - 10$	1 pcs

Accessory list			
Code	Accessory	Description	Quantity
PLA20.A200		external gasket	$2Gb\ W+2Gb\ H$
PLA20.A600		internal gasket	$2Gb\ W+2Gb\ H$
PLA20.A100		internal gasket	$Ca\ W+2Ca\ H$
PLA20.A700		alignment corner	6 pcs
PLA30.A100		alignment square with locking function	6 pcs
PLA30.A500		alignment corner	4 pcs
PLA30.A600		alignment corner	4 pcs
PLA10.A300		cap for ending profile	1 set
PLP20.S216		brush	$2CaW-4$
		glazing pad 1	8 pcs
		glazing pad 2	8 pcs

## outward opening door

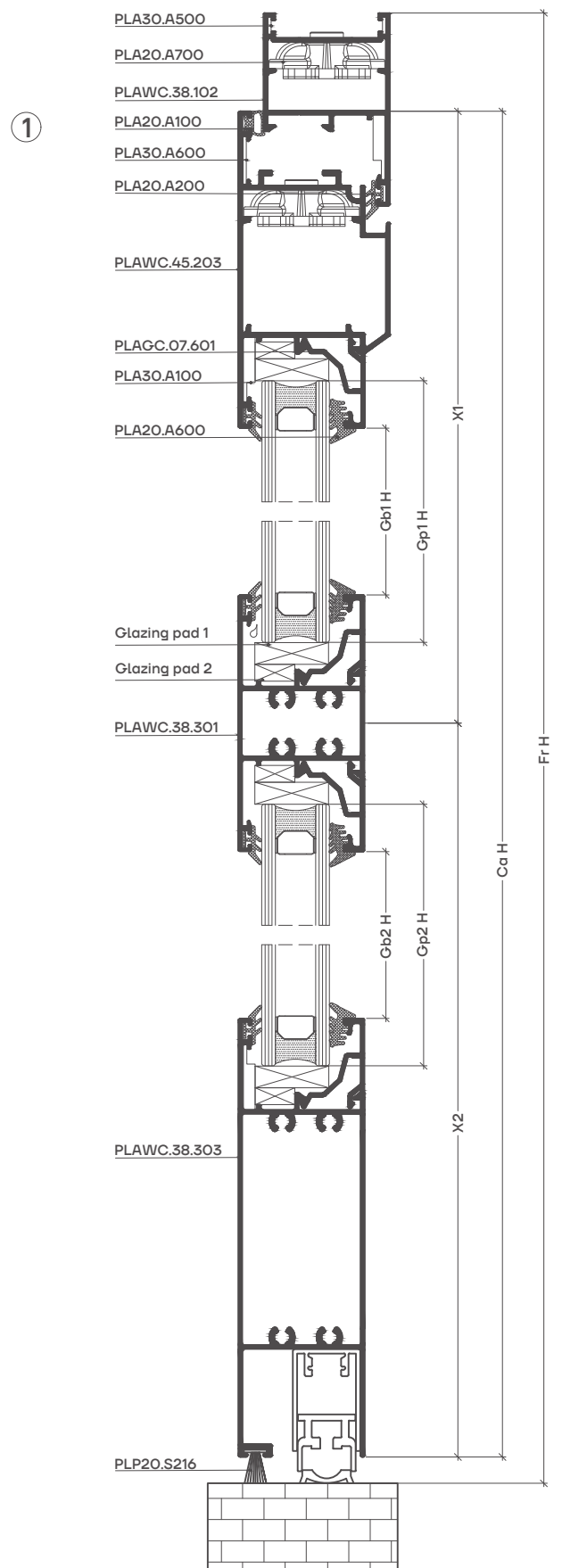
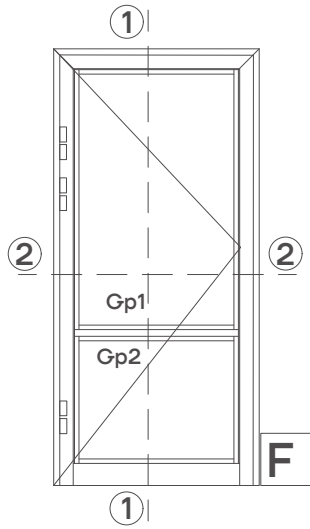



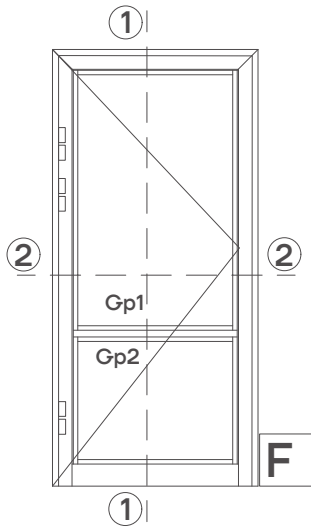

outward opening door

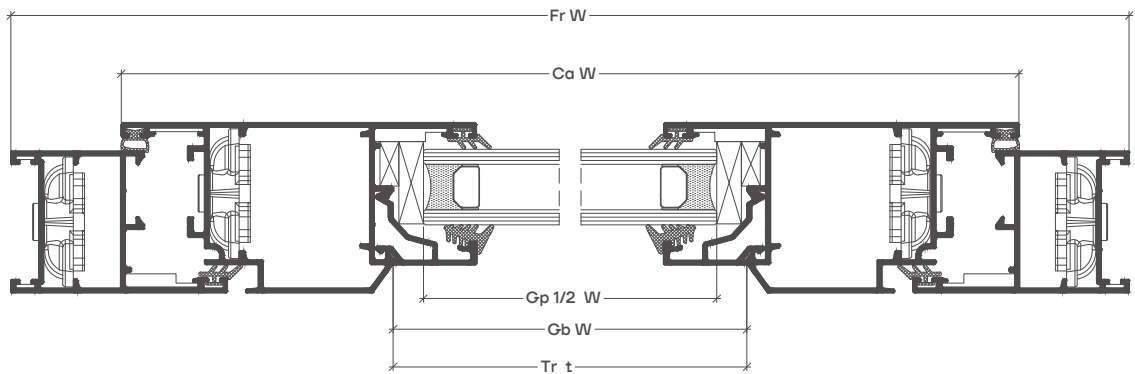





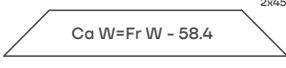
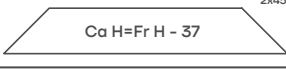
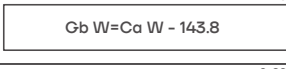
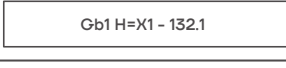
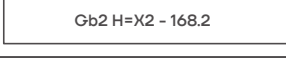
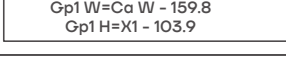
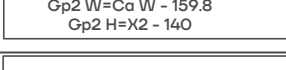
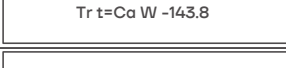





②





Cuttings and quantities		
Code	Formula	Quantity
PLAWC.38.102 fame width	 Fr W	1 pcs
PLAWC.38.102 frame height	 Fr H	2 pcs mirror
PLAWC.45.202 casement width	 Ca W=Fr W - 58.4	2 pcs
PLAWC.45.202 casement height	 Ca H=Fr H - 37	2 pcs
PLAGC.07.601 glazing bead width	 Gb W=Ca W - 143.8	2 pcs
PLAGC.07.601 glazing bead height	 Gb1 H=X1 - 132.1	2 pcs
PLAGC.07.601 glazing bead height	 Gb2 H=X2 - 168.2	2 pcs
glass pane 1 W/H	 Gp1 W=Ca W - 159.8 Gp1 H=X1 - 103.9	1 pcs
glass pane 2 W/H	 Gp2 W=Ca W - 159.8 Gp2 H=X2 - 140	1 pcs
PLAWC.38.301 T - profile	 Tr t=Ca W - 143.8	1 pcs
PLAWC.38.303 Kick-plate	 Kp =Tr t	1 pcs

Accessory list			
Code	Accessory	Description	Quantity
PLA20.A200		external gasket	2Gb W+2Gb H
PLA20.A600		internal gasket	2Gb W+2Gb H
PLA20.A100		internal gasket	Ca W+2Ca H
PLA20.A700		alignment corner	4 pcs
PLA30.A100		alignment square with locking function	6 pcs
PLA30.A500		aligment corner	4 pcs
PLA30.A600		aligment corner	2 pcs
PLP20.S216		brush	brush=Kp
		glazing pad 1	8 pcs
		glazing pad 2	8 pcs

inward opening door

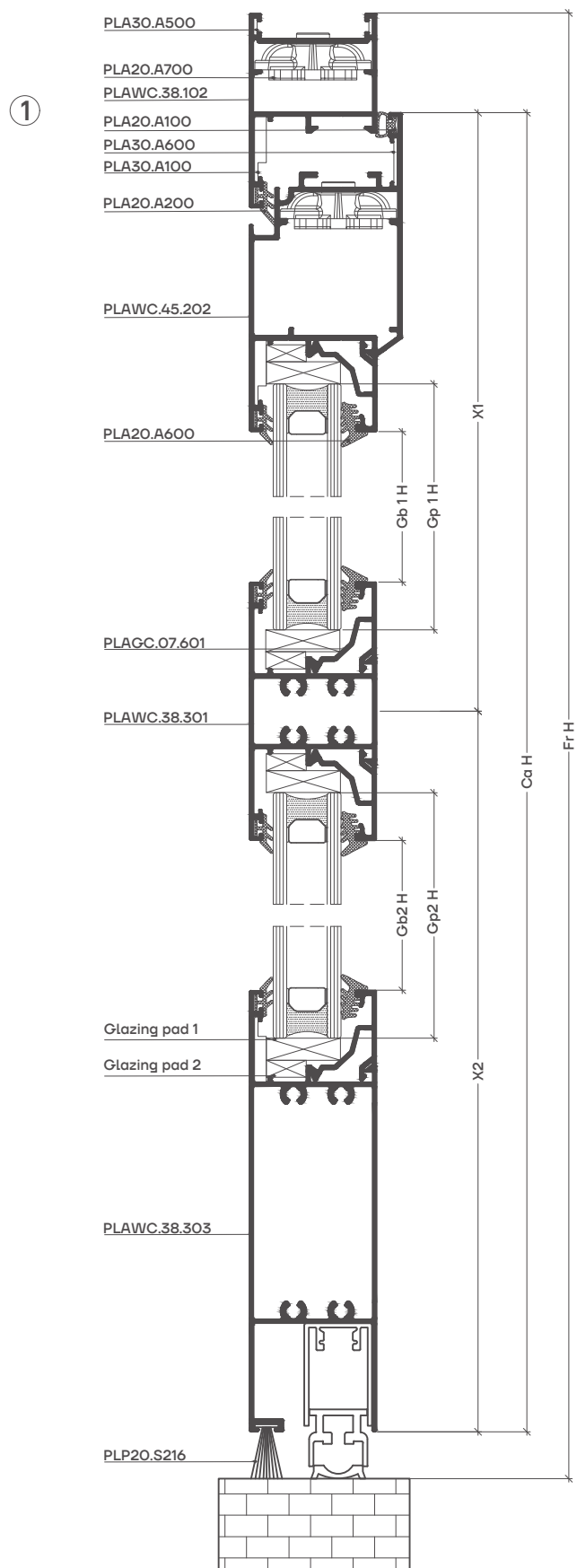
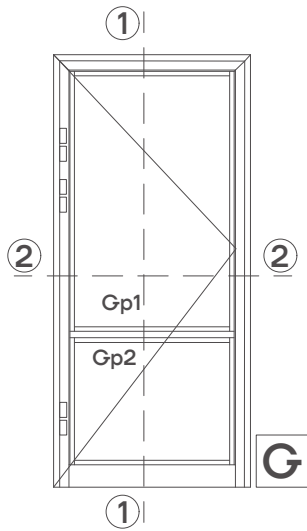



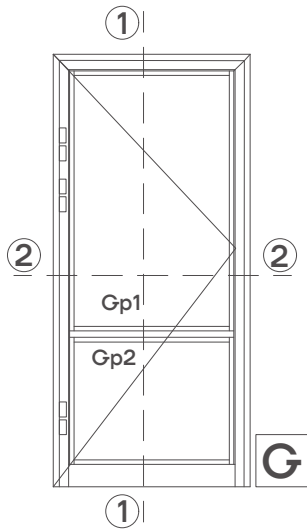



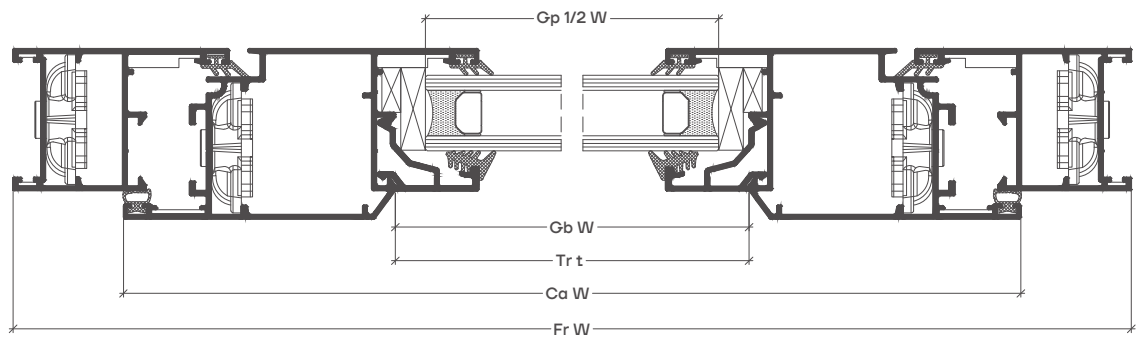

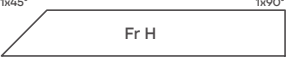
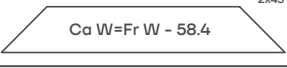
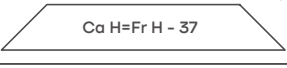
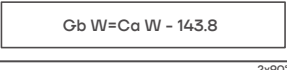
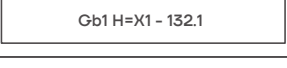
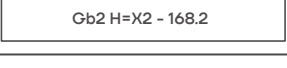
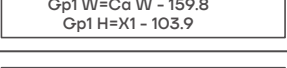
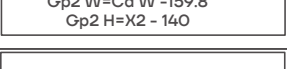
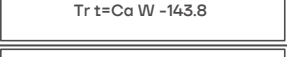
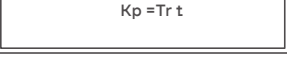

## inward opening door



2



Cuttings and quantities		
Code	Formula	Quantity
PLAWC.38.102 fame width	 Fr W	1 pcs
PLAWC.38.102 frame height	 Fr H	2 pcs mirror
PLAWC.45.202 casement width	 Ca W=Fr W - 58.4	2 pcs
PLAWC.45.202 casement height	 Ca H=Fr H - 37	2 pcs
PLAGC.07.601 glazing bead width	 Gb W=Ca W - 143.8	2 pcs
PLAGC.07.601 glazing bead height	 Gb1 H=X1 - 132.1	2 pcs
PLAGC.07.601 glazing bead height	 Gb2 H=X2 - 168.2	2 pcs
glass pane 1 W/H	 Gp1 W=Ca W - 159.8 Gp1 H=X1 - 103.9	1 pcs
glass pane 2 W/H	 Gp2 W=Ca W - 159.8 Gp2 H=X2 - 140	1 pcs
PLAWC.38.301 T - profile	 Tr t=Ca W - 143.8	1 pcs
PLAWC.38.303 Kick-plate	 Kp =Tr t	1 pcs



Accessory list			
Code	Accessory	Description	Quantity
PLA20.A200		external gasket	2Gb W+2Gb H
PLA20.A600		internal gasket	2Gb W+2Gb H
PLA20.A100		internal gasket	Ca W+2Ca H
PLA20.A700		alignment corner	4 pcs
PLA30.A100		alignment square with locking function	6 pcs
PLA30.A500		aligment corner	4 pcs
PLA30.A600		aligment corner	4 pcs
PLP20.S216		brush	brush=Kp
		glazing pad 1	8 pcs
		glazing pad 2	8 pcs

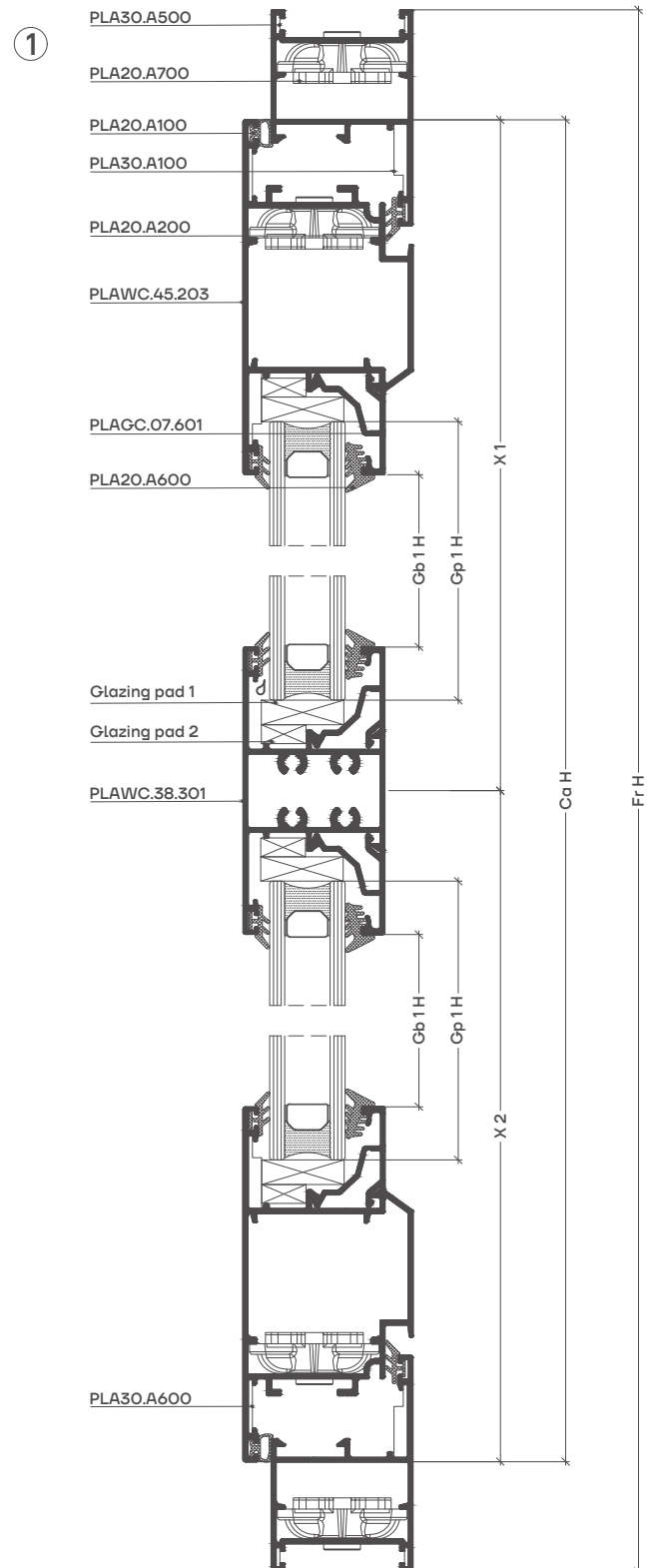
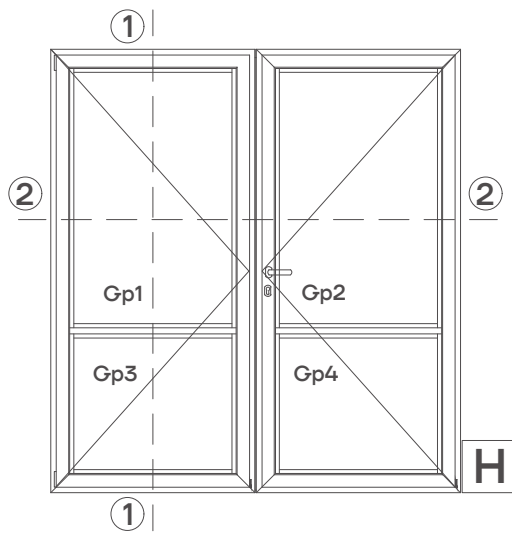



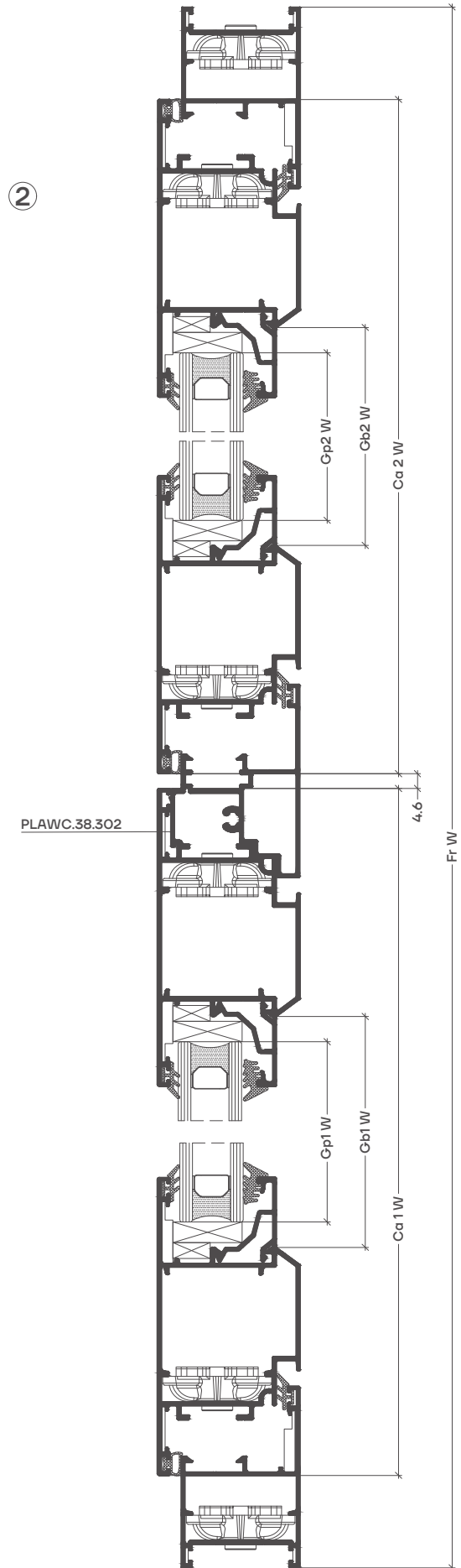
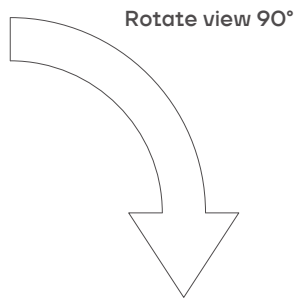
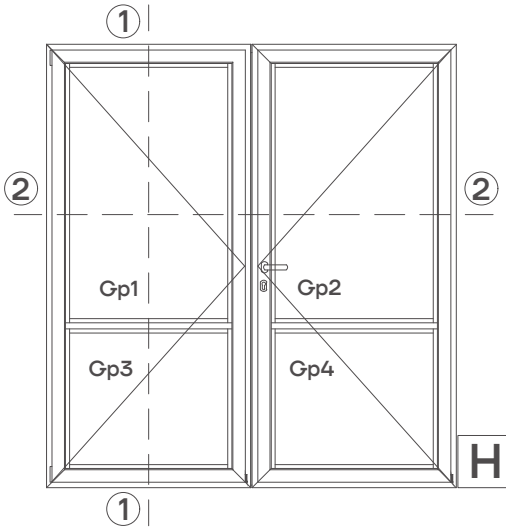

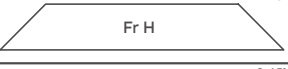
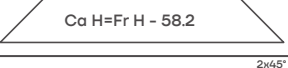
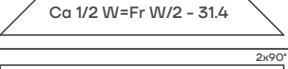
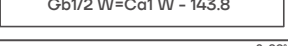
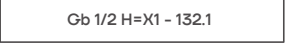
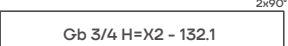
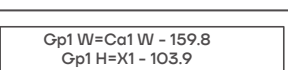
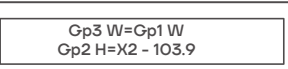

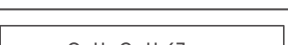

## outward opening door



outward opening door



Cuttings and quantities		
Code	Formula	Quantity
PLAWC.38.102 fame width	 $Fr W$	2 pcs
PLAWC.38.102 frame height	 $Fr H$	2 pcs
PLAWC.45.202 casement height	 $Ca H = Fr H - 58.2$	4 pcs
PLAWC.45.202 casement width	 $Ca 1/2 W = Fr W/2 - 31.4$	4 pcs
PLAGC.07.601 glazing bead width	 $Gb 1/2 W = Ca 1 W - 143.8$	8 pcs
PLAGC.07.601 glazing bead height	 $Gb 1/2 H = X1 - 132.1$	4 pcs
PLAGC.07.601 glazing bead height	 $Gb 3/4 H = X2 - 132.1$	4 pcs
glass pane 1/2 W/H	 $Gp1 W = Ca 1 W - 159.8$ $Gp1 H = X1 - 103.9$	2 pcs
glass pane 3/4 W/H	 $Gp3 W = Gp1 W$ $Gp2 H = X2 - 103.9$	2 pcs
PLAWC.38.301 T - profile	 $Tr t 1/2 = Ca 1 W - 143.8$	2 pcs
PLAWC.38.302 Overhung	 $Ov H = Ca H - 67$	1 pcs



Accessory list			
Code	Accessory	Description	Quantity
PLA20.A200		external gasket	2Gb W+2Gb H
PLA20.A600		internal gasket	2Gb W+2Gb H
PLA20.A100		internal gasket	2Ca1 W+2Ca H 2Ca2 W+2Ca H
PLA20.A700		alignment corner	12 pcs
PLA30.A100		alignment square with locking function	12 pcs
PLA30.A500		alignment corner	8 pcs
PLA30.A600		alignment corner	8 pcs
PLA10.A100		cap for overhung	1 set
PLA30.A300		alignment corner	4 pcs
		glazing pad 1	16 pcs
		glazing pad 2	16 pcs

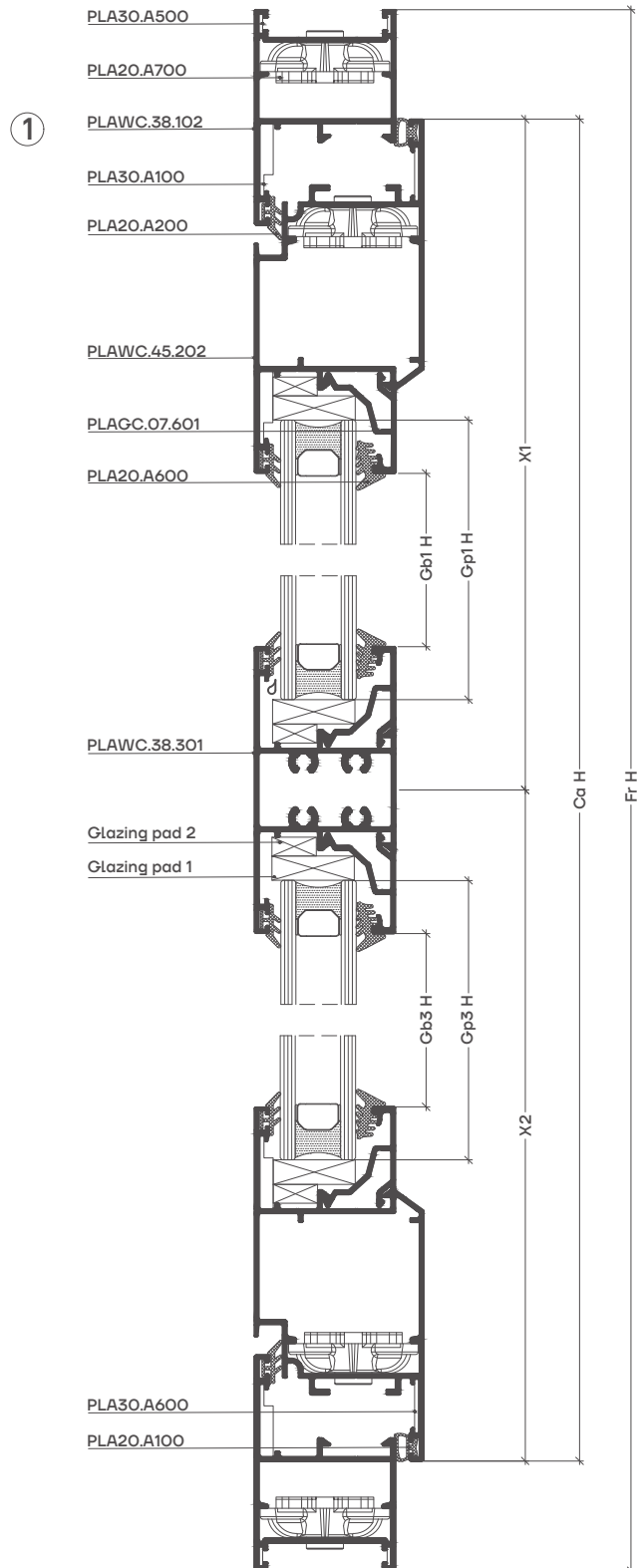
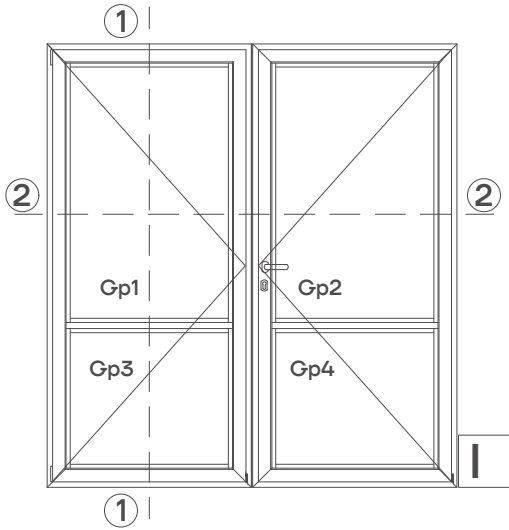



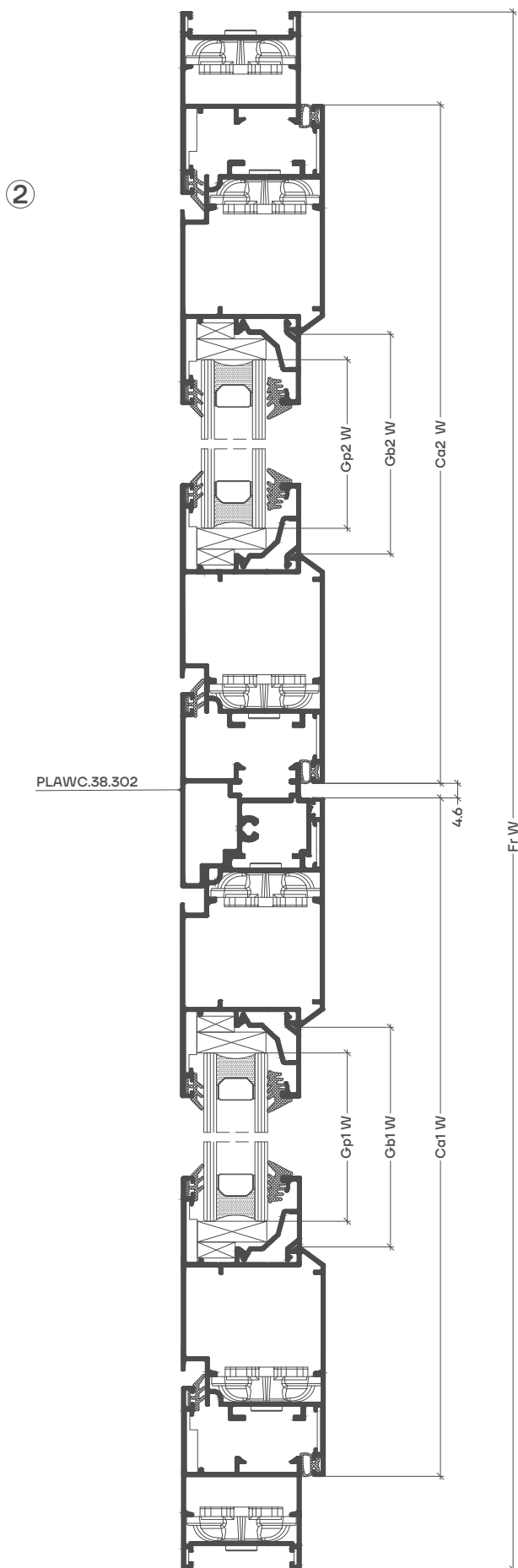
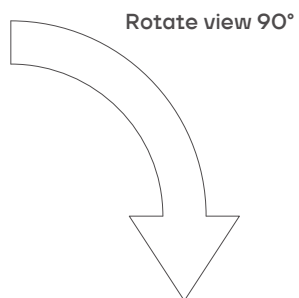
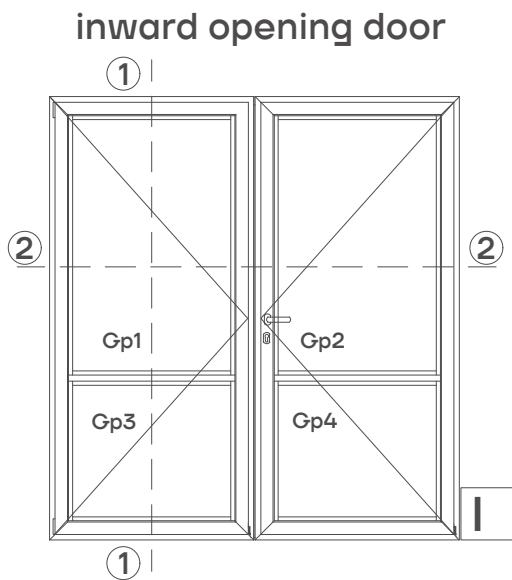



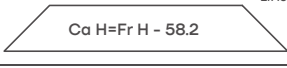
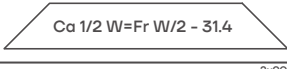
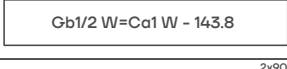
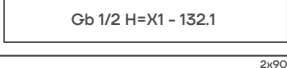
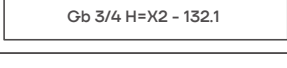
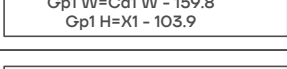
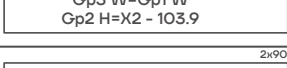
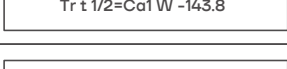
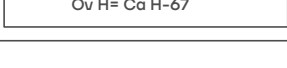

inward opening door







Cuttings and quantities		
Code	Formula	Quantity
PLAWC.38.102 fame width		2 pcs
PLAWC.38.102 frame height		2 pcs
PLAWC.45.203 casement height		4 pcs
PLAWC.45.203 casement width		4 pcs
PLAGC.07.601 glazing bead width		8 pcs
PLAGC.07.601 glazing bead height		4 pcs
PLAGC.07.601 glazing bead height		4 pcs
glass pane 1/2 W/H		2 pcs
glass pane 3/4 W/H		2 pcs
PLAWC.38.301 T - profile		2 pcs
PLAWC.38.302 Overhung		1 pcs

Accessory list			
Code	Accessory	Description	Quantity
PLA20.A200		external gasket	2Gb W+2Gb H
PLA20.A600		internal gasket	2Gb W+2Gb H
PLA20.A100		internal gasket	2Ca1 W+2Ca H 2Ca2 W+2Ca H
PLA20.A700		alignment corner	12 pcs
PLA30.A100		alignment square with locking function	12 pcs
PLA30.A500		aligment corner	8 pcs
PLA30.A600		aligment corner	8 pcs
PLA10.A100		cap for overhung	1 set
PLA30.A300		alignment corner	4 pcs
		glazing pad 1	16 pcs
		glazing pad 1	16 pcs

## inward opening door

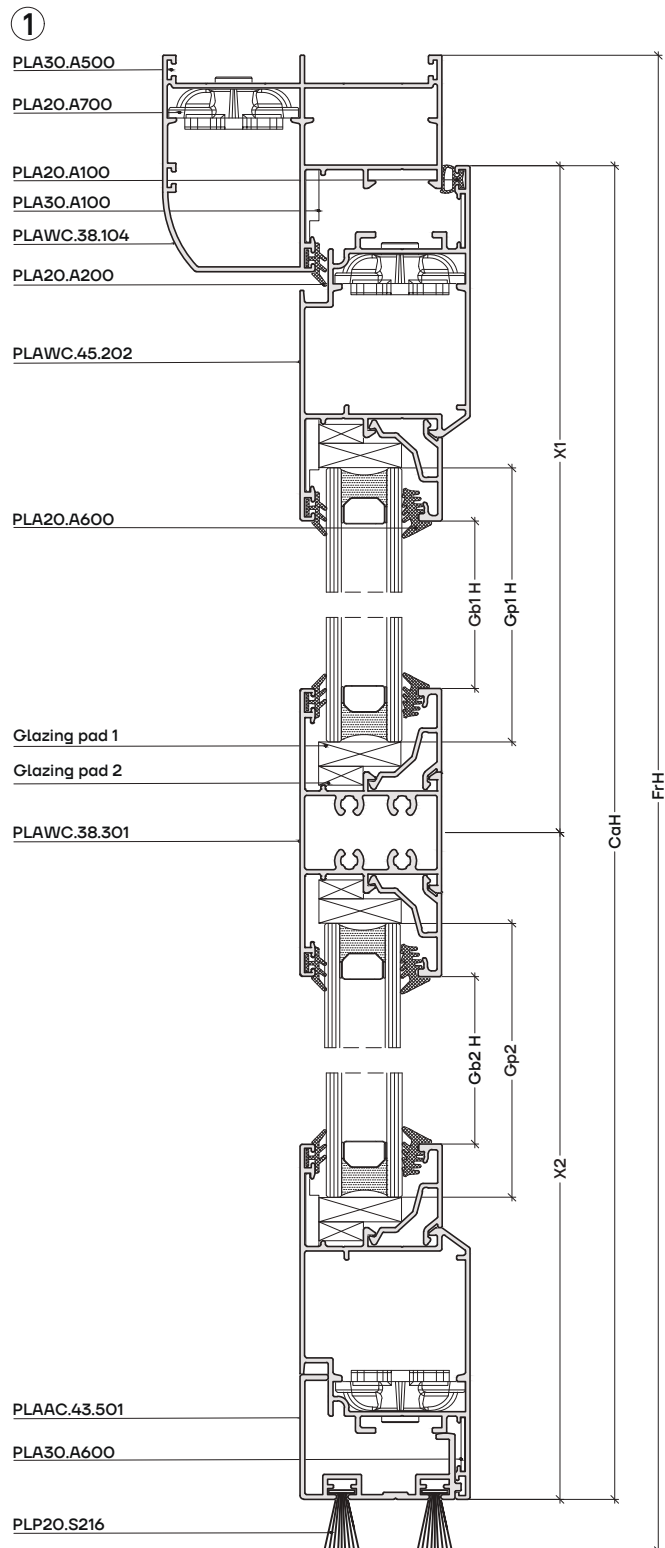
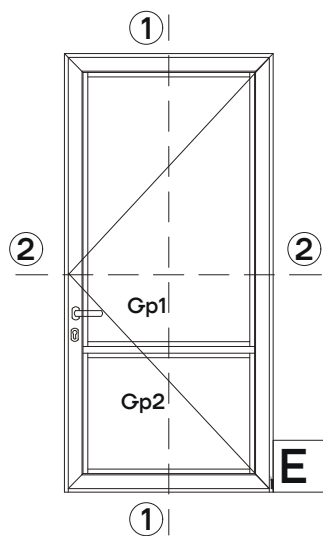



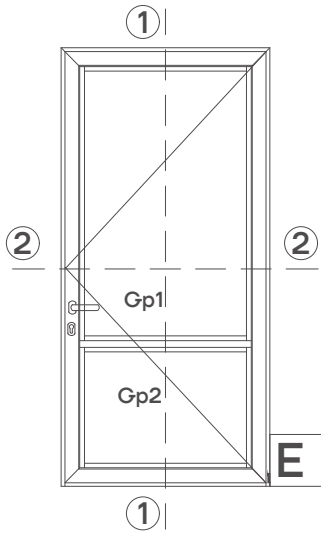



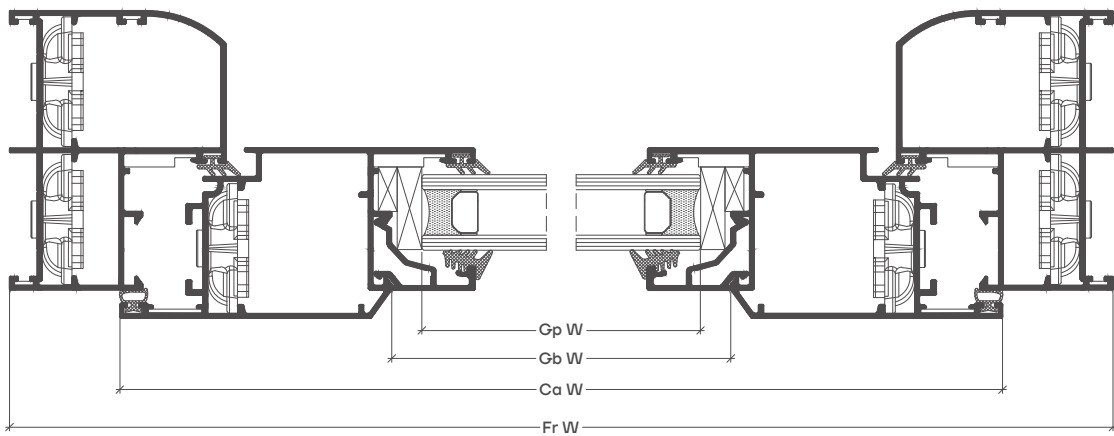



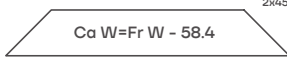
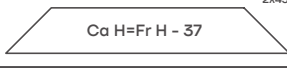
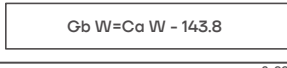
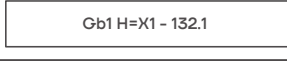
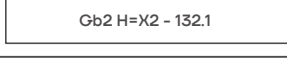
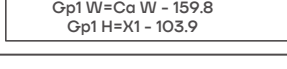
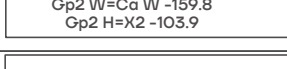
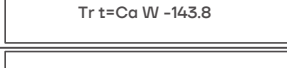
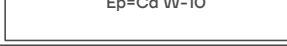



**inward opening door**



②



Cuttings and quantities		
Code	Formula	Quantity
PLAWC.38.103 fame width	 Fr W	1 pcs
PLAWC.38.103 frame height	 Fr H	2 pcs mirror
PLAWC.45.202 casement width	 Ca W=Fr W - 58.4	2 pcs
PLAWC.45.202 casement height	 Ca H=Fr H - 37	2 pcs
PLAGC.07.601 glazing bead width	 Gb W=Ca W - 143.8	4 pcs
PLAGC.07.601 glazing bead height	 Gb1 H=X1 - 132.1	2 pcs
PLAGC.07.601 glazing bead height	 Gb2 H=X2 - 132.1	2 pcs
glass pane 1 W/H	 Gp1 W=Ca W - 159.8 Gp1 H=X1 - 103.9	1 pcs
glass pane 2 W/H	 Gp2 W=Ca W - 159.8 Gp2 H=X2 - 103.9	1 pcs
PLAWC.38.301 T - profile	 Tr t=Ca W - 143.8	1 pcs
PLAAC.43.501 Ending profile	 Ep=Ca W-10	1 pcs

Accessory list			
Code	Accessory	Description	Quantity
PLA20.A200		external gasket	2Gb W+2Gb H
PLA20.A600		internal gasket	2Gb W+2Gb H
PLA20.A100		internal gasket	Ca W+2Ca H
PLA20.A700		alignment corner	8 pcs
PLA30.A100		alignment square with locking function	6 pcs
PLA30.A500		aligment corner	6 pcs
PLA30.A600		aligment corner	4 pcs
PLA10.A300		cap for ending profile	1 set
PLP20.S216		brush	2CaW-4
		glazing pad 1	8 pcs
		glazing pad 2	8 pcs

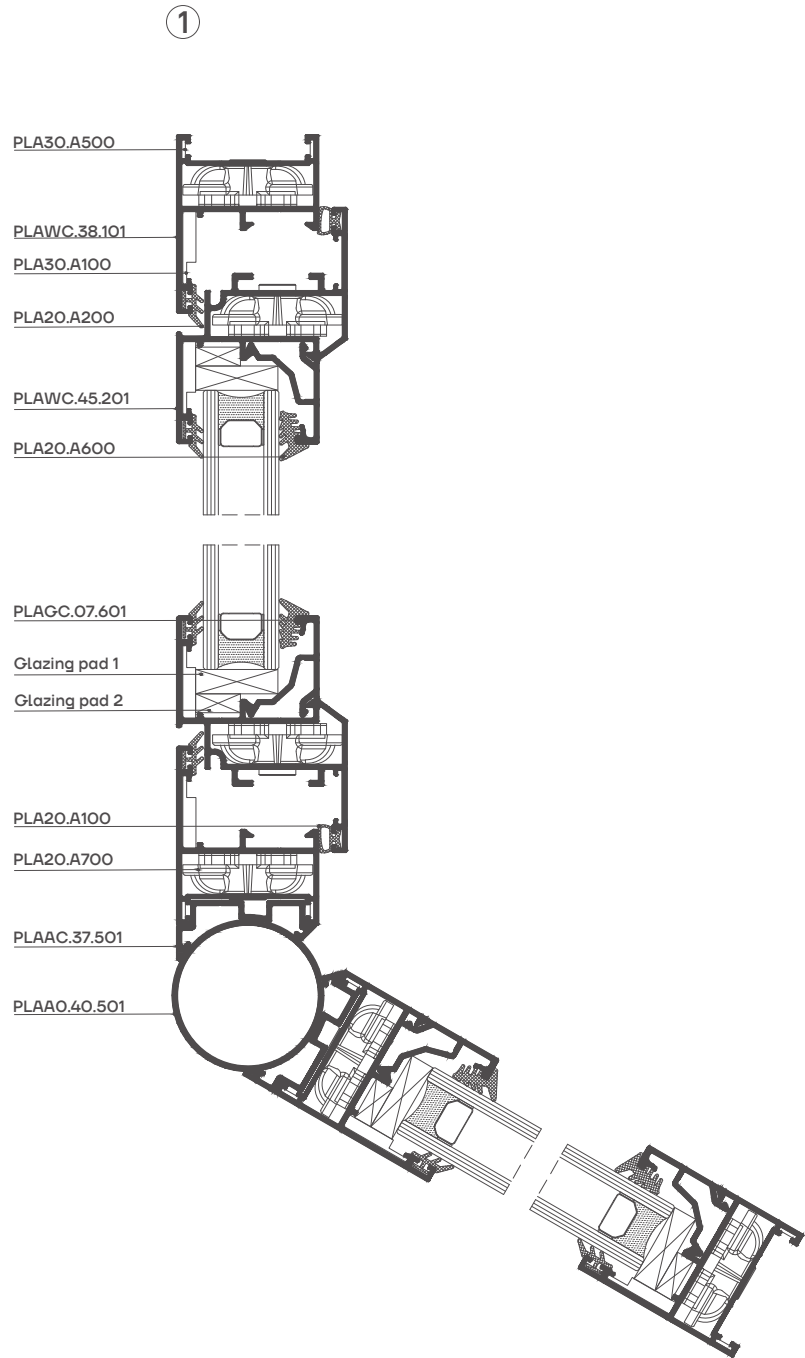
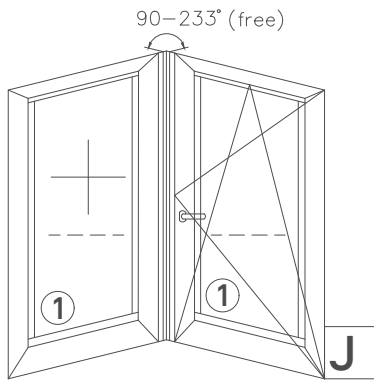

The background is a solid teal color. It features several abstract, overlapping geometric shapes in a lighter teal and a yellow-gold color. These shapes consist of straight lines and rounded corners, creating a modern, architectural feel. One prominent shape is a large, rounded rectangle with a yellow-gold outline, partially overlapping other shapes. Another shape is a trapezoid-like form with a yellow-gold outline, positioned below the first one. The overall composition is clean and minimalist.

# Glazing options







# Glass load support scheme

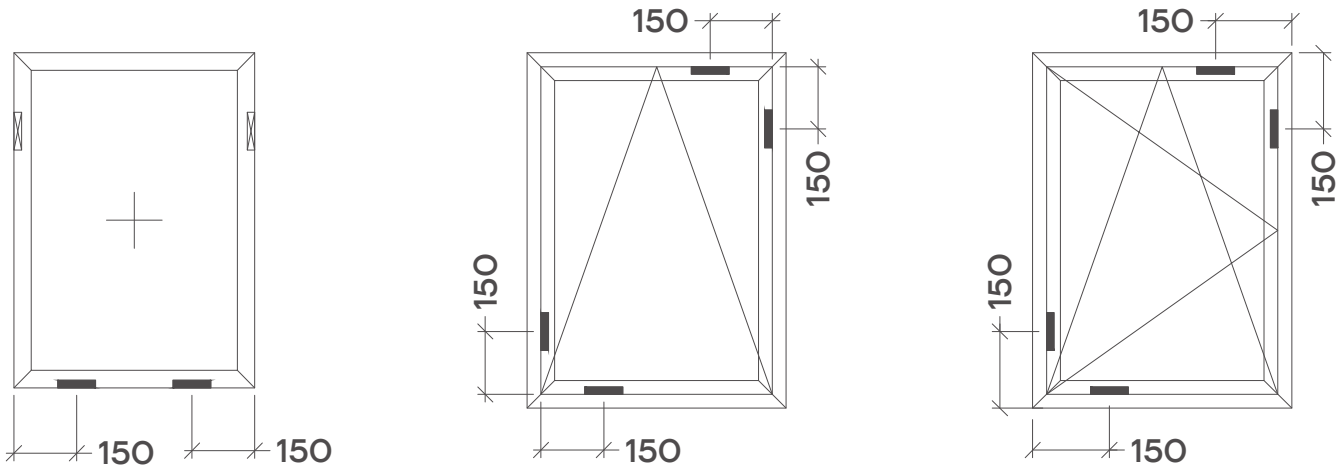

■ load glazing shim - 150mm from glazing edge!

⊠ filling shim do not have exactly defined position

## Anchor position scheme

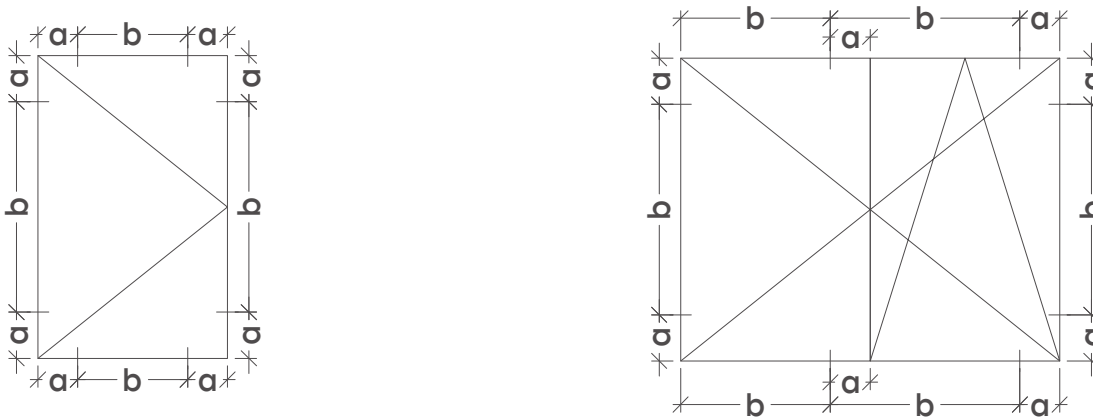

$a = 150 \div 200 \text{ mm}$   
 $b \leq 800 \text{ mm}$

The background is a solid teal color. It features several thin, yellow lines that create a geometric pattern. One line runs diagonally from the top right towards the bottom left. Another line runs horizontally across the middle. A third line runs diagonally from the bottom left towards the top right. These lines intersect to form various shapes, including triangles and trapezoids. The word 'Machining' is centered in the upper right area of the page.

# Machining



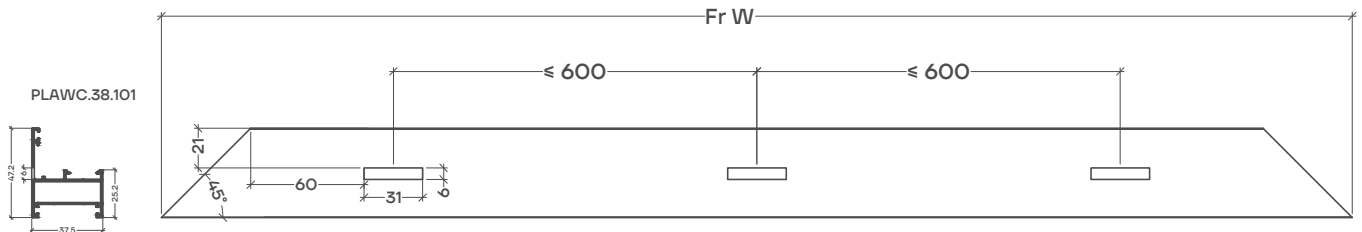

## Additional machining of profiles after cutting Frame PLAWC.38.101- machining for drainage

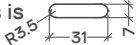

**Note:**

This machining is valid for all the frame profiles of the system

For CNC machine drainage slots is  for punching machine is 

## Additional machining of profiles after cutting Frame PLAWC.38.102- machining for drainage

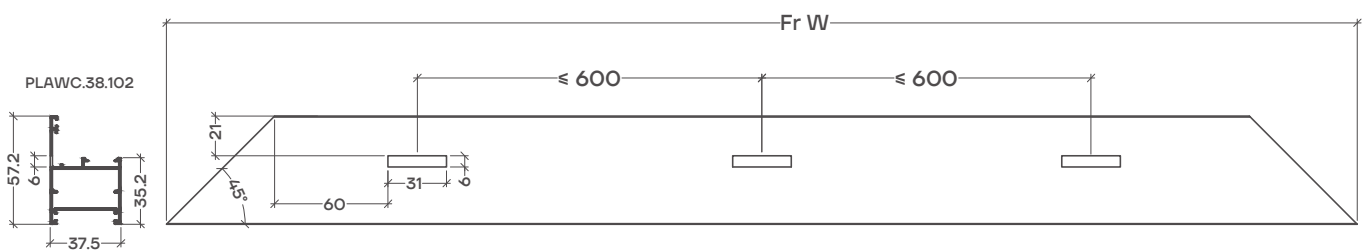

**Note:**

This machining is valid for all the frame profiles of the system

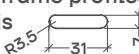
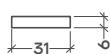
For CNC machine drainage slots is  for punching machine is 

**Additional machining of profiles after cutting  
Frame PLAWC.38.103- machining for drainage**

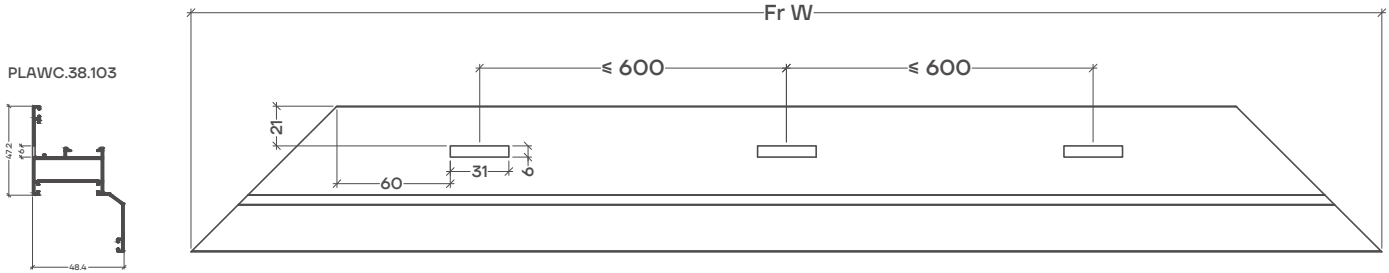

**Note:**

This machining is valid for all the frame profiles of the system

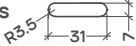
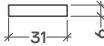
For CNC machine drainage slots is  for punching machine is 

**Additional machining of profiles after cutting  
Frame PLAWC.38.104- machining for drainage**

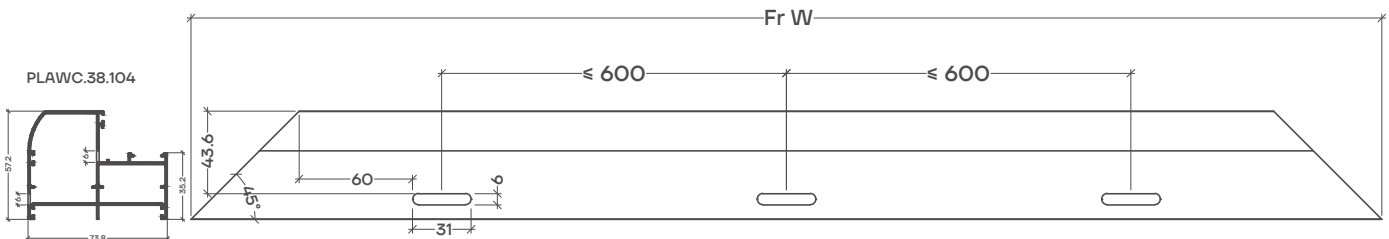
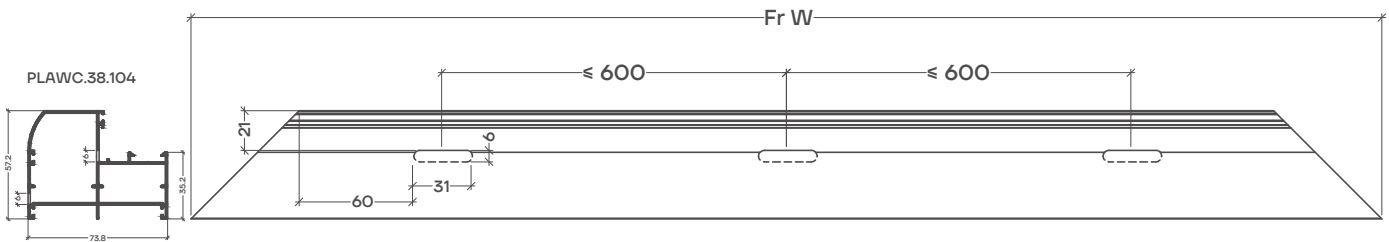

**Note:**

This machining is valid for all the frame profiles of the system

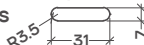
For CNC machine drainage slots is 

## Additional machining of profiles after cutting Casement PLAWC.45.201- machining for drainage

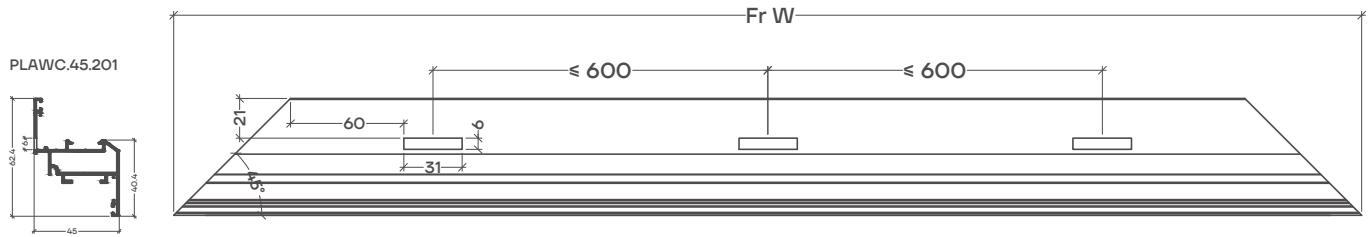

**Note:**

This machining is valid for all the casement profiles of the system

For CNC machine drainage slots is

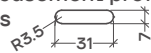

for punching machine is

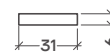

## Additional machining of profiles after cutting Kick-plate PLAWC.38.303 - machining for drainage

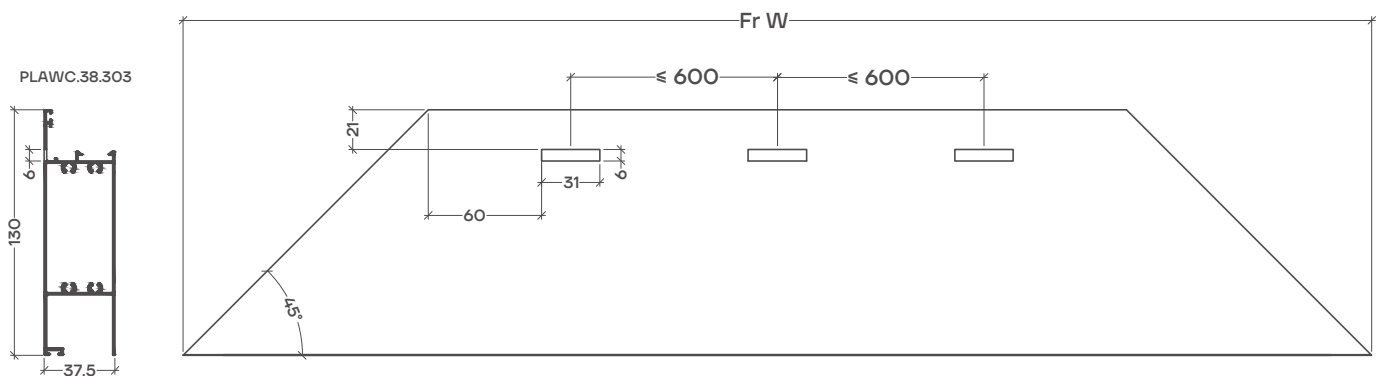

**Note:**

This machining is valid for all the kick-plate profiles of the system

For CNC machine drainage slots is

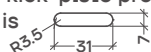

for punching machine is

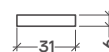

**Additional machining of profiles after cutting  
Casement PLAWC.45.203 - machining for drainage**

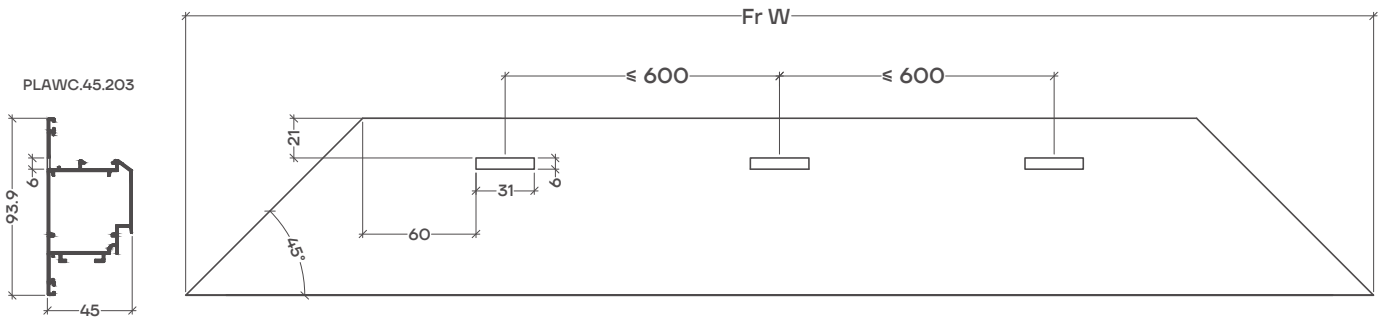

**Note:**

This machining is valid for all the casement profiles of the system

For CNC machine drainage slots is

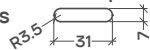

for punching machine is

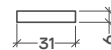

**Additional machining of profiles after cutting  
T-profile PLAWC.38.301 - machining for drainage**

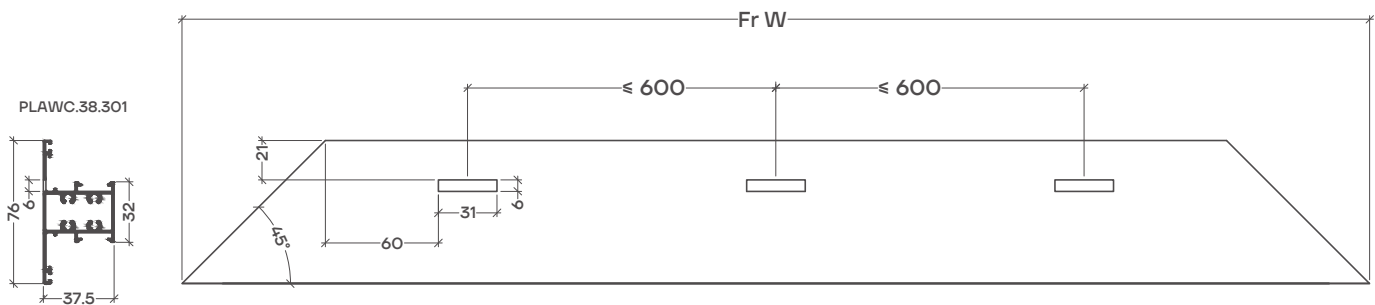

**Note:**

This machining is valid for all the T-profiles of the system

For CNC machine drainage slots is

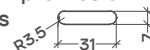

for punching machine is

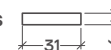



The background is a solid teal color. Overlaid on this are several thin, light yellow lines that form abstract, geometric shapes. These lines create a sense of depth and movement, with some lines extending from the top and bottom edges towards the center. The word "Accessories" is centered in the middle-right area of the page.

# Accessories





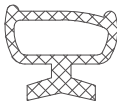
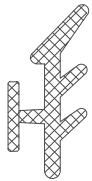
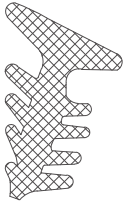
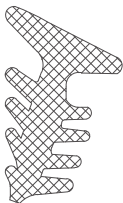
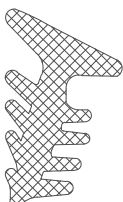

**LIST OF ACCESSORIES**

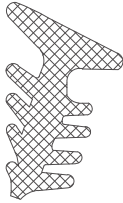
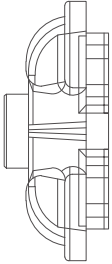
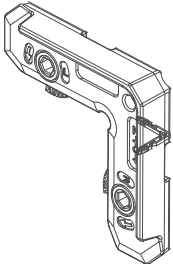
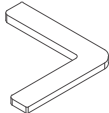
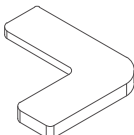
Code	Overview	Colour	Description	Unit of measurement
PLA20.A100		black	internal gasket	m
PLA20.A200		black	external gasket	m
PLA20.A300		black	internal gasket - 1	m
PLA20.A400		black	internal gasket - 1.5	m
PLA20.A500		black	internal gasket - 2	m

**LIST OF ACCESSORIES**

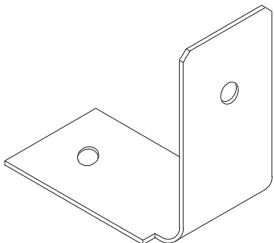
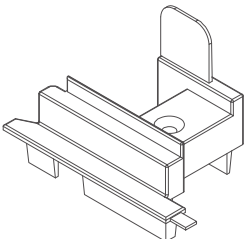
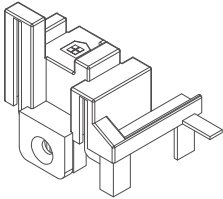
Code	Overview	Colour	Description	Unit of measurement
PLA20.A600		black	internal gasket - 2.5	m
PLA20.A700		mf	alignment corner	pcs
PLA30.A100		mf	alignment corner	pcs
PLA30.A500		mf	alignment corner	pcs
PLA30.A600		mf	alignment corner	pcs

**LIST OF ACCESSORIES**

Code	Overview	Colour	Description	Unit of measurement
PLA30.A300		mf	alignement corner	pcs
PLA10.A100		black	cap for overhung	set
PLA10.A300		black	cap for ending profile	set
PLP20.S216		black	brush	m
		black	glazing pad 1	pcs
		black	glazing pad 2	pcs

# Copyright

Copyright© 2024 LINKIN

The design, structure and content of this catalogue are subject of copyright and the exclusive rights belong to LINKIN. Modifying, copying, publishing, selling or licensing any part or the whole content of this catalogue are strongly prohibited without the permission of LINKIN.

Any unauthorized use of content may violate copyright or other laws.

## Disclaimer

LINKIN is not responsible for any typographical errors, technical inaccuracies and following changes of the content of this catalogue.



proflink.eu