

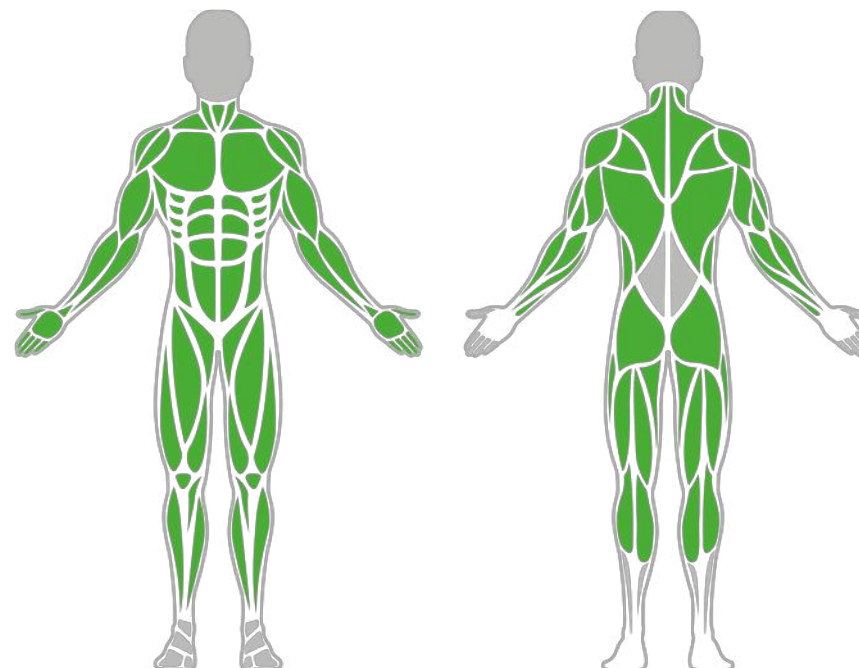

Muscle Groups Focus



Leg Curl

A very useful and straight forward device for strengthening your thighs, legs. Grasping the handles helps you stay fixed in your position while lifting the bottom bar

Attributes

Product code	1-1-310
Certificate	EN 16630
Age group	14 + years
Capacity	1 person
Max. weight load	130 kg
Type	Recreational
Difficulty level	Medium

Side View

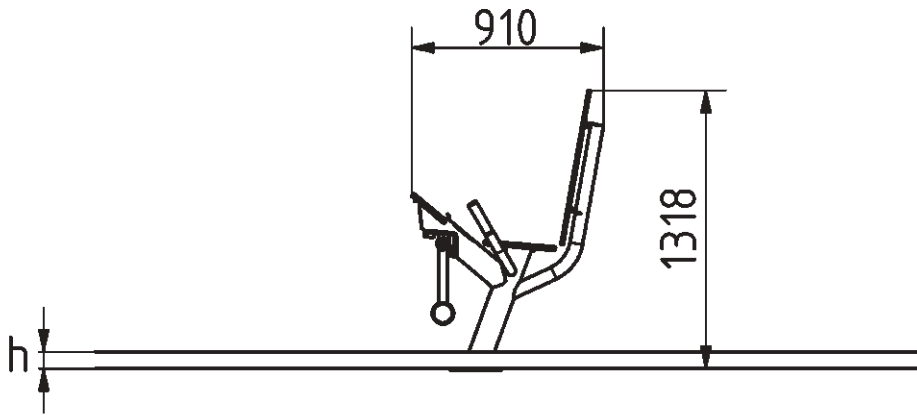

Plan View

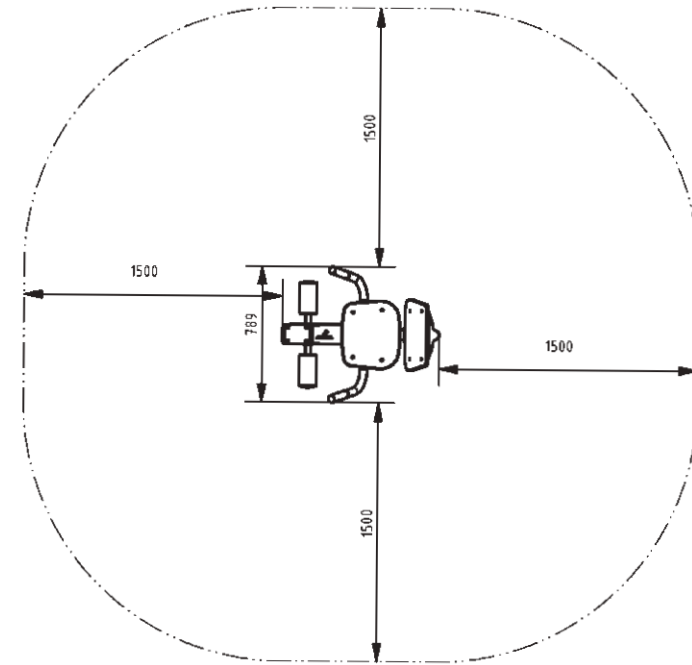

Installation information

Number of installers (concrete)	At least 2 people
Total installation time (concrete)	45-90 min.
Number of installers (equipment)	At least 2 people
Total installation time (equipment)	90-120 min.
Excavation volume	0.5 m ³
Concrete volume	0.5 m ³
Size of the base structure	0,8 x 0,8 x 0,8 m
Anchoring options	Surface mounted
In combined structures, the volume of concrete required varies.	

Technical specification

Safety surface area	Around 1,5 m radius
Net weight	57 kg
Material	S235, KO33
Critic fall height	480 mm
Color options	
For more color options, discuss with your sales representative.	

Warranty

Structure	25-15 years
Steel	5-10 years
Paint	2 years
Plastic	5-10 years
Rubber	1-3 years
Moving parts	2 years
Detailed information in the warranty document	

Material specification

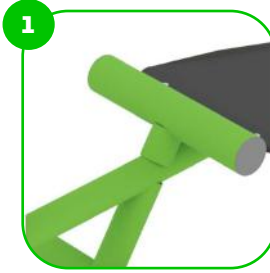

The element is made of high quality S235 steel, which has been cleaned via sandblasting. A corrosion resistant powder coating finish is then applied. Also available with galvanized surface for even greater protection and longevity!

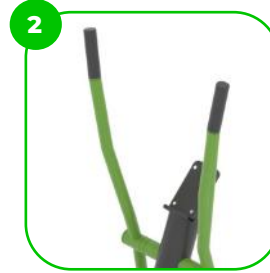

At the end of the arms, the handle is rubber-coated for a more comfortable and secure grip.



The device is equipped with an ergonomic non-slip HDPE phone holder for convenience.

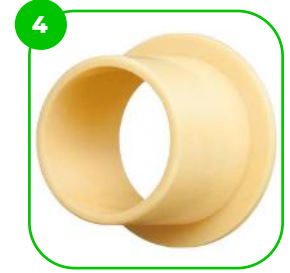

The device is fitted with composite bearings that are weather-resistant. The bearing does not require regular maintenance.

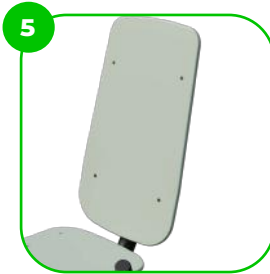

The seats and backrests are made of strong HDPE material. Which is fully heat, moisture and UV resistant.

BESTRONG

