









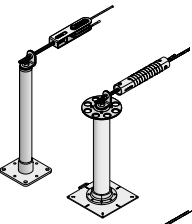
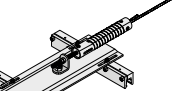
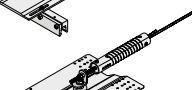
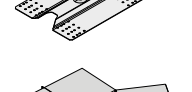

FALL PROTECTION SYSTEMS AND PROTECTIVE EQUIPMENT

SAFETY, FOR INDUSTRY AND CONSTRUCTION

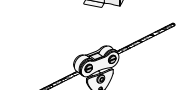

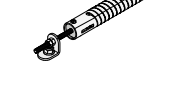
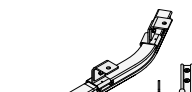
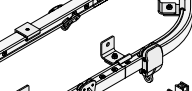
**rothoblaas**

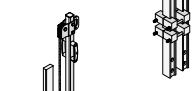
Solutions for Safety

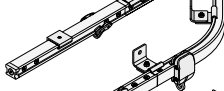
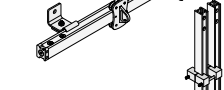

HORIZONTAL LIFELINE

	PATROL + TOWER.....	30
	PATROL + TOWER A2.....	32
	PATROL + TOWER XL.....	34
	PATROL + SOLID.....	36
	PATROL + T-CLAMP.....	38
	PATROL + SHIELD SHIELD 2.....	40
	PATROL + WAVE.....	42
	PATROL + COPPO.....	44
	PATROL + T-ROOF.....	46
	PATROL + BLOCK.....	48
	PATROL + PATROLEND.....	50
	PATROL OVERHEAD.....	52
	PATROL ON WALL.....	54
	PATROL components.....	56

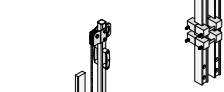
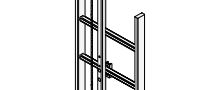
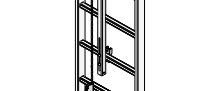
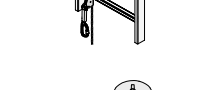
HORIZONTAL AND VERTICAL RAIL

	H-RAIL OVERHEAD.....	62
	H-RAIL ON WALL.....	64
	H-RAIL + SOLID.....	66
	H-RAIL + TOWER.....	68
	H-RAIL ON FLOOR.....	70
	H-RAIL VERTICAL.....	72
	H-RAIL combinations.....	74
	H-RAIL components.....	76

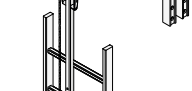
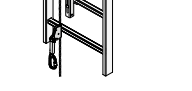

VERTICAL LIFELINE

	VERTIGRIP ON LADDER.....	84
	VERTIGRIP ON WALL.....	86
	VERTIGRIP combinations.....	88
	VERTIGRIP components.....	90

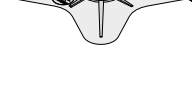









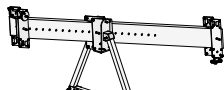

GREEN ROOF LIFELINE

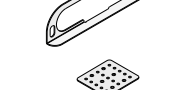
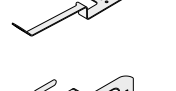
	GREEN LINE.....	94
	GREEN LINE components.....	96

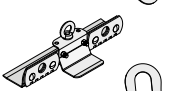
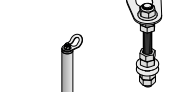
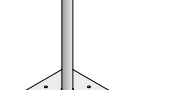
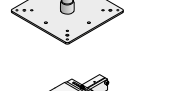
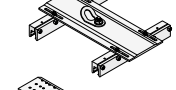
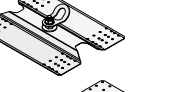
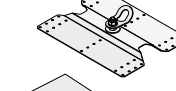
TEMPORARY LIFELINE

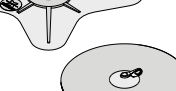
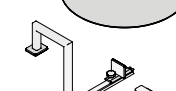
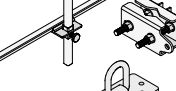
	TEMPORARY.....	98
	HOLD-SYSTEM®.....	99

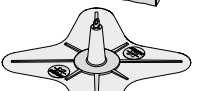
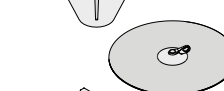
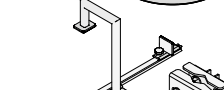
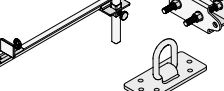
SINGLE POINTS

	WING.....	104
	AOSWS.....	106
	CORNER.....	107
	C-LEVER.....	108
	SOLID.....	110
	LOOP.....	112
	HOOK SPIKE.....	113
	HOOK EVO.....	114
	HOOK EVO 2.0.....	115
	SLIM.....	116
	KITE.....	117
	SIANK.....	118
	AOS.....	119
	AOS01 + TOWER/TOWER A2.....	120
	AOS01 + TOWER XL.....	121
	AOS01 + T-CLAMP.....	122
	AOS01 + SHIELD.....	123
	AOS01 + SHIELD 2.....	124
	AOS01 + WAVE.....	125
	AOS01 + COPPO.....	126
	AOS01 + BLOCK.....	127
	GREEN POINT.....	128
	GLUE ANCHOR.....	129
	MOBILE.....	130
	ROD.....	131
	CARRIER.....	132
	RAPTOR.....	133

COLLECTIVE PROTECTION

137

PERSONAL PROTECTIVE EQUIPMENT 179

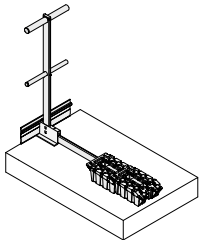

PERMANENT RAILING BARRIERS

BORDER W140

BORDER V/BORDER VD141

BORDER H142

BORDER M143

BORDER Z144

BORDER | components145

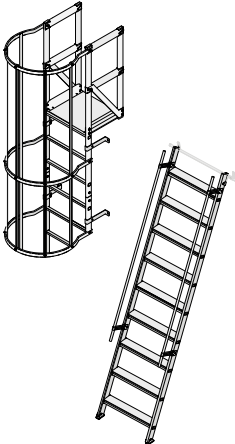

FIXED LADDERS

STEP UP150

STEP UP | components152

PITCHED LADDERS

EASY LAD158

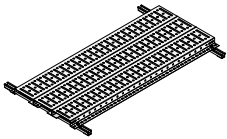

WALKWAYS AND OVERPASSES

ALL WALK160

EASY WALK162

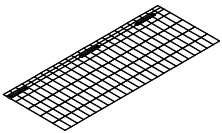

PERMANENT FALL PROTECTION NET

OVERNET164

ROLLNET166

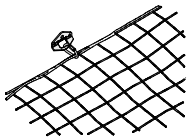

TEMPORARY FALL PROTECTION NETS

HORIZONTAL NET168

VERTICAL NET170

FRAME NET171

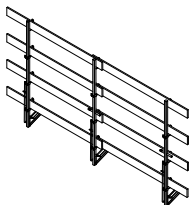

TEMPORARY RAILING BARRIERS

EDGE TEMP 1172

EDGE TEMP 2172

EDGE TEMP 3173

EDGE TEMP 4173

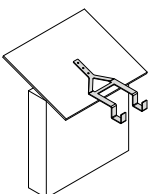

LADDER HOOKS

HANG TEMP174

HANG ROOF174

HANG WALL175

HANG PLAIN175

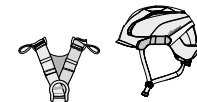

HELMETS

from page180



HARNESSES

from page184



FALL PROTECTION AND POSITIONING

from page193



RETRACTABLE DEVICES

from page197



KIT

from page198

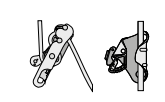

TEMPORARY ANCHOR SYSTEMS

from page200



CONNECTORS

from page202



ROPES AND ACCESSORIES

from page206



DESCENDERS AND CLAMPS

from page208



TRIPODS AND CRANES

from page210

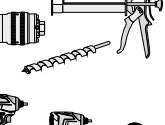

RESCUE

from page215

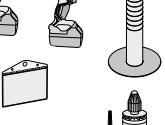

ACCESSORIES

from page216

COMPLEMENTARY PRODUCTS 227

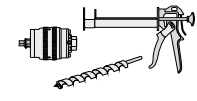

TOOLS

from page230



MACHINES

from page242

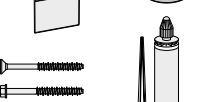

ACCESSORIES

from page246

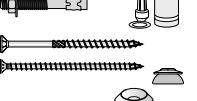

FASTENING ON CONCRETE

from page256

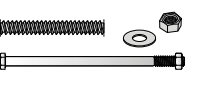

FASTENING ON TIMBER

from page264



THREADED RODS, WASHERS, NUTS AND BOLTS

from page269

THE HIERARCHY OF FALL PROTECTION



1 ELIMINATE THE RISK

Where possible, avoid work at height. Alternatively, install systems and equipment in safe areas free from the risk of falls.

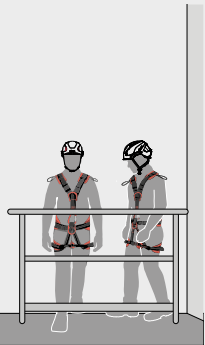

2 COLLECTIVE PROTECTION

If work at a height is unavoidable, minimise the risk of falls by using collective protection such as the Rothoblaas BORDER railing, and avoid unnecessary exposure.

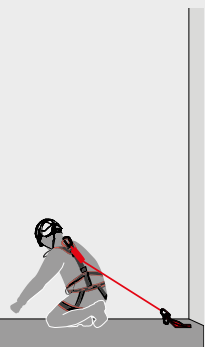

3 PERSONAL PROTECTION

Where the risk of falls cannot be eliminated, use a suitable safety system to minimise the consequences, employing restraint or fall protection systems.



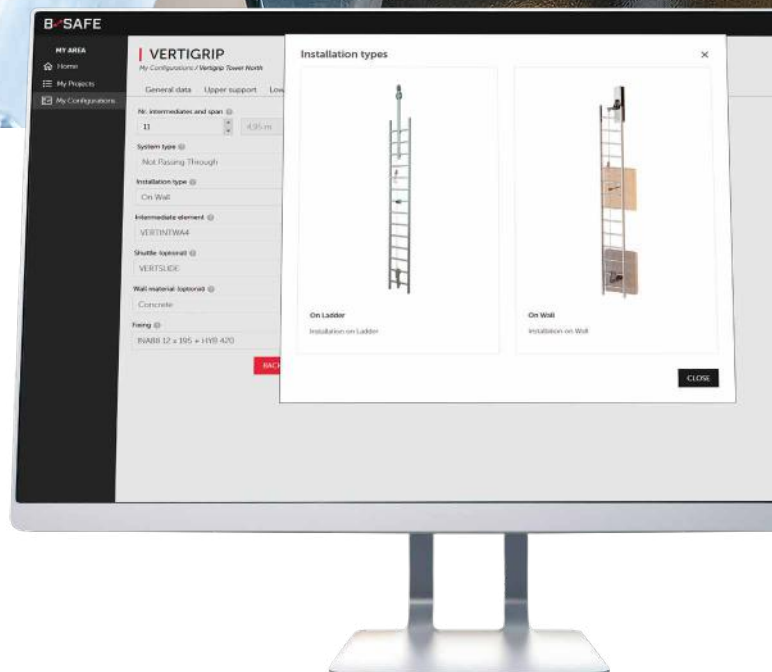

B-SAFE, online too

B-SAFE is the new Rothoblaas platform that lets you design complete fall protection solutions online with ease. With a suite of advanced tools, you can:

- **Customise and optimise projects** to meet all needs.
- **Manage installation and inspection documentation** quickly and accurately.
- **Calculate loads and deflections** to ensure maximum safety.

B-SAFE: a single, user-friendly platform, available anytime.

Design with us at b-safe.rothoblaas.com

rothoblaas.com



rothoblaas

Solutions for Safety

WORK METHODS

RESTRAINT



A personal protection system that prevents the worker from reaching areas at risk of falls from height, keeping them in a safe position by means of devices that limit movement.

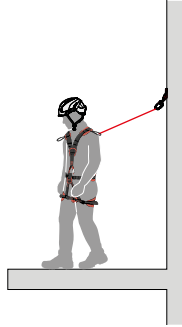

POSITIONING AT WORK



This allows the person to work in tension or restraint, keeping them in a stable and safe position, thus preventing falls.

The worker is supported by personal protective equipment such as harnesses and ropes that ensure safety and stability during work.

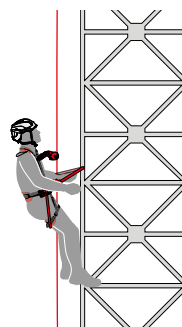

ROPE ACCESS



The worker safely accesses and moves towards the area of work using a work rope and a safety rope, each separately connected to secure anchor points. The system allows safe operation in hard-to-reach areas, such as vertical walls or elevated surfaces, preventing or stopping falls.

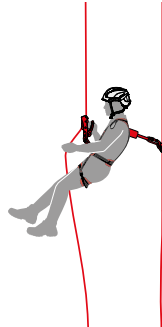

FALL ARREST



A protection system that immediately stops a worker, limiting the impact force on their body during the arrest. It consists of devices such as harnesses, ropes and anchors, distributing the impact energy in a controlled manner.

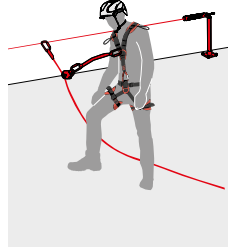

RECOVERY OR RESCUE



The set of procedures necessary to assist and safely recover a worker in an emergency situation, such as a fall or illness, during work at height. These operations allow a person to save themselves or others using specific equipment and applying rapid response protocols.

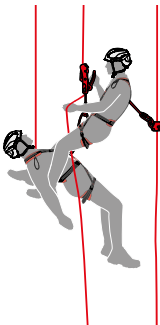

RISK OF FALLING FROM HEIGHT

VERTICAL CLEARANCE

When working in fall protection, the **VERTICAL CLEARANCE** must be taken into account:

$$T_A = L_C + L_{max} + H_A + D_{SIC} \quad [m]$$

T_A vertical clearance

L_C length of rope/device between the permanent anchor point and harness anchor point

L_{max} maximum extension of the energy absorber (maximum 1,75 m)

H_A 1.50 m average height above the operator's feet from the anchor point of the harness

D_{SIC} safety distance (minimum 1 m)

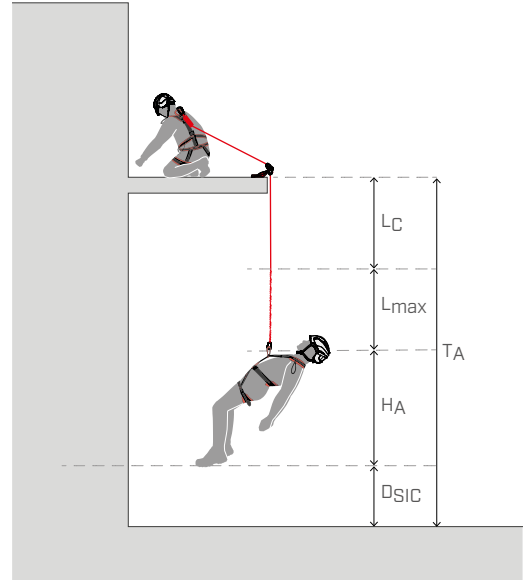

FALL FACTOR

The **FALL FACTOR** expresses the degree of danger of a fall:

$$F_C = H / L$$

F_C fall factor

H height fallen during the fall

L length of the rope / connection device



$2 > F_C > 0$ where $F_C = 2$ is the **maximum fall factor**

✓ Minimal risk of harm to the operator's body

! Risk of harm to the operator's body

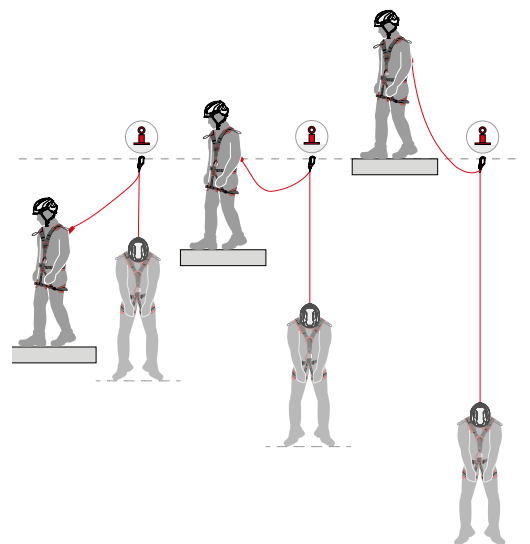
✗ High risk of harm to the operator's body



	$F_C = 0$	$F_C = 1$	$F_C = 2$
 without energy absorber	✓	!	✗
 with energy absorber	✓	✓	!

PENDULUM EFFECT

The "pendulum effect" refers to a lateral movement that occurs during a fall when the anchor is not located vertically with respect to the worker.

This can be a dangerous situation as it may cause the operator to collide with obstacles along the fall trajectory.

How to prevent the pendulum effect?

1. Plan the work and analyse the risk of falls
2. Position the anchor vertically above the operator
3. Use appropriate Personal Protective Equipment (PPE)

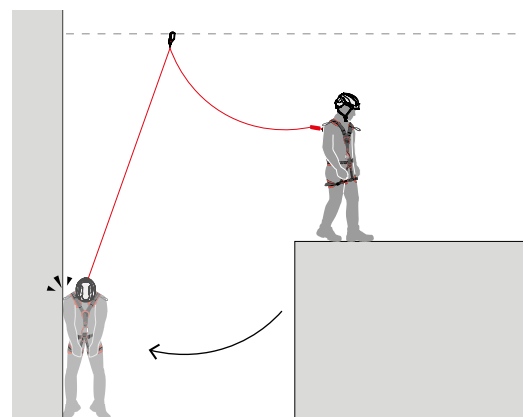

WORK CONTEXTS

CONFINED SPACES



CONSTRUCTION SITE



FAÇADE



AERIAL WORK PLATFORM



VERTICAL ACCESSES



PYLONS



PITCHED ROOF



INDUSTRIES



FLAT ROOF



FAÇADE

FAÇADE ACCESS AND MAINTENANCE



PERMANENT ANCHOR POINTS



PATROL
HORIZONTAL
LIFELINE

▶ page 28



WING
ANCHOR POINT FOR
ROPE ACCESS WORK

▶ page 104

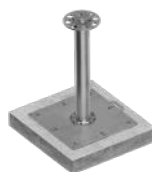

SOLID
RIGID ANCHOR POINT
FOR ROPE ACCESS
WORK

▶ page 110



H-RAIL
RAIL SYSTEM FOR
HORIZONTAL AND
VERTICAL USE

▶ page 60



C-LEVER
DIVERSION SYSTEM
FOR ROPE ACCESS
AND FAÇADE WORK

▶ page 30

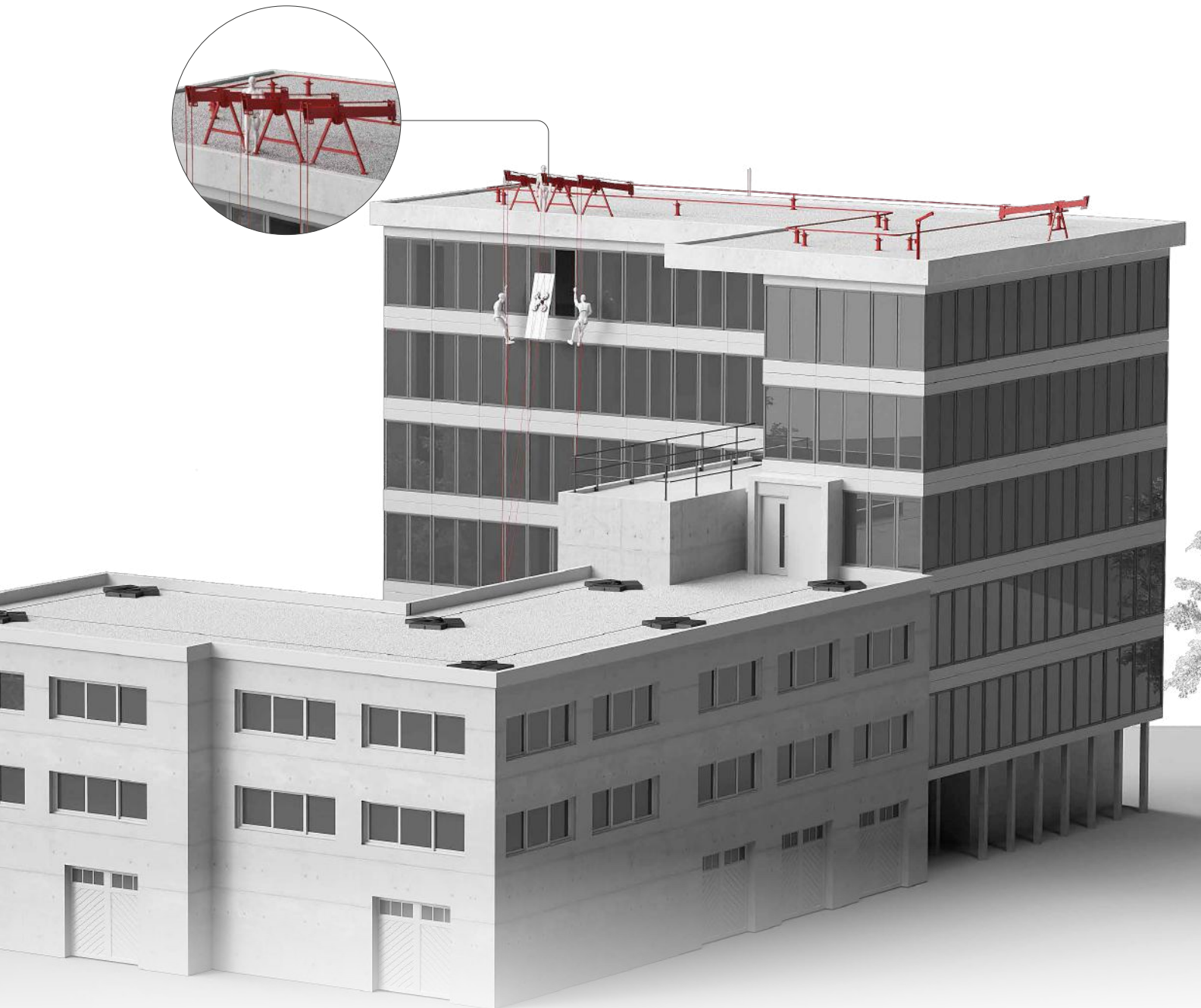

PPE



HERO

HELMET FOR WORK AT HEIGHT, ON CONSTRUCTION SITES OR IN INDUSTRIAL AREAS

▶ page 180



OLYMPIA

FULL PROFESSIONAL HARNESS FOR ROPE ACCESS WORK

▶ page 184



TOOLGRAB

FALL PROTECTION FOR TOOLS

▶ page 216



EDGEPRO

LIGHT ALUMINIUM ALLOY ROLLER FOR ROPE MOVEMENT

▶ page 207



PLANK

SEAT FOR EXTENDED SUSPENSION WORK

▶ page 192

INDUSTRIAL AND RESIDENTIAL ROOFS

WORK ON FLAT AND PITCHED ROOFS

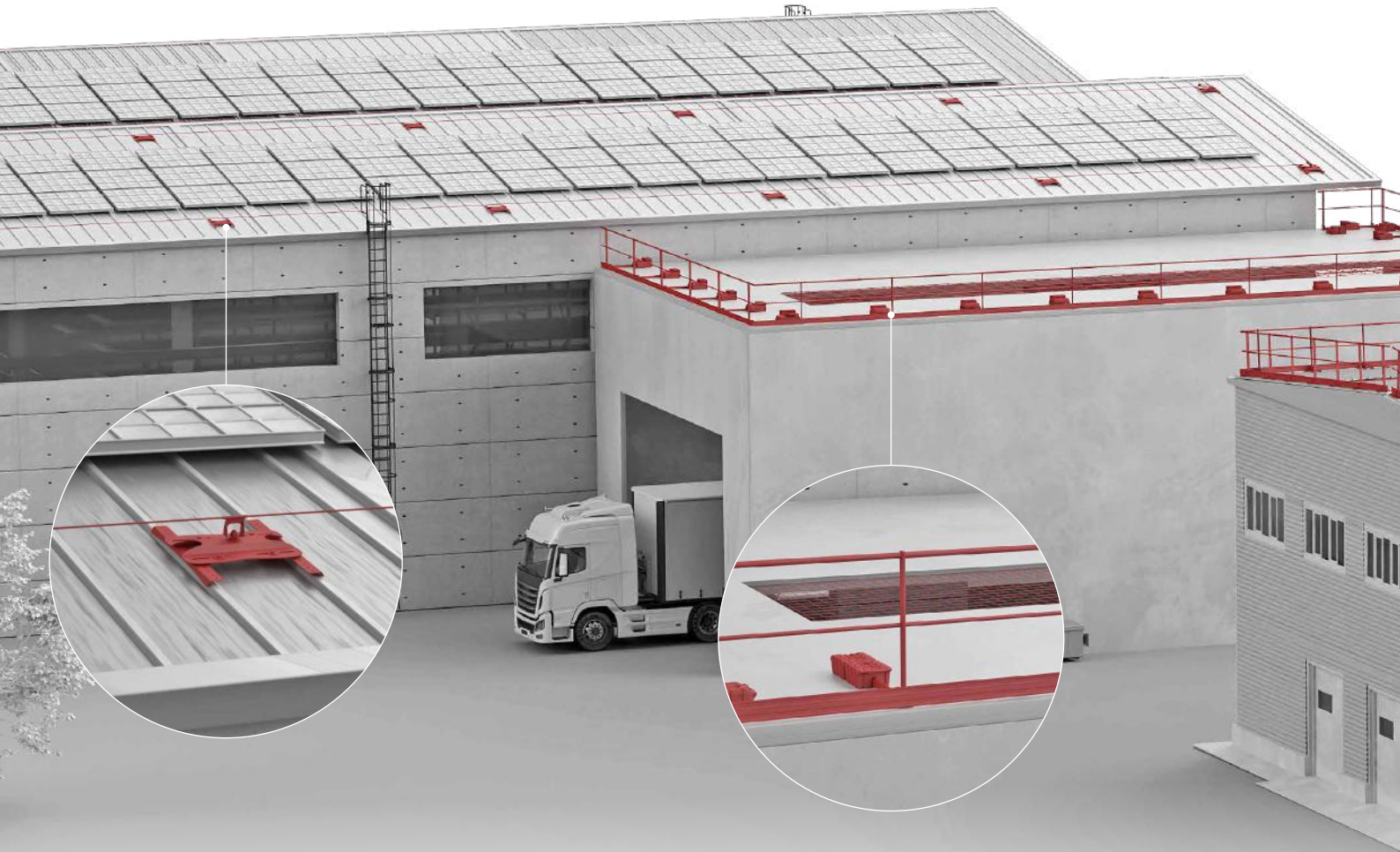

COLLECTIVE PROTECTION

PERMANENT ANCHOR POINTS

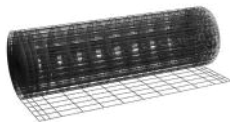

BORDER

ALUMINIUM
PERMANENT
AND TEMPORARY
RAILINGS

▶ page 138

OVERNET

PERMANENT FALL
PROTECTION SYSTEM

▶ page 164

EASY WALK

WALKWAYS SYSTEMS
FOR TRAPEZOIDAL
METAL SHEET ROOFS

▶ page 162

PATROL

HORIZONTAL
LIFELINE

▶ page 28

ANCHOR POINTS

see the full range of
products

▶ page 104

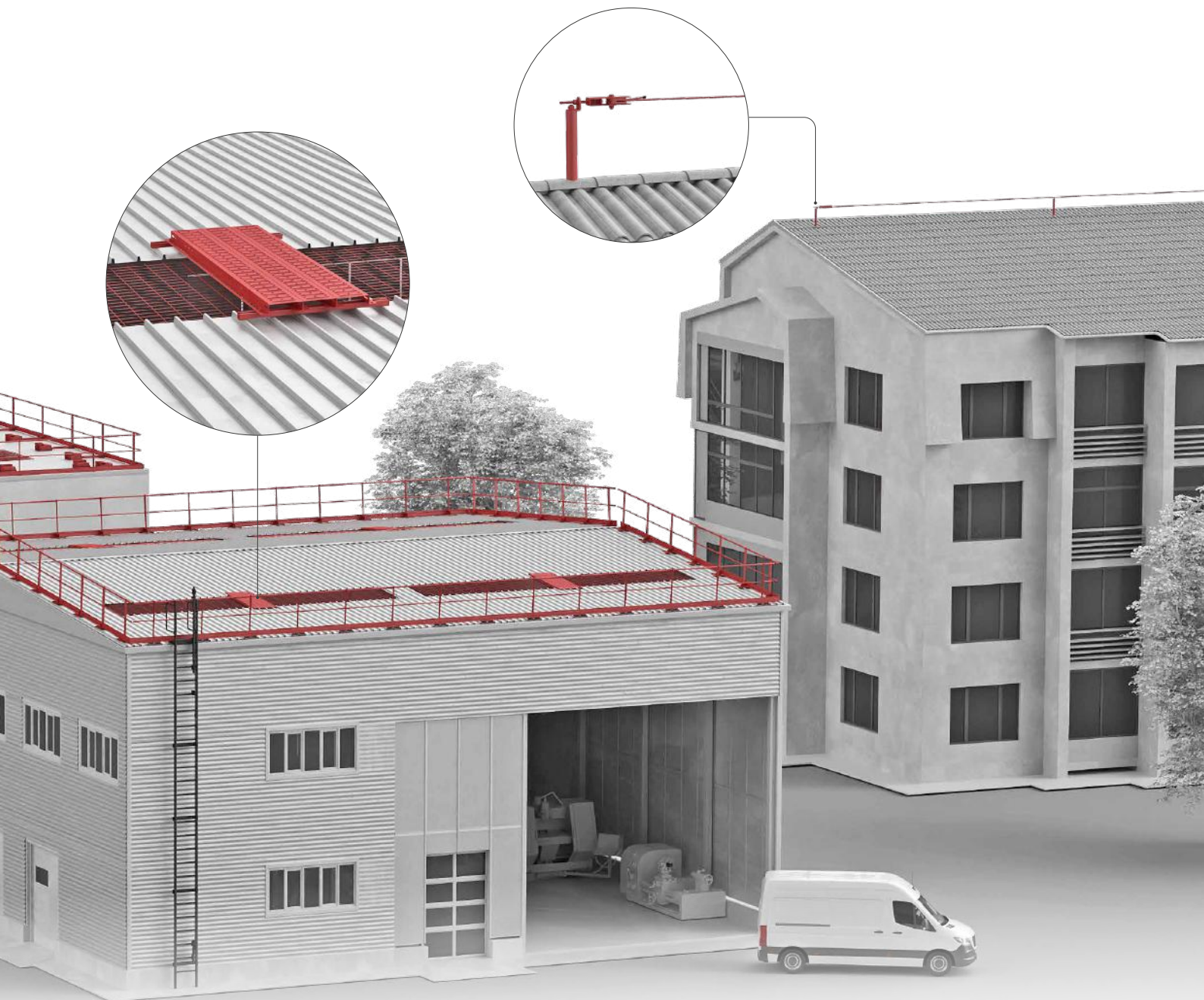

PPE



HERO

HELMET FOR WORK AT HEIGHT, ON CONSTRUCTION SITES OR IN INDUSTRIAL AREAS

▶ page 180



HARNESSES

see the full range of products

▶ page 184



DOUBLE SICUROPE

DOUBLE ARM ROPE WITH ENERGY ABSORBER

▶ page 193



ROPE 1

SEMI-STATIC ROPE WITH SEWN ENDS AND AUTOMATIC CARABINER

▶ page 195



BACK

FALL ARRESTER

▶ page 196

VERTICAL ACCESSES AND WALKWAYS

PYLONS / SILOS / ROOFS / WIND TURBINES / AERIAL LIFTS

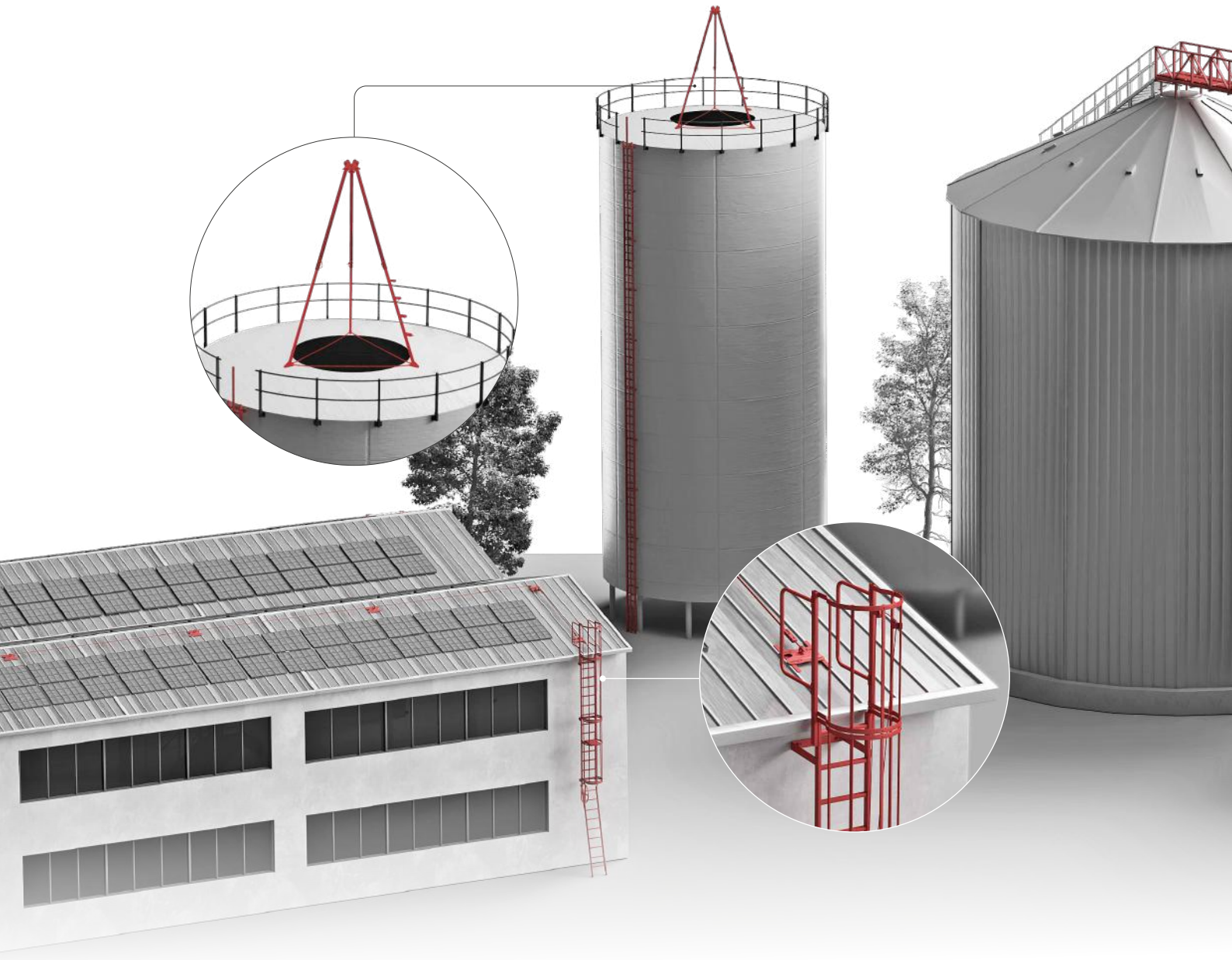

COLLECTIVE PROTECTION

ANCHOR SYSTEMS



STEP UP

CAGED
LADDERS

▶ page 150

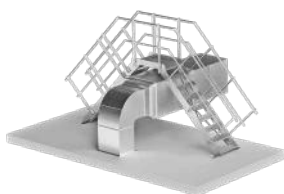

ALL WALK

WALKWAYS AND
OVERPASSES

▶ page 160



VERTIGRIP

VERTICAL
LIFELINE

▶ page 82



H-RAIL

RAIL SYSTEM FOR
HORIZONTAL AND
VERTICAL USE

▶ page 60



TRI

MOBILE DEVICE WITH
THREE FEET FOR
LOWERING, LIFTING
AND RECOVERY

▶ page 210

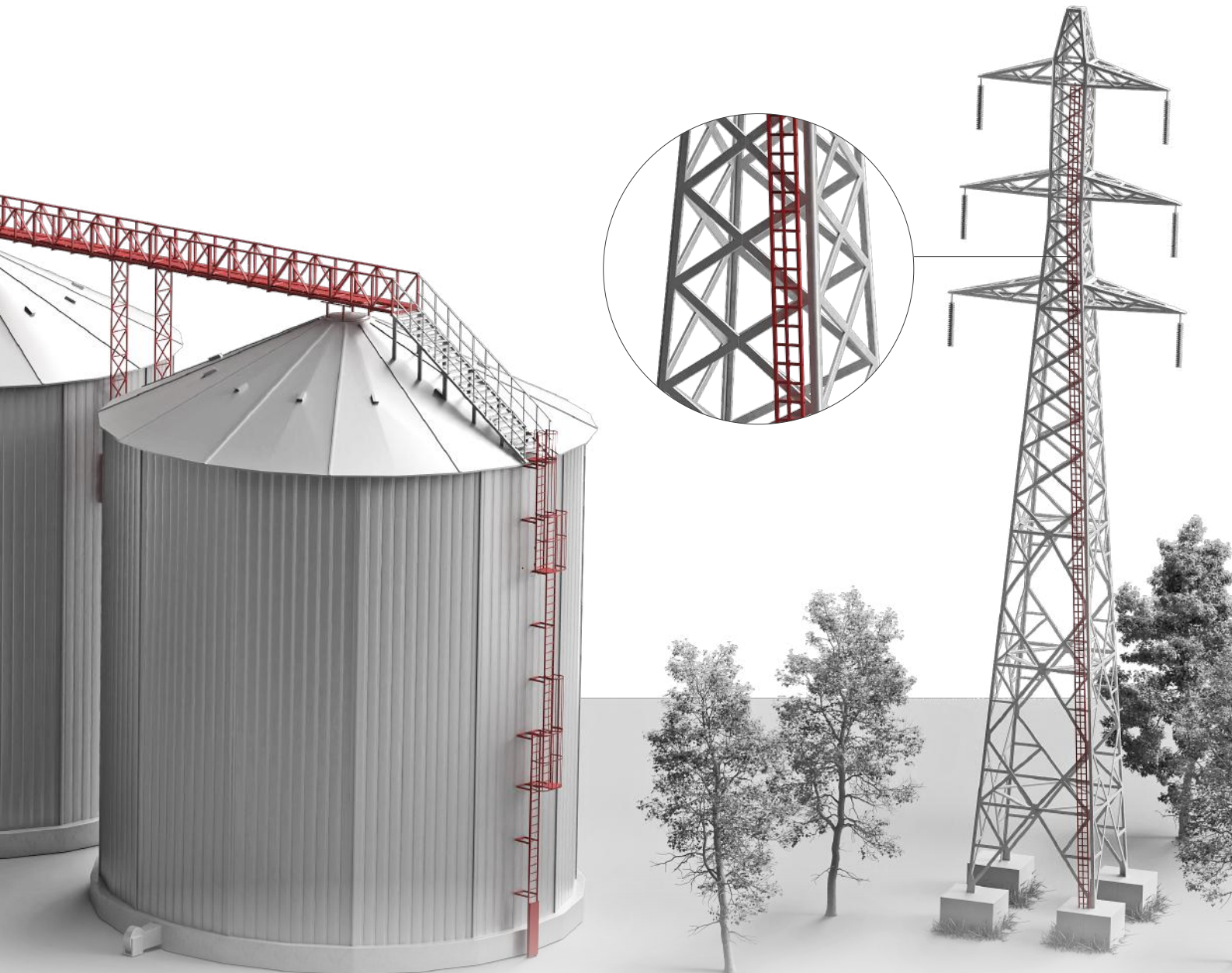

PPE



HERO

HELMET FOR WORK AT HEIGHT, ON CONSTRUCTION SITES OR IN INDUSTRIAL AREAS

▶ page 180



SPARTA

COMPLETE PROFESSIONAL HARNESS

▶ page 186



ROPE 1

SEMI-STATIC ROPE WITH SEWN ENDS AND AUTOMATIC CARABINER

▶ page 195



BACK

FALL ARRESTER

▶ page 196



TOOLGRAB

FALL PROTECTION FOR TOOLS

▶ page 216

INDUSTRIES

WORK ON MACHINERY, AUTOMATIC WAREHOUSES, OVERHEAD CRANES, VEHICLE LOADING/UNLOADING

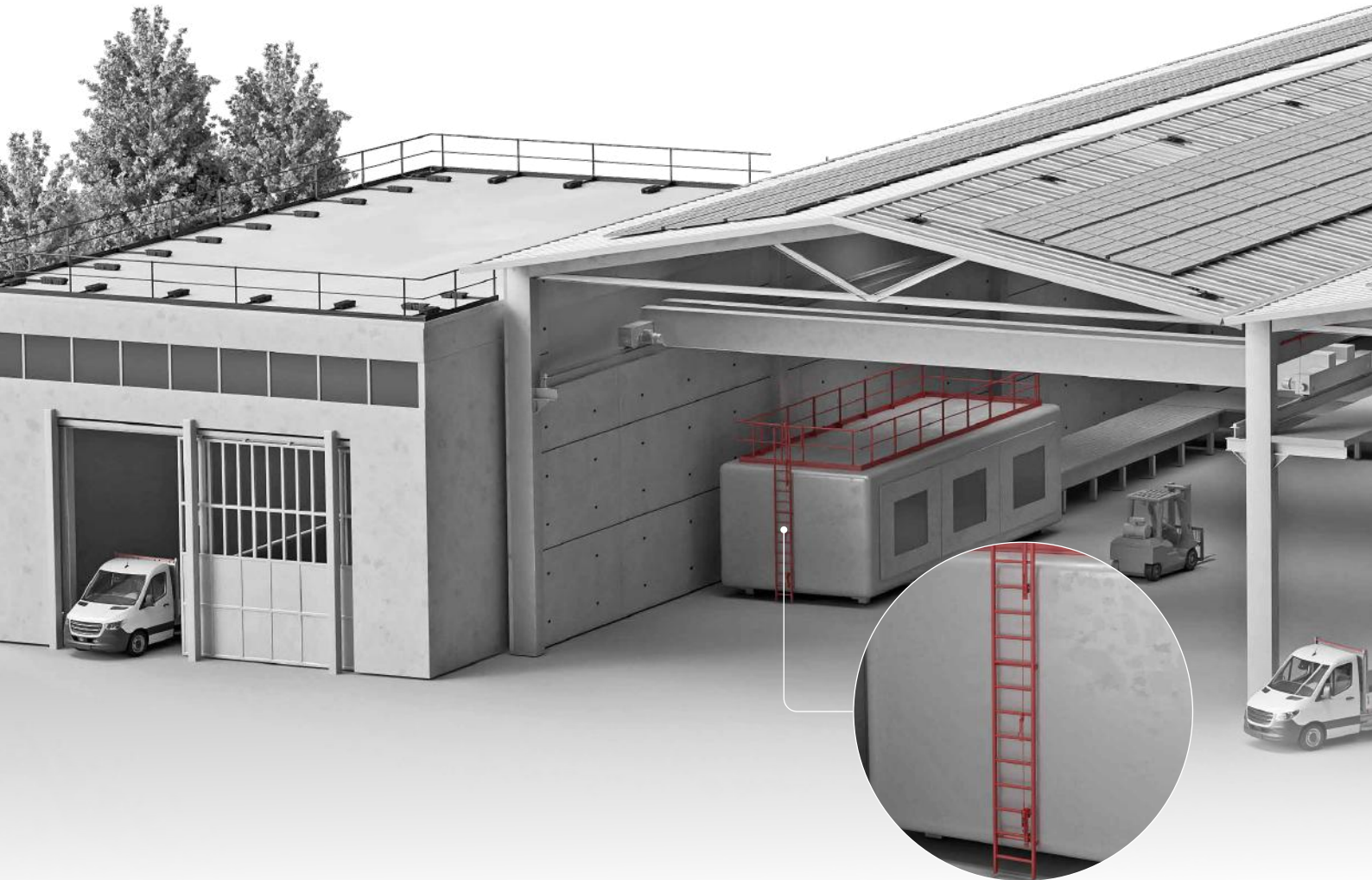

COLLECTIVE PROTECTION



BORDER

ALUMINIUM
PERMANENT
AND TEMPORARY
RAILINGS

▶ page 138



STEP UP

CAGED
LADDERS

▶ page 150



HERO

HELMET FOR WORK
AT HEIGHT, ON
CONSTRUCTION SITES
OR IN INDUSTRIAL
AREAS

▶ page 180



HARNESSES

see the full range
of products

▶ page 184



FALL BLOCK

RETRACTABLE
DEVICE WITH STEEL
CABLE

▶ page 197

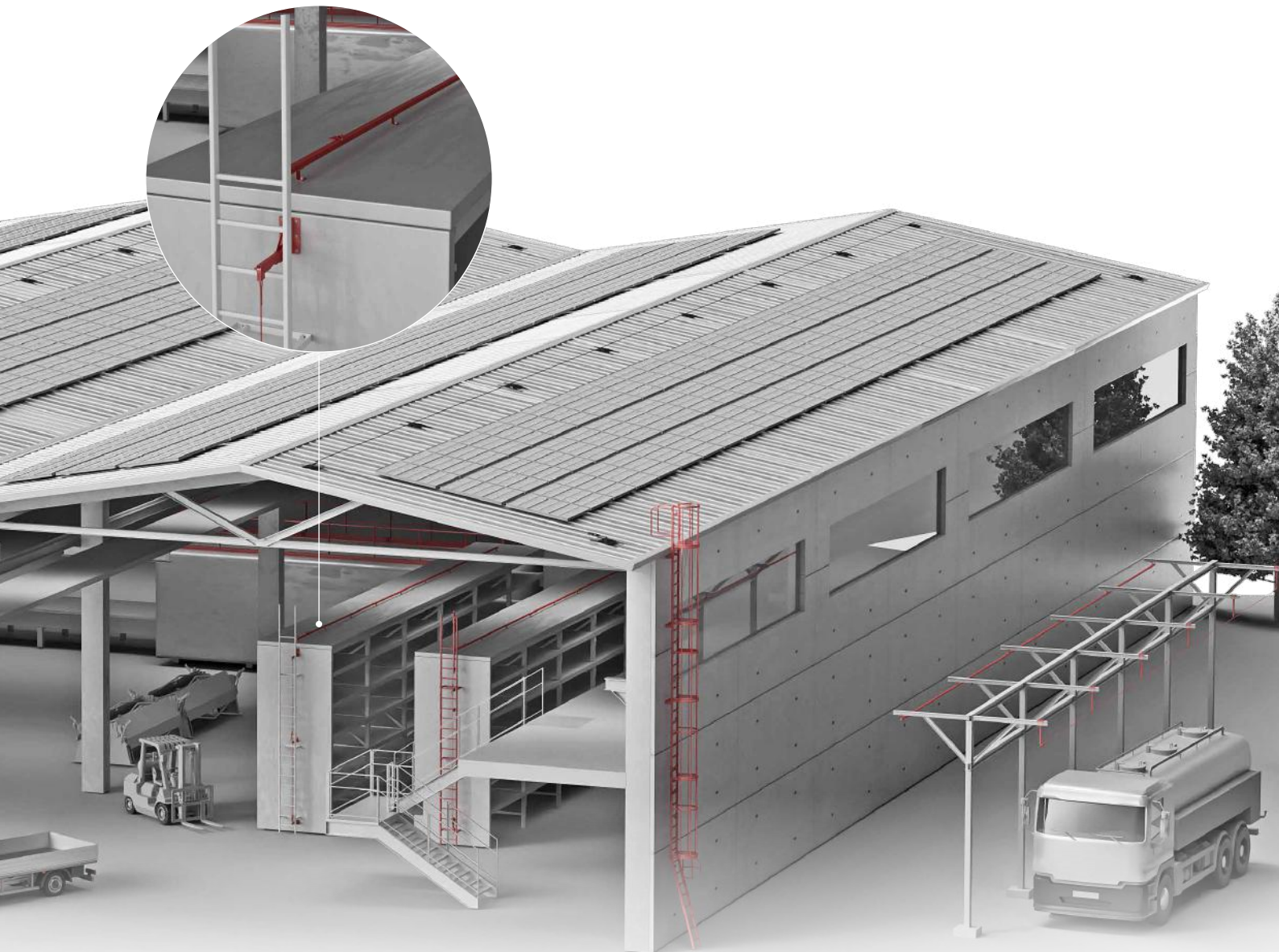

PERMANENT ANCHOR POINTS



PATROL
HORIZONTAL
LIFELINE

▶ page 28



H-RAIL
RAIL SYSTEM FOR
HORIZONTAL AND
VERTICAL USE

▶ page 60



VERTIGRIP
VERTICAL
LIFELINE

▶ page 82



KITE
ANCHOR POINT

▶ page 117



CARRIER
SLIDING ANCHOR FOR
STEEL STRUCTURES

▶ page 132

CONSTRUCTION SITE

TEMPORARY COLLECTIVE PROTECTION FOR CONSTRUCTION SITES

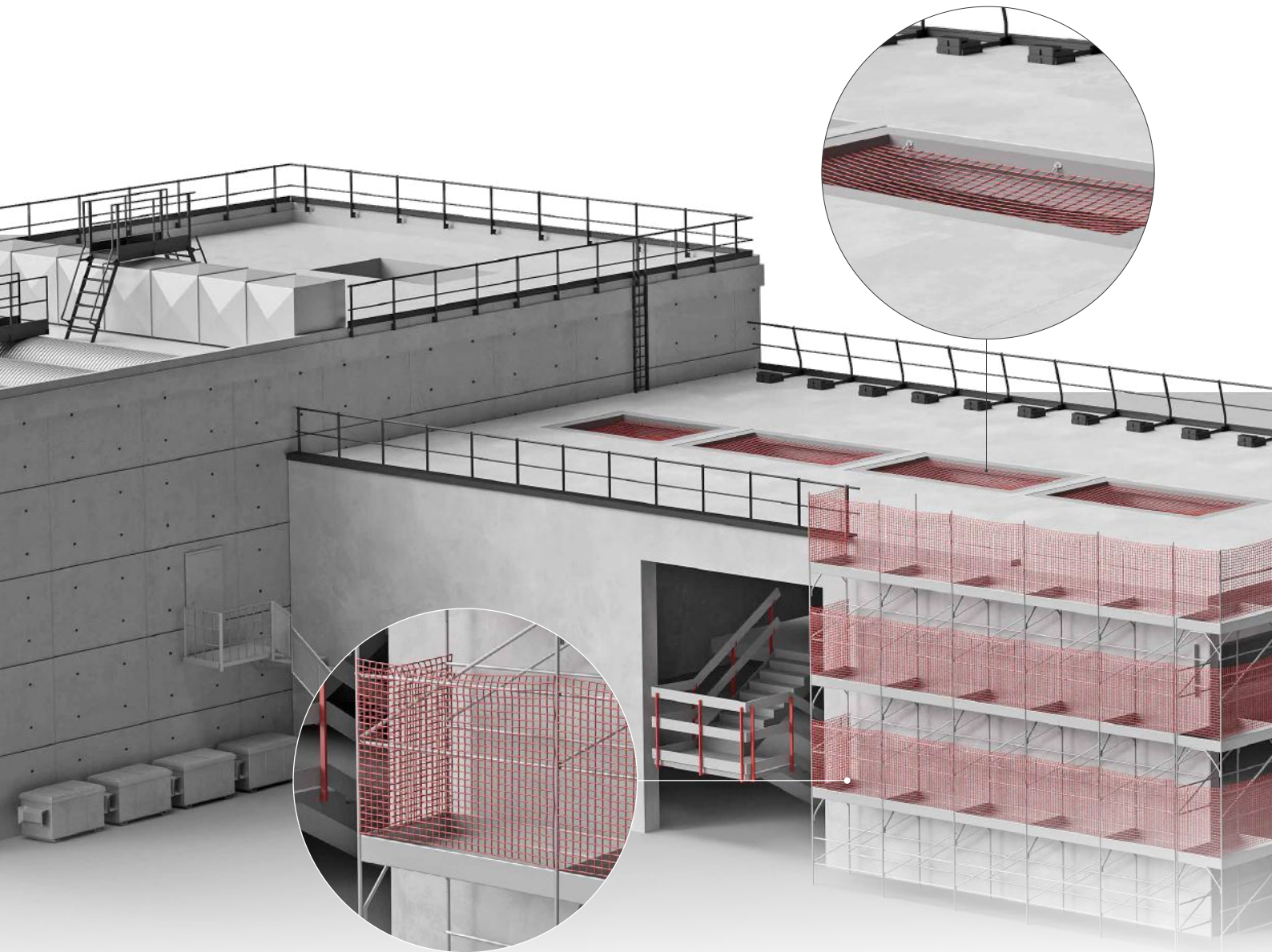

COLLECTIVE PROTECTION

ANCHOR SYSTEMS



VERTICAL NET

VERTICAL
POLYPROPYLENE
FALL PROTECTION
SAFETY NET

▶ page 170



HORIZONTAL NET

HORIZONTAL
POLYPROPYLENE
FALL PROTECTION
SAFETY NET

▶ page 168



FRAME NET

FALL PROTECTION
SAFETY NET WITH
FRAME

▶ page 171



KITE

ANCHOR POINT

▶ page 117



ROD

ANCHOR POINT FOR
STEEL STRUCTURES

▶ page 131

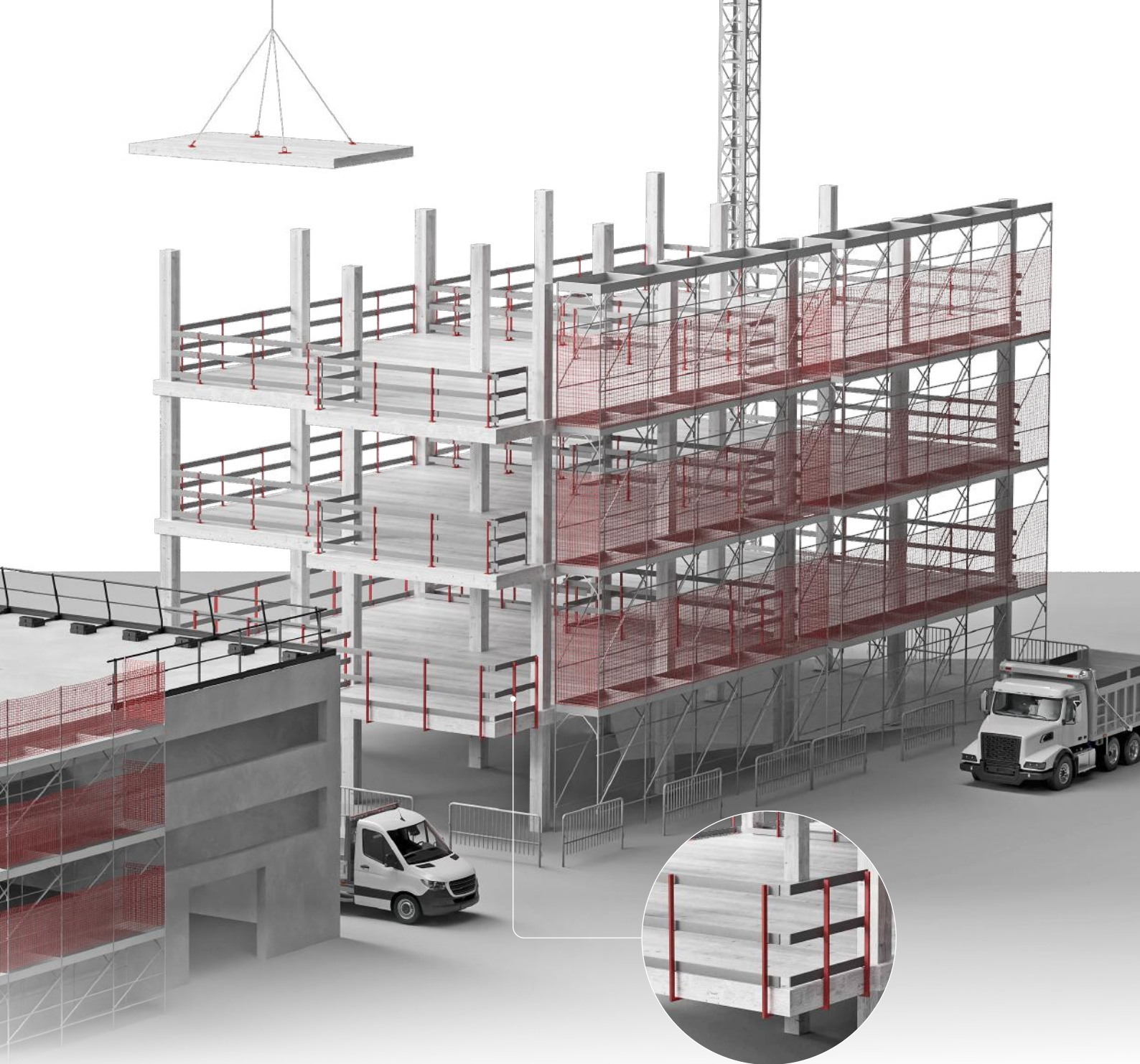

PPE



HELMETS

see the full range of products

▶ page 180



HARNESSES

see the full range of products

▶ page 184



HOLD-SYSTEM®

TEMPORARY HORIZONTAL ANCHORING DEVICE

▶ page 99



STRAP

RETRACTABLE DEVICE

▶ page 197



SCAFFOLD DUO

DOUBLE ARM ROPE WITH ENERGY ABSORBER

▶ page 193

PRODUCT

From the background of construction products to EN 17235 ready

For over 30 years, Rothoblaas has pioneered innovation in the construction market with solutions for timber and hybrid structures as well as safety, offering cutting-edge products for the building and industrial sectors.



SAFE EVERYWHERE

Our products and systems comply with the latest and most widely adopted regulations and are designed according to the most advanced technological standards.

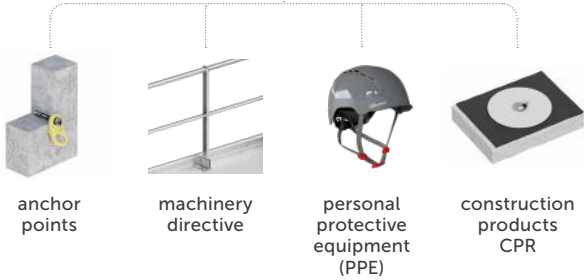
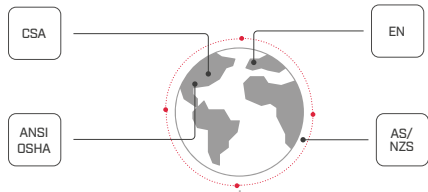

GRAVITY LAB & SAFE C.LAB

We perform product tests in our in-house laboratory. The certifications are issued by third-party organisations.



COMPLETE SOLUTIONS

Our products are supplied complete with all the necessary documentation.



- declaration of conformity
- certificate
- installation manual
- safety regulations



PRODUCT DEVELOPMENT

All stages of development and testing for our products are managed in-house.

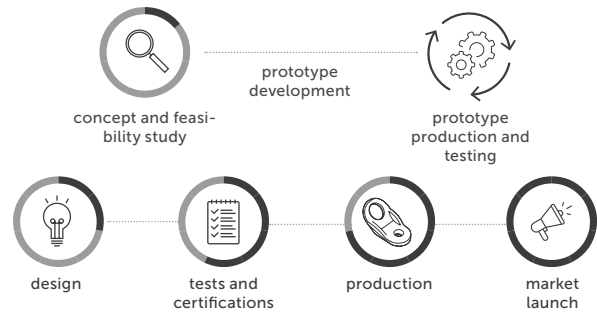

DURABILITY & SUSTAINABILITY

Made primarily from steel and aluminium, our products are durable with a very low environmental impact.

DESIGN TO LAST



When used correctly and regularly inspected, our products can have a lifespan equivalent to the service life of the building.

DESIGNED TO REDUCE THEIR IMPACT



SUPPORT

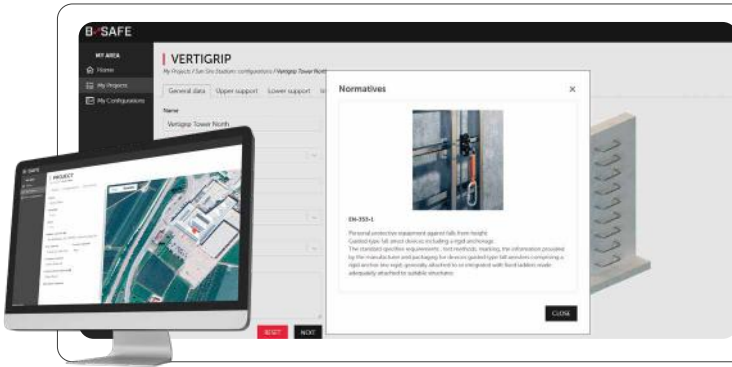

B-SAFE CONFIGURATOR

The multifunctional Rothoblaas portal allows:

- Project configuration complete with fall protection solutions
- Calculation of loads and deflections
- Management of installation and servicing documentation

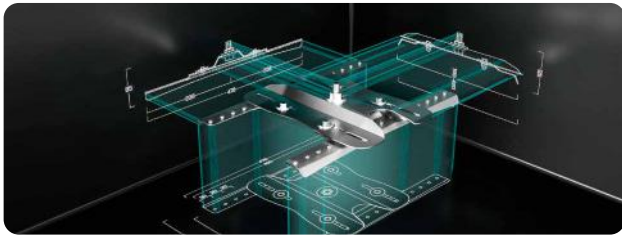

ONLINE RESOURCES

- Building Information Modelling (BIM) on ProLib
- CAD files and specification items available on our website



INSTALLATION VIDEO

Assembly instructions for our fall protection system can be found on our YouTube channel.



SERVICES AND TRAINING



TECHNICAL CONSULTANCY

Dedicated support for engineers, technicians and installers on the positioning and correct choice of fastening systems.

A personalised consultation for each stage of the design, development and maintenance of our systems.



ROTHOSCHOOL

In-person and online training courses for fall protection system installers with the "Safety Learning" program.

ROTHOSCHOOL ON TOUR

We bring "SAFETY" courses closer to you. Learn more on our website.



Discover our in-person or online offering with the "Safety Learning" program

➔ www.rothoblaas.com/school



LIFELINE AND RAIL SYSTEMS

LIFELINE AND RAIL SYSTEMS

HORIZONTAL LIFELINE



PATROL + TOWER

page 30 ◀



PATROL + TOWER A2

page 32 ◀



PATROL + TOWER XL

page 34 ◀



PATROL + SOLID

page 36 ◀

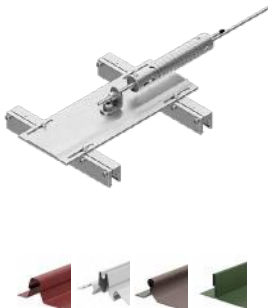

PATROL + T-CLAMP

page 38 ◀

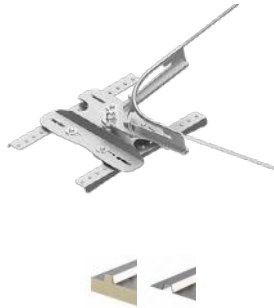

PATROL + SHIELD | SHIELD 2

page 40 ◀

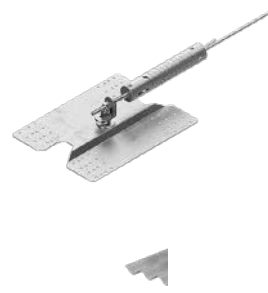

PATROL + WAVE

page 42 ◀

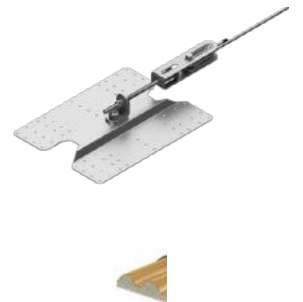

PATROL + COPPO

page 44 ◀

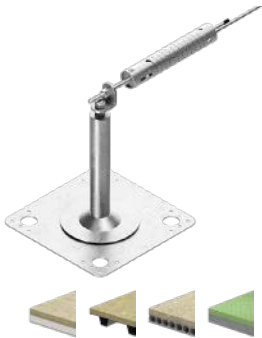

PATROL + T-ROOF

page 46 ◀

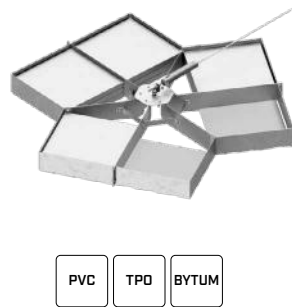

PATROL + BLOCK

page 48 ◀



PATROL + PATROLEND

page 50 ◀



PATROL OVERHEAD

page 52 ◀



PATROL ON WALL

page 54 ◀



H-RAIL OVERHEAD

page 62 ◀



H-RAIL ON WALL

page 64 ◀



H-RAIL + SOLID

page 66 ◀



H-RAIL + TOWER

page 68 ◀



H-RAIL ON FLOOR

page 70 ◀



H-RAIL VERTICAL

page 72 ◀



TEMPORARY

page 98 ◀



GREEN LINE

page 94 ◀

GREEN ROOF LIFELINE



HOLD-SYSTEM®

page 99 ◀

TEMPORARY LIFELINE



VERTIGRIP ON WALL

page 86 ◀



VERTIGRIP ON LADDER

page 84 ◀

HORIZONTAL AND VERTICAL RAIL

VERTICAL LIFELINE

PATROL

HORIZONTAL LIFELINE

MODULAR, SIMPLE, SAFE SYSTEM.

With our PATROL LIFELINE system, horizontal, overhead or façade life-lines, both through and overhead, are child's play. Thanks to dedicated supports, the system can be quickly installed on timber, metal or concrete substrates. Furthermore, a wide range of specific accessories ensures all your design needs can be easily met.



SLIDING DEVICE

	SLIDE1	SLIDE1 A4	SLIDE2	SLIDE2 A4	OHSLIDE	OHSLIDE A4
material	A2 AISI 304	A4 AISI 316	A2 AISI 304	A4 AISI 316	A2 AISI 304	A4 AISI 316
certification	EN 795:2012 C UNI 11578:2015 C	EN 795:2012 C UNI 11578:2015 C	EN 795:2012 C UNI 11578:2015 C	EN 795:2012 C UNI 11578:2015 C	EN 795:2012 C UNI 11578:2015 C	EN 795:2012 C UNI 11578:2015 C
removable	✓	✓			✓	✓
overhead					✓	✓
on wall	✓	✓	✓	✓		
through	✓	✓	✓	✓	✓	✓

BENEFITS OF ASSEMBLY TOOLS

The design is simple and the components are easy to assemble. All parts can be installed using common, low-cost tools. There are no crimped fastenings, so no expensive crimping machines or crimp control tools are required.

✓

SOCKET
BUSHINGS AND BITS

▶ page 234

BEAR
TORQUE WRENCH

▶ page 235

CANARY
SINGLE-HANDED
SHEARS FOR WIRE
ROPES

▶ page 236

✗

CRIMPING
MACHINES

CRIMP TOOL TEST

KEY POINTS

EASE OF ASSEMBLY

All PATROL components can be easily installed in just a few steps thanks to the convenient manual, available in 24 languages, and the assembly video available on our website.



CABLE TENSIONING

The double end element, which functions as both an absorber and a tensioner, facilitates cable assembly and well-distributed tensioning, even on long lines with multiple curves.

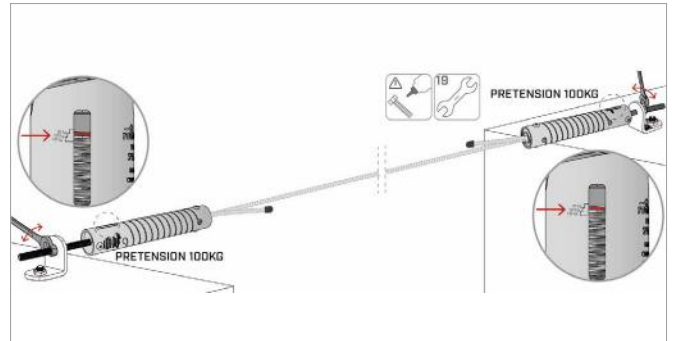

ENERGY ABSORPTION

Thanks to the SPEAREVO absorber-tensioner, it is possible to obtain maximum spans of up to 15 metres between supports, reducing stress on the end elements and, consequently, on the fastenings to the substructure.

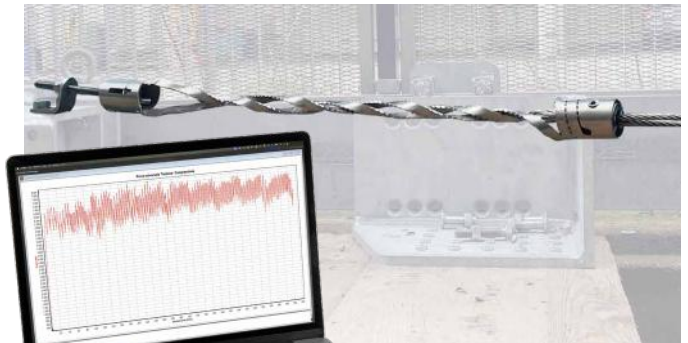

EXPANSION CONTROL

The SPEAR and SPEAREVO end elements, featuring springs on both ends, ensure the system is able to compensate for cable expansion caused by fluctuating temperatures between summer and winter, protecting the supports from potential damage.



SYSTEM INSPECTION

All components of the PATROL system are visible. In just a few steps, the system can easily be serviced every 12 months after the initial installation.

Cable inspection and re-tensioning operations are just as simple to perform.



PATROL + TOWER

LIFELINE ON SUPPORT FOR TIMBER, CONCRETE AND STEEL ROOFS

ADAPTABLE

Support height between 300 and 800 mm to adapt to different roofing thicknesses.

MINIMALIST DESIGN

Small-sized cylindrical support to minimise the visual impact on the roof.

EFFECTIVE

Controlled deformation device to reduce the load on the fastening systems and structure.

EN 795:2012 C	CEN/TS 16415:2013	UNI 11578:2015 C	AS/NZS 1891.2:2001	AS/NZS 1891.4:2009
---------------	-------------------	------------------	--------------------	--------------------



MAXIMUM NUMBER OF USERS



LOAD DIRECTION



TYPES OF APPLICATION

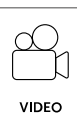

PATROL LIFELINE COMPONENTS

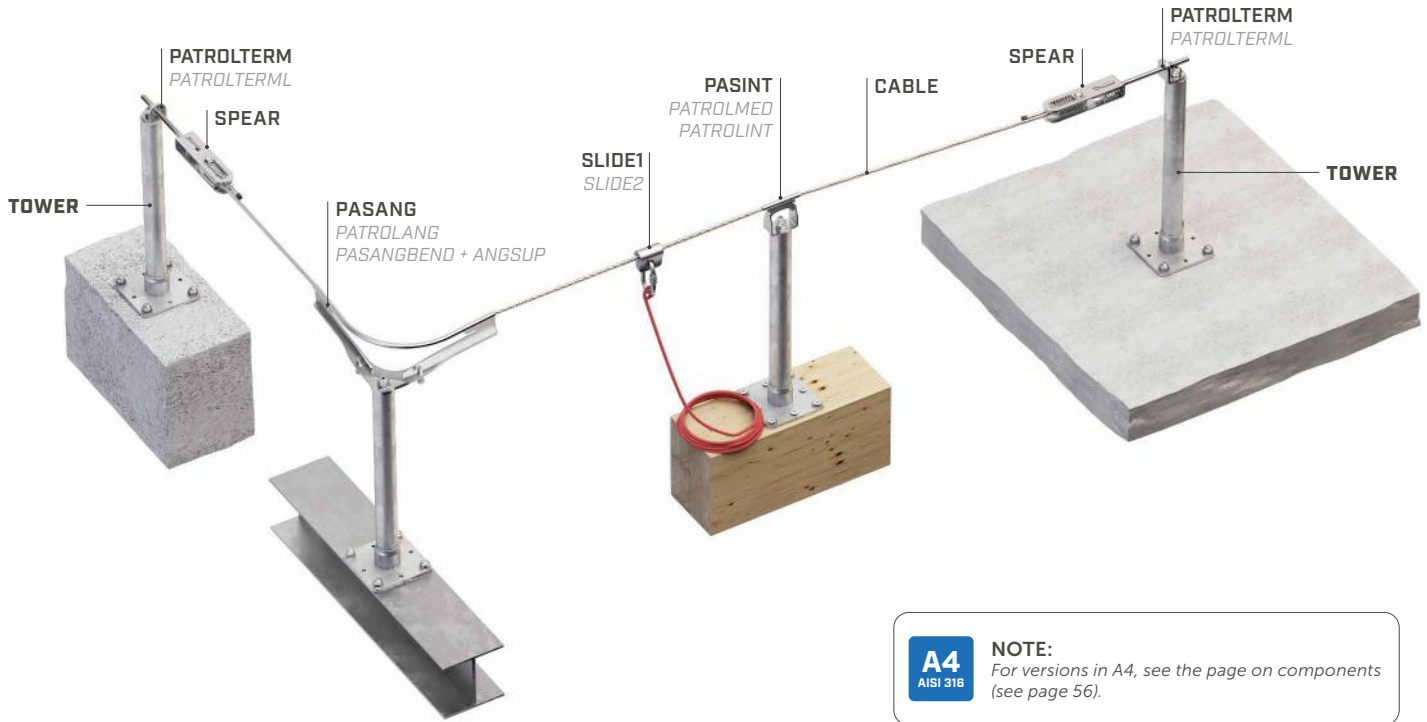

A4
AISI 316

NOTE:
For versions in A4, see the page on components (see page 56).

TECHNICAL DATA*

substructure	minimum thickness	fasteners
GL24h	160 mm	VGS (EVO) Ø9 ULS Ø10
CLT	200 mm	VGS (EVO) Ø9 ULS Ø10
S235JR	6 mm	DIN 933 M12 DIN 125-1A M12 MUT AI 985 M12

substructure	minimum thickness	fasteners
C20/25	140 mm	AB1 M12 SKR Ø12 INA 5.8 M12 VIN-FIX HYB-FIX

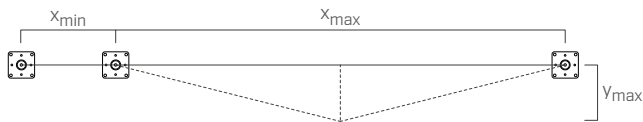

SPEAR			
users	no.		
minimum span	X_{min} [m]	2	2
maximum span	X_{max} [m]	15	15
maximum deflection	Y_{max} [m]	3,60	3,60

* The values indicated are the result of experimental tests carried out under the supervision of third parties in accordance with the standard referred to. For a correct calculation report with minimum distances according to the standard requirements, the substructure must be checked by a qualified engineer before installation.

TOWER | CODES AND DIMENSIONS

CODE	material	d_1		B		H		L		pcs
		[mm]	[in]	[mm]	[in]	[mm]	[in]	[mm]	[in]	
TOWER300	S235JR zinc plated steel	48	1.89	150	6	300	11 3/4	150	6	1
TOWER400		48	1.89	150	6	400	15 3/4	150	6	1
TOWER500		48	1.89	150	6	500	19 3/4	150	6	1
TOWER600		48	1.89	150	6	600	23 5/8	150	6	1
TOWER700		48	1.89	150	6	700	27 1/2	150	6	1
TOWER800		48	1.89	150	6	800	31 1/2	150	6	1
TOWER22500		48	1.89	150	6	500	19 3/4	150	6	1

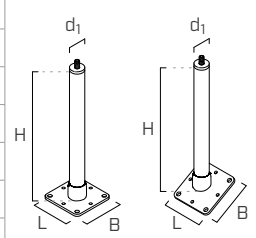

For related TOWERPEAK, TOWERSLOPE, TOWLATEVO and TOPLATE products, see page 250.

PATROL + TOWER A2

LIFELINE ON STAINLESS STEEL SUPPORT
FOR TIMBER, CONCRETE AND STEEL ROOFS

DURABLE

A2 stainless steel support that guarantees excellent resistance and durability in corrosive environments.

MINIMALIST DESIGN

Product that meets high aesthetic and functional requirements.

EFFECTIVE

Controlled deformation device to reduce the load on the fastening systems and structure.

EN 795:2012 C	CEN/TS 16415:2013	UNI 11578:2015 C	AS/NZS 1891.2:2001	AS/NZS 1891.4:2009
---------------------	----------------------	------------------------	-----------------------	-----------------------



MAXIMUM NUMBER
OF USERS



LOAD DIRECTION



TYPES OF
APPLICATION

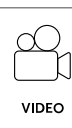
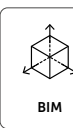

PATROL LIFELINE COMPONENTS

A4
AISI 316

NOTE:

For versions in A4, see the page on components (see page 56).

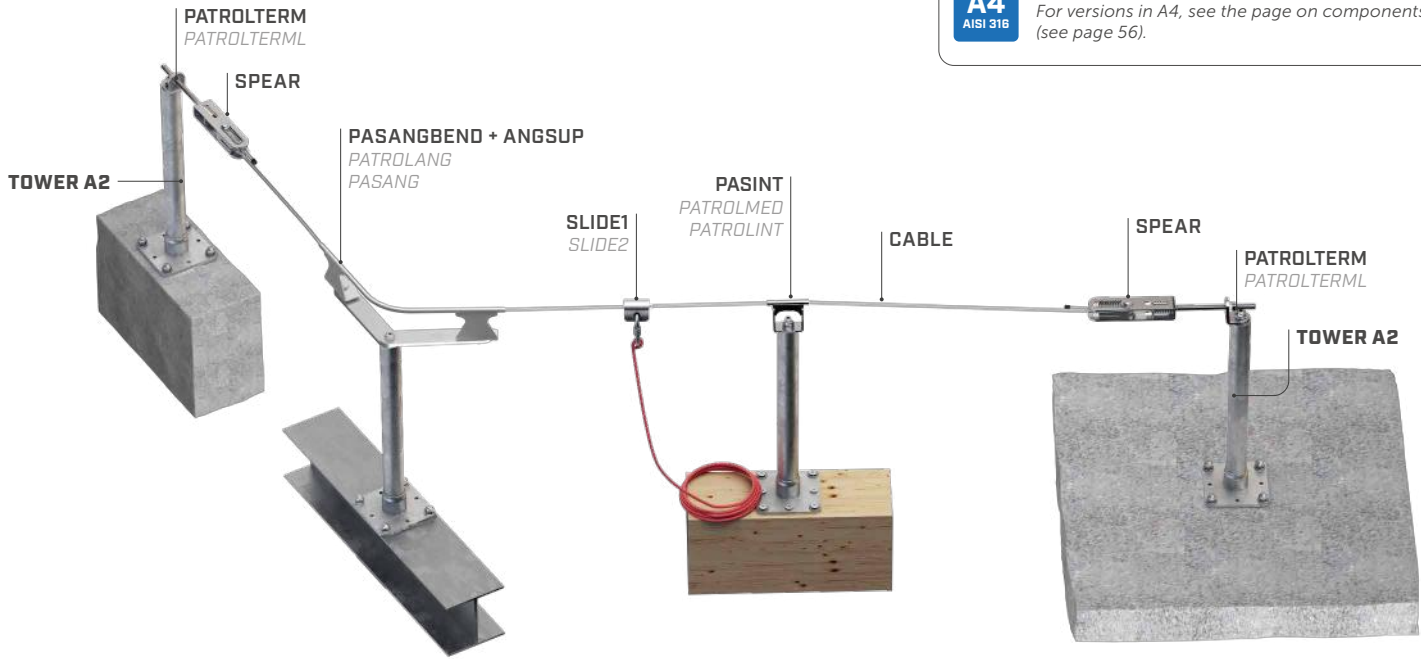

TECHNICAL DATA*

substructure	minimum thickness	fasteners
GL24h	160 mm	VGS (EVO) Ø9 ULS Ø10
CLT	200 mm	VGS (EVO) Ø9 ULS Ø10
S235JR	6 mm	DIN 933 M12 DIN 125-1A M12 MUT A1 985 M12

substructure	minimum thickness	fasteners
C20/25	140 mm	AB1 M12 SKR Ø12 INA 5.8 M12 VIN-FIX HYB-FIX

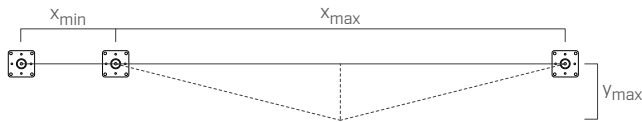

SPEAR			
users	no.		
minimum span	x_{min} [m]	2	2
maximum span	x_{max} [m]	15	15
maximum deflection	y_{max} [m]	3,60	3,60

* The values indicated are the result of experimental tests carried out under the supervision of third parties in accordance with the standard referred to. For a correct calculation report with minimum distances according to the standard requirements, the substructure must be checked by a qualified engineer before installation.

TOWER A2 | CODES AND DIMENSIONS

CODE	material	d_1 [mm] [in]	B [mm] [in]	H [mm] [in]	L [mm] [in]	pcs
TOWERA2300		48 1.89	150 6	300 11 3/4	150 6	1
TOWERA2400	AISI 304 stainless steel grade 1.4301	48 1.89	150 6	400 15 3/4	150 6	1
TOWERA2500		48 1.89	150 6	500 19 3/4	150 6	1

A2
AISI 304

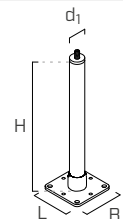

For related TOWERPEAK, TOWERSLOPE, TOWLATEVO and TOPLATE products, see page 250.

PATROL + TOWER XL

LIFELINE ON SUPPORT WITH INCREASED BOTTOM PLATE FOR TIMBER, STEEL AND CONCRETE ROOFS

VERSATILE

Compatible with different types of structures thanks to tested fastenings.

ADAPTABLE

Adjustable support height between 300 and 800 mm to adapt to different roofing thicknesses.

SAFE

The increased bottom plate distributes the actions arising from the anchoring devices over a larger area.

EN 795:2012 C
CEN/TS 18419:2013
UNI 11578:2015 C

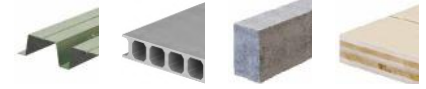

MAXIMUM NUMBER OF USERS



LOAD DIRECTION



TYPES OF APPLICATION

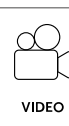
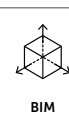

PATROL LIFELINE COMPONENTS

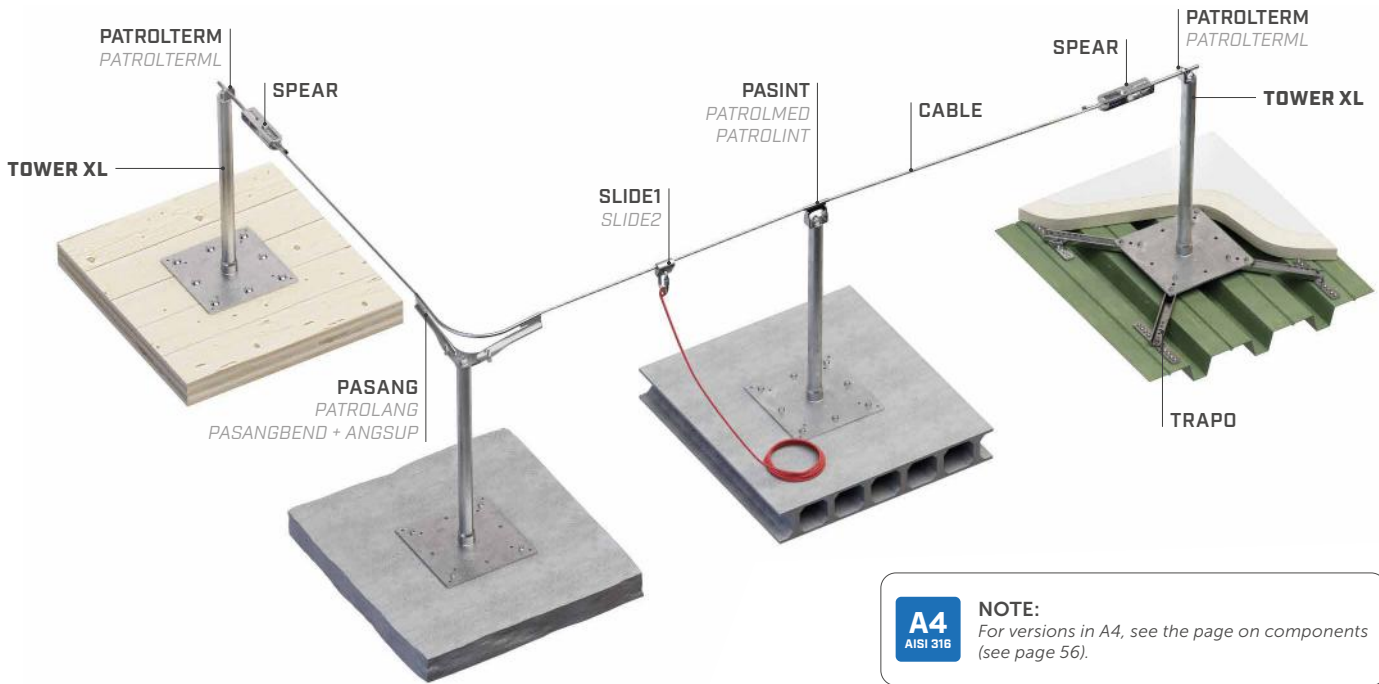

A4
AISI 316

NOTE:

For versions in A4, see the page on components (see page 56).

TECHNICAL DATA*

substructure	minimum thickness	fasteners
CLT	100 mm	VGS (EVO) Ø11 HUS Ø10
C20/25	110 mm	AB7 M10 SKR Ø10 INA 5.8 M10 VIN - FIX

substructure	minimum thickness	fasteners
C45/55	30 mm	BEF TOWERXL1 Ø10
	0,75 mm	TRAPO SET

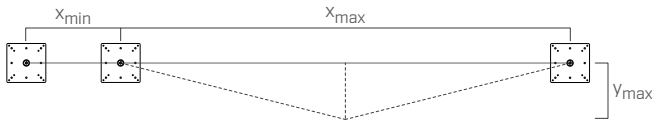

SPEAR



users	no.	
minimum span	x_{min}	[m]
maximum span	x_{max}	[m]
maximum deflection	y_{max}	[m]

* The values indicated are the result of experimental tests carried out under the supervision of third parties in accordance with the standard referred to. For a correct calculation report with minimum distances according to the standard requirements, the substructure must be checked by a qualified engineer before installation.

TOWER XL | CODES AND DIMENSIONS

CODE	material	d_1		B		H		L		pcs
		[mm]	[in]	[mm]	[in]	[mm]	[in]	[mm]	[in]	
TOWERXL300	S235JR zinc plated steel	48	1.89	350	13 3/4	300	11 3/4	350	13 3/4	1
TOWERXL400		48	1.89	350	13 3/4	400	15 3/4	350	13 3/4	1
TOWERXL500		48	1.89	350	13 3/4	500	19 3/4	350	13 3/4	1
TOWERXL600		48	1.89	350	13 3/4	600	23 5/8	350	13 3/4	1
TOWERXL700		48	1.89	350	13 3/4	700	27 1/2	350	13 3/4	1
TOWERXL800		48	1.89	350	13 3/4	800	31 1/2	350	13 3/4	1
TOWERXL1000		48	1.89	350	13 3/4	1000	39 3/8	350	13 3/4	1

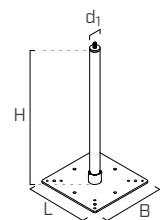

For related BEFTOWERXL, TRAPPO, MANEPDM, MANLEAD, MAN50, MANPOST1, MANPOST2, TOPLATE 2.0 products, see page 250.

PATROL + SOLID

LIFELINE ON RIGID SUPPORT FOR ROPE ACCESS WORK

DESIGNED FOR ROPE ACCESS WORK

The high-rigidity and high-strength support, combined with the jaw-plate anchor system, enables comfortable and safe rope access work.

LIGHT

The aluminium alloy of the support facilitates handling and installation thanks to the lightweight components.

ADAPTABLE

Support height between 400 and 1000 mm to adapt to different roofing thicknesses.

EN 795:2012 C	CEN/TS 18415:2013	UNI 11578:2015 C	AS/NZS 1891.4:2009	AS/NZS 1891.2:2001	BS 8610:2017 A3/A5	AS/NZS 5532:2013
---------------	-------------------	------------------	--------------------	--------------------	--------------------	------------------

ANSI* Z359.18 -2017 A

*The system has been developed and tested in accordance with the static, dynamic and residual strength requirements outlined in the relative ANSI standard.



MAXIMUM NUMBER OF USERS



LOAD DIRECTION



TYPES OF APPLICATION



PATROL LIFELINE COMPONENTS

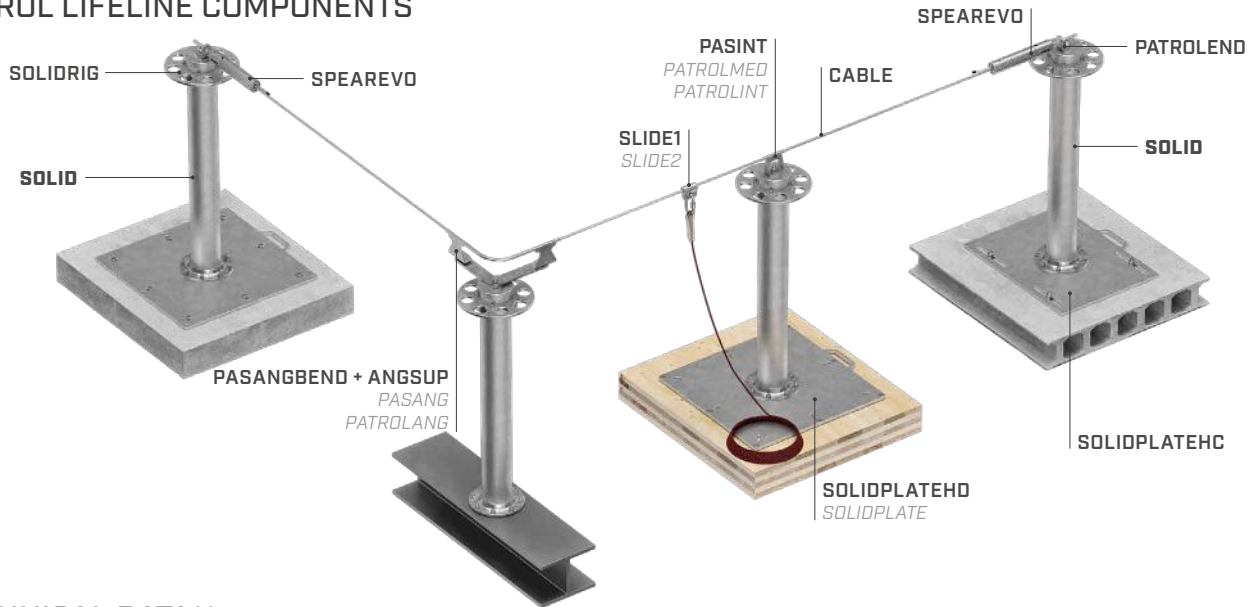

TECHNICAL DATA**

substructure	minimum thickness	fasteners
CLT	160 mm	VGS (EVO) Ø13 HUS12
C20/25	-	INA Ø16 8.8
S235	15 mm	bolt or rod M12 10.9

substructure	minimum thickness	fasteners
C20/25	140 mm	AB1 Ø12
		SKR (EVO) Ø12
		INA Ø12 8.8 VIN-FIX

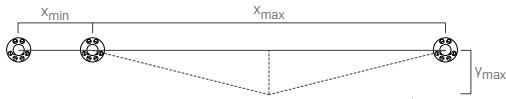

		SPEAREVO				SOLIDRIG		
		EN 795:2012 C	DEN/TS 18415:2013	UNI 11578:2015 C	AS/NZS 1891.4:2009	AS/NZS 1891.2:2001	BS 8810:2017 A3/A5	AS/NZS 5532:2013
users	no.							
work method		fall protection/restraint				suspension		
minimum span	x_{min} [m]	2				-	-	
maximum span	x_{max} [m]	15				-	-	
maximum deflection	y_{max} [m]	3,35				-	-	

**The values indicated are the result of experimental tests carried out under the supervision of third parties in accordance with the standard referred to. For a correct calculation report with minimum distances according to the standard requirements, the substructure must be checked by a qualified engineer before installation.

SOLID | CODES AND DIMENSIONS

CODE	description	material	d_1 [mm] [in]	B [mm] [in]	L [mm] [in]	H [mm] [in]	pcs	
SOLID400	rigid support for rope access work	EN AW-6082-T6	120 4.73	220,5 8 11/16	-	400 15 3/4	1	
SOLID600			120 4.73	220,5 8 11/16	-	600 23 5/8	1	
SOLID800			120 4.73	220,5 8 11/16	-	800 31 1/2	1	
SOLID1000			120 4.73	220,5 8 11/16	-	1000 39 3/8	1	
SOLIDRIG	jaw system for rope access work	EN AW-6082-T6	300 11.82	-	-	-	1	
SOLIDPLATE	bottom plate for timber and concrete	EN AW-6082-T6	-	550 21 5/8	595 23 7/16	-	1	
SOLIDPLATEHD	bottom plate for timber and concrete for heavy-duty applications	EN AW-6082-T6	-	650 25 9/16	695 27 3/8	-	1	
SOLIDPLATEHC	bottom plate and counterplate for aerated concrete	EN AW-6082-T6	-	650 25 9/16	545 21 7/16	-	1	

PATROL + T-CLAMP

LIFELINE ON SUPPORT FOR CONTINUOUS ROOFS

VERSATILE

A versatile system with special clamps allowing installation on various types of metal roofs.

ADAPTABLE

The universal plates, available in various sizes, guarantee a solution for the different spans between the seams.

MODULAR

The optional post allows the anchor point to be raised, thus overcoming obstacles on the roof.

EN 795:2012 C	CEN/TS 18415:2013	UNI 11578:2015 C	AS/NZS 1891.4:2009	AS/NZS 1891.2:2001
---------------------	----------------------	------------------------	-----------------------	-----------------------



MAXIMUM NUMBER
OF USERS



LOAD DIRECTION



TYPES OF
APPLICATION



PATROL LIFELINE COMPONENTS

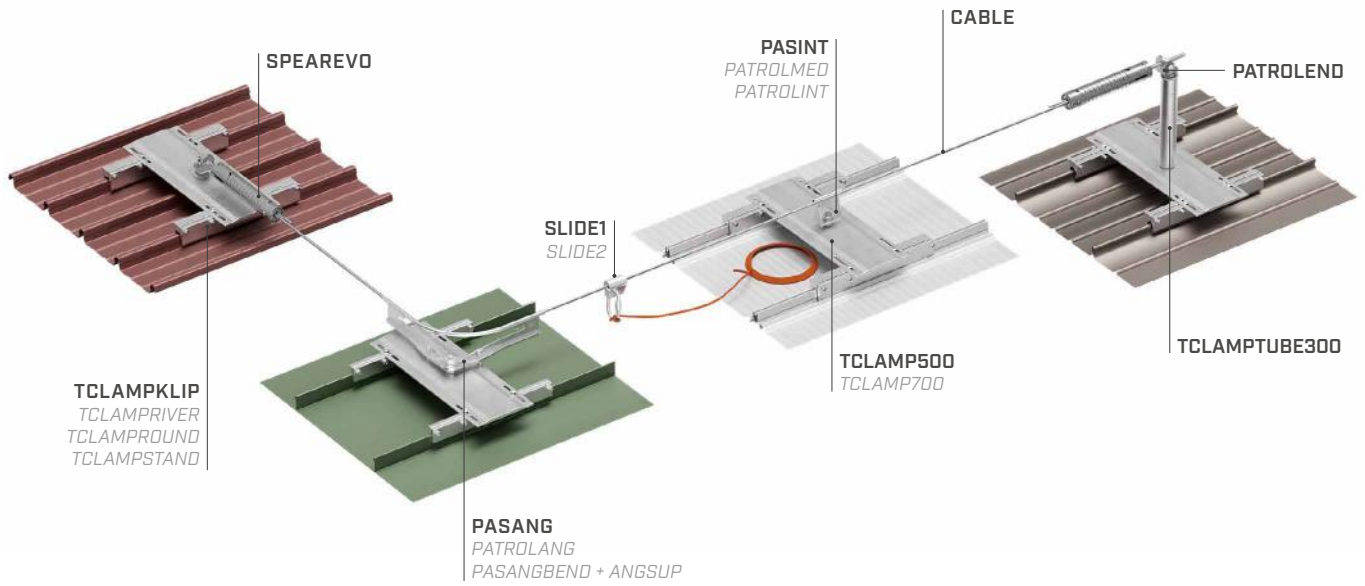

T-CLAMP | CODES AND DIMENSIONS

CODE	description	material	B [mm] [in]	H [mm] [in]	L [mm] [in]	pcs	
TCLAMP500	universal plate for small and medium spans between seams	EN AW-6082-T6	190 7 1/2	- -	515 20 1/4	1	
TCLAMP700	universal plate for large spans between seams	EN AW-6082-T6	190 7 1/2	- -	760 29 15/16	1	
TCLAMPPTUBE300	optional spacer to overcome obstacles	EN AW-6060-T6/ AISI 304	50 1 15/16	300 11 3/4	- -	1	
TCLAMPKLIP	fastening clamps set for Klip-Lok type roofs	EN AW-6060-T6	- -	- -	- -	1	
TCLAMPPRIVER	fastening clamps set for Riverclack type roofs	EN AW-6060-T6	- -	- -	- -	1	
TCLAMPROUND	fastening clamps set for round standing seam roofs	EN AW-6060-T6	- -	- -	- -	1	-
TCLAMPSTAND	fastening clamps set for standing seam roofs	EN AW-6060-T6	- -	- -	- -	1	

PATROL + SHIELD | SHIELD 2

LIFELINE ON SUPPORT FOR TRAPEZOIDAL METAL ROOFS WITH AND WITHOUT INSULATION LAYER

COMPLETE

The package includes fasteners and cellular rubber gaskets, to ensure waterproofing.

VERSATILE

Used on all trapezoidal metal roofs with and without insulation layer with a span between frets of up to 420 mm.

FUNCTIONAL

SHIELD can be used as a start, end or corner lifeline; SHIELD 2 is ideal as a straight intermediate point.

EN 795:2012 C	CEN/TS 18415:2013	UNI 11578:2015 C	AS/NZS 1891.2:2001	AS/NZS 1891.4:2009
---------------	-------------------	------------------	--------------------	--------------------



MAXIMUM NUMBER OF USERS



LOAD DIRECTION





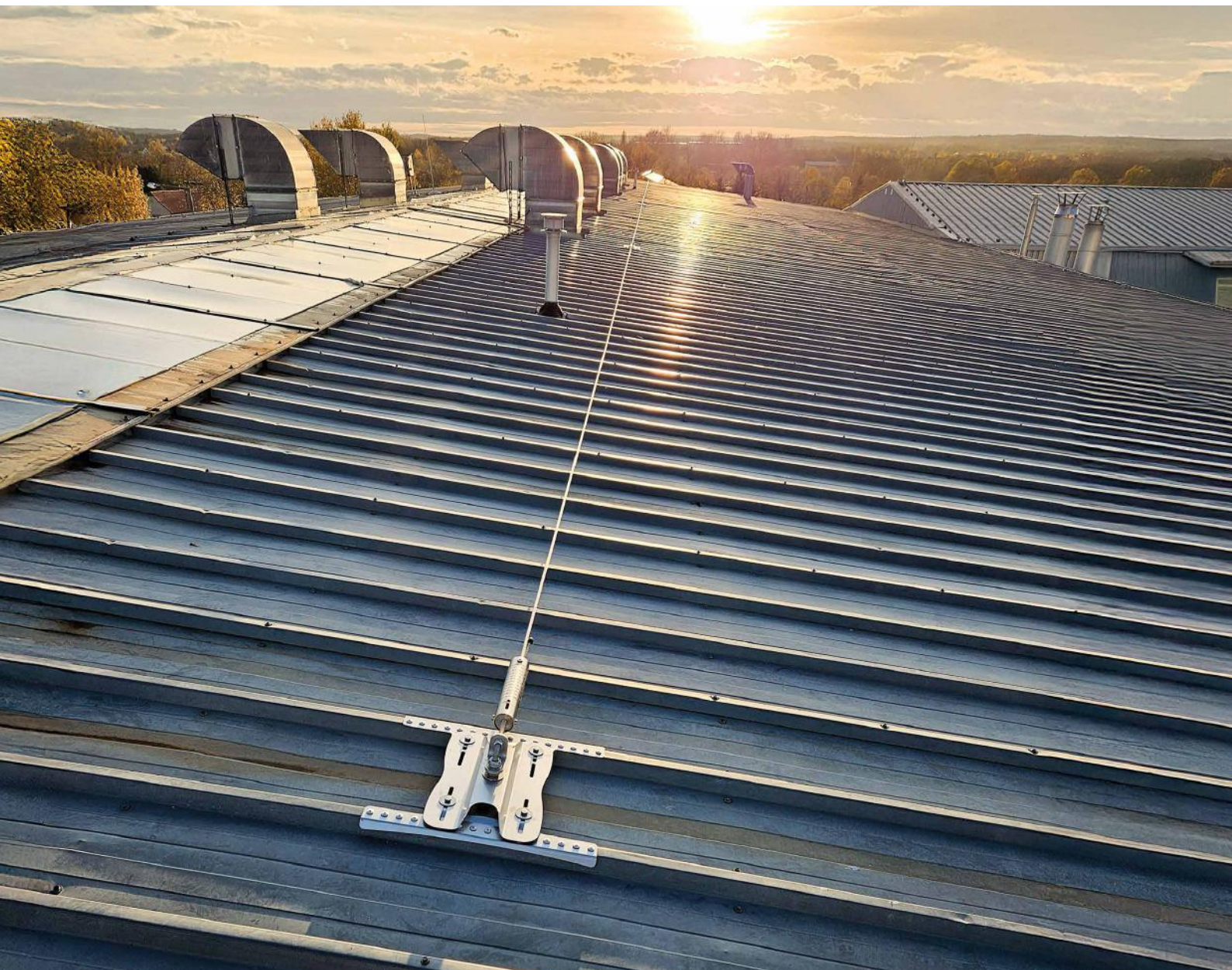
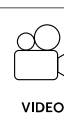

TYPES OF APPLICATION

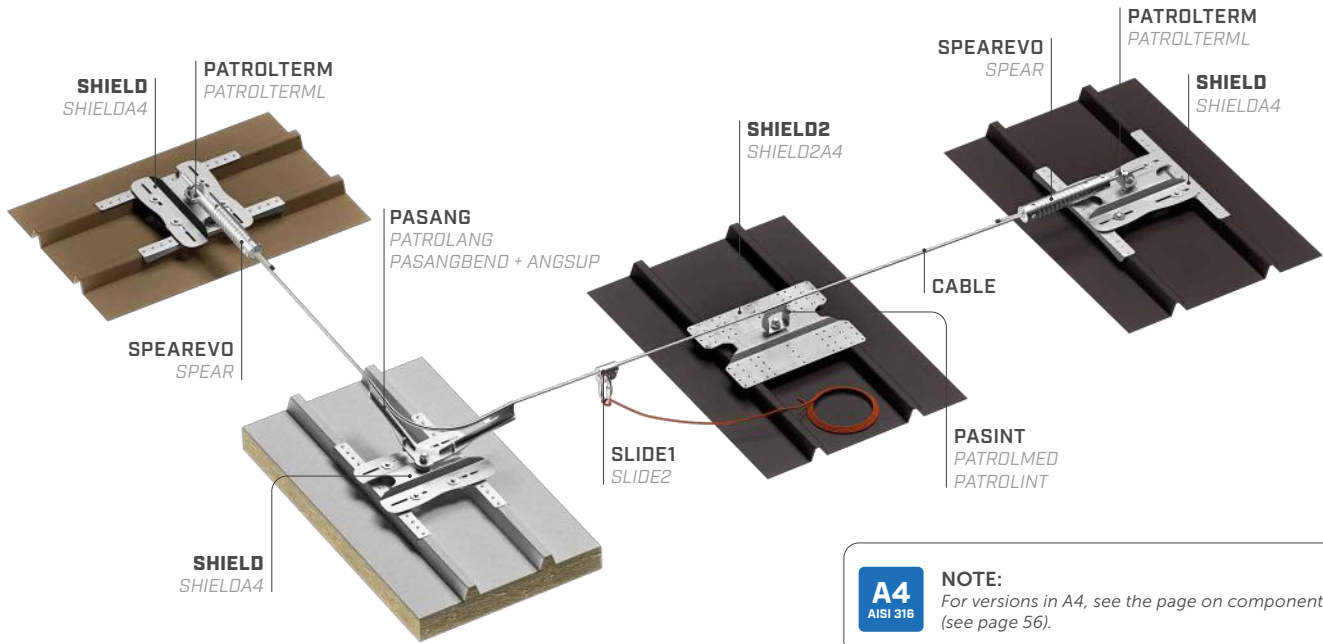

PATROL LIFELINE COMPONENTS



TECHNICAL DATA*

substructure	minimum thickness	fastening systems included
 Fe	0,5 mm	SHIELD: rivet 6,3 x 20,2 mm with EPDM washer (x 32) SHIELD2: rivet 6,3 x 20,2 mm with EPDM washer (x 16)
 Fe	0,5 mm	
 Al	1 mm	
 Al	1 mm	

		SPEAR				SPEAREVO					
		EN 795:2012 C	CEN/TS 16415:2013	UNI 11578:2015 C	AS/NZS 1891.2:2001	AS/NZS 1891.4:2009	EN 795:2012 C	CEN/TS 16415:2013	UNI 11578:2015 C	AS/NZS 1891.2:2001	AS/NZS 1891.4:2009
users	no.	👤👤		👤👤		👤👤👤👤				👤👤👤👤	
minimum span	x_{min} [m]	2		2		2				2	
maximum span	x_{max} [m]	7,5		7,5		15				15	
maximum deflection	y_{max} [m]	1,44		1,44		3,40				3,40	

* The values indicated are the result of experimental tests carried out under the supervision of third parties in accordance with the standard referred to. For a correct calculation report with minimum distances according to the standard requirements, the substructure must be checked by a qualified engineer before installation.

SHIELD - SHIELD 2 | CODES AND DIMENSIONS

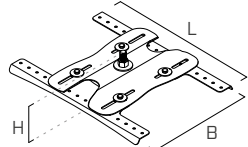
CODE	description	material		B [mm] [in]	H [mm] [in]	L [mm] [in]	pcs	
SHIELD	lifeline support	AISI 304 stainless steel grade 1.4301	A2 AISI 304	180-420 7 1/8-16 9/16	85 3 3/8	476 18 3/4	1	
SHIELDA4	lifeline support	AISI 316 stainless steel grade 1.4401	A4 AISI 316					

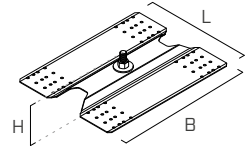
CODE	description	material		B [mm] [in]	H [mm] [in]	L [mm] [in]	pcs	
SHIELD2	intermediate lifeline support	AISI 304 stainless steel grade 1.4301	A2 AISI 304	250 - 370 10-14 9/16	65 2 9/16	322 12 11/16	1	
SHIELD2A4	intermediate lifeline support	AISI 316 stainless steel grade 1.4401	A4 AISI 316					

PATROL + WAVE

LIFELINE ON SUPPORT FOR CORRUGATED SHEET METAL ROOFS

SIMPLE

Simple and quick installation, thanks to the shape obtained with a single plate.

COMPLETE

The package includes fasteners and cellular rubber gaskets, to ensure waterproofing.

FUNCTIONAL

WAVE can be used as either an end, intermediate or angular support for lifeline systems.

EN 795:2012 C	CEN/TS 18419:2013	UNI 11578:2015 C
---------------------	----------------------	------------------------



MAXIMUM NUMBER OF USERS



LOAD DIRECTION



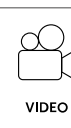
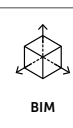

TYPES OF APPLICATION



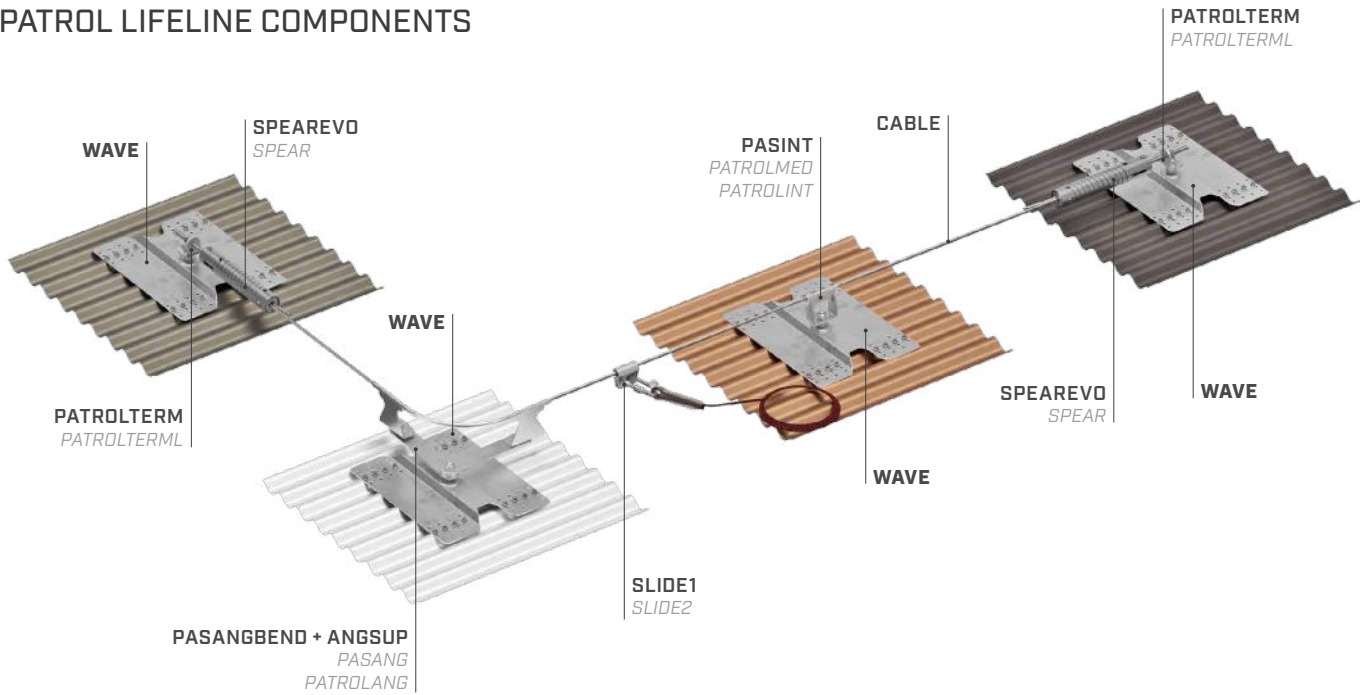



PATROL LIFELINE COMPONENTS

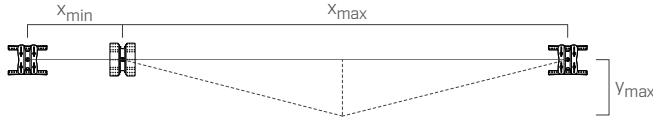

TECHNICAL DATA*

substructure	minimum thickness	fastening systems included
 Fe	0,63 mm	self-drilling screws 5,5 x 25 mm A2 with EPDM washer (x16) 4 EPDM gaskets 

Wave pitch: 76 mm.

			SPEAREVO
			  
users		no.	
minimum span	x_{min}	[m]	2
maximum span	x_{max}	[m]	15
maximum deflection	y_{max}	[m]	3,40

* The values indicated are the result of experimental tests carried out under the supervision of third parties in accordance with the standard referred to. For a correct calculation report with minimum distances according to the standard requirements, the substructure must be checked by a qualified engineer before installation.

WAVE | CODES AND DIMENSIONS

CODE	description	material		B [mm] [in]	H [mm] [in]	L [mm] [in]	pcs
WAVE	support for corrugated sheet metal	AISI 304 stainless steel grade 1.4301		420 16 9/16	65 2 9/16	322 12 11/16	1

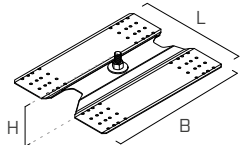

PATROL + COPPO

LIFELINE ON SUPPORT FOR ROOFS WITH FAUX TILES

COMPLETE

The package includes fasteners and cellular rubber gaskets, to ensure roof waterproofing.

ADAPTABLE

Pre-drilled plate with holes at different distances to suit various types of sheet metal.

FAST

Quick assembly upon the completion of roofing with just a few tools.

EN
795:2012
C

CEN/TS
18415:2013

UNI
11578:2015
C



MAXIMUM NUMBER
OF USERS



LOAD DIRECTION



TYPES OF
APPLICATION

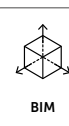

PATROL LIFELINE COMPONENTS

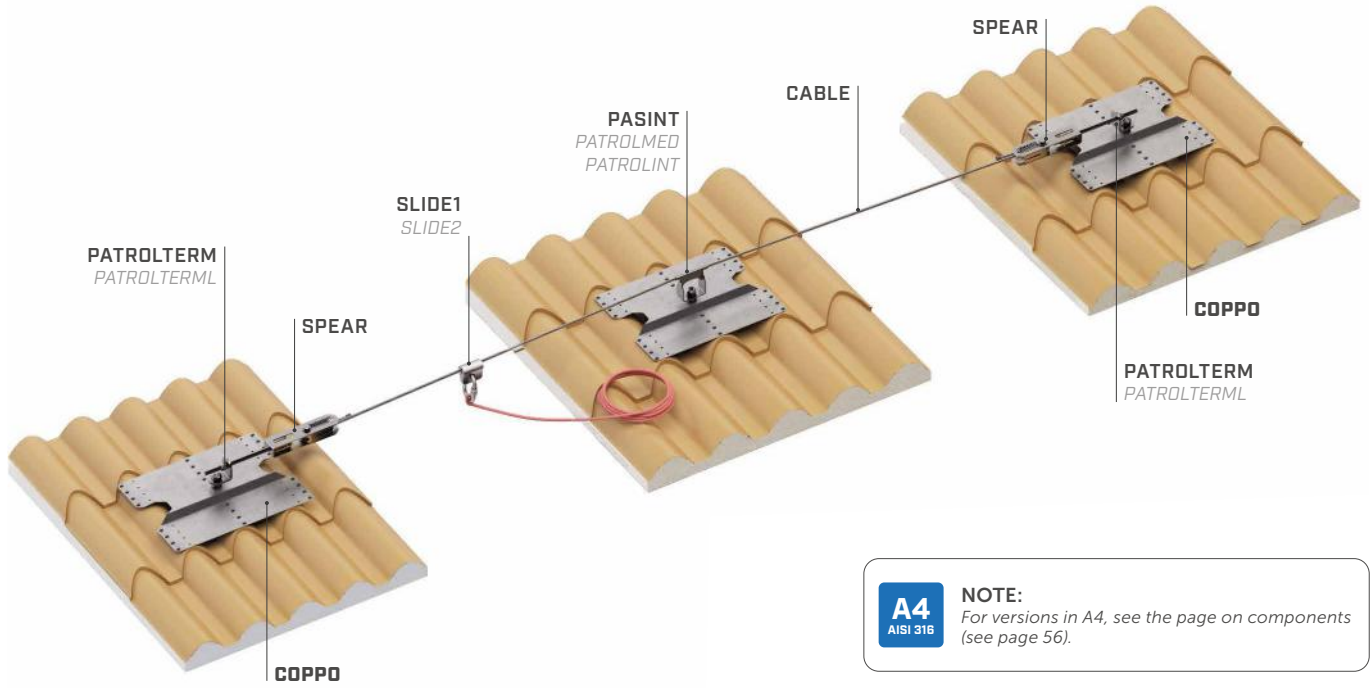

A4
AISI 316

NOTE:
For versions in A4, see the page on components (see page 56).

TECHNICAL DATA*

substructure	minimum thickness	fastening systems included
Fe	0,5 mm	rivet 6,3 x 20,2 mm with EPDM washer (x 24)
Al	0,7 mm	

			SPEAR
users		no.	
minimum span	X_{min}	[m]	2
maximum span	X_{max}	[m]	7,5
maximum deflection	Y_{max}	[m]	1,44

* The values indicated are the result of experimental tests carried out under the supervision of third parties in accordance with the standard referred to. For a correct calculation report with minimum distances according to the standard requirements, the substructure must be checked by a qualified engineer before installation.

COPPO | CODES AND DIMENSIONS

CODE	description	material		B [mm] [in]	H [mm] [in]	L [mm] [in]	pcs	
COPPO	support for faux tile roofing panel	AISI 304 stainless steel grade 1.4301		166 - 200 6 9/16-8	65 2 9/16	322 12 11/16	1	

PATROL + T-ROOF

LIFELINE ON SUPPORT FOR PVC/TPO AND BITUMINOUS ROOFS

WATERPROOF

The TROOFWPLATE plate ensures complete waterproofing for flat and even slightly inclined roofs. The package includes fasteners and cellular rubber gaskets, to ensure roof waterproofing.

ADAPTABLE

The various fastening kits enable specific installation for each substructure and for different insulation thicknesses.

UNIVERSAL

Universal system for application on the roof surface with installation on various supporting substructures.

EN 795:2012 C

CEN/TS 18418:2013

UNI 11578:2015 C



MAXIMUM NUMBER OF USERS



LOAD DIRECTION



TYPES OF APPLICATION

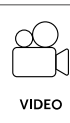
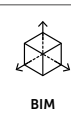

PATROL LIFELINE COMPONENTS

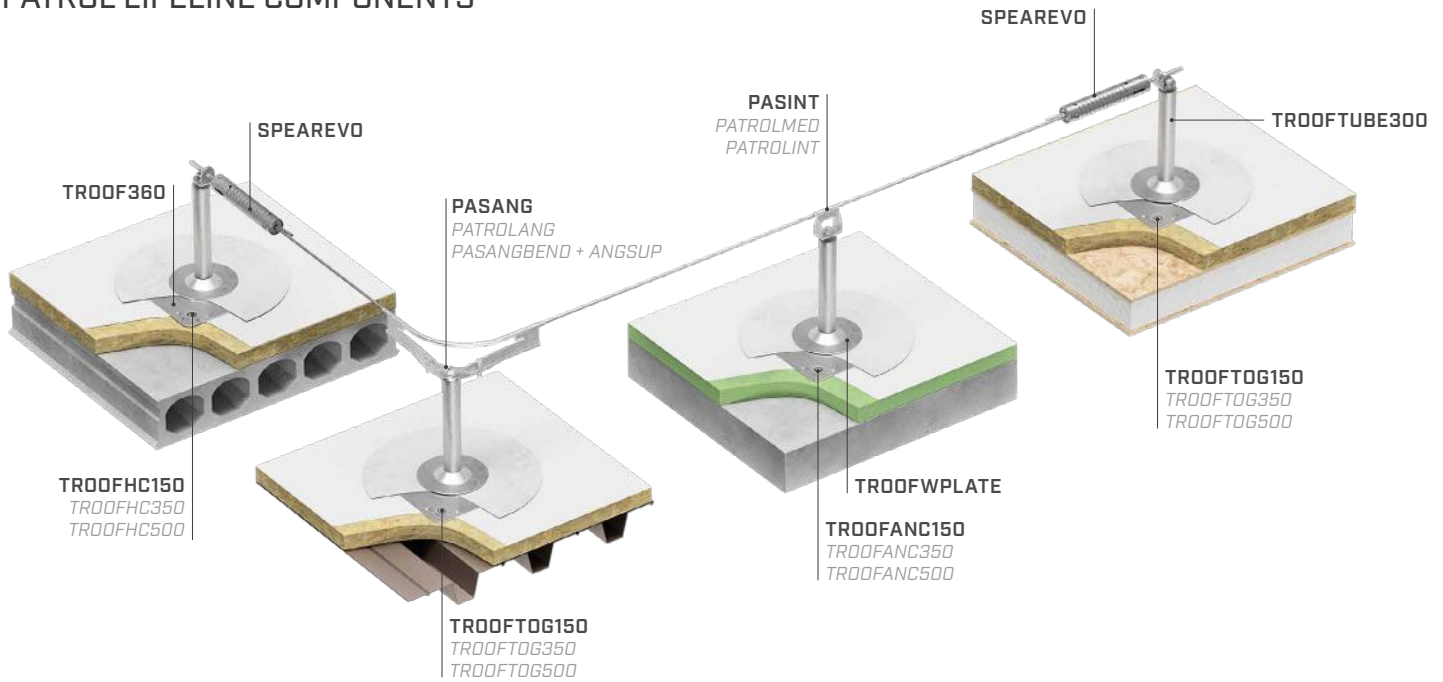

T-ROOF | CODES AND DIMENSIONS

CODE	description	material		B [mm]	H [mm]	L [mm]	s [mm]	pcs
TROOF360	universal plate for installation on the roof surface	AISI 304 stainless steel grade 1.4301	A2 AISI 304	360	-	360	3	1
TROOFWPLATE	waterproofing plate			Ø100	-	-	-	1
TROOFTUBE300	spacer to overcome obstacles	EN AW-6060-T6 AISI 304 stainless steel grade 1.4301	A2 AISI 304 alu 6060	50	300	-	-	1
TROOFTOG150				-	150	-	-	1
TROOFTOG350	toggle bolt kit with cup washer	bright zinc plated carbon steel	S235 HDG	-	350	-	-	1
TROOFTOG500				-	500	-	-	1
TROOFHC150				-	150	-	-	1
TROOFHC350	fastening kit for substructure in aerated concrete	bright zinc plated carbon steel		-	350	-	-	1
TROOFHC500				-	500	-	-	1
TROOFANC150				-	150	-	-	1
TROOFANC350	fastening kit for concrete substructure	bright zinc plated carbon steel		-	350	-	-	1
TROOFANC500				-	500	-	-	1

PATROL + BLOCK

LIFELINE ON SUPPORT WITH BALLAST FOR FLAT ROOFS

WITHOUT DRILLING

It is designed for installation on flat roofs, and does not require to drill the roof covering, avoiding thermal bridging and preserving the waterproofing layer of the structure.

FLAT ROOFS

Designed for flat roofs with inclines up to 5° with PVC, TPO or bituminous final covering, with or without gravel.

SIMPLE

Concrete ballast slabs in standard sizes simplify the installation.

EN 795:2012 C

CEN/TS 18418:2013

UNI 11578:2015 C

PVC

TPO

BYTUM

MAXIMUM NUMBER OF USERS



LOAD DIRECTION



TYPES OF APPLICATION

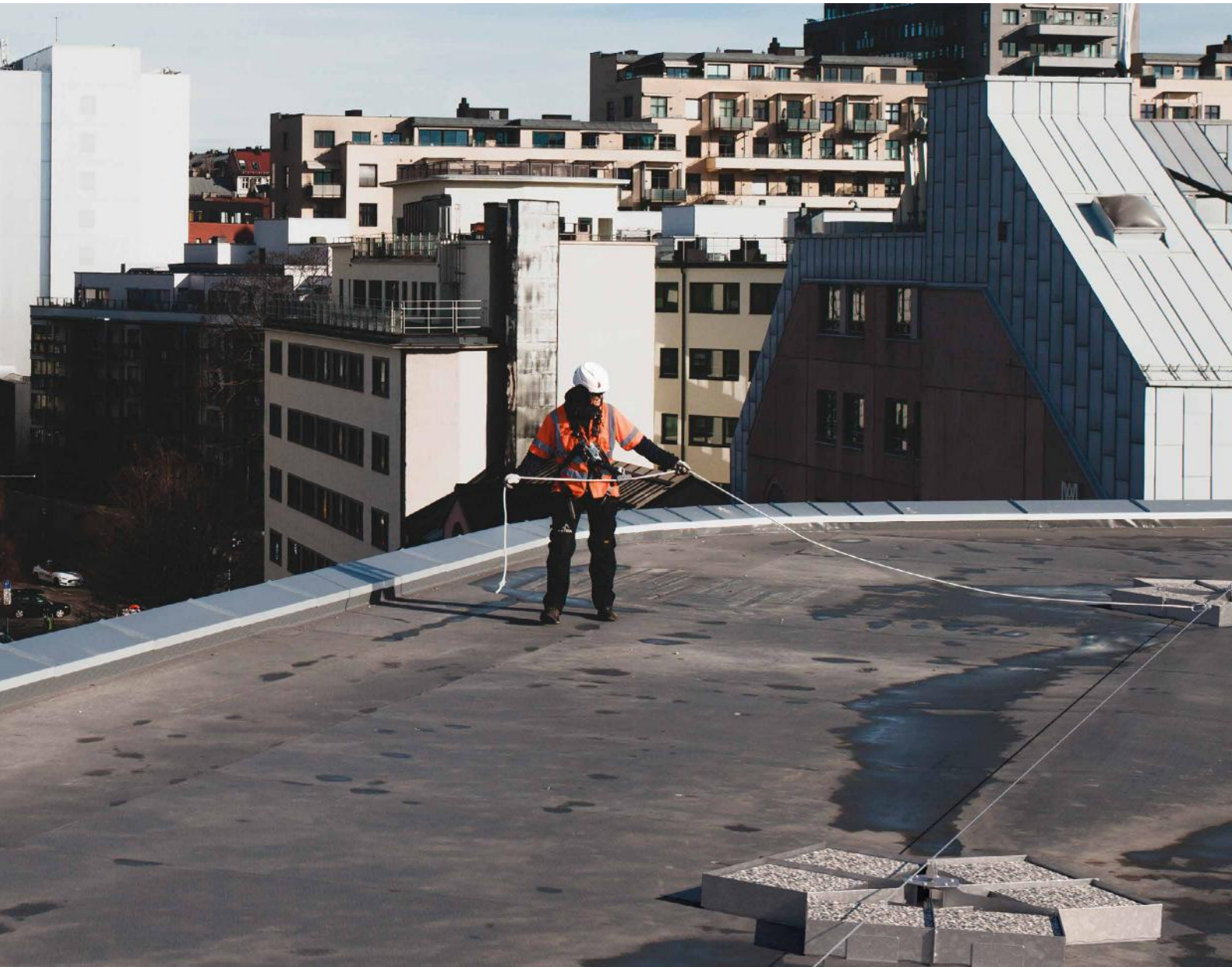

PATROL LIFELINE COMPONENTS

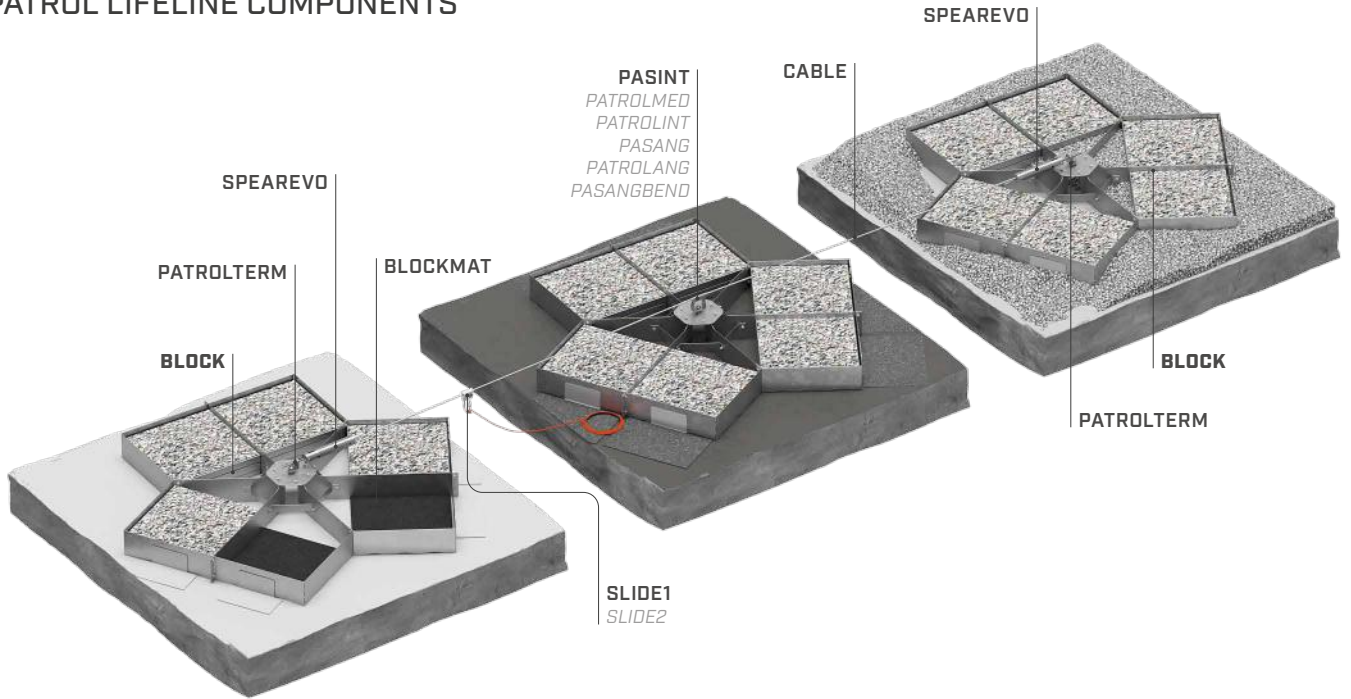

TECHNICAL DATA*

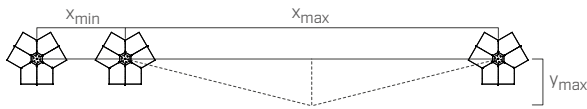

			SPEAREVO		
			EN 795:2012 C	CEN/TS 16415:2013	UNI 11578:2015 C
users	no.		🧑🧑		
minimum span	x_{min}	[m]	2		
maximum span	x_{max}	[m]	10		
maximum deflection	y_{max}	[m]	2		

* The values indicated are the result of experimental tests carried out under the supervision of third parties in accordance with the standard referred to. For a correct calculation report with minimum distances according to the standard requirements, the substructure must be checked by a qualified engineer before installation.

BLOCK | CODES AND DIMENSIONS

CODE	material		B [mm] [in]	H [mm] [in]	L [mm] [in]	pcs	
BLOCK	AISI 304 stainless steel grade 1.4301	A2 AISI 304	1870 73 5/8	165 6 1/2	1645 64 3/4	1	
BLOCKPLATE	AISI 304 stainless steel grade 1.4301	A2 AISI 304	120 4 3/4	120 4 3/4	240 9 7/16	1	
BLOCKMAT							optional
ballast weight							18 bricks x 21,5 kg = 387 kg
total weight							400 kg

COMPLEMENTARY PRODUCTS

CODE	description	B [mm] [in]	L [mm] [in]	s [mm] [in]	pcs	
BLOCKMAT	BLOCKMAT mats not included in the supply of the BLOCK item (3 pieces per BLOCK are required) it can be ordered separately	550 21 5/8	1050 41 5/16	6 0.24	1	

PATROL + PATROLEND

DIRECT FASTENING ON STEEL AND CONCRETE SUBSTRUCTURES

EASY

Quick and easy assembly directly onto concrete or steel structure.

UNIVERSAL

System designed for different applications: flat, façade, overhead.

FUNCTIONAL

Specially designed shuttles can be used to enable the operator to overcome bends and intermediate points without ever becoming disconnected from the system.



CSA Z259.16 READY
Validated through testing



MAXIMUM NUMBER OF USERS



LOAD DIRECTION



TYPES OF APPLICATION



BIM



VIDEO



MANUALS



PATROL LIFELINE COMPONENTS

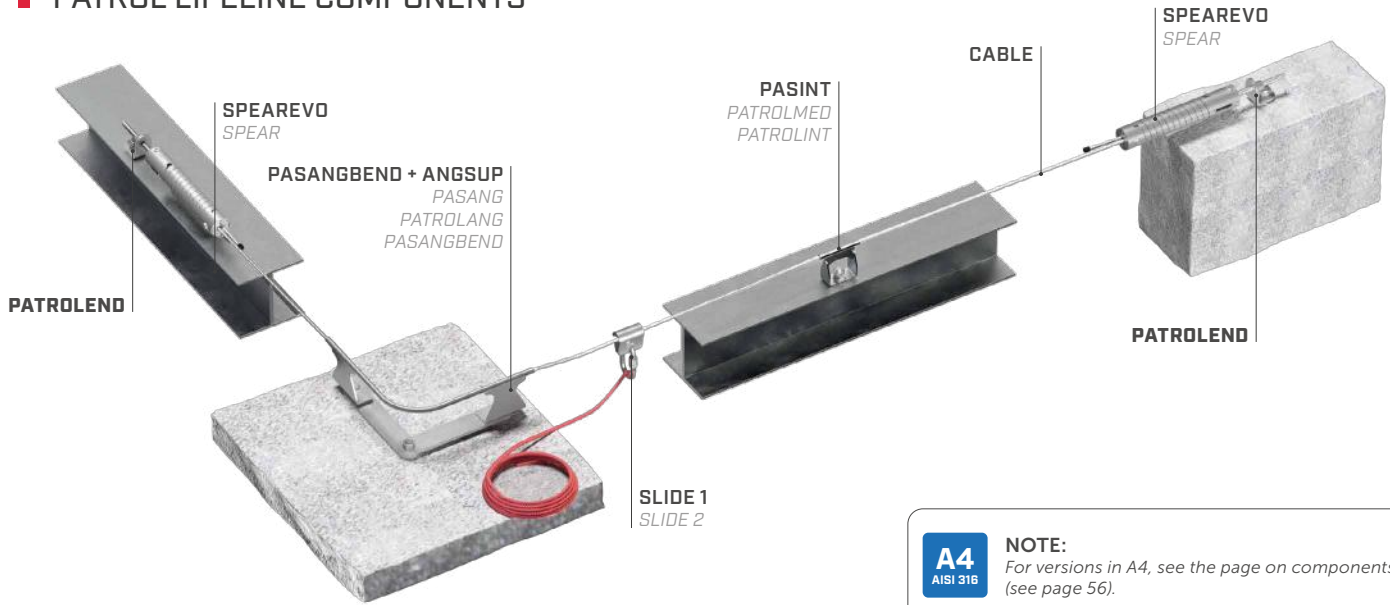

TECHNICAL DATA*

PATROLEND

substructure	minimum thickness	fasteners
C20/25	116 mm	INA 5.8 M16 VIN-FIX
	170 mm	SKR Ø16
	170 mm	AB1 M16

substructure	minimum thickness	fasteners
S235JR	5 mm	DIN 933 M16 DIN 125-1A M16 MUT AI 985 M16

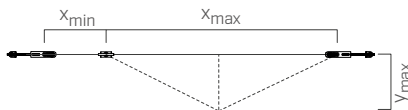

		SPEAR				SPEAREVO				
		EN 795:2012 C	CEI/TS 16415:2013	UNI 11578:2015 C	AS/NZS 1891.2:2001	AS/NZS 1891.4:2009	EN 795:2012 C	CEI/TS 16415:2013	UNI 11578:2015 C	AS/NZS 1891.2:2001
users	no.				(SPAN)					
minimum span	x_{min} [m]	2			2			2		2
maximum span	x_{max} [m]		7,5		7,5			15		15
maximum deflection	y_{max} [m]		1,44		1,44			3,40		3,40

* The values indicated are the result of experimental tests carried out under the supervision of third parties in accordance with the standard referred to. For a correct calculation report with minimum distances according to the standard requirements, the substructure must be checked by a qualified engineer before installation.

PATROLEND | CODES AND DIMENSIONS

CODE	description	material		B [mm] [in]	H [mm] [in]	L [mm] [in]	s [mm] [in]	pcs	
PATROLEND	end element	AISI 304 stainless steel grade 1.4301		40 1 9/16	61 2 3/8	66 2 5/8	6 0.24	1	
PATROLEND A4	A4 end element	AISI 316 stainless steel grade 1.4401		40 1 9/16	61 2 3/8	66 2 5/8	6 0.24	1	

PATROL OVERHEAD

OVERHEAD LIFELINE ON STEEL AND CONCRETE

FUNCTIONAL

Lifeline for aerial applications such as maintenance of coaches, trucks, machinery and aeroplanes.

SAFE

The sliding device allows operators to pass intermediate elements and curves without ever disengaging from the system.

PRACTICAL

Possibility of anchoring to the upside-down TOWER support to lower the lifeline relative to the ceiling.

EN
795:2012
C

CEN/TS
18415:2013

UNI
11578:2015
C

AS/NZS
1891.4:2009

AS/NZS
1891.2:2001

CSA
Z259.16

CSA Z259.16 READY
Validated through testing



MAXIMUM NUMBER
OF USERS



LOAD DIRECTION



TYPES OF
APPLICATION



BIM



VIDEO



MANUALS

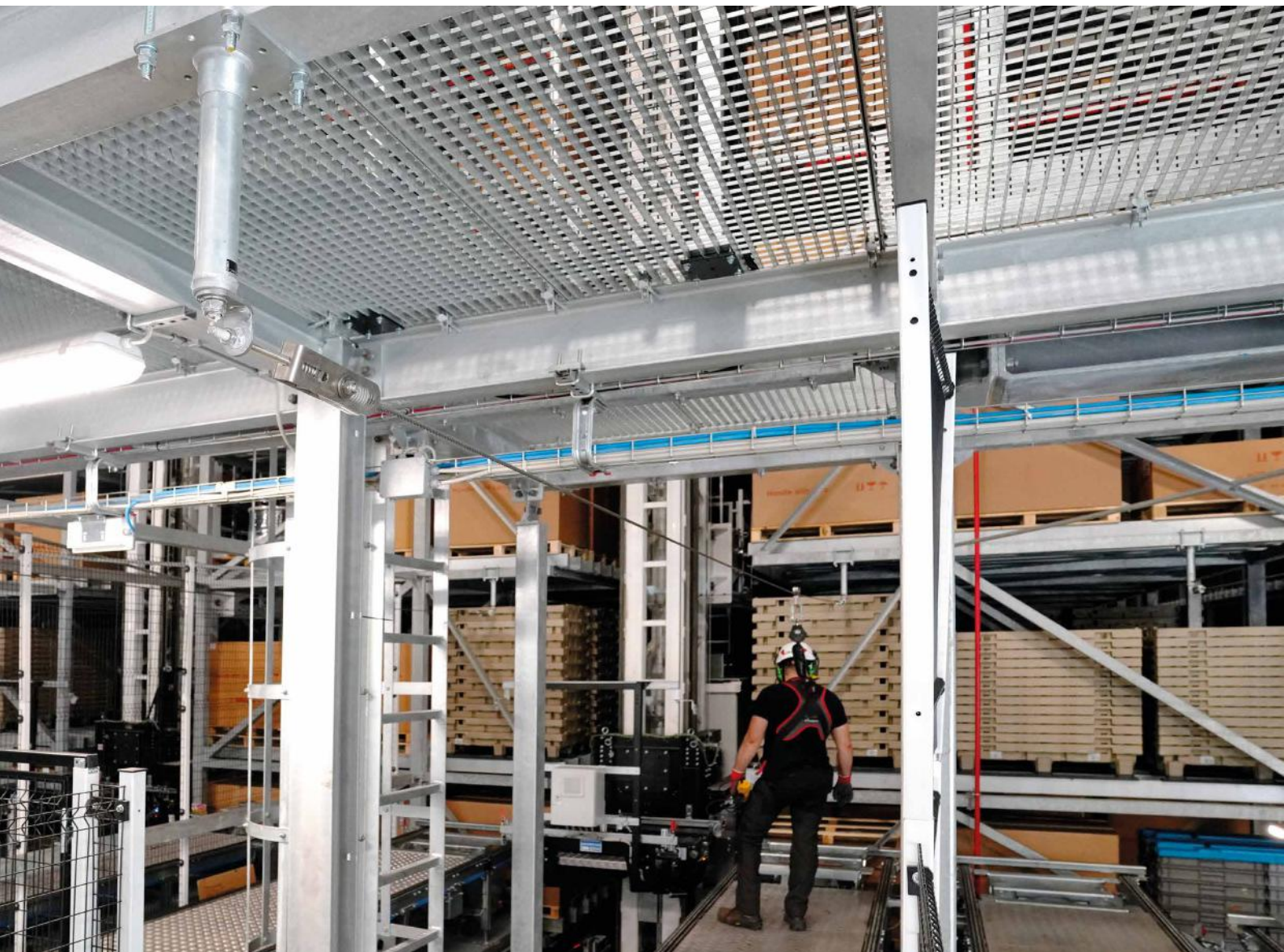

PATROL LIFELINE COMPONENTS

A4
AISI 316

NOTE:

For versions in A4, see the page on components (see page 56).

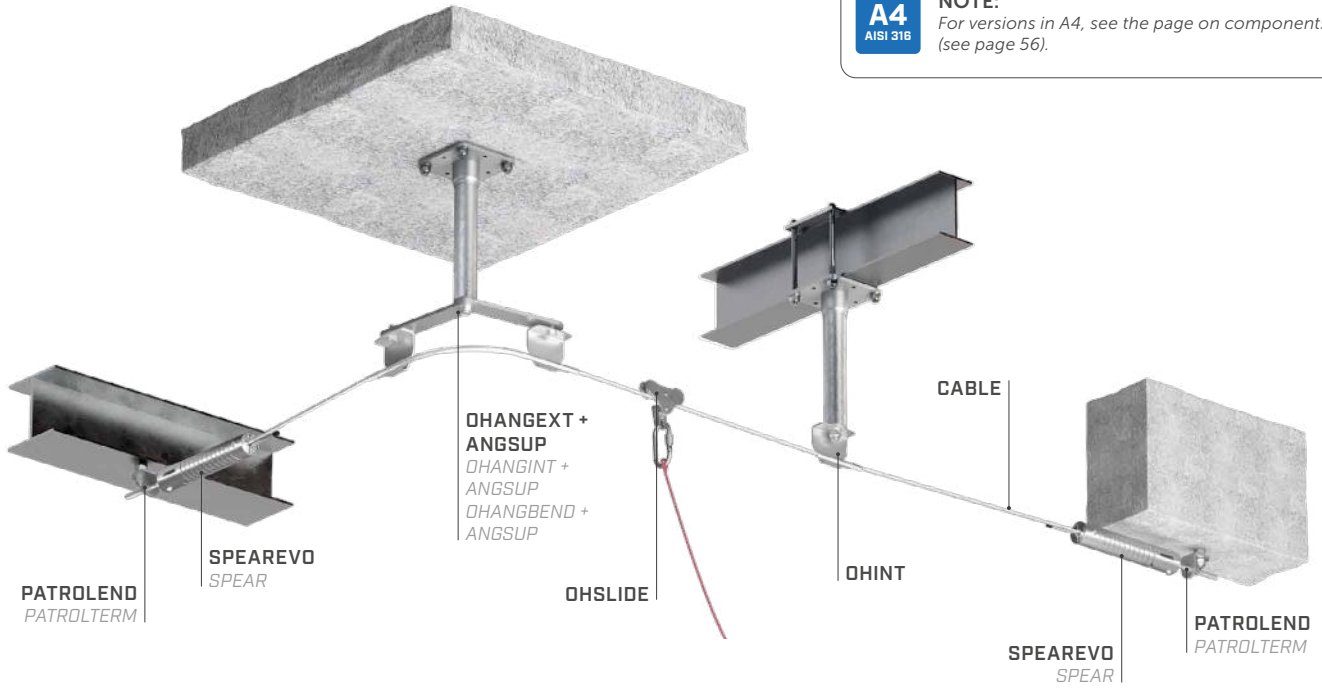

TECHNICAL DATA*

PATROLEND | PATROLTERM

substructure	minimum thickness	fasteners
C20/25	116 mm	INA 5.8 M16 VIN-FIX
	170 mm	SKR Ø16
	170 mm	AB1 M16

substructure	minimum thickness	fasteners
S235JR	5 mm	DIN 933 M16 DIN 125-1A M16 MUT AI 985 M16

* The values indicated are the result of experimental tests carried out under the supervision of third parties in accordance with the standard referred to. For a correct calculation report with minimum distances according to the standard requirements, the substructure must be checked by a qualified engineer before installation.

PATROL + PATROLEND

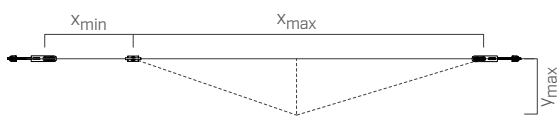

		SPEAR					SPEAREVO				
		EN 795:2012 C	CEN/TS 16415:2013	UNI 11578:2015 C	AS/NZS 1891.2:2001	AS/NZS 1891.4:2009	EN 795:2012 C	CEN/TS 16415:2013	UNI 11578:2015 C	AS/NZS 1891.2:2001	AS/NZS 1891.4:2009
users	no.										
minimum span	X _{min} [m]	2		2		2		2		2	
maximum span	X _{max} [m]	7,5		7,5		15		15		15	
maximum deflection	Y _{max} [m]	1,40		1,40		3,40		3,40		3,40	

For PATROLEND components, see page 56.

PATROL + TOWER / TOWERA2 / TOWERXL

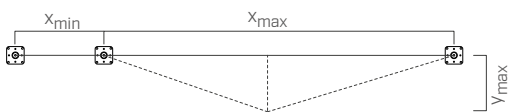

		SPEAR					SPEAREVO				
		EN 795:2012 C	CEN/TS 16415:2013	UNI 11578:2015 C	AS/NZS 1891.2:2001	AS/NZS 1891.4:2009	EN 795:2012 C	CEN/TS 16415:2013	UNI 11578:2015 C	AS/NZS 1891.2:2001	AS/NZS 1891.4:2009
users	no.										
minimum span	X _{min} [m]	2		2		2		2		2	
maximum span	X _{max} [m]	7,5		7,5		15		15		15	
maximum deflection	Y _{max} [m]	1,80		1,80		4,00		4,00		4,00	

For TOWER / TOWERA2 / TOWERXL components, see page 30-34.

PATROL ON WALL

WALL-MOUNTED LIFELINE ON STEEL AND CONCRETE

MINIMALIST DESIGN

The size of the components minimises the aesthetic impact of the safety device on the wall.

FUNCTIONAL

Thanks to the different components availability, it is possible to create customised lifelines according to site requirements.

PRACTICAL

It can be used components that allow the operator to overcome intermediate points and curves by means of a sliding device.



CSA Z259.16 READY
Validated through testing



MAXIMUM NUMBER OF USERS



LOAD DIRECTION



TYPES OF APPLICATION



BIM



VIDEO



MANUALS



PATROL LIFELINE COMPONENTS

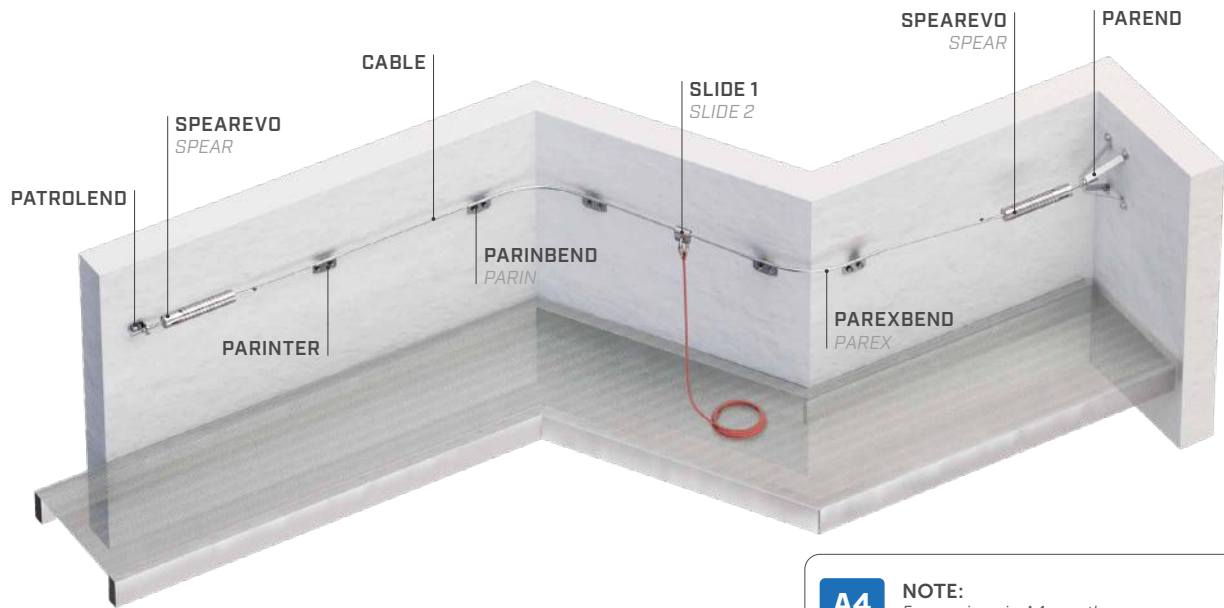

A4
AISI 316

NOTE:

For versions in A4, see the page on components (see page 56).

TECHNICAL DATA*

PATROLEND | PATROLEND A4

substructure	minimum thickness	fasteners
C20/25	116 mm	INA 5.8 M16 VIN-FIX
	170 mm	SKR Ø16
	170 mm	AB1 M16
S235JR	5 mm	DIN 933 M16 DIN 125-1A M16 MUT AI 985 M16

PAREND | PAREND A4

substructure	minimum thickness	fasteners
C20/25	98 mm	INA 5.8 M12 VIN-FIX
	130 mm	SKR Ø12
	140 mm	AB1 M12
S235JR	5 mm	DIN 933 M12 DIN 125-1A M12 MUT AI 985 M12

* The values indicated are the result of experimental tests carried out under the supervision of third parties in accordance with the standard referred to. For a correct calculation report with minimum distances according to the standard requirements, the substructure must be checked by a qualified engineer before installation.



		SPEAR				SPEAREVO					
		EN 795:2012 C	CEN/TS 16415:2013	UNI 11578:2015 C	AS/NZS 1891.2:2001	AS/NZS 1891.4:2009	EN 795:2012 C	CEN/TS 16415:2013	UNI 11578:2015 C	AS/NZS 1891.2:2001	AS/NZS 1891.4:2009
users	no.	👤👤👤👤		👤👤👤👤 (SPAN)		👤👤👤👤		👤👤👤👤 (SPAN)			
minimum span	x_{min} [m]	2		2		2		2			
maximum span	x_{max} [m]	7,5		7,5		15		15			
maximum deflection	y_{max} [m]	1,40		1,40		3,40		3,40			

END ELEMENTS | CODES AND DIMENSIONS

CODE	description	material		B [mm] [in]	H [mm] [in]	L [mm] [in]	s [mm] [in]	pcs	
PATROLEND	end element	AISI 304 stainless steel grade 1.4301	A2 AISI 304	40 1 9/16	61 2 3/8	66 2 5/8	6 0.24	1	
PATROLEND A4	A4 end element	AISI 316 stainless steel grade 1.4401	A4 AISI 316	40 1 9/16	61 2 3/8	66 2 5/8	6 0.24	1	
PAREND	end element	AISI 304 stainless steel grade 1.4301	A2 AISI 304	300 11 3/4	150 6	300 11 3/4	-	1	
PAREND A4	A4 end element	AISI 316 stainless steel grade 1.4401	A4 AISI 316	300 11 3/4	150 6	300 11 3/4	-	1	

PATROL | components

END ELEMENTS | CODES AND DIMENSIONS

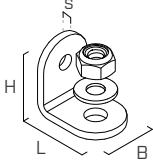
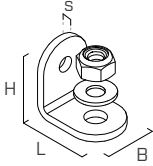
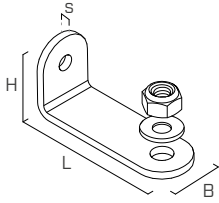
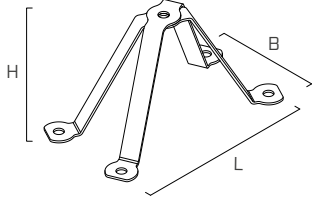
CODE	description	material	B [mm] [in]	H [mm] [in]	L [mm] [in]	s [mm] [in]	pcs	
PATROLTERM	end element	AISI 304 stainless steel grade 1.4301	40 1 9/16	61 2 3/8	66 2 5/8	6 0.24	1	
PATROLTERMA4	A4 end element	AISI 316 stainless steel grade 1.4401						
PATROLEND	end element	AISI 304 stainless steel grade 1.4301	40 1 9/16	61 2 3/8	66 2 5/8	6 0.24	1	
PATROLEND A4	A4 end element	AISI 316 stainless steel grade 1.4401						
PATROLTERML	long end element	AISI 304 stainless steel grade 1.4301	40 1 9/16	61 2 3/8	180 7 1/8	6 0.24	1	
PAREND	end element with 4 feet per side	AISI 304 stainless steel grade 1.4301	300 11 3/4	150 6	300 11 3/4	- -	1	
PAREND A4	A4 end element with 4 feet per side	AISI 316 stainless steel grade 1.4401						

TENSIONERS AND ENERGY ABSORBERS | CODES AND DIMENSIONS

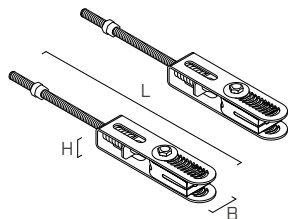
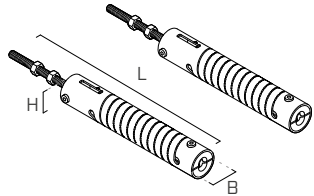
CODE	description	material	B [mm] [in]	H [mm] [in]	L [mm] [in]	s [mm] [in]	pcs	
SPEAR	set of pair of tensioners with absorber	AISI 304 stainless steel grade 1.4301 EN AW 6082 aluminium	50 1 15/16	63 2 1/2	334 13 3/16	- -	1	
SPEAR A4	set of pair of tensioners with A4 absorber	AISI 316 stainless steel grade 1.4401 EN AW 6082 aluminium						
SPEAREVO	set of pair of tensioners with absorber	AISI 304 stainless steel grade 1.4301	50 1 15/16	50 1 15/16	436 17 1/8	- -	1	
SPEAREVO A4	set of pair of tensioners with A4 absorber	AISI 316 stainless steel grade 1.4401						

INTERMEDIATE ELEMENTS | CODES AND DIMENSIONS

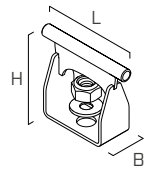
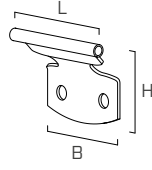
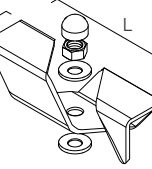
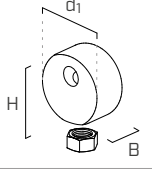
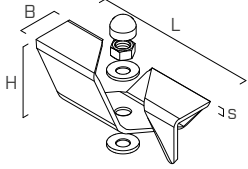
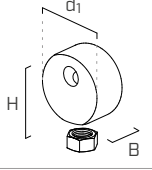
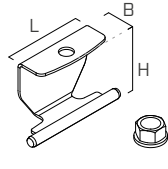
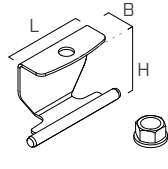
CODE	description	material	d ₁ [mm] [in]	B [mm] [in]	H [mm] [in]	L [mm] [in]	s [mm] [in]	pcs	
PASINT	pass-through intermediate element	AISI 304 stainless steel grade 1.4301	-	35 1 3/8	86 3 3/8	100 4	-	1	
PASINTA4	A4 pass-through intermediate element	AISI 316 stainless steel grade 1.4401	-	35 1 3/8	86 3 3/8	100 4	-	1	
PARINTER	pass-through intermediate element for façades	AISI 304 stainless steel grade 1.4301	-	100 4	88 3 7/16	120 4 3/4	-	1	
PARINTERA4	pass-through intermediate element for A4 façades	AISI 316 stainless steel grade 1.4401	-	100 4	88 3 7/16	120 4 3/4	-	1	
PATROLINT	semi-automatic intermediate element	AISI 304 stainless steel grade 1.4301	-	50 1 15/16	50 1 15/16	375 14 3/4	5 0.20	1	
PATROLMED	non-pass-through intermediate element	AISI 304 stainless steel grade 1.4301 EN AW 6082 aluminium	55 2.17	30 1 3/16	50 1 15/16	-	-	1	
OHINT	pass-through intermediate element for aerial application	AISI 304 stainless steel grade 1.4301	-	40 1 9/16	86 3 3/8	130 5 1/8	-	1	
OHINTA4	pass-through intermediate element for aerial application in A4	AISI 316 stainless steel grade 1.4401	-	40 1 9/16	86 3 3/8	130 5 1/8	-	1	

SLIDING DEVICES | CODES AND DIMENSIONS

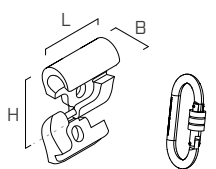
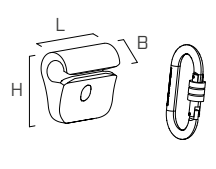
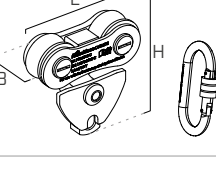
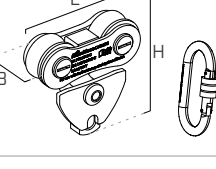
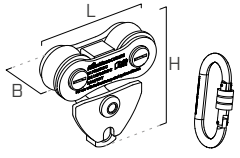
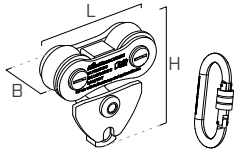
CODE	description	material	d ₁ [mm] [in]	B [mm] [in]	H [mm] [in]	L [mm] [in]	pcs	
SLIDE1	removable sliding device	AISI 304 stainless steel grade 1.4301	-	30 1 3/16	60 2 3/8	60 2 3/8	1	
SLIDE1A4	removable A4 sliding device	AISI 316 stainless steel grade 1.4401	-	30 1 3/16	60 2 3/8	60 2 3/8	1	
SLIDE2	fixed sliding device	AISI 304 stainless steel grade 1.4301	-	30 1 3/16	60 2 3/8	60 2 3/8	1	
SLIDE2A4	fixed A4 sliding device	AISI 316 stainless steel grade 1.4401	-	30 1 3/16	60 2 3/8	60 2 3/8	1	
OHSLIDE	removable sliding device for overhead lifeline	AISI 304 stainless steel grade 1.4301	-	46,5 1 7/8	93 3 11/16	98 3 7/8	1	
OHSLIDEA4	removable sliding device for overhead A4 lifeline	AISI 316 stainless steel grade 1.4401	-	46,5 1 7/8	93 3 11/16	98 3 7/8	1	

ANGLE BRACKETS AND ACCESSORIES | CODES AND DIMENSIONS

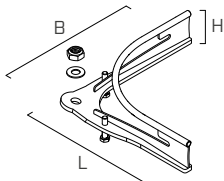
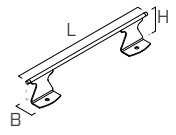
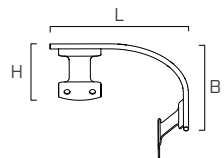
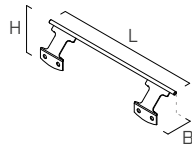
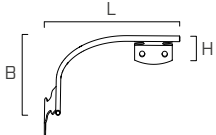
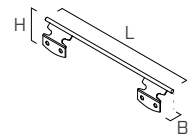
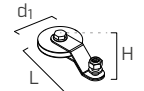
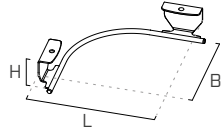
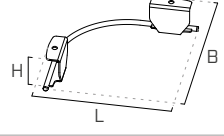
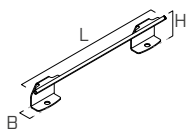
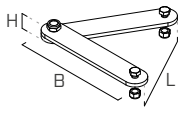
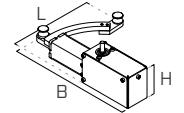
CODE	description	material	d ₁ [mm] [in]	B [mm] [in]	H [mm] [in]	L [mm] [in]	pcs	
PASANG	corner pass-through element	AISI 304 stainless steel grade 1.4301	-	300	69	300	1	
PASANGA4	A4 pass-through angle bracket	AISI 316 stainless steel grade 1.4401	-	11 3/4	2 11/16	11 3/4	1	
PASANGBEND	pass-through angle bracket for adjustable supports 105°-165°	AISI 304 stainless steel grade 1.4301	-	54,5	102	565	1	
PASANGBENDA4	pass-through angle bracket for adjustable A4 supports 105°-165°	AISI 316 stainless steel grade 1.4401	-	2 3/16	4	22 1/4	1	
PAREX	external pass-through angle bracket for façades	AISI 304 stainless steel grade 1.4301	-	326	116	326	1	
PAREXA4	external pass-through angle bracket for A4 façades	AISI 316 stainless steel grade 1.4401	-	12 3/4	4 9/16	12 3/4	1	
PAREXBEND	external pass-through angle bracket for façades adjustable 105°-165°	AISI 304 stainless steel grade 1.4301	-	72	116	565	1	
PAREXBENDA4	external pass-through angle bracket for A4 façades adjustable 105°-165°	AISI 316 stainless steel grade 1.4401	-	2 13/16	4 9/16	22 1/4	1	
PARIN	internal pass-through angle bracket for façades	AISI 304 stainless steel grade 1.4301	-	357	88	357	1	
PARINA4	internal pass-through angle bracket for A4 façades	AISI 316 stainless steel grade 1.4401	-	14	3 7/16	14	1	
PARINBEND	internal pass-through angle bracket for façades adjustable 105°-165°	AISI 304 stainless steel grade 1.4301	-	42	87	565	1	
PARINBENDA4	internal pass-through angle bracket for A4 façades adjustable 105°-165°	AISI 316 stainless steel grade 1.4401	-	1 5/8	3 7/16	22 1/4	1	
PATROLANG	non-pass-through angle bracket	AISI 304 stainless steel grade 1.4301 EN AW 6082 aluminium	90 3.50	-	58 2 1/4	175 6 7/8	1	
OHANGINT	internal pass-through angle bracket for overhead application	AISI 304 stainless steel grade 1.4301	-	354	86	354	1	
OHANGINTA4	inside pass-through angle bracket for aerial application in A4	AISI 316 stainless steel grade 1.4401	-	13 15/16	3 7/16	13 15/16	1	
OHANGEXT	external pass-through angle bracket for overhead application	AISI 304 stainless steel grade 1.4301	-	326	86	326	1	
OHANGEXTA4	outside pass-through angle bracket for aerial application in A4	AISI 316 stainless steel grade 1.4401	-	12 3/4	3 7/16	12 3/4	1	
OHANBEND	external/internal pass-through angle bracket for overhead application, adjustable 105°-165°	AISI 304 stainless steel grade 1.4301	-	39,5	86	565	1	
OHANBENDA4	external/internal pass-through angle bracket for overhead application, adjustable 105°-165° in A4	AISI 316 stainless steel grade 1.4401	-	1 9/16	3 7/16	22 1/4	1	
ANGSUP	support for PASANGBEND, OHANGINT and OHANGEXT	AISI 304 stainless steel grade 1.4031	-	275	16	0 - 550	1	
ANGSUPA4	support for PASANGBENDA4, OHANGINTA4 and OHANGEXTA4	AISI 316 stainless steel grade 1.4401	-	10 7/8	5/8	0 - 19 3/4	1	
BENDTOOL	adjustable angle bracket bending tool (see page 238)	S235JR zinc plated steel	-	353,5 13 15/16	95 3.75	171 - 353 6 3/4 - 13 15/16	1	

ROPE | CODES AND DIMENSIONS

CODE	description	material	pcs
CABLE	stainless steel rope Ø8 7x7	AISI 316 stainless steel grade 1.4401	1

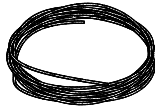

INFORMATION PLATES AND ACCESSORIES | CODES AND DIMENSIONS

CODE	description	material	pcs
PATROLSTOP	limit switch element	-	1
TARGA _{xy} *	information plate for fall protection systems	stainless steel (AISI 304), plastic	1
TARGAHOR _{xy} *	information plate for PATROL and H-RAIL	stainless steel (AISI 304), plastic	1
TARGAVERT _{xy} *	information plate for VERTIGRIP	stainless steel (AISI 304), plastic	1

*xy represents the ISO 639-1 language code, see the table below for reference.

EXAMPLE:

TARGAEN information plate for fall protection systems in EN (English)
TARGAHOREN information plate for PATROL and H-RAIL in EN (English)
TARGAVERTEN information plate for VERTIGRIP in EN (English)

PATROLKIT10 | 10 m LIFELINE KIT

CODE	description	material	
PATROLKIT10	PATROLTERM end element	AISI 304 stainless steel grade 1.4301	2
	SPEAR set of pair of tensioners with absorber	AISI 304 stainless steel grade 1.4301 EN AW 6082 aluminium	1
	CABLE stainless steel rope Ø8 7x7 11 m	AISI 316 stainless steel grade 1.4401	1



Also includes a 22 kN webbing length 0.4 m EN 795/B EN 566 - EN 354.

PATROLKIT15 | 15 m LIFELINE KIT

CODE	description	material	
PATROLKIT15	PATROLTERM end element	AISI 304 stainless steel grade 1.4301	2
	SPEAR set of pair of tensioners with absorber	AISI 304 stainless steel grade 1.4301 EN AW 6082 aluminium	1
	CABLE stainless steel rope Ø8 7x7 16 m	AISI 304 stainless steel grade 1.4301	1



Also includes a 22 kN webbing length 0.4 m EN 795/B EN 566 - EN 354.

PATROLKIT30 | 30 m LIFELINE KIT

CODE	description	material	
PATROLKIT30	PATROLTERM end element	AISI 304 stainless steel grade 1.4301	2
	SPEAR set of pair of tensioners with absorber	AISI 304 stainless steel grade 1.4301 EN AW 6082 aluminium	1
	PATROLMED non-pass-through intermediate element	AISI 304 stainless steel grade 1.4301 EN AW 6082 aluminium	1
	CABLE stainless steel rope Ø8 7x7 31 m	AISI 316 stainless steel grade 1.4401	1

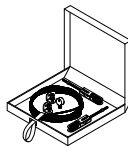

Also includes a 22 kN webbing length 0.4 m EN 795/B EN 566 - EN 354.

H-RAIL

RAIL SYSTEM FOR HORIZONTAL AND VERTICAL USE

TO ALWAYS WORK ON THE RIGHT RAIL.

The H-RAIL rail system is safe and versatile. It can be used to create rigid horizontal or vertical anchor lines with minimal fastenings. Either curved or straight rigid anchor lines can be developed thanks to the system's modularity. H-RAIL is also suitable for rope access work on building façades. Sliding devices are available for different applications: choose the one that suits you and operate safely with H-RAIL!



FASTENING BRACKETS SPAN

FALL PROTECTION WORK

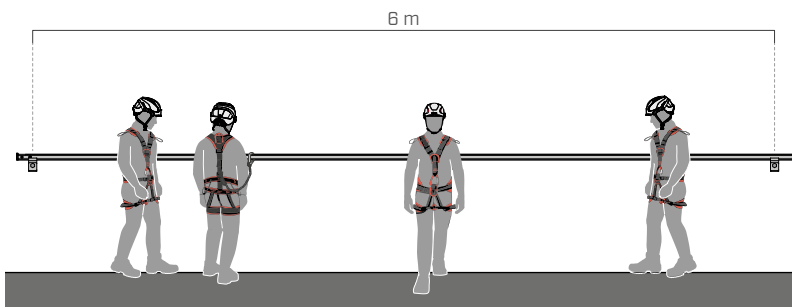





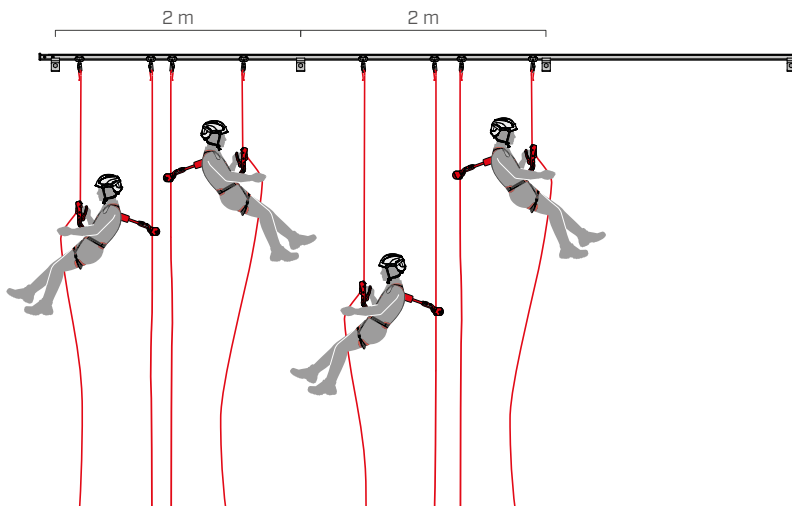

The distance between fastening brackets for fall protection or restraint work can reach up to 6 metres, allowing 4 operators to use the system simultaneously on the same span.

ROPE ACCESS WORK



For rope access work, the maximum distance between the fastening brackets is 2 m, allowing 4 operators to use the system simultaneously and 2 on the same span.

SLIDING DEVICE

	RAILSLIDE RAILSLIDEA4	RAILSLIDEWALL RAILSLIDEWA4	RAILSLIDE0H RAILSLIDE0HA4	RAILSLIDERA RAILSLIDERA4	RAILSLIDEV RAILSLIDEVA4	RAILSLIDEVH RAILSLIDEVHA4
						
horizontal	✓	✓	✓	✓		✓
vertical					✓	✓
inclined						✓
universal						✓
material	A2 AISI 304 A4 AISI 316	A2 AISI 304 A4 AISI 316	A2 AISI 304 A4 AISI 316	A2 AISI 304 A4 AISI 316	A2 AISI 304 A4 AISI 316	A2 AISI 304 A4 AISI 316
certification	EN 795 Type D	EN 795 Type D	EN 795 Type D	EN 795 Type D	EN 353-1:2014 + A1:2018	EN 353-1:2014 + A1:2018 EN 795 Type D
removable	✓	✓	✓	✓	✓	✓
overhead			✓			
on wall	✓	✓		✓		✓
rope access work			✓	✓		

KEY POINTS

COLOUR AND ANODISING

On request, the system can be personalised with RAL colours.
Anodising is similarly available in a range of colours.

WHAT DOES THE CLIENT NEED?

CORROSION PROTECTION

ANODISING	
CORROSION CATEGORY	CORROSION PROTECTION
C ₁	10 µm
C ₂	15 µm
C ₃	20 µm
C ₄	210 µm
C ₅	20 or 25 µm
C _x	special analysis required

CORROSION PROTECTION + COLOR

POWDER COATING		
CORROSION CATEGORY	LOW SOLAR RADIATION	HIGH SOLAR RADIATION
C ₁	powder CLASS 1	powder CLASS 2 or 3
C ₂	powder CLASS 1	powder CLASS 2 or 3
C ₃	powder CLASS 1	powder CLASS 2 or 3
C ₄	powder CLASS 1 and Oxidation (FLASH)	powder CLASS 2 or 3 and Oxidation (FLASH)
C ₅	powder CLASS 1 and Oxidation (FLASH)	powder CLASS 2 or 3 and Oxidation (FLASH)
C _x	special analysis required	

CUSTOM CURVES AND ANGLES

The rail can be custom curved, with a minimum curvature radius of 200 mm and curvature angle ranging from 90° to 180°.



LOADS

The loads on the substructure can range from a minimum of 6 kN to a maximum of 31 kN.

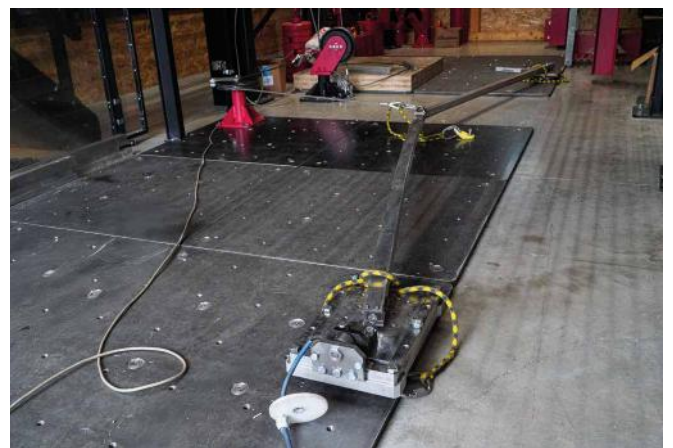

I H-RAIL OVERHEAD

HORIZONTAL OVERHEAD RAIL SYSTEM

ADAPTABLE

The rail can be mounted on different types of substructures using specific plates.

FUNCTIONAL

The rail allows operators to work with their hands free and in safety by using sliding and retractable devices.

SAFE

The system has been tested for use in rope access work with multiple operators.

EN 795:2012 D	CEN/TS 18415:2013	UNI 11578:2015 D	AS/NZS 1891.4:2009	AS/NZS 1891.2:2001	BS 8610:2017 01 - 02 - 03 - 05
---------------------	----------------------	------------------------	-----------------------	-----------------------	---



MAXIMUM NUMBER
OF USERS



LOAD DIRECTION



TYPES OF
APPLICATION



H-RAIL COMPONENTS

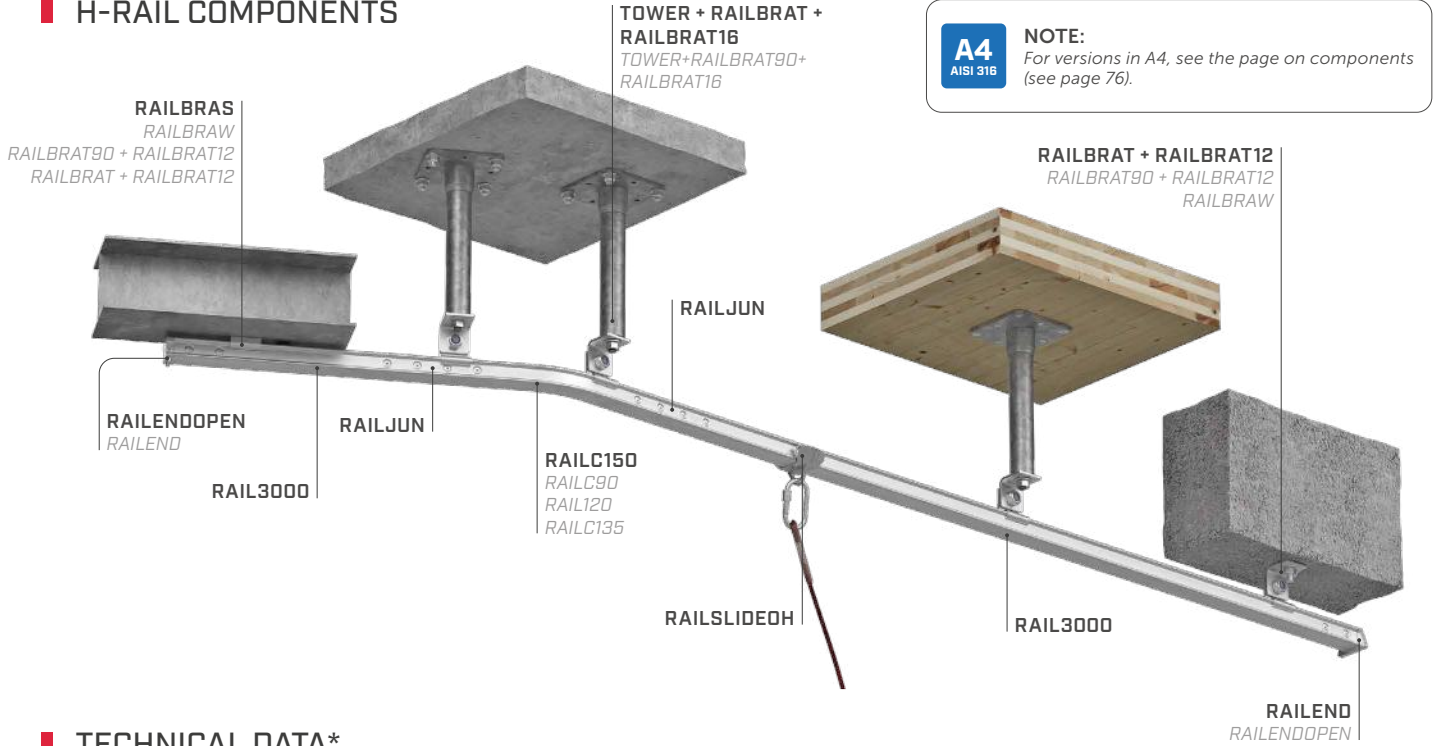

TECHNICAL DATA*

substructure	minimum thickness	support	fasteners	substructure	minimum thickness	support	fasteners
GL24h	160 mm	RAILBRAT + RAILBRATW	VGS (EVO) Ø11	S235JR	5 mm	RAILBRAT + RAILBRAT12	DIN 933 M12 MUT AI 985 M12 DIN 7991 M10
		RAILBRAT90 + RAILBRATW				RAILBRAT90 + RAILBRAT12	
		RAILBRAU				RAILBRAU	
CLT	160 mm	RAILBRAT + RAILBRATW	VGS (EVO) Ø13	TOWER ⁽¹⁾	5 mm	RAILBRAT + RAILBRAT16	-
		RAILBRAT90 + RAILBRATW				RAILBRAT90 + RAILBRAT16	
		RAILBRAU					
C20/25	140 mm	RAILBRAT + RAILBRAT12	AB1 M12 INA 5.8 M12 VIN-FIX SKR Ø12				
		RAILBRAT90 + RAILBRAT12					
		RAILBRAU					

* The values indicated are the result of experimental tests carried out under the supervision of third parties in accordance with the standard referred to. For a correct calculation report with minimum distances according to the standard requirements, the substructure must be checked by a qualified engineer before installation.

⁽¹⁾ For TOWER fastening, see page 30.

fall protection restraint		EN 795:2012 D	CEN/TS 16415:2013	UNI 11578:2015 D	AS/NZS 1891.2:2001	AS/NZS 1891.4:2009	BS 8610:2017 03 - 05
users (system)	no.				N.A.		
users (span)	no.						
maximum span	x_{max} [m]	6	6	6	6	6	6
suspension		EN 795:2012 D	CEN/TS 16415:2013	UNI 11578:2015 D	AS/NZS 1891.2:2001	AS/NZS 1891.4:2009	BS 8610:2017 03 - 05
users (system)	no.				N.A.		
users (span)	no.						
maximum span	x_{max} [m]	2	2	2	2	2	2

For H-RAIL OVERHEAD components, see page 76.

I H-RAIL ON WALL

HORIZONTAL WALL-MOUNTED RAIL SYSTEM

AESTHETICS

Supports with minimal visual impact are available for direct fastening to the structure.

FUNCTIONAL

It can be used with special sliding devices both for fall protection work and rope access work.

SIMPLE

It is compatible with various substructures, including timber, concrete and steel, effectively addressing all construction site requirements.

EN 795:2012 D	CEN/TS 16415:2013	UNI 11578:2015 D	AS/NZS 1891.4:2009	AS/NZS 1891.2:2001	BS 8610:2017 01-02-03 -05
---------------------	----------------------	------------------------	-----------------------	-----------------------	------------------------------------



MAXIMUM NUMBER OF USERS



LOAD DIRECTION



TYPES OF APPLICATION



H-RAIL COMPONENTS

A4
AISI 316

NOTE:

For versions in A4, see the page on components (see page 76).

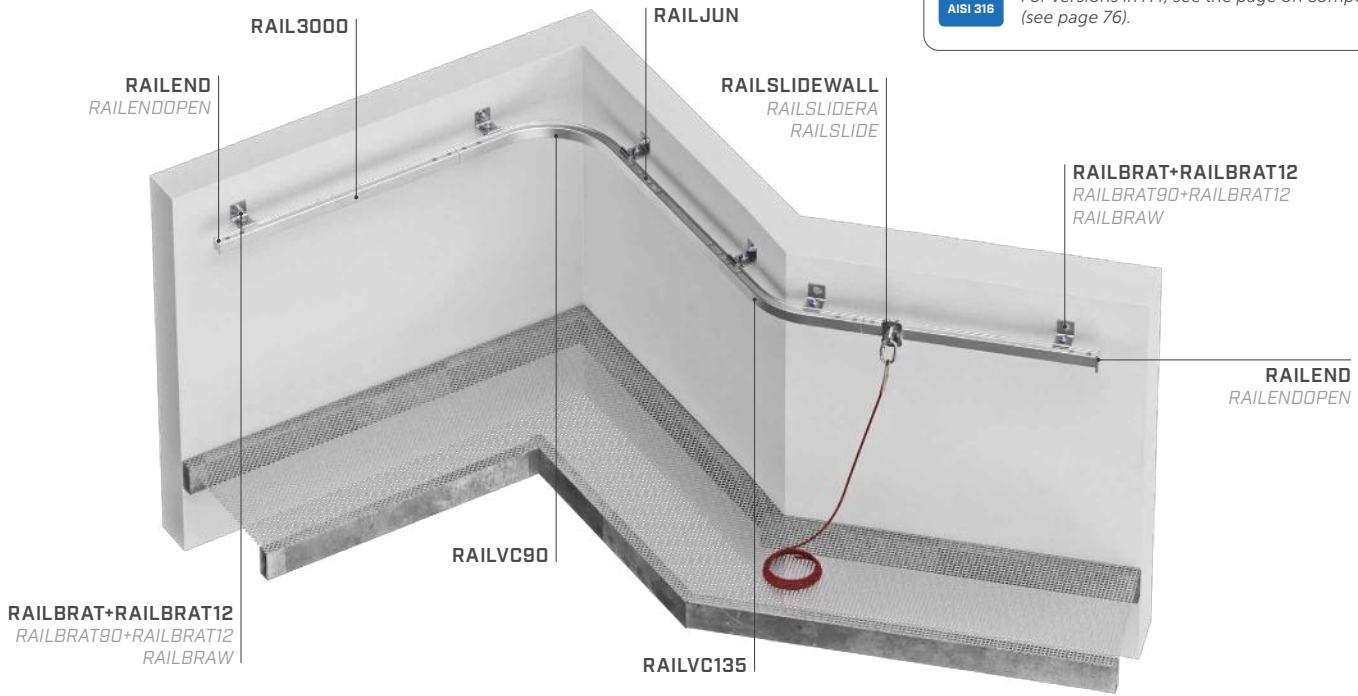

TECHNICAL DATA*

substructure	minimum thickness	support	fasteners
GL24h	160 mm	RAILBRAT + RAILBRATW RAILBRAT90 + RAILBRATW RAILBRAU	VGS (EVO) Ø11
CLT	160 mm	RAILBRAT + RAILBRATW RAILBRAT90 + RAILBRATW RAILBRAU	VGS (EVO) Ø13

substructure	minimum thickness	support	fasteners
C20/25	140 mm	RAILBRAT + RAILBRAT12 RAILBRAT90 + RAILBRAT12 RAILBRAU	AB1 M12 INA 5.8 M12 VIN-FIX SKR Ø12
S235JR	5 mm	RAILBRAT + RAILBRAT12 RAILBRAT90 + RAILBRAT12 RAILBRAU RAILBRAS	DIN 933 M12 MUT AI 985 M12 DIN 7991 M10

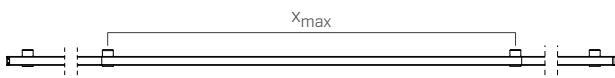

* The values indicated are the result of experimental tests carried out under the supervision of third parties in accordance with the standard referred to. For a correct calculation report with minimum distances according to the standard requirements, the substructure must be checked by a qualified engineer before installation.

fall protection restraint		EN 795:2012 D	CEN/TS 16415:2013	UNI 11578:2015 D	AS/NZS 1891.2:2001	AS/NZS 1891.4:2009	BS 8610:2017 01 - 02 - 05
users (system)	no.				N.A.		
users (span)	no.						
maximum span	x_{max} [m]	6	6	6	6	6	6

suspension		EN 795:2012 D	CEN/TS 16415:2013	UNI 11578:2015 D	AS/NZS 1891.2:2001	AS/NZS 1891.4:2009	BS 8610:2017 03 - 05
users (system)	no.				N.A.		
users (span)	no.						
maximum span	x_{max} [m]	2	2	2	2	2	2

For H-RAIL ON WALL components, see page 76.

H-RAIL + SOLID

RAIL SYSTEM ON RIGID SUPPORT FOR ROPE ACCESS WORK

DESIGNED FOR ROPE ACCESS WORK

The highly rigid and very strong support, combined with the jaw-plate anchor system, ensures safety and comfort during rope access work.

LIGHT

Made from aluminium alloy, the lightweight support is easy to handle and install.

ADAPTABLE

Available in heights between 400 and 1000 mm, it adapts to different roofing thicknesses.

EN 795:2012 D	CEN/TS 18415:2013	UNI 11578:2015 D	AS/NZS 1891.4:2009	AS/NZS 1891.2:2001	BS 8610:2017 A3/A5/D	AS/NZS 5532:2013
---------------	-------------------	------------------	--------------------	--------------------	----------------------	------------------

ANSI* Z359.18 -2017 A *The system has been developed and tested in full accordance with the static, dynamic and residual strength requirements outlined in the relative ANSI standard.



MAXIMUM NUMBER OF USERS



LOAD DIRECTION



TYPES OF APPLICATION

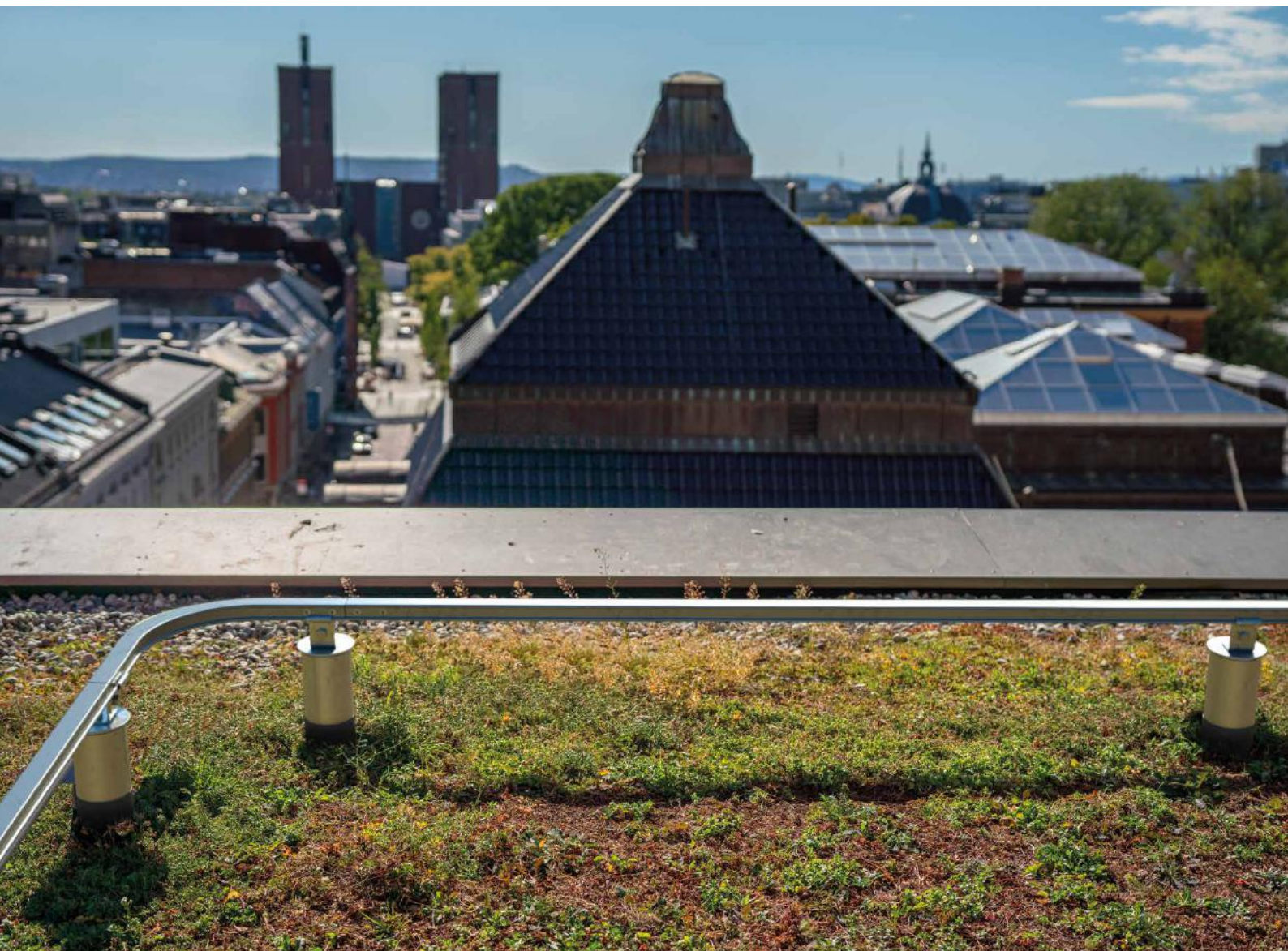
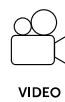

H-RAIL COMPONENTS

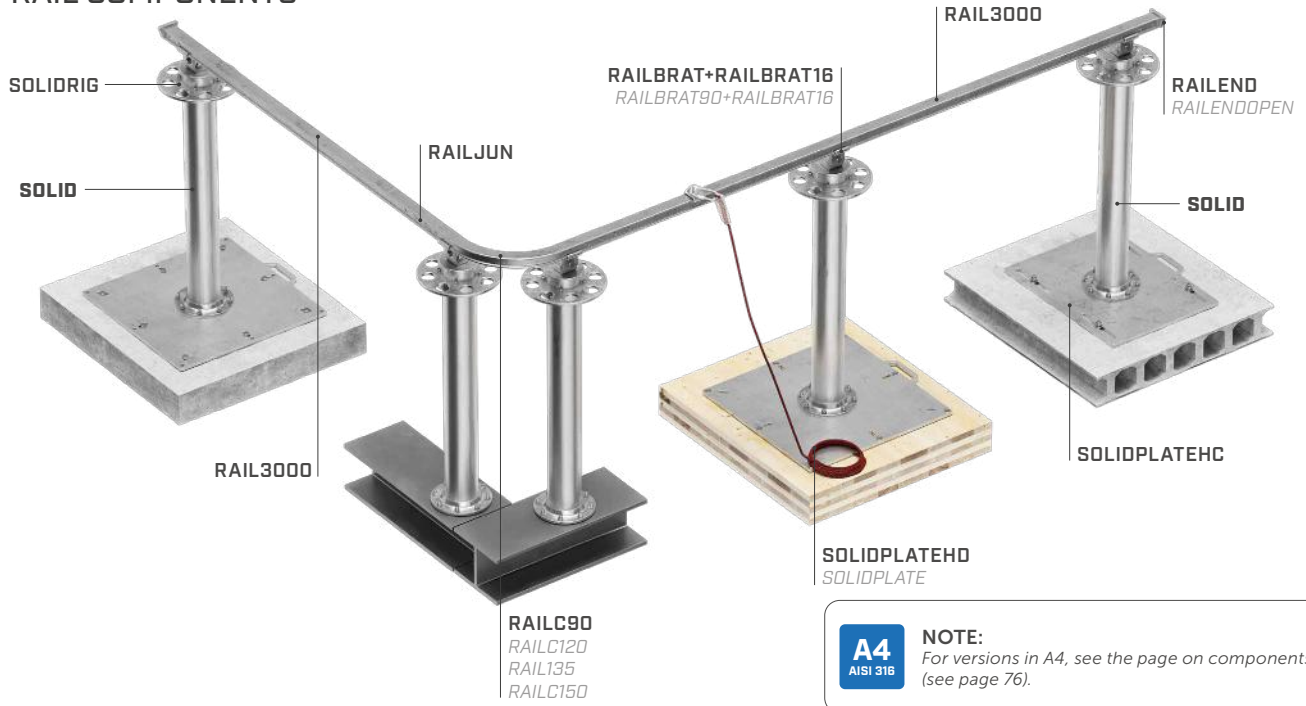

A4
AISI 316

NOTE:

For versions in A4, see the page on components (see page 76).

TECHNICAL DATA**

substructure	minimum thickness	fasteners
CLT	160 mm	VGS (EVO) Ø13 HUS12
C20/25	-	INA Ø16 8.8
S235	15 mm	bolt or rod M12 10.9

substructure	minimum thickness	fasteners
C20/25	140 mm	AB1 Ø12
		SKR (EVO) Ø12
		INA Ø12 8.8 VIN-FIX



**The values indicated are the result of experimental tests carried out under the supervision of third parties in accordance with the standard referred to. For a correct calculation report with minimum distances according to the standard requirements, the substructure must be checked by a qualified engineer before installation.

	fall protection restraint		EN 795:2012 D	CEN/TS 16415:2013	UNI 11578:2015 D	AS/NZS 1891.2:2001	AS/NZS 1891.4:2009	BS 8610:2017 01-02-05
			users (system)	no.				N.A.
users (span)	no.							
maximum span	x_{max} [m]	6	6	6				

	suspension		EN 795:2012 D	CEN/TS 16415:2013	UNI 11578:2015 D	AS/NZS 1891.2:2001	AS/NZS 1891.4:2009	BS 8610:2017 03-05	with SOLIDRIG		
			AS/NZS 5532:2013	BS 8610:2017 A3/A5	ANSI* Z359.1B -2017 A						
users (system)	no.					N.A.					
users (span)	no.						-	-	-		
maximum span	x_{max} [m]	2	2	2	-	-					

For H-RAIL+ SOLID components, see page 76.

For SOLID components, see page 36.

H-RAIL + TOWER

HORIZONTAL RAIL SYSTEM ON SUPPORTS

COMPATIBLE

It can be assembled in combination with all TOWER brackets.

FUNCTIONAL

The combination with TOWER supports allows to raise the rail to overcome obstacles in the roof.

SIMPLE

The special mounting plate ensures quick and simple installation of the rail on the TOWER supports.

EN 795:2012 D	CEN/TS 16415:2013	UNI 11578:2015 D	AS/NZS 1891.4:2009	AS/NZS 1891.2:2001	BS 8610:2017 01 - 02 - 03 - 05
---------------------	----------------------	------------------------	-----------------------	-----------------------	---



MAXIMUM NUMBER
OF USERS



LOAD DIRECTION



TYPES OF
APPLICATION

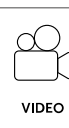

I H-RAIL ON FLOOR

HORIZONTAL RAIL SYSTEM

LOW PROFILE

The rail occupies minimal space on the roof and has a low visual impact.

COMPLETE

The system can be used for different applications (horizontal, vertical and overhead) by using the specific sliding devices.

FAST INSTALLATION

The wide fastening span (6 m) ensures rapid assembly due to the limited number of fastening points.

EN 795:2012 D	CEN/TS 18418:2013	UNI 11578:2015 D	AS/NZS 1891.4:2009	AS/NZS 1891.2:2001	BS 8610:2017 01 - 02 - 03 - 05
---------------------	----------------------	------------------------	-----------------------	-----------------------	---



MAXIMUM NUMBER
OF USERS



LOAD DIRECTION



TYPES OF
APPLICATION

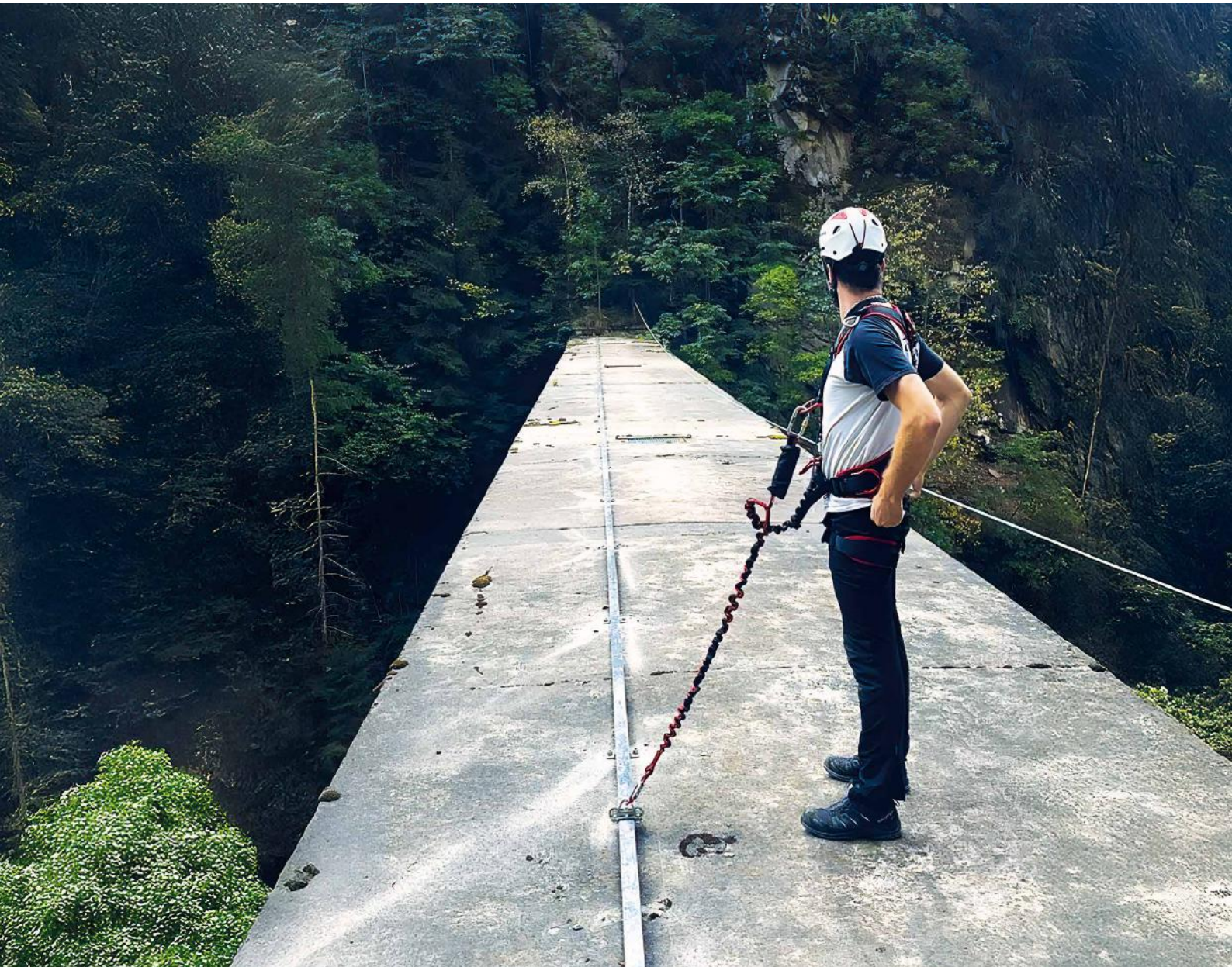
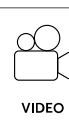
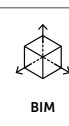

H-RAIL COMPONENTS

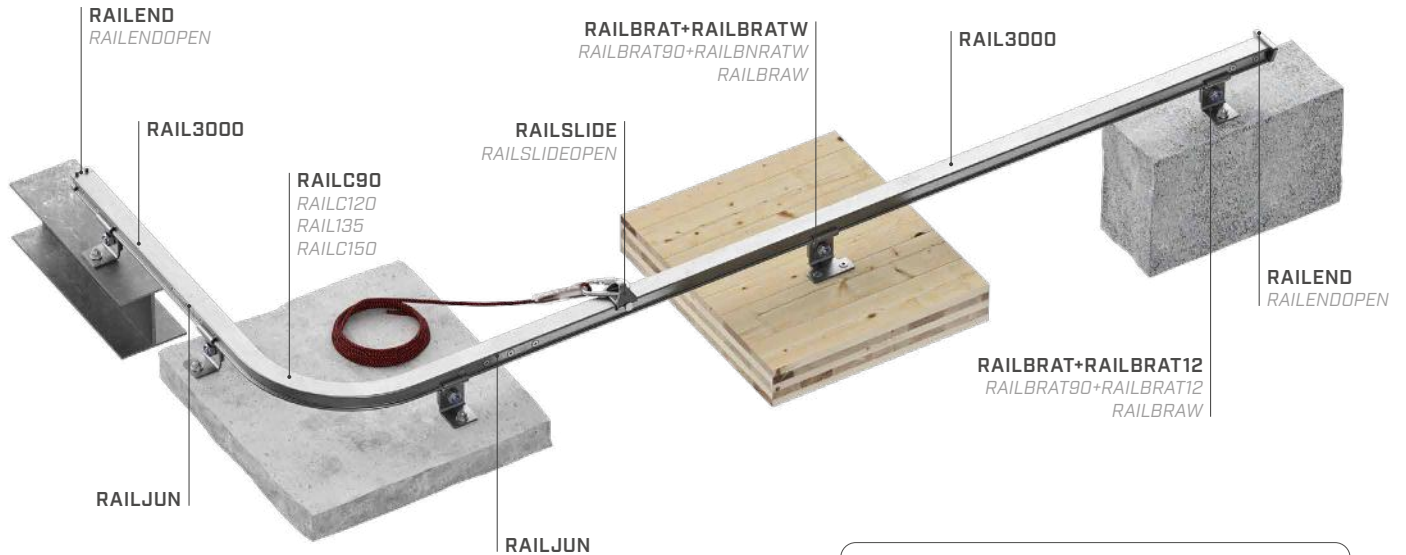

A4
AISI 316

NOTE:

For versions in A4, see the page on components (see page 76).

TECHNICAL DATA*

substructure	minimum thickness	support	fasteners
GL24h	160 mm	RAILBRAT + RAILBRATW RAILBRAT90 + RAILBRATW RAILBRAW	VGS (EVO) Ø11
CLT	160 mm	RAILBRAT + RAILBRATW RAILBRAT90 + RAILBRATW RAILBRAW	VGS (EVO) Ø13

substructure	minimum thickness	support	fasteners
C20/25	140 mm	RAILBRAT + RAILBRAT12 RAILBRAT90 + RAILBRAT12 RAILBRAW	AB1 M12 INA 5.8 M12 VIN-FIX SKR Ø12
S235JR	5 mm	RAILBRAT + RAILBRAT12 RAILBRAT90 + RAILBRAT12 RAILBRAW RAILBRAS	DIN 933 M12 MUT AI 985 M12 DIN 7991 M10

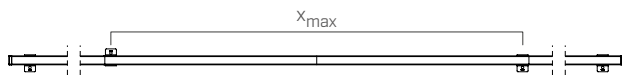

* The values indicated are the result of experimental tests carried out under the supervision of third parties in accordance with the standard referred to. For a correct calculation report with minimum distances according to the standard requirements, the substructure must be checked by a qualified engineer before installation.

		fall protection restraint	EN 795:2012 D	CEN/TS 16415:2013	UNI 11578:2015 D	AS/NZS 1891.2:2001	AS/NZS 1891.4:2009	BS 8610:2017 01 - 02 - 05
users (system)	no.					N.A.		
users (span)	no.							
maximum span	x_{max} [m]		6			6		6

		suspension	EN 795:2012 D	CEN/TS 16415:2013	UNI 11578:2015 D	AS/NZS 1891.2:2001	AS/NZS 1891.4:2009	BS 8610:2017 03 - 05
users (system)	no.					N.A.		
users (span)	no.							
maximum span	x_{max} [m]		2			2		2

For H-RAIL ON FLOOR components, see page 76.

H-RAIL VERTICAL



RAIL SYSTEM FOR VERTICAL USE ON LADDER



FUNCTIONAL

The sliding device with integrated energy absorber allows continuous ascent and descent in safe and comfortable conditions.

DURABLE

The elements in AISI 304 stainless steel and aluminium alloy provide excellent resistance to corrosion.

PRACTICAL

It is a user-friendly system comprised of few elements that are easy to install.



MAXIMUM NUMBER OF USERS







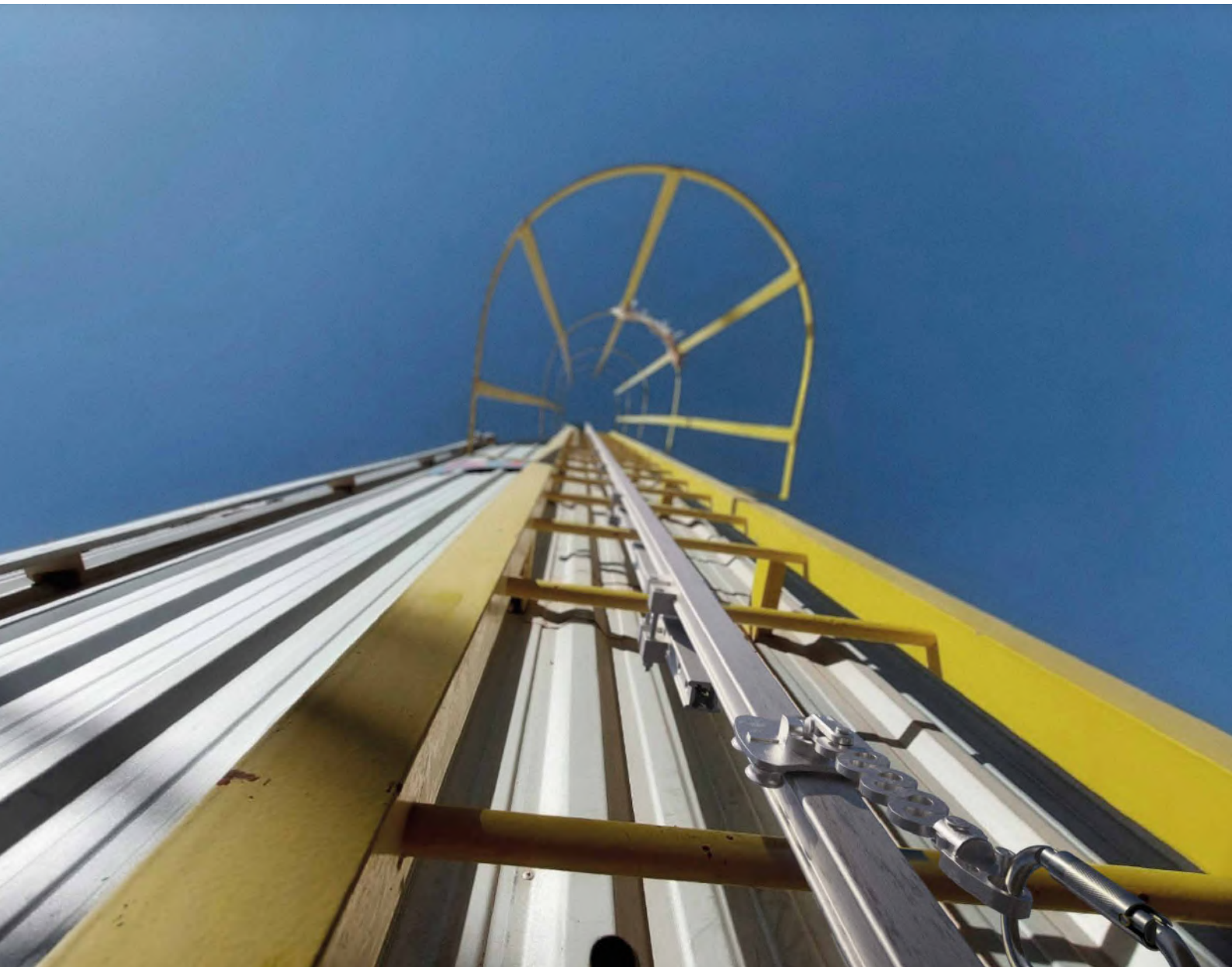
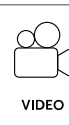

LOAD DIRECTION



TYPES OF APPLICATION



TECHNICAL DATA

 fall protection		 EN 353-1:2014 + A1:2017	 AS/NZS 1891.3:2020
		 RFU 11.119	
maximum number of users	no.		
minimum distance between operators	Z_{min} [m]	3	3
minimum span	X_{min} [m]	0,5	0,5
maximum span	X_{max} [m]	3	3

installation range

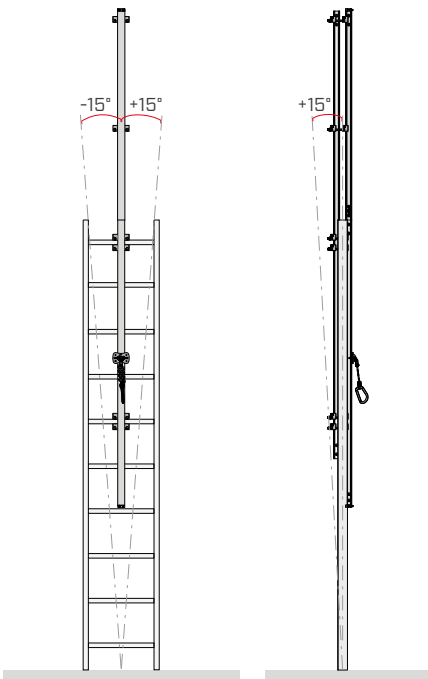
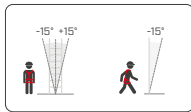

step shape

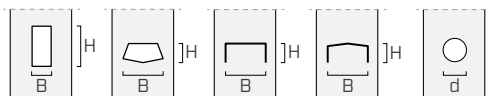

B from 20 to 100 mm
H from 10 to 60 mm
d max 60 mm

H-RAIL VERTICAL COMPONENTS

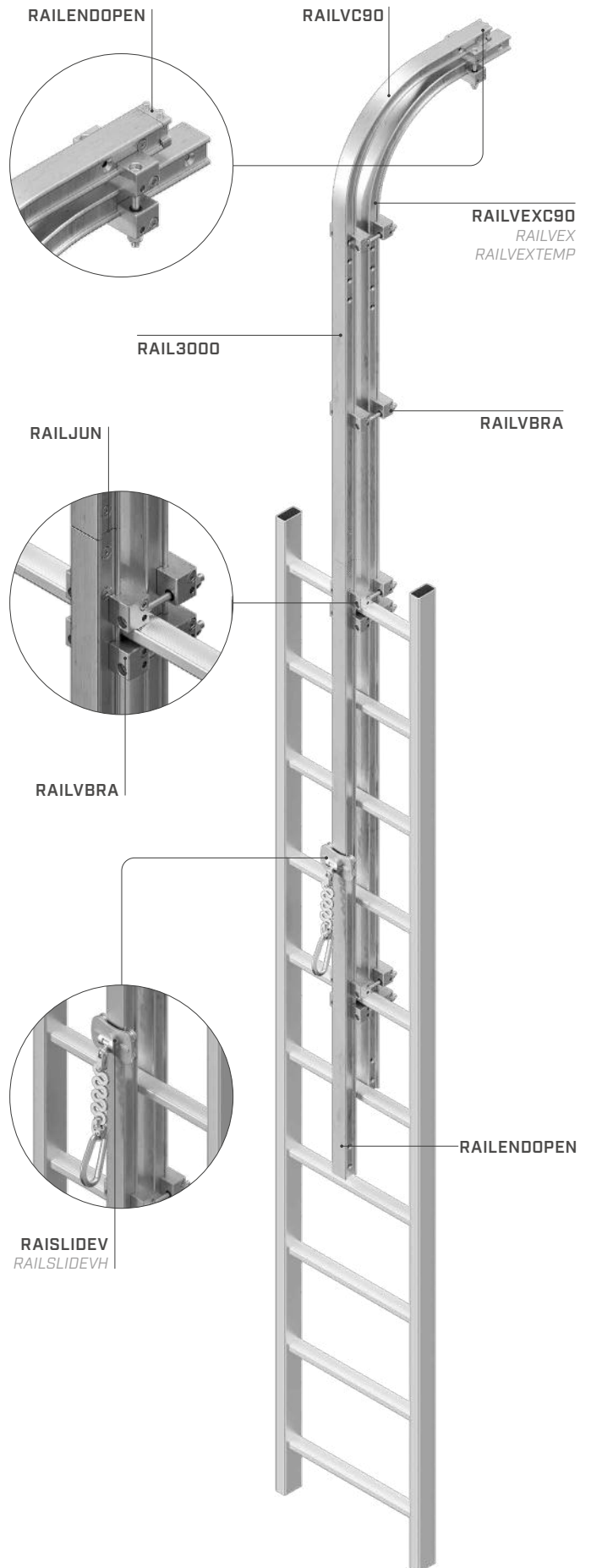

NOTE:

For versions in A4, see the page on components (see page 76).

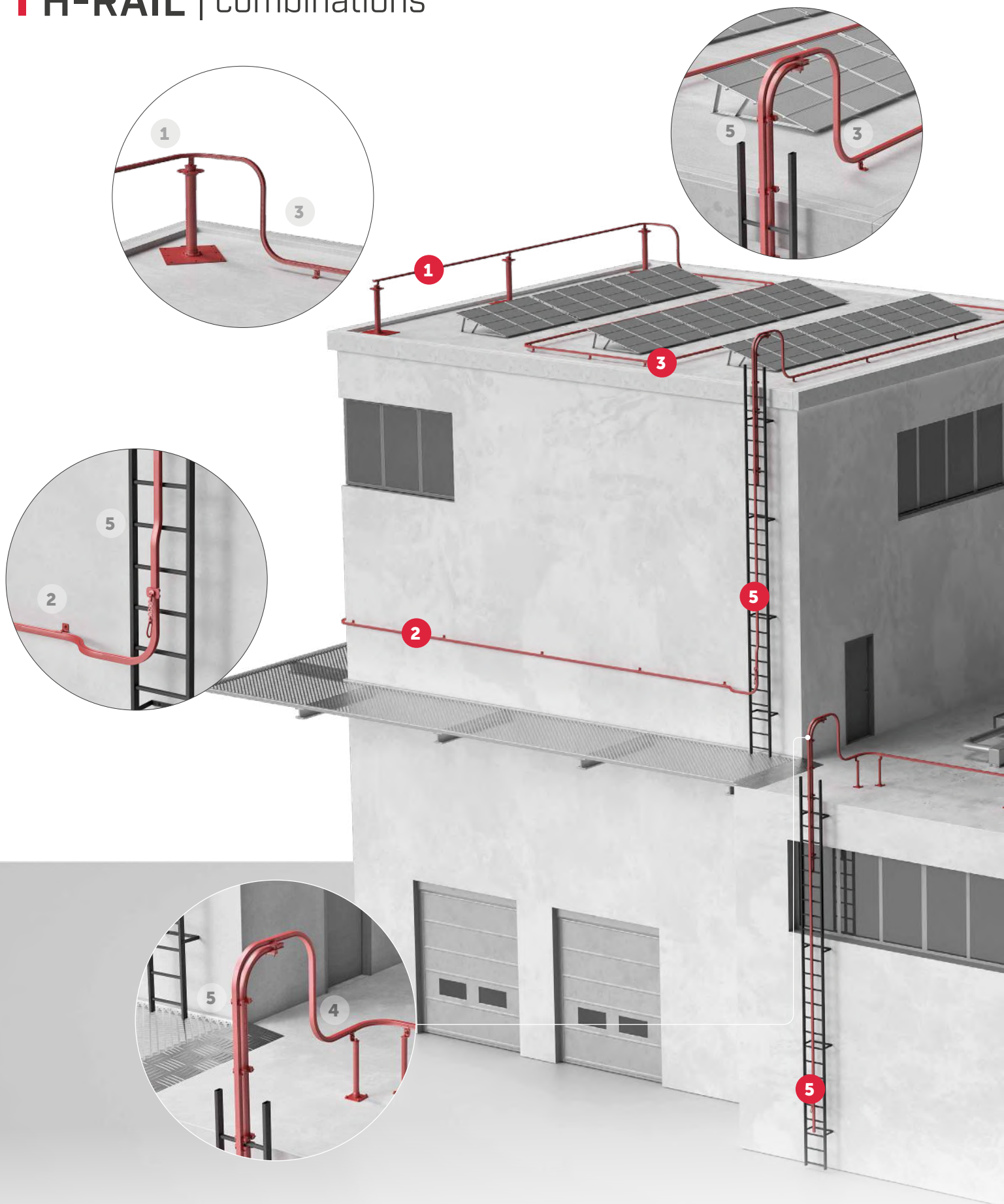

H-RAIL | combinations

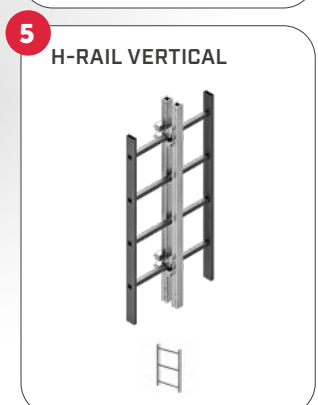
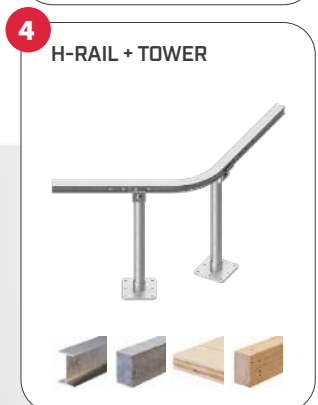
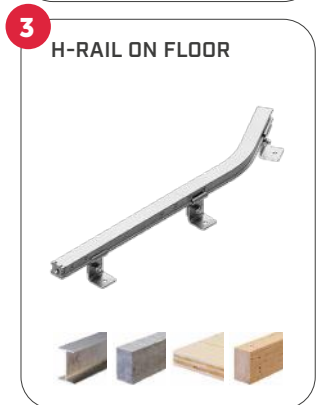
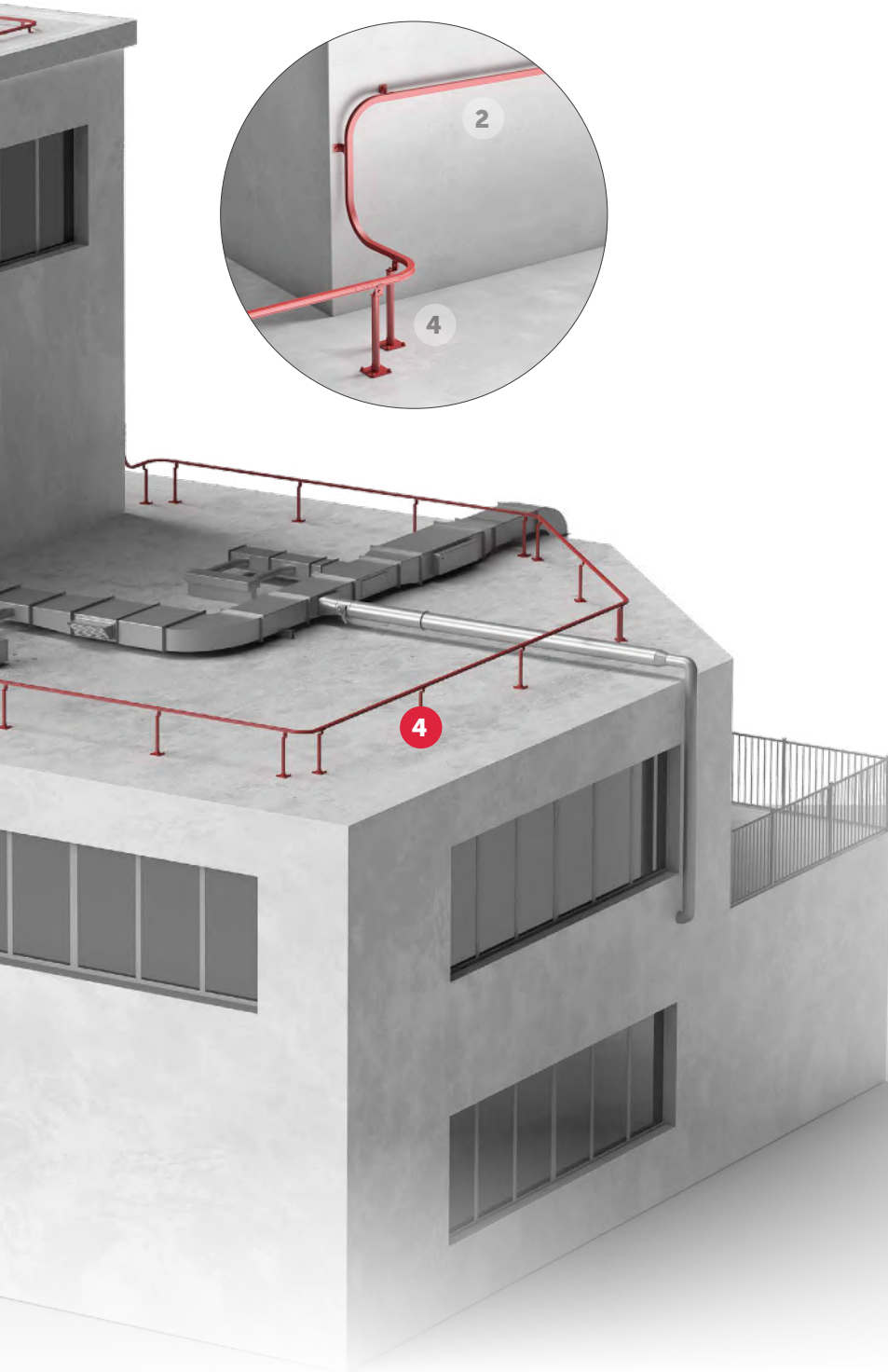

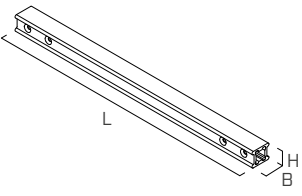
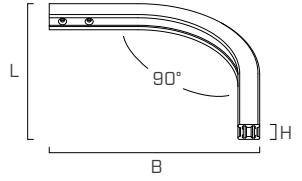
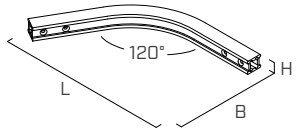

H-RAIL | components

RAILS | CODES AND DIMENSIONS

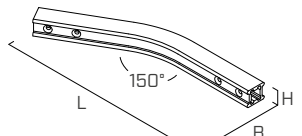
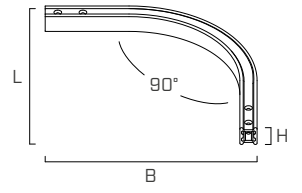
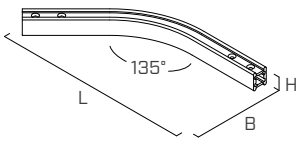
CODE	description	material	B [mm] [in]	H [mm] [in]	L [mm] [in]	pcs	
RAIL3000	3 m aluminium rail	EN AW 6063 (T6)	49 1 15/16	41 1 5/8	3000 118 1/8	1	
RAILC90	aluminium 90° bend for rail	EN AW 6063 (T6)	475 18 11/16	41 1 5/8	475 18 11/16	1	
RAILC120	aluminium 120° bend for rail	EN AW 6063 (T6)	335 13 1/4	41 1 5/8	538 21 3/16	1	
RAILC135	aluminium 135° bend for rail	EN AW 6063 (T6)	257 10 1/8	41 1 5/8	536 21 1/8	1	
RAILC150	aluminium 150° bend for rail	EN AW 6063 (T6)	180 7	41 1 5/8	511 20 3/16	1	
RAILVC90	aluminium vertical 90° bend for rail	EN AW 6063 (T6)	506 19 15/16	49 1 15/16	506 19 15/16	1	
RAILVC135	aluminium vertical 135° bend for rail	EN AW 6063 (T6)	260 10 1/4	49 1 15/16	558 21 15/16	1	

SUPPORTS | CODES AND DIMENSIONS

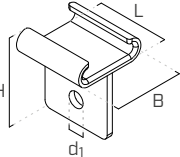
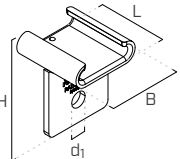
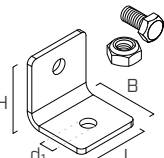
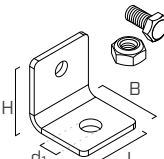
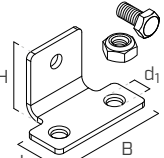
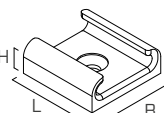
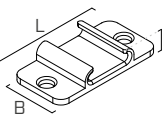
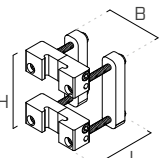
CODE	description	material	d ₁ [mm] [in]	B [mm] [in]	H [mm] [in]	L [mm] [in]	pcs	
RAILBRAT	support to be combined with RAILBRAT12 - RAILBRAT16 - RAILBRAW	AISI 304 stainless steel grade 1.4301	13,5 9/16	60 2 3/8	74 2 15/16	60 2 3/8	1	
RAILBRATA4	support in A4 to be combined with RAILBRAT12A4 - RAILBRAT16A4 - RAILBRAWA4	AISI 316 stainless steel grade 1.4401						
RAILBRAT90	support to be combined with RAILBRAT12 - RAILBRAT16 - RAILBRAW	AISI 304 stainless steel grade 1.4301	13,5 9/16	60 2 3/8	74 2 15/16	60 2 3/8	1	
RAILBRAT90A4	support in A4 to be combined with RAILBRAT12A4 - RAILBRAT16A4 - RAILBRAWA4	AISI 316 stainless steel grade 1.4401						
RAILBRAT12	bottom element to be combined with RAILBRAT or RAILBRAT90	AISI 304 stainless steel grade 1.4301	13,5 9/16	60 2 3/8	63 2 1/2	60 2 3/8	1	
RAILBRAT12A4	bottom element in A4 to be combined with RAILBRATA4 or RAILBRAT90A4	AISI 316 stainless steel grade 1.4401						
RAILBRAT16	bottom element to be combined with RAILBRAT or RAILBRAT90	AISI 304 stainless steel grade 1.4301	17 11/16	60 2 3/8	63 2 1/2	60 2 3/8	1	
RAILBRAT16A4	bottom element in A4 to be combined with RAILBRATA4 or RAILBRAT90A4	AISI 316 stainless steel grade 1.4401						
RAILBRATW	bottom element for timber to be combined with RAILBRAT or RAILBRAT90	AISI 304 stainless steel grade 1.4301	14 9/16	103 4 1/16	63 2 1/2	60 2 3/8	1	
RAILBRATWA4	bottom element in A4 for timber to be combined with RAILBRATA4 or RAILBRAT90A4	AISI 316 stainless steel grade 1.4401						
RAILBRAS	support for installation on steel	AISI 304 stainless steel grade 1.4301	11 7/16	60 2 3/8	22 7/8	60 2 3/8	1	
RAILBRASA4	A4 support for installation on steel	AISI 316 stainless steel grade 1.4401						
RAILBRAW	support for installation on timber and concrete	AISI 304 stainless steel grade 1.4301	14 9/16	60 2 3/8	22 7/8	120 4 3/4	1	
RAILBRAWA4	A4 support for installation on timber and concrete	AISI 316 stainless steel grade 1.4401						
RAILVBRA	support for vertical installation on ladder	AISI 304 stainless steel grade 1.4301 EN AW 6082 aluminium	- -	117 4 3/8	139 5 11/16	157 4 5/8	1	

H-RAIL | components

END ELEMENTS | CODES AND DIMENSIONS

CODE	description	material	B [mm] [in]	H [mm] [in]	L [mm] [in]	pcs	
RAILEND	fixed end element	AISI 304 stainless steel grade 1.4301	85 3 3/8	49 1 15/16	55 2 3/16	1	
RAILENDA4	A4 fixed end element	AISI 316 stainless steel grade 1.4401					
RAILENDOPEN	opening end element	AISI 304 stainless steel grade 1.4301	49 1 15/16	49 1 15/16	60 2 3/8	1	
RAILENDOPENA4	A4 opening end element	AISI 316 stainless steel grade 1.4401					
RAILVEND	opening end element for vertical installation on ladder	AISI 304 stainless steel grade 1.4301 EN AW 6063 aluminium	49 1 15/16	108 4 1/4	41 1 5/8	1	

JOINTS | CODES AND DIMENSIONS

CODE	description	material	B [mm] [in]	H [mm] [in]	L [mm] [in]	pcs	
RAILJUN	joint element for rail	EN AW 6082 aluminium	29 1 1/8	33 1 5/16	340 13 3/8	1	



SLIDING DEVICES | CODES AND DIMENSIONS

CODE	description	material	B [mm] [in]	H [mm] [in]	L [mm] [in]	pcs	
RAILSLIDE	sliding device	AISI 304 stainless steel grade 1.4301	50 1 15/16	50 1 15/16	70 2 3/4	1	
RAILSLIDEA4	A4 sliding device	AISI 316 stainless steel grade 1.4401					
RAILSLIDEOH	sliding device for overhead applications and rope access work	AISI 304 stainless steel grade 1.4301	70 2 3/4	72 2 13/16	95 3 3/4	1	
RAILSLIDEOHA4	A4 sliding device for overhead applications and rope access work	AISI 316 stainless steel grade 1.4401					

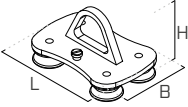
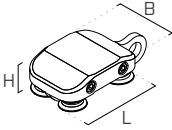
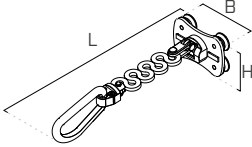
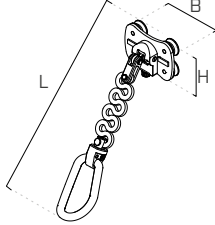
SLIDING DEVICES | CODES AND DIMENSIONS

CODE	description	material	B [mm] [in]	H [mm] [in]	L [mm] [in]	pcs	
RAILSLIDEWALL	sliding device for wall application	AISI 304 stainless steel grade 1.4301	69 2 3/4	73 2 13/16	111 4 3/8	1	
RAILSLIDEWA4	A4 sliding device for wall application	AISI 316 stainless steel grade 1.4401					
RAILSLIDERA	sliding device for wall application and rope access work	AISI 304 stainless steel grade 1.4301 EN AW 6082 aluminium	70 2 3/4	43 1 11/16	151 5 15/16	1	
RAILSLIDERA4	A4 sliding device for wall application and rope access work	AISI 316 stainless steel grade 1.4401 EN AW 6082 aluminium					
RAILSLIDEV	sliding device for vertical application	AISI 304 stainless steel grade 1.4301	110 4 3/8	73 2 7/8	355 14	1	
RAILSLIDEVA4	sliding device in A4 for vertical application	AISI 316 stainless steel grade 1.4401					
RAILSLIDEVH	sliding device for combined vertical and horizontal application	AISI 304 stainless steel grade 1.4301	-	-	-	1	
RAILSLIDEVHA4	sliding device in A4 for combined vertical and horizontal application	AISI 316 stainless steel grade 1.4401					

FASTENERS | CODES AND DIMENSIONS

CODE	description	material	d ₁ [mm] [in]	B [mm] [in]	H [mm] [in]	L [mm] [in]	pcs		
RAILOCKSCREW	screw for RAILBRAT with knurled head for rail clamping	A1-70 stainless steel	20 0.79	-	14 9/16	-	-	1	
RAILSCREW	fastening screws for RAILJUN, RAILEND and RAILENDOPEN DIN 7991 M8 x 16 A2-70	A2-70 stainless steel	8 0.31	-	16 5/8	-	-	50	
RAILSCREWA4	fastening screws for RAILJUN, RAILEND and RAILENDOPEN DIN 7991 M8 x 16 A4-70	A4-70 stainless steel							

H-RAIL | components

EXIT RAILS | CODES AND DIMENSIONS

CODE	description	material	pcs
RAILVEX	straight exit rail for vertical installation on ladder	AISI 304 stainless steel grade 1.4301 EN AW 6063 aluminium	1
RAILVEXC90	90° curved exit rail for vertical installation on ladder	AISI 304 stainless steel grade 1.4301 EN AW 6063 aluminium	1
RAILVEXTEMP	removable exit rail for vertical installation on ladder	AISI 304 stainless steel grade 1.4301 EN AW 6063 aluminium	1

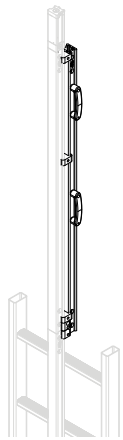
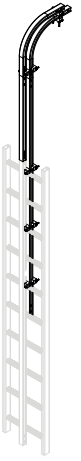
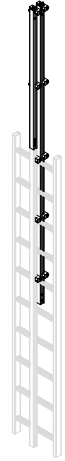

REST | CODES AND DIMENSIONS

CODE	description	material	pcs
RAILVREST	rest board for vertical installation on ladder	AISI 304 stainless steel grade 1.4301	1

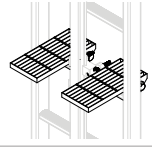

ACCESSORIES | CODES AND DIMENSIONS

CODE	description	material	B [mm] [in]	H [mm] [in]	L [mm] [in]	pcs
RAILJUNTOOL	template for rail junction holes	EN AW 6082 1.1191 (C45E) aluminium AISI 304 stainless steel grade 1.4301	92 3 5/8	116 4 9/16	132 5 3/16	1
RAILPLATE	identification plate for H-RAIL (languages: Italian, English, German, French, Spanish)	-	40 1 9/16	140 5 1/2	- -	1
RAILPLATEBS	identification plate for H-RAIL according to British standards (languages: Italian, English, German, French, Spanish)	-	41 1 5/8	285 11 1/4	- -	1
RAILVPLATE	identification plate for vertical installation on ladder	-	- -	- -	- -	1

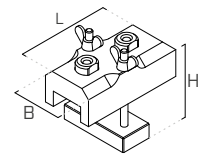

INFORMATION PLATES | CODES AND DIMENSIONS

CODE	description	material	pcs
TARGA _{xy} *	information plate for fall protection systems	stainless steel (AISI 304), plastic	1
TARGAHOR _{xy} *	information plate for PATROL and H-RAIL	stainless steel (AISI 304), plastic	1

*xy represents the ISO 639-1 language code, see the table below for reference.



EXAMPLE:

TARGAEN	information plate for fall protection systems in EN (English)
TARGAHOREN	information plate for PATROL and H-RAIL in EN (English)
TARGAVERT EN	information plate for VERTIGRIP in EN (English)

VERTIGRIP

VERTICAL LIFELINE

SLIDING DEVICE

	VERTSLIDEPAS	VERTSLIDE
	 <p>removable sliding through fall arrest device with stainless steel energy absorber</p>	 <p>removable sliding fall arrest device made entirely of stainless steel with energy absorber for vertical lifeline</p>
standard	EN 353-1:2014 + A1:2017	EN 353-1:2014 + A1:2017
absorber	stainless steel	fabric
types	through	semi-automatic
cable diameter	8 mm	8 mm
dimensions	190 x 90 x 28 mm	150 x 80 x 25 mm
weight	1030 g	455 g
type of closure	3-step self-locking gate	screw ring nut

ANCHOR POINT EN 795 A FOR ACCESS TO ROOF

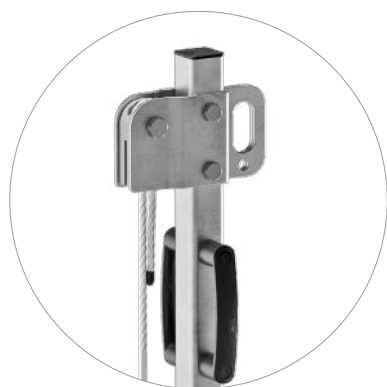

VERTOP17

anchor EN 795 Type A on VERTOP17
end element of VERTIGRIP

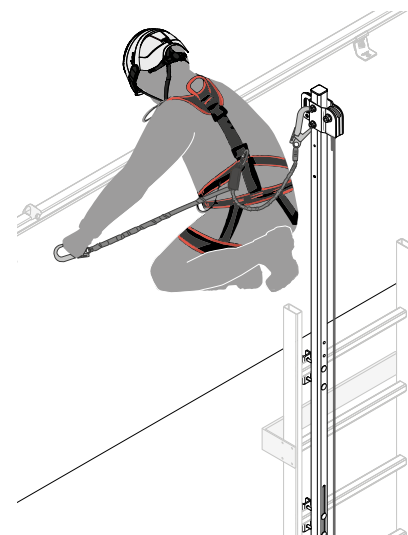
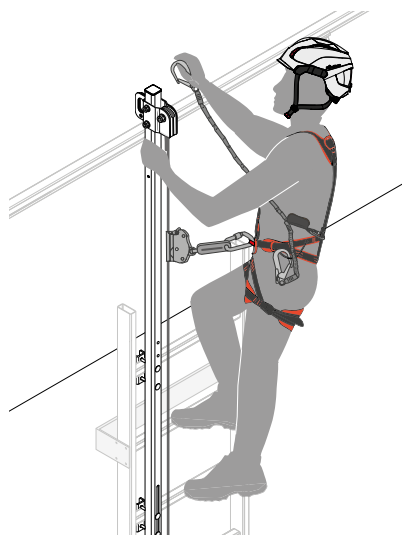

VERTIGRIP | ELEMENTS AND INTERMEDIATE ELEMENTS

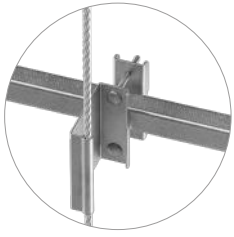

**VERTPAS
VERTPASA4**

fixed pass-through
intermediate for vertical
lifeline

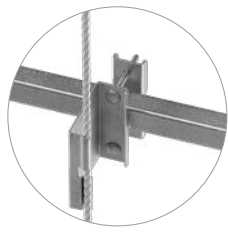

**VERTPASR
VERTPASRA4**

removable intermediate
element for vertical
lifeline

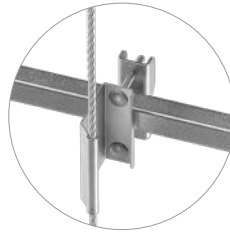

**VERTPAS45
VERTPAS45A4**

fixed pass-through
intermediate element
for vertical lifeline,
designed for side
installation

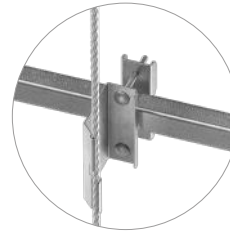

**VERTPASR45
VERTPASR45A4**

removable pass-through
intermediate element for
vertical lifeline, designed
for side installation

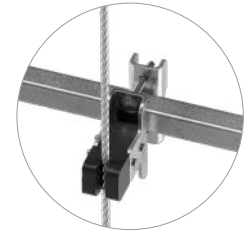

VERTINT

semi-automatic
intermediate anchor
for vertical lifeline,
designed for installation
on ladder

PASS-THROUGH SYSTEM

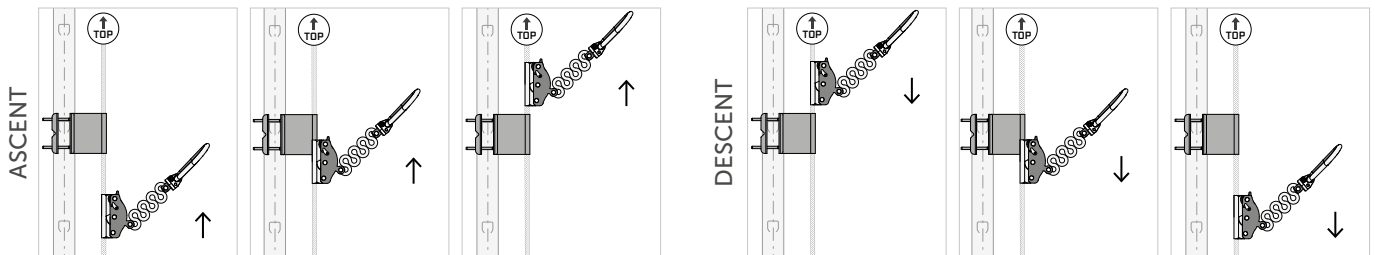

The VERTSLIDEPAS shuttle allows full automatic passage over the intermediate element of the VERTIGRIP vertical lifeline. Moreover, its energy absorber, made entirely of metal, offers unlimited durability, although annual maintenance is required.

SEMI-AUTOMATIC SYSTEM

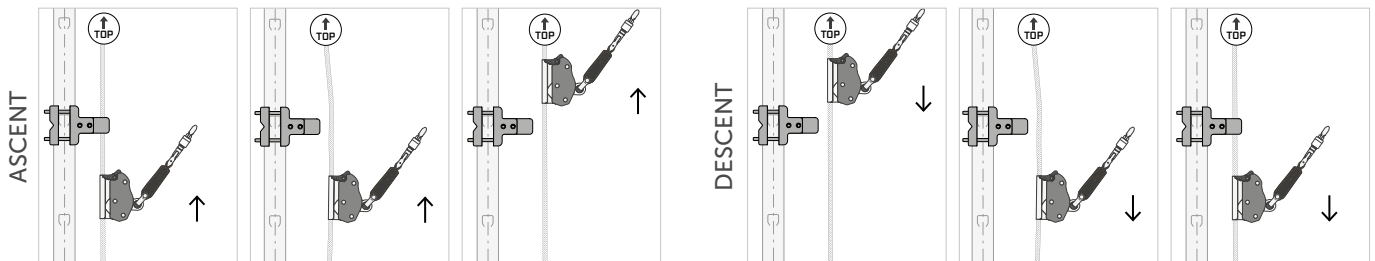

The VERTSLIDE shuttle allows semi-automatic passage over the intermediate elements. During ascent and descent in safe conditions on the VERTIGRIP system, the operator must disconnect the cable from VERTINT or VERTINTW to pass the intermediate elements, then reconnect it to the end element. This is a simple, easy procedure.

INSTALLATION ON STRUCTURE

The wall supports allow installation on various façade substructures (timber, steel, concrete) and can be combined with the ladder supports.



**VERTBASEW
VERTBASEWA4**

lower support for vertical lifeline
on structure



**VERTINTW
VERTINTWA4**

intermediate element for vertical lifeline
on structure



**VERTOPW
VERTOPWA4**

upper support for vertical lifeline
on structure

VERTIGRIP ON LADDER



VERTICAL LIFELINE ON LADDERS

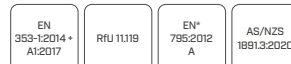

*only for VERTOP17, VERTOP09, VERTOP17A4, VERTOP09A4

STRONG

Complete system in AISI 316 stainless steel - AISI 304 stainless steel - EN AW 6082 aluminium alloy, guarantees excellent corrosion resistance.



FUNCTIONAL

Guided type fall arrester on rope with integrated energy absorber, which allows a controlled ascent and descent in safe conditions.

MAXIMUM NUMBER OF USERS



PRACTICAL

The system can be assembled off-centre on the ladder.

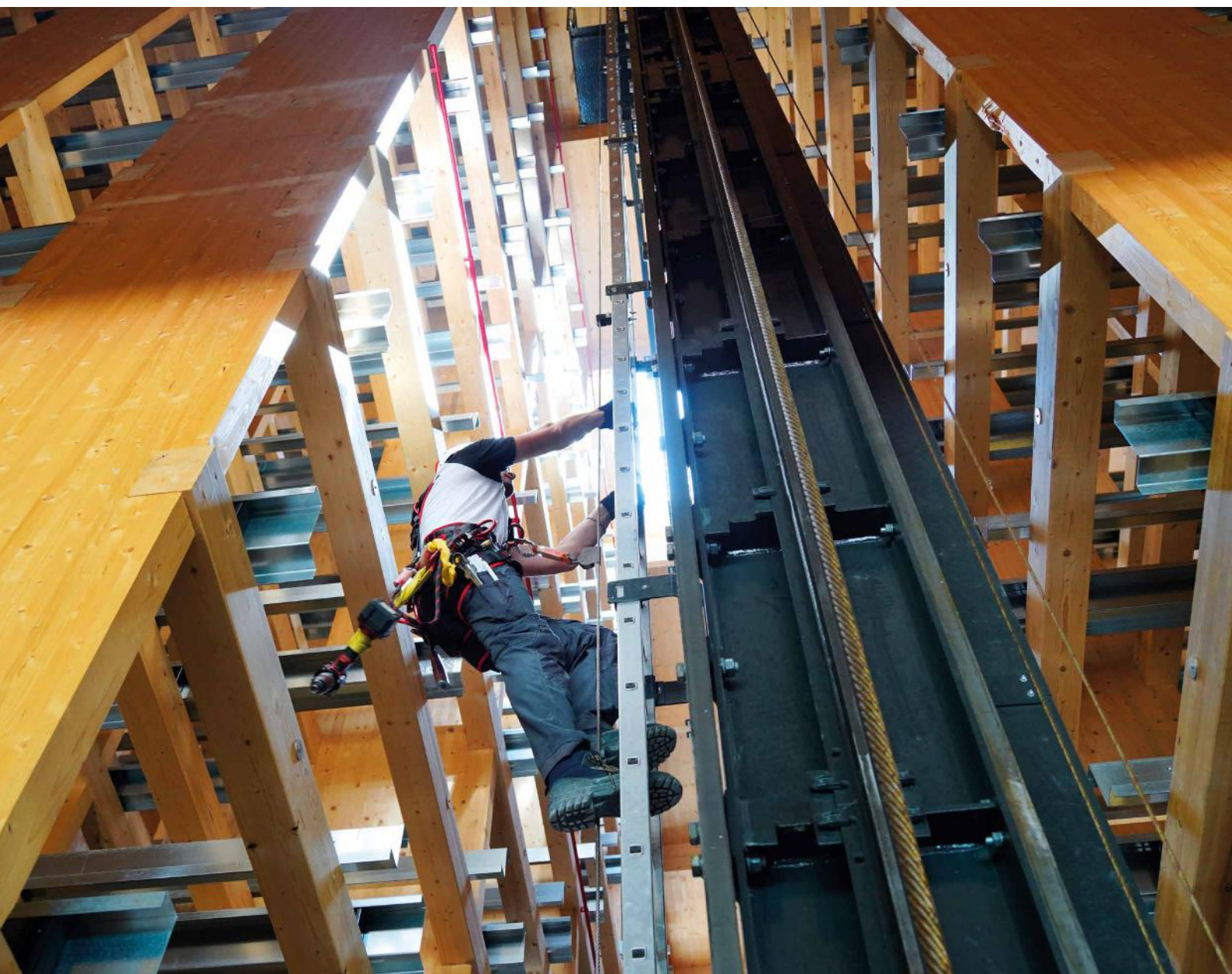
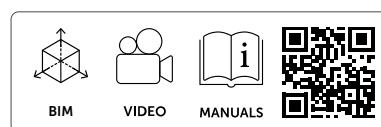

TECHNICAL DATA*

VERTICAL LIFELINE COMPONENTS

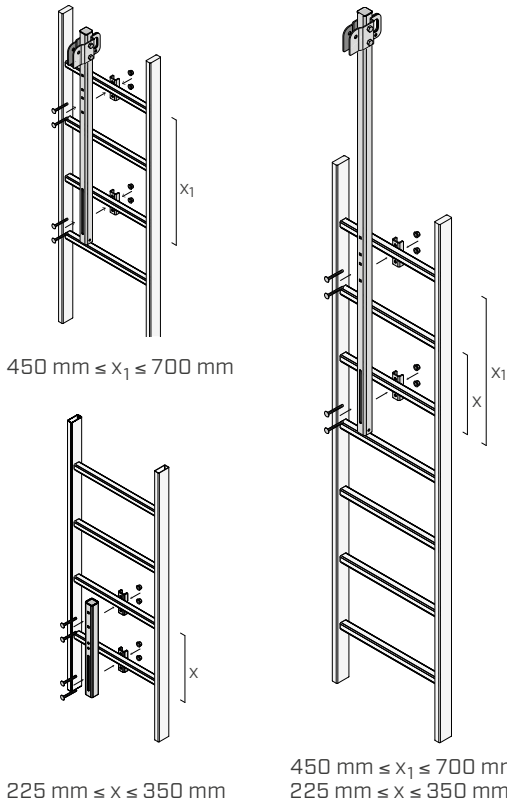
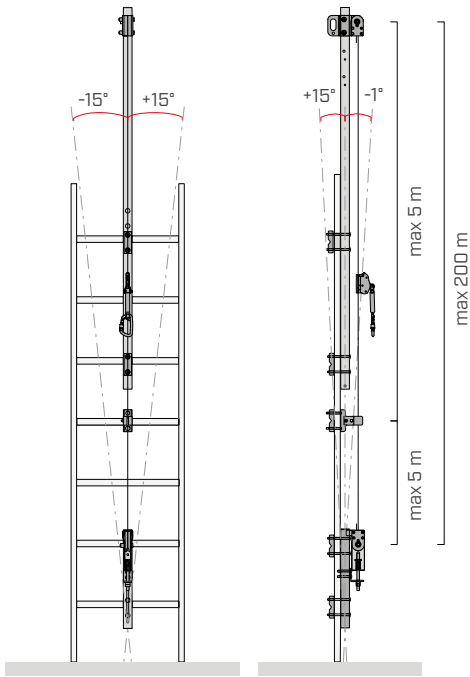

* The values indicated are the result of experimental tests carried out under the supervision of third parties in accordance with the standard referred to. For a correct calculation report with minimum distances according to the standard requirements, the substructure must be checked by a qualified engineer before installation.

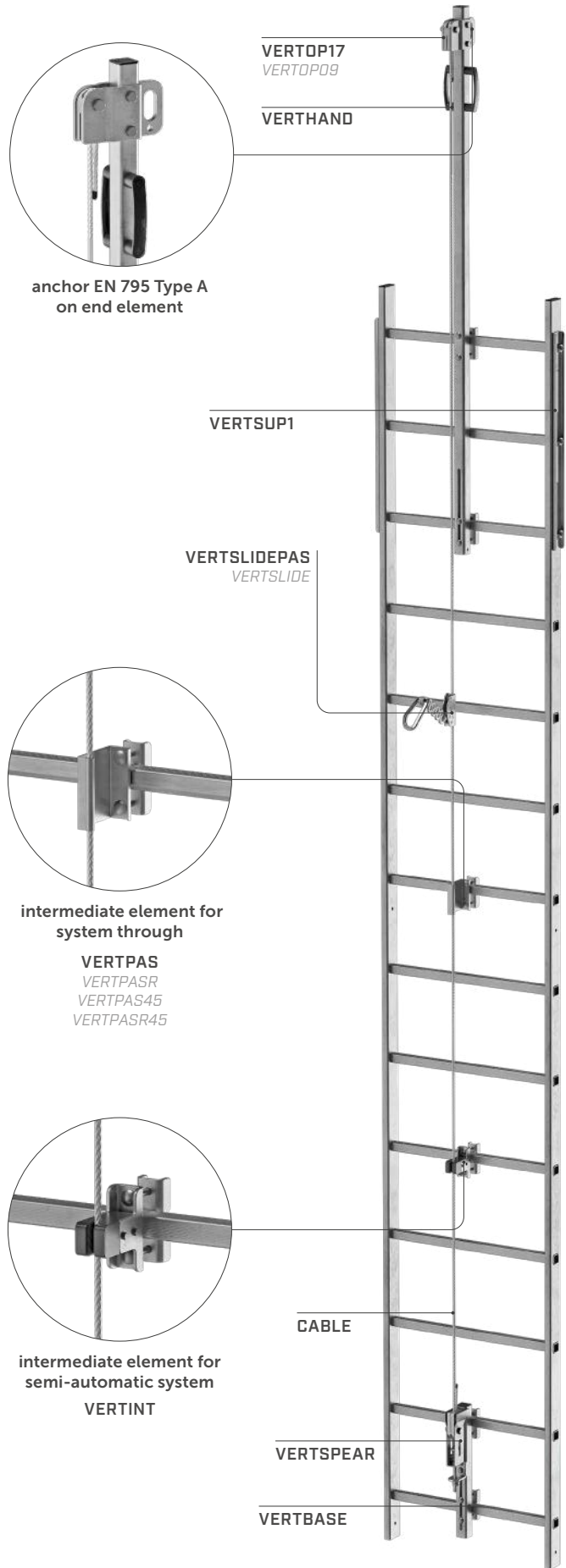
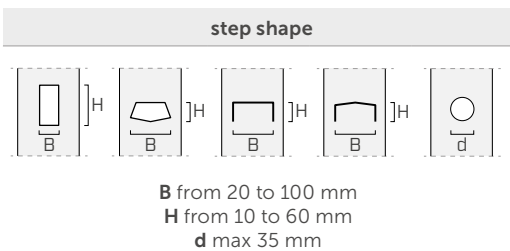

NOTE:
For versions in A4, see the page on components (see page 90).

VERTIGRIP ON WALL



VERTICAL LIFELINE ON WALL

PRACTICAL

The special-purpose supports allow installation on substructures in CLT, concrete or steel.

ADJUSTABLE

Possibility of adjusting the distance of the lifeline from the wall.

FUNCTIONAL

It can be installed on walls inclined at an angle of up to 15° from the vertical.

EN 353-1:2014 + A1:2017

RFU 11.119







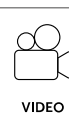
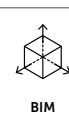

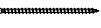

AS/NZS 1891.3:2020



MAXIMUM NUMBER OF USERS



TECHNICAL DATA*

substructure	minimum thickness	fasteners
 CLT	100 mm	VGS Ø11 
 C20/25	140 mm	AB1 Ø12 AB1A4 
		SKR Ø12  rod Ø12 
		VIN-FIX  HYB-FIX 
 S235JR	6 mm	EKS + ULS  + MUT 

VERTICAL LIFELINE COMPONENTS

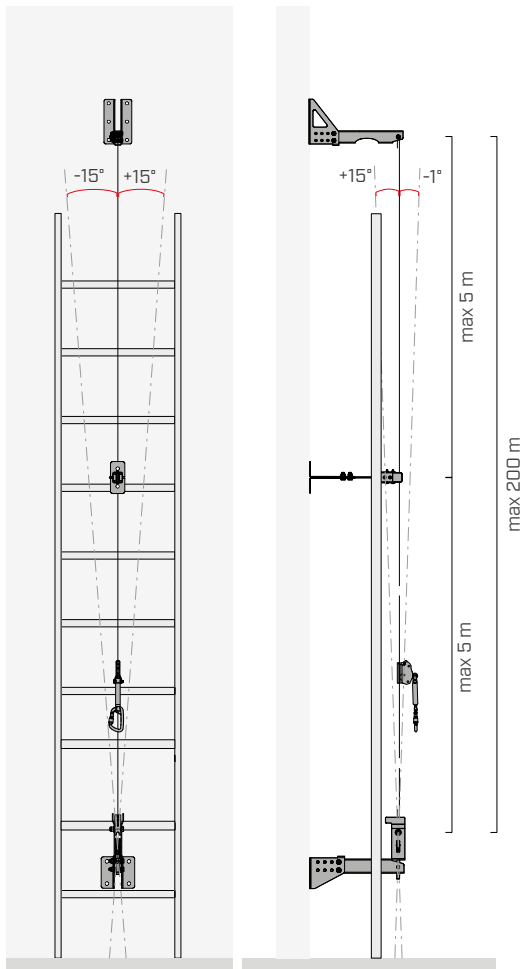

intermediate element for semi-automatic system

VERTINTW

VERTSPEAR

VERTBASEW

* The values indicated are derived from experimental tests carried out under the supervision of third party organisations according to the referenced standard. For a calculation report with minimum distances, according to the referenced normative requirements, the substructure must be verified by a qualified engineer before installation.

A4
AISI 316

NOTE:

For versions in A4, see the page on components (see page 90).

VERTIGRIP | combinations

PASS-THROUGH SYSTEM

CENTRAL ASSEMBLY

SIDE ASSEMBLY

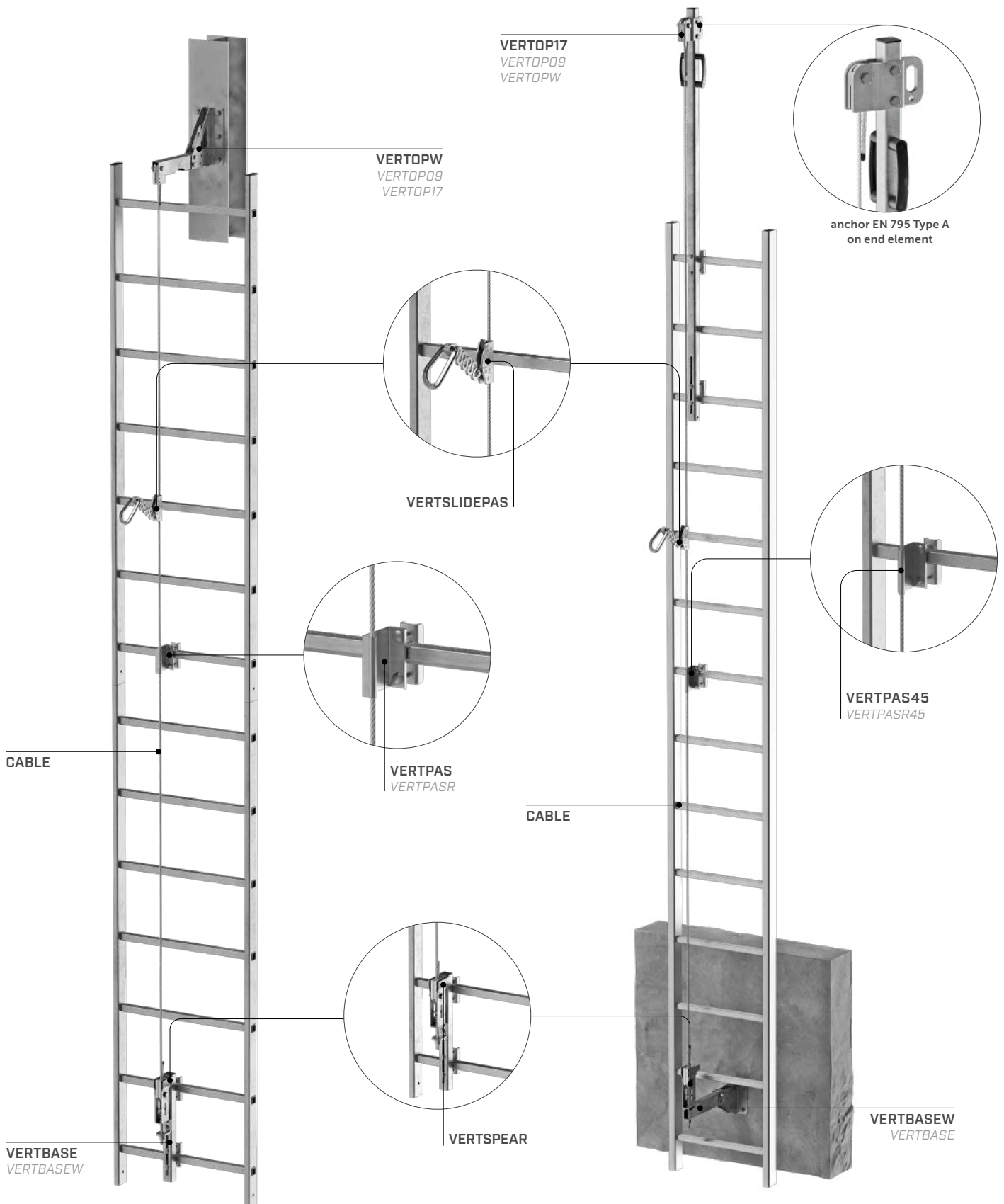

A4
AISI 316

NOTE:
For versions in A4, see the page on components (see page 90).

SEMI-AUTOMATIC SYSTEM

CENTRAL ASSEMBLY

SIDE ASSEMBLY

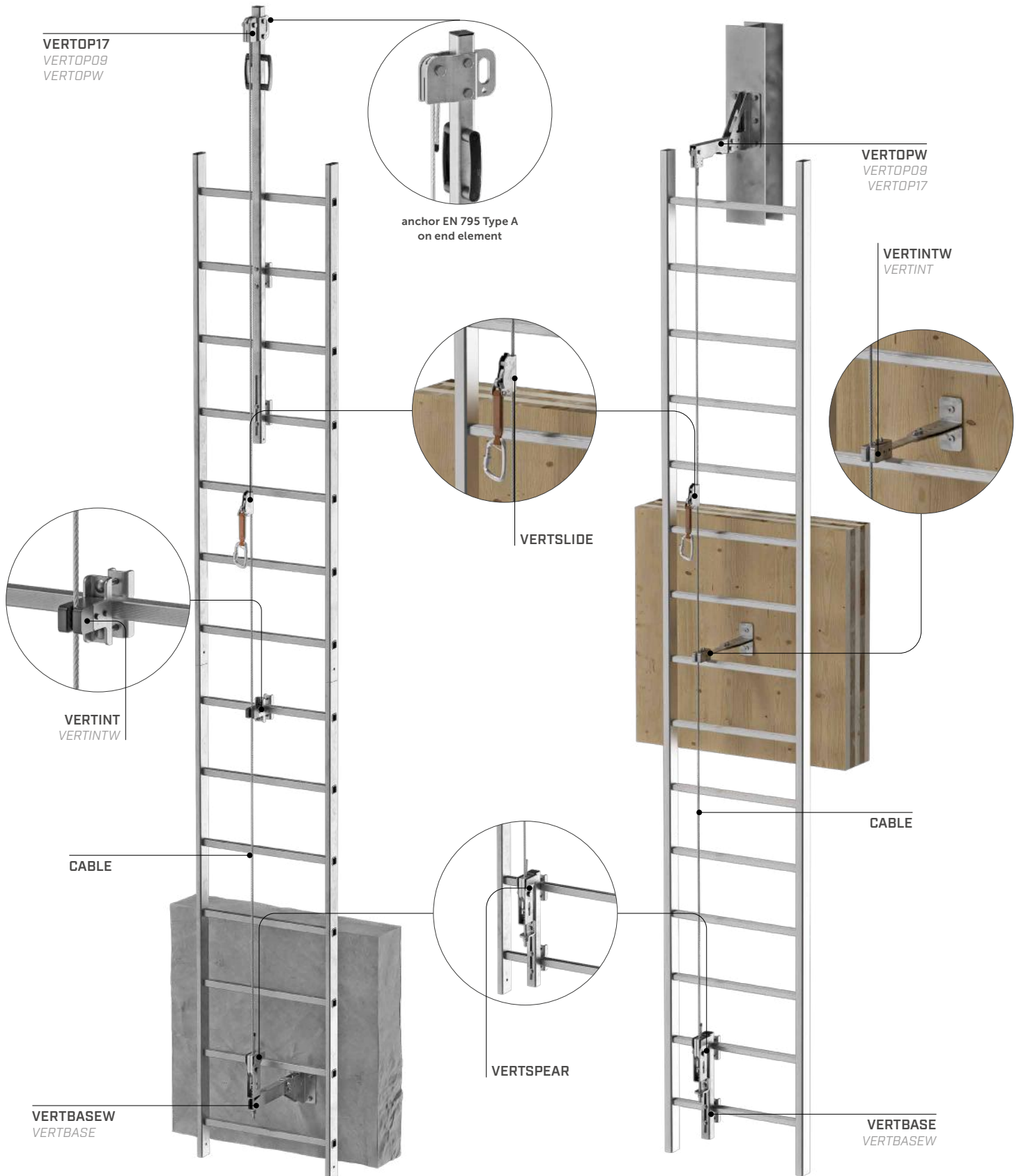









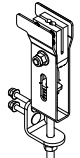

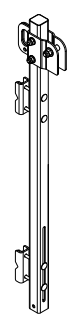
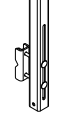
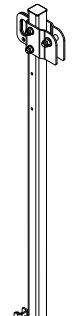

A4
AISI 316

NOTE:
For versions in A4, see the page on components (see page 90).

VERTIGRIP | components

MAIN COMPONENTS OF THE VERTICAL LIFELINE

GROUP	CODE	description	material	weight [kg]	pcs	
TENSIONER	VERTSPEAR	set for clamps and tensioner	AISI 304 stainless steel grade 1.4301 EN AW 6082 aluminium	2,60	1	
	VERTSPEARA4	set for clamps and tensioner in A4	AISI 316 stainless steel grade 1.4401			
ROPE	CABLE	stainless steel rope AISI 316 Ø8 mm 7 x 7	stainless steel AISI 316	0,259	1	
GUIDED TYPE FALL ARRESTER	VERTSLIDE	removable sliding fall protection device with energy absorber	AISI 304 stainless steel grade 1.4301 EN AW 7075 T6 aluminium alloy	0,465	1	
	VERTSLIDEPAS	removable sliding through fall arrest device with energy absorber	AISI 304 stainless steel grade 1.4301	0,97	1	
UPPER SUPPORT	VERTOP09	upper support (0.9 m) for ladder with anchor point	AISI 304 stainless steel grade 1.4301	4,44	1	
	VERTOP09A4	upper support (0.9 m) in A4 for ladder with anchor point	AISI 316 stainless steel grade 1.4401			
	VERTOP17	upper support (1.7 m) for ladder with anchor point	AISI 304 stainless steel grade 1.4301	8,73	1	
	VERTOP17A4	upper support (1.7 m) in A4 for ladder with anchor point	AISI 316 stainless steel grade 1.4401			

GROUP	CODE	description	material	weight [kg]	pcs	
LOWER SUPPORT	VERTBASE	lower support for ladder	AISI 304 stainless steel grade 1.4301	1,98	1	
	VERTBASEA4	A4 lower support for ladder	AISI 316 stainless steel grade 1.4401			
INTERMEDIATE SUPPORT*	VERTINT	intermediate support for ladder	AISI 304 stainless steel grade 1.4301 - ABS	0,74	1	
	VERTINTA4	A4 intermediate support for ladder	AISI 316 stainless steel grade 1.4401 - ABS			
	VERTPAS	fixed pass-through intermediate support for ladder	AISI 304 stainless steel grade 1.4301	0,44	1	
	VERTPASA4	A4 fixed pass-through intermediate support for ladder	AISI 316 stainless steel grade 1.4401			
	VERTPASR	removable pass-through intermediate support for ladder	AISI 304 stainless steel grade 1.4301	0,42	1	
	VERTPASRA4	A4 removable pass-through intermediate support for ladder	AISI 316 stainless steel grade 1.4401			
	VERTPAS45	side fixed pass-through intermediate support for ladder	AISI 304 stainless steel grade 1.4301	0,42	1	
	VERTPAS45A4	side fixed pass-through intermediate support in A4 for ladder	AISI 316 stainless steel grade 1.4401			
	VERTPASR45	side removable pass-through intermediate support for ladder	AISI 304 stainless steel grade 1.4301	0,40	1	
	VERTPASR45A4	side removable pass-through intermediate support in A4 for ladder	AISI 316 stainless steel grade 1.4401			

*Recommended every 5 meters.

■ SUPPORT FOR VERTICAL LIFELINE ON STRUCTURE

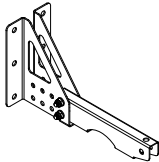
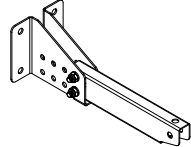
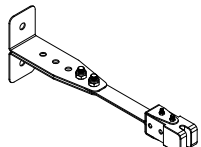
GROUP	CODE	description	material	weight [kg]	pcs	
UPPER SUPPORT	VERTOPW	upper support for structure	AISI 304 stainless steel grade 1.4301	2,38	1	
	VERTOPWA4	A4 upper support for structure	AISI 316 stainless steel grade 1.4401			
LOWER SUPPORT	VERTBASEW	lower support for structure	AISI 304 stainless steel grade 1.4301	1,94	1	
	VERTBASEWA4	A4 lower support for structure	AISI 316 stainless steel grade 1.4401			
INTERMEDIATE SUPPORT*	VERTINTW	intermediate support for structure	AISI 304 stainless steel grade 1.4301 - ABS	1,26	1	
	VERTINTWA4	A4 intermediate support for structure	AISI 316 stainless steel grade 1.4401 - ABS			

*Recommended every 5 meters.

VERTIGRIP | components

VERTICAL LIFELINE ACCESSORIES

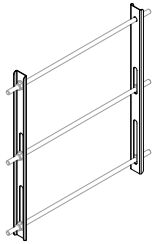
GROUP	CODE	description	material	weight [kg]	pcs	
HANDLE	VERTHAND	set of handles for VERTOP17	PA6 - AISI 304 stainless steel grade 1.4301	0,14	1	
LADDER REINFORCEMENT	VERTSUP1	additional reinforcement set for ladder*	AISI 304 stainless steel grade 1.4301	1,48	1	

*Threaded bars, nuts and washers not included in the set.

INFORMATION PLATES | CODES AND DIMENSIONS

CODE	description	material	pcs
TARGA _{xy} *	information plate for fall protection systems	stainless steel (AISI 304), plastic	1
TARGAHOR _{xy} *	information plate for PATROL and H-RAIL	stainless steel (AISI 304), plastic	1
TARGAVERT _{xy} *	information plate for VERTIGRIP	stainless steel (AISI 304), plastic	1

*xy represents the ISO 639-1 language code, see the table below for reference.

EXAMPLE:

TARGAEN information plate for fall protection systems in EN (English)
TARGAHOREN information plate for PATROL and H-RAIL in EN (English)
TARGAVERTEN information plate for VERTIGRIP in EN (English)



We test your safety, so you don't have to

At "Laboratorio Gravità", our in-house testing facility, we rigorously test vertical and horizontal fall protection systems, including fastenings. Our CE-certified test bench speeds up product development and ensures that every fall protection system undergoes strict testing before reaching the market.

rothoblaas.com/safe



 **rothoblaas**

Solutions for Safety

GREEN LINE

LIFELINE ON BALLASTED SUPPORTS

FUNCTIONAL

System with ballast that does not require the roofing to be penetrated. It avoids thermal bridging and respects the waterproofing of the structure.

FAST INSTALLATION

The system consists of few components which facilitate and speeds up mounting.

LOW PROFILE

System with reduced visual impact, almost invisible once installed.

EN 795:2012 C
CEN/TS 16415:2013



LOAD DIRECTION



TYPES OF APPLICATION



PATROL LIFELINE COMPONENTS

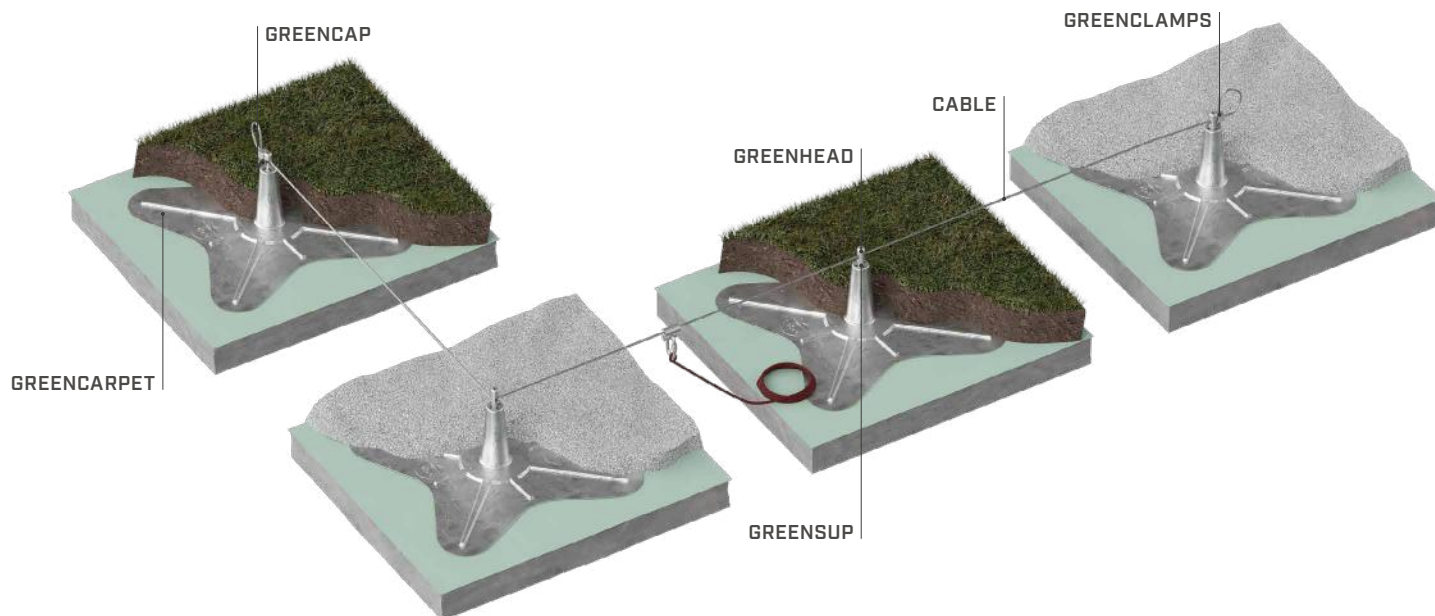

TECHNICAL DATA



			GREEN LINE		
			EN 795:2012 C	CEN/TS 16415:2013	UNI 11578:2015 C
minimum span	x_{min}	[m]	1,5		
maximum span	x_{max}	[m]	8		
maximum deflection	y_{max}	[m]	2,45		

		system characteristics	
ballast support dimensions	[cm]	300 x 300 ($\pm 5\%$) x 30 ($\pm 1\%$)	
support for ballast		glass-fibre reinforced plastic cone with laminated ballast mat (frost-resistant)	
distance between supports	[m]	1,5 - 8	
minimum weight of material for ballast*	[kg/m ²]	80	
steel rope type	[mm]	Ø8 (7 x 19)	
durability		weatherproof (UV-resistant, it can be used in frost and heat)	

* if an additional mat is used: 30 kg/m². All technical data are average values.

They are based on measurements from various test institutes and measurement laboratories. We reserve the right to make technical changes

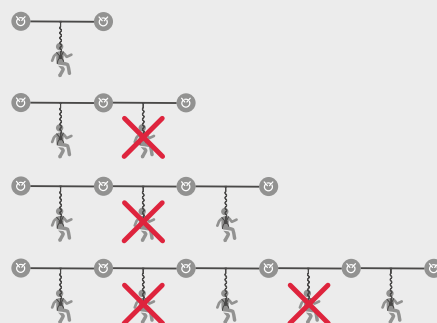

NUMBER OF USERS

Unlimited. Each operator working on one span must have at least both spans beside it free of operators. See diagram aside.

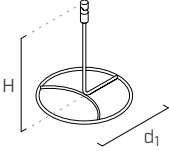
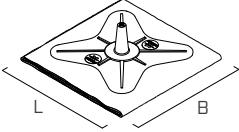
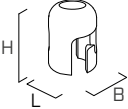
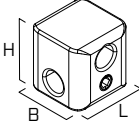

GREEN LINE | components

CODES AND DIMENSIONS

CODE	description	material	d ₁ [mm] [in]	B [mm] [in]	H [mm] [in]	L [mm] [in]	s [mm] [in]	pcs	
GREENSUP	internal part for support	AISI 316L stainless steel grade 1.4404	250 9.84	-	300 11 3/4	-	-	1	
GREENCARPET	tarpaulin with possibility of installing ballasts 3 x 3 m with external cone	glass fibre reinforced plastic (GFRP)	-	3000 118 1/8	-	3000 118 1/8	-	1	
GREENHEAD	fastening head	AISI 316 stainless steel grade 1.4408	-	40 1 9/16	57,5 2 5/16	28 1 1/8	-	1	
GREENCLAMPS	set of 2 cable lock clamps	AISI 316 stainless steel grade 1.4408	-	29 1 1/8	29 1 1/8	29 1 1/8	-	1	
CABLE	stainless steel rope Ø8 7x7	AISI 316 stainless steel grade 1.4401	Ø8 Ø0.31	-	-	-	-	1	
GREENCAP	heat shrink tube for CABLE protection	-	Ø8 Ø0.31	-	-	-	-	1	



Complete training

Tailor-made courses for fall protection system designers, installers and maintenance professionals



CLASSROOM TEACHING AND VIDEO COURSES

Comprehensive training programmes covering the most relevant topics in fall protection system design and construction. Not only in the classroom: Rothoschool is also video learning, with in-depth training on our products and solutions.



PRACTICAL TESTS

All Rothoblaas courses combine theory and hands-on training, featuring laboratory simulations to enhance skills through real-world scenarios and direct interaction with our solutions.



ROTHOSCHOOL ON TOUR

Rothoschool courses can be held not only at our headquarters in Italy but also, on request, at a location of your choice. Contact us to organise courses tailored to your needs.

Discover all Rothoschool courses

Keep up to date and discover the right training for a successful professional future!

rothoblaas.com/school



rothoschool

TEMPORARY

TEMPORARY LIFELINE



- Temporary horizontal lifeline, easy to install
- 30 mm high-strength, high-visibility polyester webbing
- Number of users: 2 (1 each span)

MAXIMUM NUMBER OF USERS



CODES AND DIMENSIONS

CODE	description	standard	pcs
TEMP20	temporary lifeline L = 20 m	EN 795:2012 B+C, CEN/TS 16415:2013	1

COMPLEMENTARY PRODUCTS

CODE	description	standard	pcs
OVALSTE	large carabiner	CE - EN 362/M	2



TECHNICAL DATA*

		EN 795:2012 B+C	CEN/TS 16415:2013
maximum users	no.		
users per span	no.		
minimum span	x_{min} [m]	2	
maximum span	x_{max} [m]	20	
minimum deflection	y_{min} [m]	0,3	
maximum deflection	y_{max} [m]	3	
total line length	L_{tot} [m]	20	
minimum resistance on end elements	R_{min} [kN]	21	

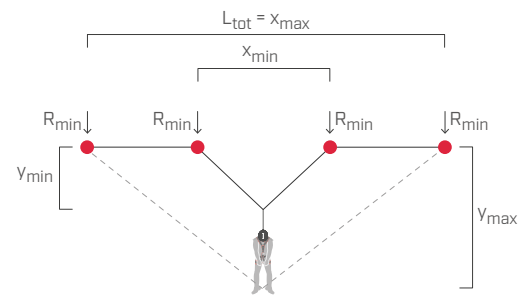

* The values indicated are the result of experimental tests carried out under the supervision of third parties in accordance with the standard referred to. For a correct calculation report with minimum distances according to the standard requirements, the substructure must be checked by a qualified engineer before installation.

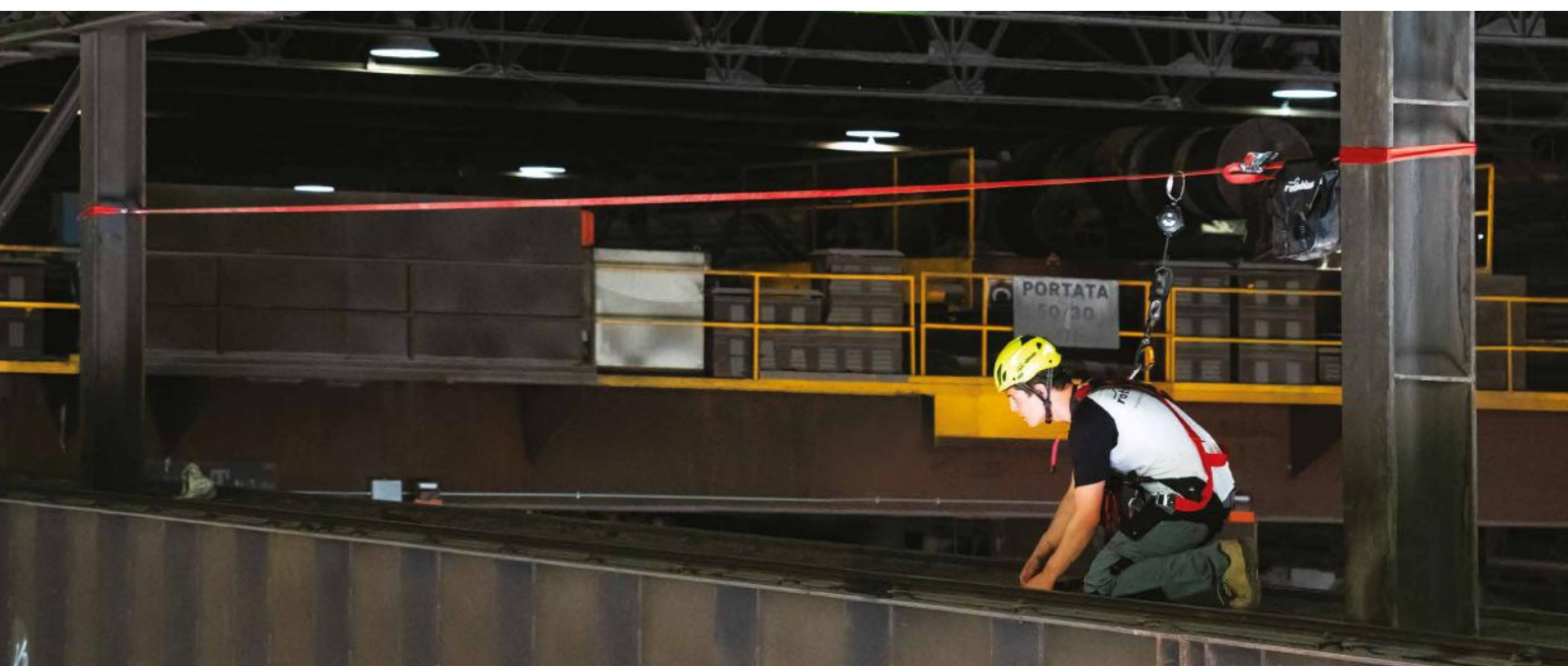

HOLD-SYSTEM®



TEMPORARY HORIZONTAL ANCHORING DEVICE

- Complete system of carabiners and webbing for fastening
- Quick and easy tensioning of the system by one operator using Prusik knot system and self-locking device
- The structure or anchor points to which the system will be installed must withstand a recommended stress of 9 kN

EN 795:2012 B+C	CEN/TS 16415:2013	OSHA 1910 Subpart I App D	OSHA 1926 Subpart M App C
-----------------	-------------------	---------------------------	---------------------------

MAXIMUM NUMBER OF USERS



CODES AND DIMENSIONS

CODE	standard	L [m]	L [ft]	pcs
TEMPLUS20		20	65' 7 3/8"	1
TEMPLUS30	EN 795:2012 B+C	30	98' 5 1/8"	1
TEMPLUS40	CEN/TS 16415:2013	40	131' 2 3/4"	1
TEMPLUS60	OSHA 1910 Subpart I App D	60	196' 10 1/4"	1
TEMPLUS80	OSHA 1926 Subpart M App C	80	262' 5 5/8"	1

COMPLEMENTARY PRODUCTS

CODE	description	L [m]	L [ft]	pcs
HSG2RB	retractable webbing device EN 360	2	6' 6 3/4"	1
TEMPLUSLAN	adjustable polyester lanyard with EN 795 Type B certification	2	6' 6 3/4"	1



TEMPLUS20



TEMPLUSLAN



HSG2RB

TECHNICAL DATA*

		EN 795:2012 B+C	CEN/TS 16415:2013	OSHA 1910 Subpart I App D	OSHA 1926 Subpart M App C
maximum users	no.	👤👤			
users per span	no.	👤			
minimum span	x_{min} [m]	5			
maximum span	x_{max} [m]	15			
minimum deflection	y_{min} [m]	0,7			
maximum deflection	y_{max} [m]	1,5			
total line length	L_{tot} [m]	20-80			
minimum resistance on end elements	R_{min} [kN]	9			

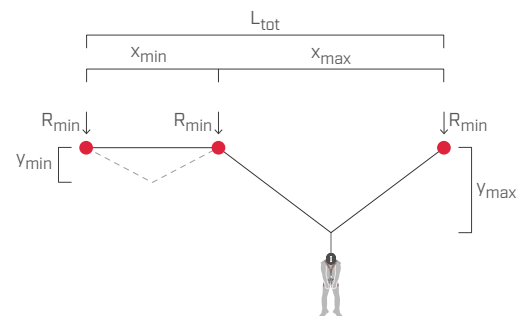

* The values indicated are the result of experimental tests carried out under the supervision of third parties in accordance with the standard referred to. For a correct calculation report with minimum distances according to the standard requirements, the substructure must be checked by a qualified engineer before installation.

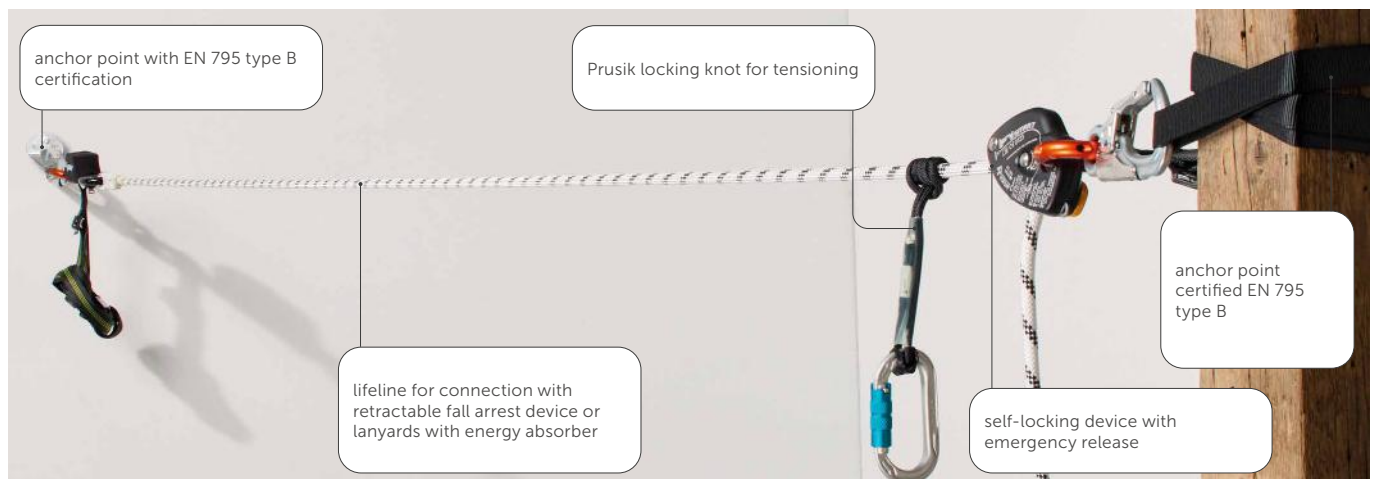

The use of other retractable devices is permitted, provided the original manufacturer's instructions are followed.

ANCHOR POINTS

THE RIGHT ANCHOR POINT FOR EACH STRUCTURE

TIMBER



WING

page 104 ◀



SOLID

page 110 ◀



LOOP

page 112 ◀



HOOK SPIKE

page 113 ◀



HOOK EVO

page 114 ◀



HOOK EVO 2.0

page 115 ◀



SLIM

page 116 ◀



KITE

page 117 ◀



AOS

page 119 ◀



AOS01 + TOWER/TOWERA2

page 120 ◀



AOS01 + TOWER XL

page 121 ◀



RAPTOR

page 133 ◀

STEEL



WING

page 104 ◀



AOSWS

page 106 ◀



CORNER

page 107 ◀



SOLID

page 110 ◀



KITE

page 117 ◀



AOS

page 119 ◀



AOS01 + TOWER/TOWERA2

page 120 ◀



MOBILE

page 130 ◀



ROD

page 131 ◀



CARRIER

page 132 ◀



WING
page 104 ◀



AOSWS
page 106 ◀



CORNER
page 107 ◀



SOLID
page 110 ◀



LOOP
page 112 ◀



HOOK EVO 2.0
page 115 ◀



KITE
page 117 ◀



AOS
page 119 ◀



AOS01 + TOWER/TOWERA2
page 120 ◀



AOS01 + TOWER XL
page 121 ◀



SIANK
page 118 ◀



AOS01 + TOWER XL
page 121 ◀



AOS01 + T-CLAMP
page 122 ◀

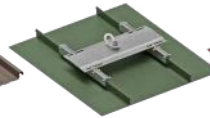

AOS01 + COPPO
page 126 ◀



AOS01 + SHIELD
page 123 ◀



AOS01 + SHIELD 2
page 124 ◀

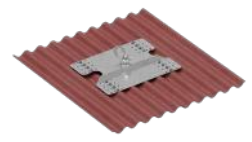

AOS01 + WAVE
page 125 ◀



C-LEVER
page 108 ◀



AOS01 + BLOCK
page 127 ◀



GREEN POINT
page 128 ◀



GLUE ANCHOR
page 129 ◀

WING

ANCHOR POINT FOR ROPE ACCESS WORK

VERSATILE

Suitable for both rope access work and fall protection.

SOLID

Extremely robust and reliable.

ADAPTABLE

Available in two materials and three different colours, WING adapts to the main types of substrates, all applications and any weather conditions, even the most severe.

EN 795:2012 A	CEN/TS 18415:2013	UNI 11578:2015 A	ANSI Z359.18/A	AS/NZS 1891.4:2009	AS/NZS 5532:2013	SK TP -23/0002
---------------------	----------------------	------------------------	-------------------	-----------------------	---------------------	-------------------



MAXIMUM NUMBER
OF USERS



LOAD DIRECTION



TYPES OF
APPLICATION



▼ WING anchor points installed for rope access work during maintenance of a church dome.

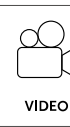
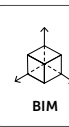

FIELDS OF APPLICATION

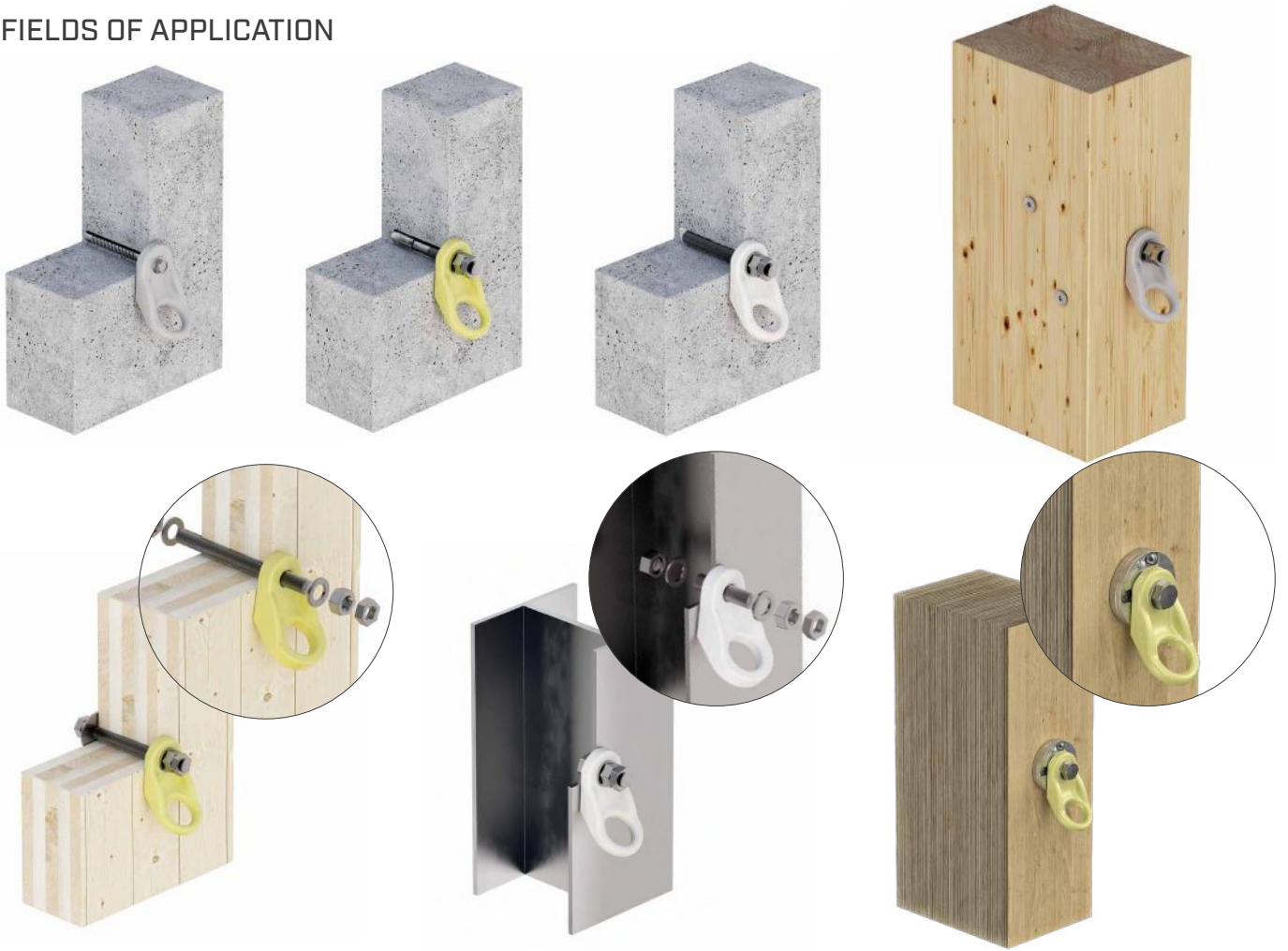

TECHNICAL DATA*

substructure	minimum thickness	fasteners	substructure	minimum thickness	fasteners
GL24h	100 x 160 mm	VGS Ø11	C20/25	158 mm	AB1 Ø16 ABEA4 Ø16
		XEPOX F M16 rod + MUT + ULS			M16 + ULS + MUT (8.8/A2/A4)
CLT	100 mm	8.8 Ø16 rod + MUT + ULS			VIN-FIX HYB-FIX
LVL	300 mm	DISC FLAT + LBS Ø7 min 100 mm, DIN 137 D16 B, DIN 933 M16x30			SKR CE Ø16
			S235JR	5 mm	EKS M16 + MUT + ULS (8.8/A2/A4)

* The values indicated are the result of experimental tests carried out under the supervision of third parties in accordance with the standards referred to. For a correct calculation report with minimum distances according to the standard requirements, the substructure must be checked by a qualified engineer before installation.

CODES AND DIMENSIONS

CODE	material	colour		d ₁ [mm] [in]	B [mm] [in]	H [mm] [in]	L [mm] [in]	pcs	
WING	S355J2 - zinc plated Fe/Zn 12µ + powder coated (RAL7032-grey)			17	65	56	115	1	
WINGY	S355J2 - zinc plated Fe/Zn 12µ + powder coated (RAL1016-yellow)			0.67	2 9/16	2 3/16	4 1/2		
WINGA4	AISI 316L stainless steel grade 1.4404			17	65	56	115	1	

AOSWS

ANCHOR POINT FOR WORK AT HEIGHT

UNIVERSAL

It can be used both for the safety rope in rope access work, and for fall protection works.

FUNCTIONAL

Compact with anchor point up to three users.

VERSATILE

Certified for use on different substructures and with different fastening systems.

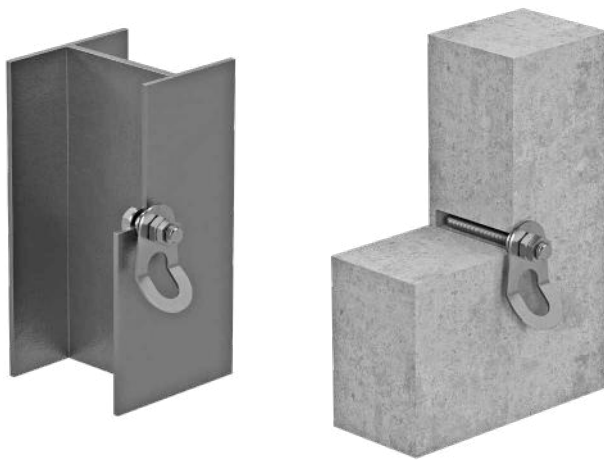

EN 795:2012 A	CEN/TS 18418:2013	UNI 11578:2015 A
---------------------	----------------------	------------------------



MAXIMUM NUMBER OF USERS



LOAD DIRECTION



TYPES OF APPLICATION

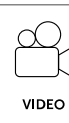

TECHNICAL DATA*

substructure	minimum thickness	substructure	minimum thickness	fasteners
S235JR	5 mm	C20/25	170 mm	AB1/ABEA4 VIN-FIX

* The values indicated are the result of experimental tests carried out under the supervision of third parties in accordance with the standard referred to. For a calculation report with minimum distances according to the relevant standard requirements, the substructure must be checked by a qualified engineer before installation.

CODES AND DIMENSIONS

CODE	material		d ₁ [mm] [in]	B [mm] [in]	L [mm] [in]	pcs	
AOSWS	AISI 304 stainless steel grade 1.4301		17 0.67	60 2 3/8	98 3 7/8	1	
AOSWSA4	AISI 316 stainless steel grade 1.4401		17 0.67	60 2 3/8	98 3 7/8	1	

CORNER

ANCHOR POINT FOR WORK AT HEIGHT

LOW PROFILE

Very compact device that provides a safe anchor point for a single worker.

PRACTICAL

Its lightweight design makes it ideal as an anchor point for the safety rope during rope access work.

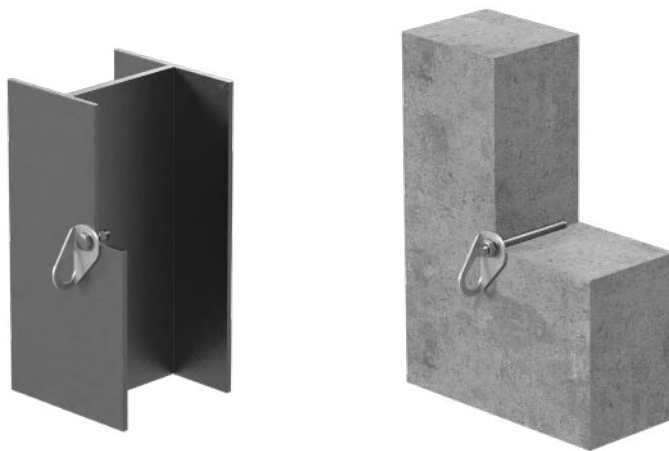

EN
795:2012
A



MAXIMUM NUMBER
OF USERS



LOAD DIRECTION



TYPES OF
APPLICATION



CODES AND DIMENSIONS

CODE	material	weight [g]	anchor system diameter*	pcs
CORNER	stainless steel / AISI 316	 44	M12	1

* The values indicated are the result of experimental tests carried out under the supervision of third parties in accordance with the standards referred to. For a correct calculation report with minimum distances according to the standard requirements, the substructure must be checked by a qualified engineer before installation.

C-LEVER



DIVERSION SYSTEM FOR ROPE ACCESS AND FAÇADE WORK



ADAPTABLE

The adjustable structure allows the configuration to be adapted, and railings or obstacles of varying sizes to be easily overcome.

RAPID DEPLOYMENT

The quick coupling/uncoupling system enables the structure to be easily and efficiently assembled and disassembled.

USER FRIENDLY

The smart integration of the ropes within the system simplifies use and recovery operations.

MAXIMUM NUMBER OF USERS



LOAD DIRECTION



TYPES OF APPLICATION

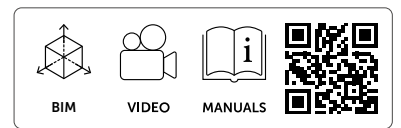

■ FIELDS OF APPLICATION

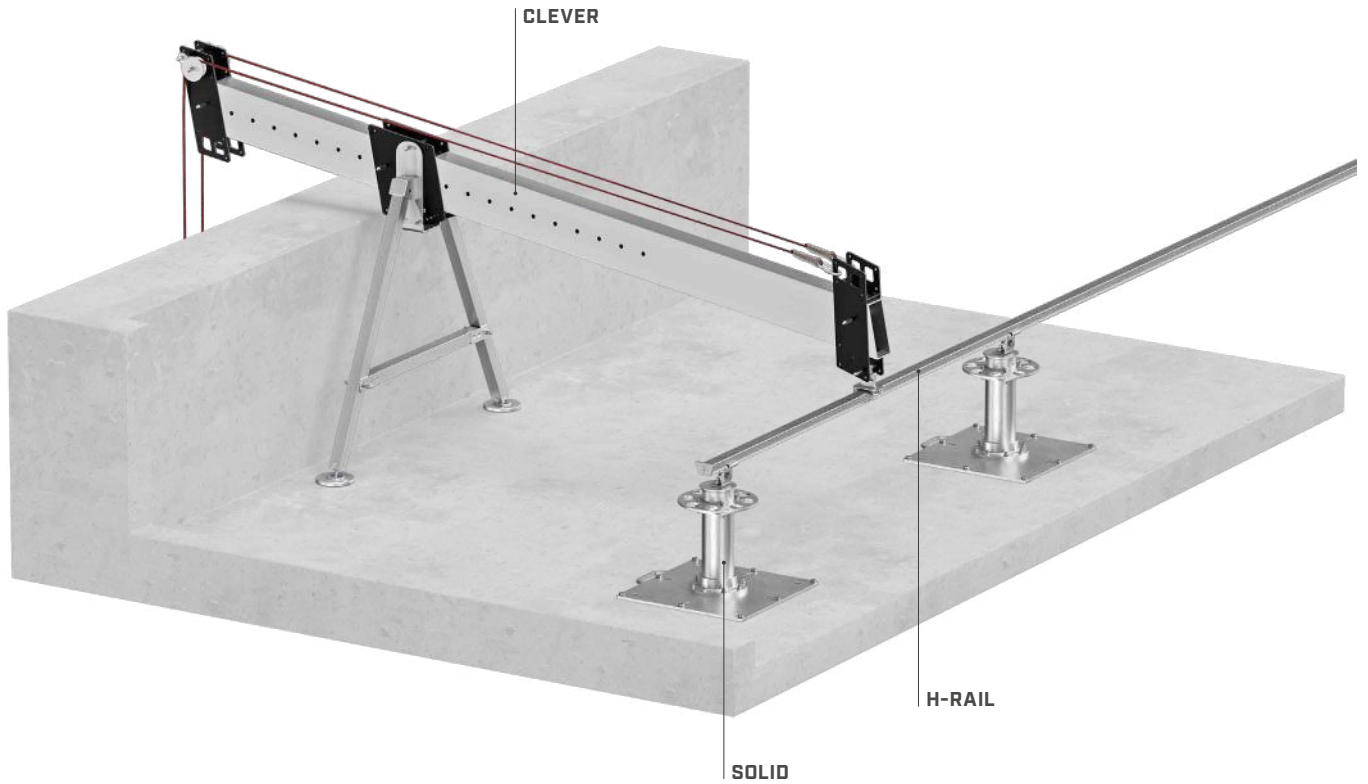

■ C-LEVER | CODES AND DIMENSIONS

	system characteristics	
code	CLEVER	
description	diversion system for rope access and façade work	
materials	EN AW-6082-T6/AISI 304 / EN AW-5083 / LDPE	<div style="display: flex; gap: 5px;"> <div style="border: 1px solid black; padding: 2px; font-size: 8px;">alu 6082</div> <div style="border: 1px solid black; padding: 2px; font-size: 8px;">A2 AISI 304</div> <div style="border: 1px solid black; padding: 2px; font-size: 8px;">alu 5083</div> </div>
main beam length	3000 mm (118 1/8 inch)	
anchor points	2 rear points for diversion through pulleys and anchoring to the fall protection system 2 front points for direct attachment	
WLL (working load limit)	500 kg (227 lb)	

		recommended dimensions for use
anchor-to-façade distance	L [mm] [in]	1700 - 2700 66 15/16 - 106 5/16
railing height	H _p [mm] [in]	up to 1000 up to 39 3/8
railing thickness	D _p [mm] [in]	up to 800 up to 31 1/2
anchor height	H _a [mm] [in]	300 - 500 11 3/4 - 19 3/4

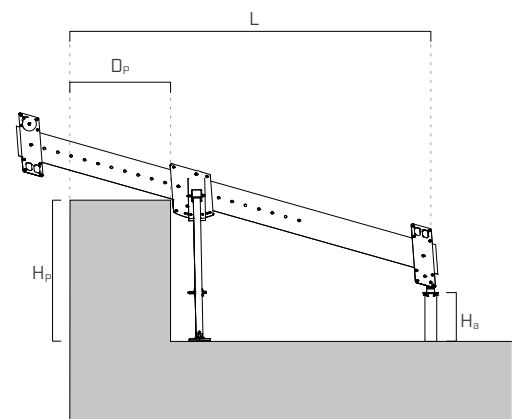

SOLID

RIGID ANCHOR POINT FOR ROPE ACCESS WORK

DESIGNED FOR ROPE ACCESS WORK

The high-rigidity and high-strength support, combined with the jaw-plate anchor system, enables rope access work to be carried out comfortably and safely.

LIGHT

The aluminium alloy comprising the support facilitates handling and installation thanks to the lightweight components.

ADAPTABLE

Support height between 400 and 1000 mm adapts to different roofing thicknesses.

EN 795:2012 A	CEN/TS 18415:2013	UNI 11578:2015 A	ANSI* Z359.1B -2017 A	BS 8610:2017 A3/A5	AS/NZS 5532:2013
---------------	-------------------	------------------	-----------------------	--------------------	------------------

*The system has been developed and tested in accordance with the static, dynamic and residual strength requirements outlined in the relative ANSI standard.



MAXIMUM NUMBER OF USERS



LOAD DIRECTION



TYPES OF APPLICATION



■ FIELDS OF APPLICATION

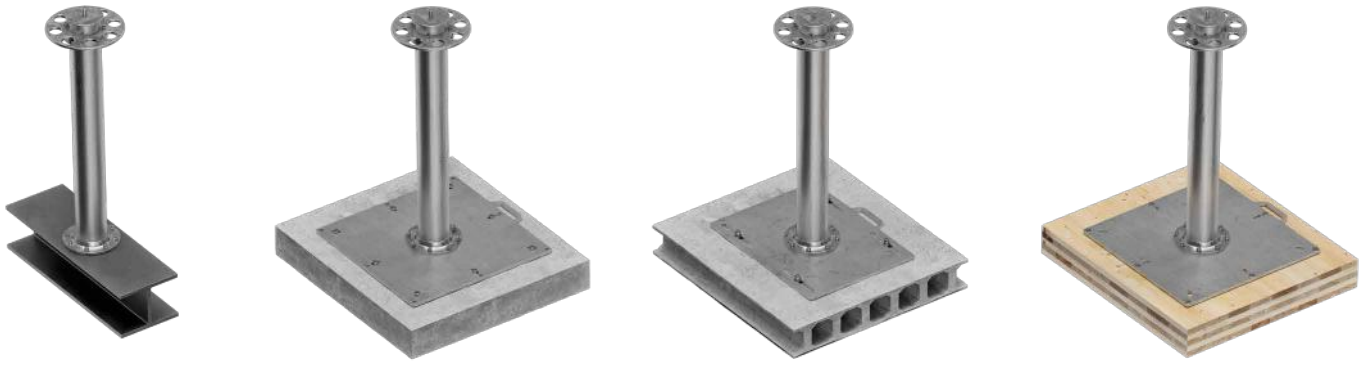

■ TECHNICAL DATA**

substructure	minimum thickness	fasteners	substructure	minimum thickness	fasteners
CLT	160 mm	VGS (EVO) Ø13 HUS12	C20/25	140 mm	AB1 Ø12
C20/25	-	INA Ø16 8.8			SKR (EVO) Ø12
S235	15 mm	bolt or rod M12 10.9			INA Ø12 8.8 VIN-FIX

		SOLIDRIG					
		EN 795:2012 A	CEN/TS 16415:2013	UNI 11578:2015 A	BS 8810:2017 A3/A5	AS/NZS 5532:2013	ANSI* Z358.18 - 2017 A
maximum number of users	no.						

**The values indicated are the result of experimental tests carried out under the supervision of third parties in accordance with the standard referred to. For a correct calculation report with minimum distances according to the standard requirements, the substructure must be checked by a qualified engineer before installation.

■ SOLID | CODES AND DIMENSIONS

CODE	description	material	d ₁	B	L	H	pcs	
			[mm] [in]	[mm] [in]	[mm] [in]	[mm] [in]		
SOLID400	rigid support for rope access work		120	220,5	-	400	1	
SOLID600			4.73	8 11/16	-	23 5/8	1	
SOLID800			4.73	8 11/16	-	31 1/2	1	
SOLID1000			4.73	8 11/16	-	39 3/8	1	
SOLIDRIG	jaw system for rope access work	EN AW-6082-T6	300	-	-	-	1	
SOLIDPLATE	bottom plate for timber and concrete		-	550	595	-	1	
			-	21 5/8	23 7/16	-		
SOLIDPLATEHD	bottom plate for timber and concrete for heavy-duty applications		-	650	695	-	1	
			-	25 9/16	27 3/8	-		
SOLIDPLATEHC	bottom plate and counterplate for aerated concrete		-	650	545	-	1	
			-	25 9/16	21 7/16	-		

LOOP

ANCHOR POINT FOR TIMBER AND CONCRETE SUBSTRUCTURE

LOW PROFILE

Under-tile fastening ensures a low visual impact, ideal for installation on roofs in historic centres.

FAST

Fast and easy installation, with just two HBS Ø8 screws.

ADAPTABLE

Thanks to its KRAKEN support, it can also be installed on thin concrete roofs.



EN 795:2012 A
UNI 11578:2015 A



MAXIMUM NUMBER OF USERS



LOAD DIRECTION



TYPES OF APPLICATION



TECHNICAL DATA*

substructure	minimum thickness	fasteners
GL24h	100 x 100 mm	HBS Ø8

* The values indicated are the result of experimental tests carried out under the supervision of third parties in accordance with the standards referred to. For a correct calculation report with minimum distances according to the standard requirements, the substructure must be checked by a qualified engineer before installation.

substructure	minimum thickness	fastening + KRAKEN
C20/25	100 mm	M8 5.8 rod + ULS + MUT VIN-FIX HYB-FIX

CODES AND DIMENSIONS

CODE	material	B [mm] [in]	H [mm] [in]	L [mm] [in]	pcs	
LOOP	AISI 316 stainless steel grade 1.4401 / EN AW 6060 T6	-	12 1/2	456 17 15/16	1	
LOOPXL	AISI 316 stainless steel grade 1.4401 / EN AW 6060 T6	-	12 1/2	756 29 3/4	1	
KRAKEN	AISI 430 stainless steel grade 1.4016 IIA	100 4	18 11/16	116 4 9/16	1	

CODE	description	page
MULTIPLATE	universal counterplate	253
OMEGA	accessory for MULTIPLATE	253

CODE	description	page
MULTIBEF	fastening set for MULTIPLATE	254

HOOK SPIKE



ANCHOR POINT WITH LADDER HOOK

PRACTICAL

Designed to attach a portable ladder to facilitate the operator's ascent on steep roofs.

SAFE

Tested according to the standard directly on the substructure, it guarantees safety and freedom of movement in all directions.

VERSATILE

Thanks to the three different heights of the plate, it is possible to choose and assemble the hook according to the type of tile installed on the roof.

EN 517-B:
2006



MAXIMUM NUMBER
OF USERS



LOAD DIRECTION



TYPES OF
APPLICATION

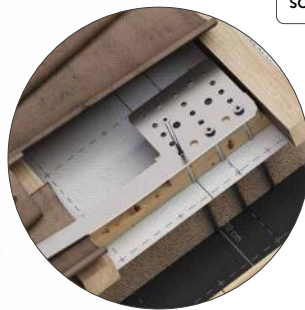
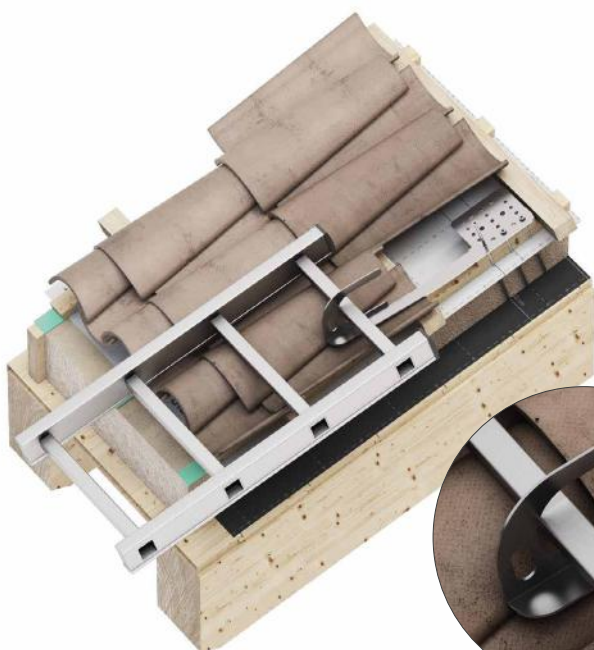
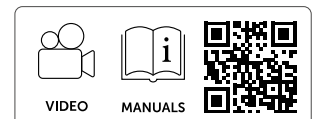

stainless steel

brown

anthracite



TECHNICAL DATA*

substructure	minimum thickness	fasteners
GL24h	100 x 100 mm	HBS Ø8

* The values indicated are the result of experimental tests carried out under the supervision of third parties in accordance with the standards referred to. For a correct calculation report with minimum distances according to the standard requirements, the substructure must be checked by a qualified engineer before installation.

CODES AND DIMENSIONS

CODE	material	colour	B		H		H ₁		L		pcs
			[mm]	[in]	[mm]	[in]	[mm]	[in]	[mm]	[in]	
HOOKS	AISI 304 stainless steel grade 1.4301	(stainless steel)	132	5 3/16	-	-	112	4 7/16	520	20 1/2	1
HOOKS20			132	5 3/16	20	13/16	144	5 11/16	520	20 1/2	1
HOOKS50			132	5 3/16	50	1 15/16	174	6 7/8	520	20 1/2	1
HOOKSB		(brown)	132	5 3/16	-	-	112	4 7/16	520	20 1/2	1
HOOKSB20			132	5 3/16	20	13/16	144	5 11/16	520	20 1/2	1
HOOKSB50			132	5 3/16	50	1 15/16	174	6 7/8	520	20 1/2	1
HOOKSA		(anthracite)	132	5 3/16	-	-	112	4 7/16	520	20 1/2	1
HOOKSA20			132	5 3/16	20	13/16	144	5 11/16	520	20 1/2	1
HOOKSA50			132	5 3/16	50	1 15/16	174	6 7/8	520	20 1/2	1

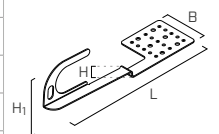

HOOK EVO

ANCHOR POINT FOR TIMBER SUBSTRUCTURE

LOW PROFILE

Under-tile fastening ensures a low visual impact on the roof, for a visually appealing result.

ADAPTABLE

Quick and easy installation using Ø8 HBS screws. The base plate with an increased number of holes allows the anchor to be mounted in different positions, depending on the type of roof tiles.

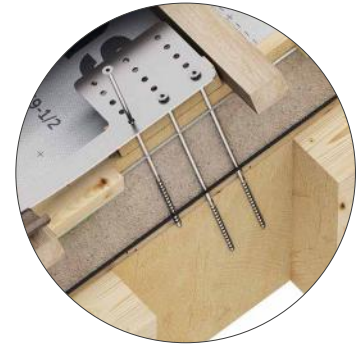

EN 795:2012 A	UNI 11578:2015 A
---------------------	------------------------



MAXIMUM NUMBER OF USERS



LOAD DIRECTION



TYPES OF APPLICATION

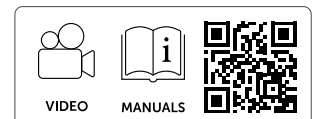

TECHNICAL DATA*

substructure	minimum thickness	fasteners
GL24h	100 x 100 mm	HBS Ø8

* The values indicated are the result of experimental tests carried out under the supervision of third parties in accordance with the standards referred to. For a correct calculation report with minimum distances according to the standard requirements, the substructure must be checked by a qualified engineer before installation.

CODES AND DIMENSIONS

CODE	material		B [mm] [in]	H [mm] [in]	L [mm] [in]	pcs
HOOKEVO	AISI 430 stainless steel grade 1.4016		132 5 3/16	79 3 1/8	490 19 5/16	1

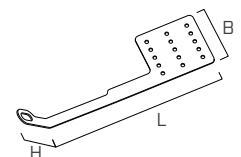

HOOK EVO 2.0

ANCHOR POINT FOR TIMBER AND CONCRETE SUBSTRUCTURE

PRACTICAL

The bottom plate allows the anchor to be assembled in different positions on both timber and concrete, depending on the height of the battens and the type of tiles.

LOW PROFILE

Under-tile fastening ensures a low visual impact on the roof, for a visually appealing result.

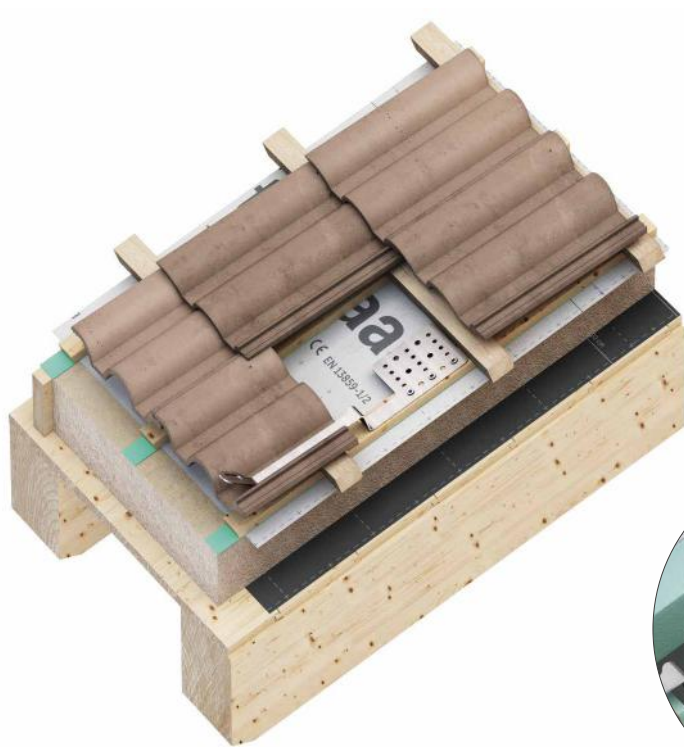

EN 795:2012 A
UNI 11578:2015 A



MAXIMUM NUMBER OF USERS



LOAD DIRECTION



TYPES OF APPLICATION

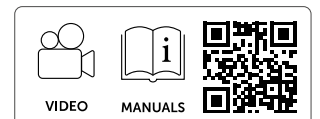

TECHNICAL DATA*

substructure	minimum thickness	fasteners	substructure	minimum thickness	fasteners
C24	80 x 100 mm + 18 mm of wooden plank	HBS Ø8	C20/25	100 mm	AB1 Ø10 M10 rod + ULS + MUT VIN-FIX/HYB-FIX

* The values indicated are the result of experimental tests carried out under the supervision of third parties in accordance with the standards referred to. For a correct calculation report with minimum distances according to the standard requirements, the substructure must be checked by a qualified engineer before installation.

CODES AND DIMENSIONS

CODE	material	B	H	H ₁	L	pcs
		[mm] [in]	[mm] [in]	[mm] [in]	[mm] [in]	
HOOKEVO20		132 5 3/16	20 13/16	92 3 5/8	520 20 1/2	5
HOOKEVO50	AISI 304 stainless steel grade 1.4301	132 5 3/16	50 1 15/16	122 4 13/16	520 20 1/2	5
HOOKEVO100		132 5 3/16	100 4	172 6 3/4	520 20 1/2	5

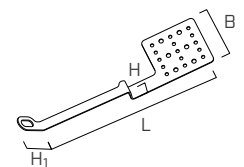

SLIM



ANCHOR POINT FOR SMALL STRUCTURES

ADAPTABLE

Can be installed on small beams, with minimum dimensions of 38 x 68 mm with no limits on maximum width.

MULTIPURPOSE

Can be used as single points or as a hook for ladders.

EN 795:2012 A	EN 517-B:2008	UNI 11578:2015 A
---------------------	------------------	------------------------



MAXIMUM NUMBER OF USERS



LOAD DIRECTION



TYPES OF APPLICATION

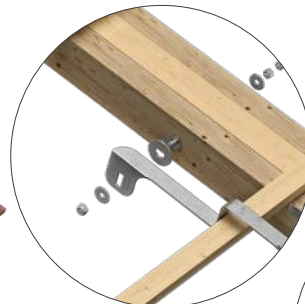
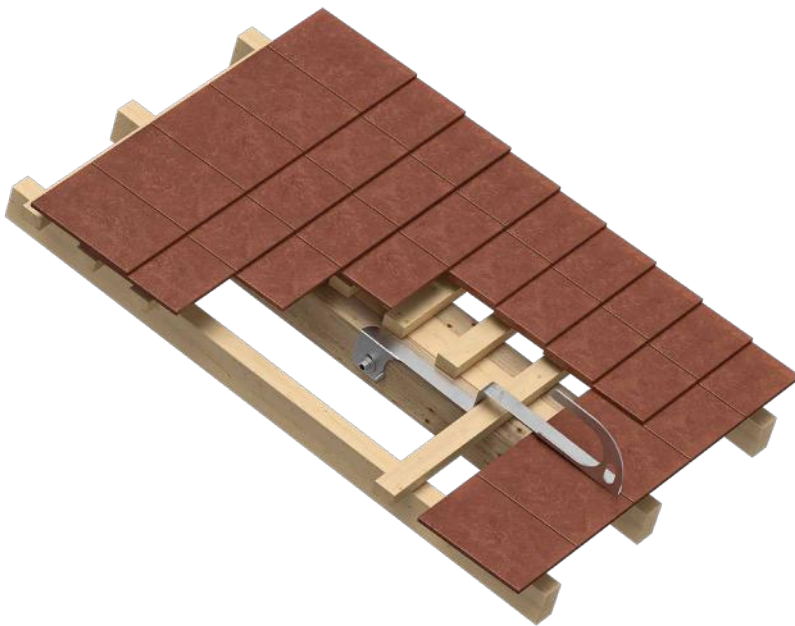

BEFSLIM2

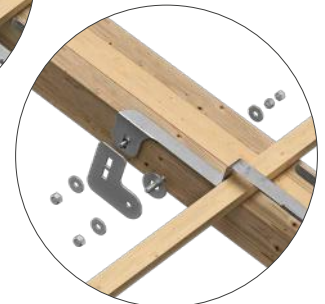

BEFSLIM1



TECHNICAL DATA*

substructure	minimum thickness	fastening set
GL24h	114 x 68 mm	BEFSLIM1, BEFSLIM2

* The values indicated are the result of experimental tests carried out under the supervision of third parties in accordance with the standards referred to. For a correct calculation report with minimum distances according to the standard requirements, the substructure must be checked by a qualified engineer before installation.

CODES AND DIMENSIONS

CODE	material		B [mm] [in]	H [mm] [in]	H ₁ [mm] [in]	L [mm] [in]	pcs	
SLIM	AISI 430 stainless steel grade 1.4016		30 1 3/16	173 6 13/16	60 2 3/8	500 19 3/4	5	

CODE	description	page
BEFSLIM1	fastening set for SLIM	254

CODE	description	page
BEFSLIM2	height-adjustable fastening set for SLIM	254

KITE

ANCHOR POINT

VERSATILE

Ideal as an anchor point in multiple environments, it allows the operator to safely access.

SAFE

Laser cut from a single piece with no welding points, it improves safety in all its applications.

PRACTICAL

Thanks to its lightweight and compact size, this anchor can be installed quickly and easily.

EN 795:2012 A	UNI 11578:2015 A	OSHA 1926.502 (d)(15)	DrJ LST-2407- 116
---------------------	------------------------	-----------------------------	-------------------------



MAXIMUM NUMBER OF USERS



LOAD DIRECTION



TYPES OF APPLICATION

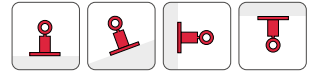

TECHNICAL DATA*

substructure	minimum thickness	fasteners	substructure	minimum thickness	fasteners
GL24h	100 x 100 mm	2 x HBS Ø8 1 x VGS Ø11	C20/25	140 mm	AB1 Ø12 M12 8.8 rod + ULS + MUT VIN-FIX HYB-FIX
S235JR	5 mm	EKS M12 8.8 + ULS + nut			

* The values indicated are the result of experimental tests carried out under the supervision of third parties in accordance with the standards referred to. For a correct calculation report with minimum distances according to the standard requirements, the substructure must be checked by a qualified engineer before installation.

CODES AND DIMENSIONS

CODE	material	B [mm] [in]	L [mm] [in]	pcs	
KITE	AISI 430 stainless steel grade 1.4016	101 [4]	100 [4]	1	

ACCESSORIES

CODE	description	
BEFKITE	KITE fastening set for timber	

SIANK

ANCHOR POINT FOR STANDING SEAM METAL ROOFS

EFFICIENT

The system is fixed to a single seam of the sheet using a few tools.

PRACTICAL

Device fixed to the seam by means of a single clamp, without the need to drill holes in the metal sheet, guaranteeing its impermeability and durability.



EN 795:2012 A	CEN/TS 18418:2013	UNI 11578:2015 A
---------------------	----------------------	------------------------



MAXIMUM NUMBER OF USERS



LOAD DIRECTION



TYPES OF APPLICATION

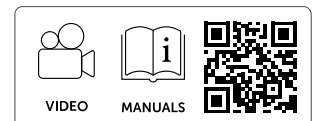

TECHNICAL DATA*

substructure	minimum thickness
Fe	0,5 mm
Al	0,7 mm
Cu	0,5 mm

substructure	minimum thickness
Zn - Ti	0,7 mm
STAINLESS STEEL	0.4 mm

* The values indicated are the result of experimental tests carried out under the supervision of third parties in accordance with the standards referred to. For a correct calculation report with minimum distances according to the standard requirements, the substructure must be checked by a qualified engineer before installation.

CODES AND DIMENSIONS

CODE	material	colour	seam height [mm] [in]	B [mm] [in]	H [mm] [in]	L [mm] [in]	pcs
SIANK			25 1	163 6 7/16	130 5 1/8	400 15 3/4	1
SIANK65	AISI 304 stainless steel	(stainless steel)	65 2 9/16	104 4 1/8	163 6 7/16	400 15 3/4	1
SIANKA	grade 1.4301	 (anthracite)	25 1	163 6 7/16	130 5 1/8	400 15 3/4	1
SIANKB		 (brown)	25 1	163 6 7/16	130 5 1/8	400 15 3/4	1

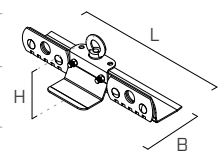

AOS

ANCHOR POINT

UNIVERSAL

The threaded rod available in various lengths allows the anchor to adapt to any type of timber, concrete and steel structure.

FUNCTIONAL

The 360° swivel eyelet allows the operator total freedom of movement on the roof.

COMPLETE

Supplied in a handy kit complete with bolts and washers for installation.

EN 795:2012 A	CEN/TS 18418:2013	UNI 11578:2015 A
---------------------	----------------------	------------------------



MAXIMUM NUMBER OF USERS



LOAD DIRECTION



TYPES OF APPLICATION



TECHNICAL DATA*

substructure	minimum thickness	substructure	minimum thickness	fasteners
GL24h	100 x 120 mm	C20/25	164 mm	VIN-FIX HYB-FIX
S235JR	5 mm			

* The values indicated are the result of experimental tests carried out under the supervision of third parties in accordance with the standards referred to. For a correct calculation report with minimum distances according to the standard requirements, the substructure must be checked by a qualified engineer before installation.

CODES AND DIMENSIONS

CODE	material	max. thickness of fixture		H		pcs	
		[mm]	[in]	[mm]	[in]		
AOS50	AISI 304 stainless steel grade 1.4301	29	1 1/8	80	3 1/8	1	
AOS50A4	AISI 316 stainless steel grade 1.4401	29	1 1/8	80	3 1/8	1	
AOS130	AISI 304 stainless steel grade 1.4301	132	5 3/16	175	6 7/8	1	
AOS130A4	AISI 316 stainless steel grade 1.4401	132	5 3/16	175	6 7/8	1	
AOS200	AISI 304 stainless steel grade 1.4301	164	6 7/16	250	10	1	
AOS300		264	10 3/8	350	13 3/4	1	
AOS400		364	14 5/16	450	17 3/4	1	
AOS500		464	18 1/4	550	21 5/8	1	
AOS200A4	AISI 316 stainless steel grade 1.4401	164	6 7/16	250	10	1	
AOS300A4		264	10 3/8	350	13 3/4	1	
AOS400A4		364	14 5/16	450	17 3/4	1	
AOS500A4		464	18 1/4	550	21 5/8	1	

ACCESSORIES

CODE	description	page	CODE	description	page
OMEGA	accessory for MULTIPLATE	253	MULTIPLATE	fixed counterplate	253

AOS01 + TOWER/TOWER A2

ANCHOR POINT FOR TIMBER, CONCRETE AND STEEL SUBSTRUCTURES

PRACTICAL

Support height between 300 and 800 mm to adapt to different roofing thicknesses.

EFFECTIVE

Device with controlled deformation to limit load transfer to the structure.

LOW PROFILE

Small-sized cylindrical system, minimises the visual impact on the roof.



EN 795:2012 A	CEN/TS 16415:2013	UNI 11578:2015 A	AS/NZS 5532:2013	AS/NZS 1891.4:2009
---------------	-------------------	------------------	------------------	--------------------



MAXIMUM NUMBER OF USERS



LOAD DIRECTION



TYPES OF APPLICATION

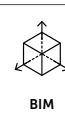

TECHNICAL DATA*

substructure	minimum thickness	fasteners	substructure	minimum thickness	fasteners
GL24h	160 x 160 mm	VGS Ø9	C20/25	140 mm	AB1 Ø12
CLT	200 mm	VGS Ø9			rod M12
S235JR	6 mm	EKS+ULS+MUT			VIN-FIX HYB-FIX

* The values indicated are the result of experimental tests carried out under the supervision of third parties in accordance with the standards referred to. For a correct calculation report with minimum distances according to the standard requirements, the substructure must be checked by a qualified engineer before installation.

TOWER/TOWER A2 | CODES AND DIMENSIONS

CODE	material		d ₁		B		H		L		pcs		
			[mm]	[in]	[mm]	[in]	[mm]	[in]	[mm]	[in]			
TOWER300	S235JR zinc plated steel		48	1.89	150	6	300	11 3/4	150	6	1		
TOWER400			48	1.89	150	6	400	15 3/4	150	6	1		
TOWER500			48	1.89	150	6	500	19 3/4	150	6	1		
TOWER600			48	1.89	150	6	600	23 5/8	150	6	1		
TOWER700			48	1.89	150	6	700	27 1/2	150	6	1		
TOWER800			48	1.89	150	6	800	31 1/2	150	6	1		
TOWER22500			48	1.89	150	6	500	19 3/4	150	6	1		
TOWERA2300			AISI 304 stainless steel grade 1.4301		48	1.89	150	6	300	11 3/4	150	6	1
TOWERA2400					48	1.89	150	6	400	15 3/4	150	6	1
TOWERA2500					48	1.89	150	6	500	19 3/4	150	6	1
AOS01	AISI 304 stainless steel grade 1.4301		-	-	60	2 3/8	-	-	98	3 7/8	1		

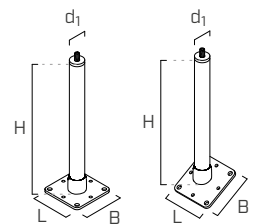

AOS01 + TOWER XL

ANCHOR POINT WITH INCREASED BOTTOM PLATE FOR TIMBER, STEEL AND CONCRETE SUBSTRUCTURES

SAFE

The enlarged bottom plate allows for the distribution of actions resulting from the anchoring devices over a wider area.

PRACTICAL

Support height between 300 and 800 mm to adapt to different roofing thicknesses.

EFFECTIVE

Device with controlled deformation, it dissipates a part of the energy built up during a fall to limit the load transferred to the fastening and the structure.

EN 795:2012 A	CEN/TS 16415:2013 A	UNI 11578:2015 A
---------------------	---------------------------	------------------------

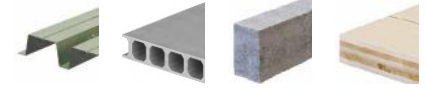

MAXIMUM NUMBER OF USERS



LOAD DIRECTION



TYPES OF APPLICATION

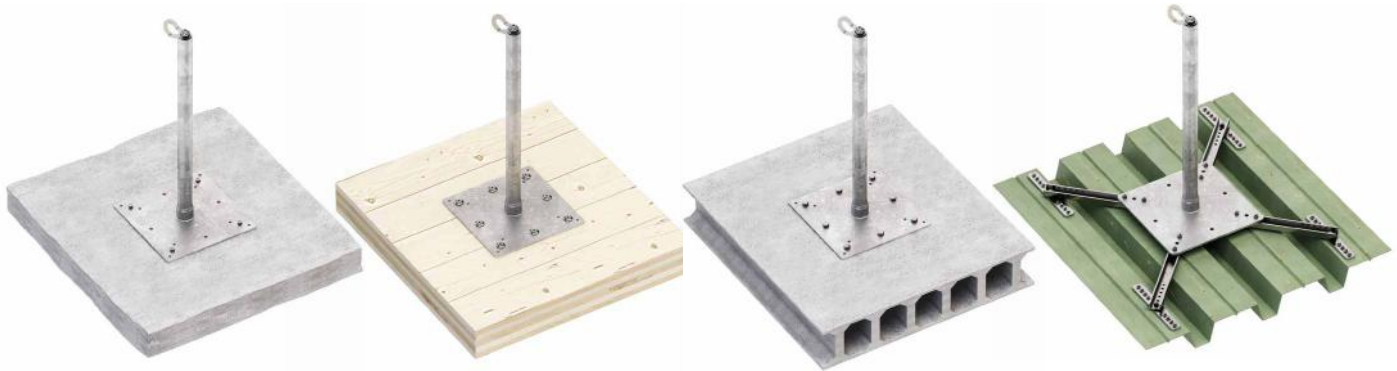
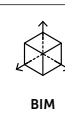
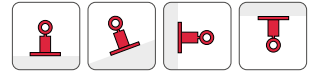

TECHNICAL DATA*

substructure	minimum thickness	fasteners	substructure	minimum thickness	fasteners
CLT	100 mm	VGS Ø11	C20/25	110 mm	ABE Ø10
C45/55	30 mm	BEFTOWERXL1			rod M10
TRAPO	0,75 mm	TRAPO set			VIN-FIX
					SKR CE Ø10

* The values indicated are the result of experimental tests carried out under the supervision of third parties in accordance with the standards referred to. For a correct calculation report with minimum distances according to the standard requirements, the substructure must be checked by a qualified engineer before installation.

TOWER XL | CODES AND DIMENSIONS

CODE	material	d ₁ [mm] [in]	B [mm] [in]	H [mm] [in]	L [mm] [in]	pcs	
TOWERXL300	S235JR zinc plated steel	48 1.89	350 13 3/4	300 11 3/4	350 13 3/4	1	
TOWERXL400		48 1.89	350 13 3/4	400 15 3/4	350 13 3/4	1	
TOWERXL500		48 1.89	350 13 3/4	500 19 3/4	350 13 3/4	1	
TOWERXL600		48 1.89	350 13 3/4	600 23 5/8	350 13 3/4	1	
TOWERXL700		48 1.89	350 13 3/4	700 27 1/2	350 13 3/4	1	
TOWERXL800		48 1.89	350 13 3/4	800 31 1/2	350 13 3/4	1	
TOWERXL1000		48 1.89	350 13 3/4	1000 39 3/8	350 13 3/4	1	
AOS01		AISI 304 stainless steel grade 1.4301	-	60 2 3/8	-	98 3 7/8	1

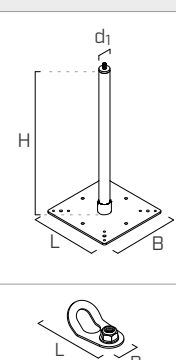

AOS01 + T-CLAMP

ANCHOR POINT ON SUPPORT FOR CONTINUOUS ROOFS

VERSATILE

A versatile system with special clamps allowing installation on various types of metal roofs.

ADAPTABLE

The various sizes of the universal plates guarantee a solution for the different spans of the seams.

MODULAR

The optional post allows the anchor point to be raised, thus overcoming obstacles on the roof.

EN 795:2012 A	CEN/TS 18415:2013	UNI 11578:2015 A	AS/NZS 5532:2013
---------------------	----------------------	------------------------	---------------------

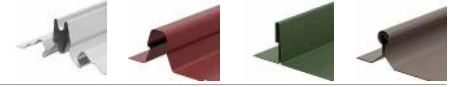

MAXIMUM NUMBER OF USERS



LOAD DIRECTION



TYPES OF APPLICATION

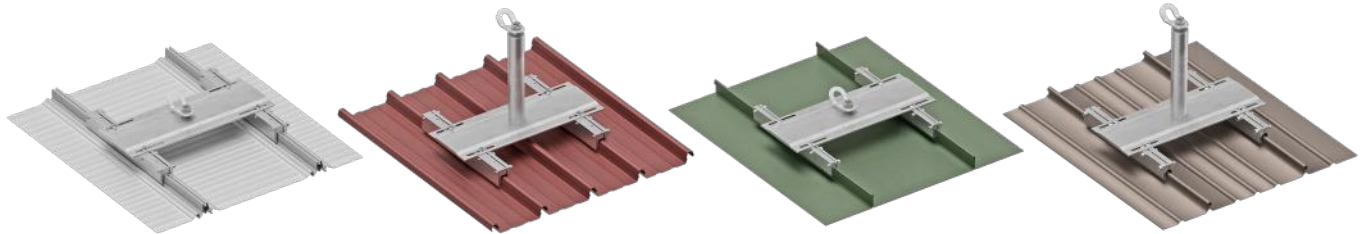

T-CLAMP | CODES AND DIMENSIONS

CODE	description	material	B [mm] [in]	H [mm] [in]	L [mm] [in]	pcs	
TCLAMP500	universal plate for small and medium spans between seams	EN AW-6082-T6	190 7 1/2	- -	515 20 1/4	1	
TCLAMP700	universal plate for large spans between seams		190 7 1/2	- -	760 29 15/16	1	
TCLAMPTUBE300	optional spacer to overcome obstacles	EN AW-6060-T6/ AISI 304	50 1 15/16	300 11 3/4	- -	1	
TCLAMPKLIP	fastening clamps set for Klip-Lok type roofs		- -	- -	- -	1	
TCLAMPRIVER	fastening clamps set for Riverclack type roofs	EN AW-6060-T6	- -	- -	- -	1	
TCLAMPROUND	fastening clamps set for round standing seam roofs		- -	- -	- -	1	-
TCLAMPSTAND	fastening clamps set for seam type roofs		- -	- -	- -	1	
AOS01	anchor point	AISI 304 stainless steel grade 1.4301	60 2 3/8	- -	98 3 7/8	1	

AOS01 + SHIELD

ANCHOR POINT FOR TRAPEZOIDAL METAL ROOFS

LOW PROFILE

It ensures a reduced visual impact thanks to its small size.

PACKAGING

Supplied complete with mounting rivets and cellular rubber gaskets for perfect waterproofing.

EN 795:2012 A	CEN/TS 18415:2013	UNI 11578:2015 A	AS/NZS 5532:2013	AS/NZS 1891.4:2009
---------------	-------------------	------------------	------------------	--------------------



MAXIMUM NUMBER OF USERS



LOAD DIRECTION



TYPES OF APPLICATION

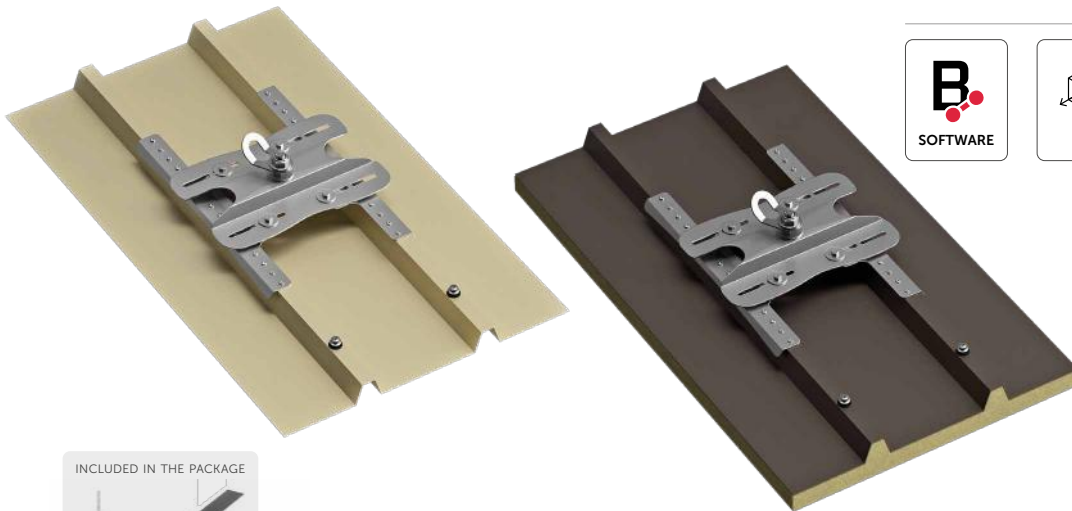
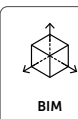

INCLUDED IN THE PACKAGE



TECHNICAL DATA*

substructure	minimum thickness EN 795 TYPE A	fastening systems included	substructure	minimum thickness AS/NZS 5532:2013	fastening systems included ⁽¹⁾
Fe	0,4 mm	rivet 6,3 x 20,2 mm with EPDM washer (x 32)	Fe	0,42 mm	rivet 6,3 x 20,2 mm with EPDM washer (x 30)
Al	0,6 mm				

⁽¹⁾ FASTENING SYSTEMS NOT INCLUDED: 2 x Metal Tek 14 g x 75 mm for steel beams or 2 x TBSEVO08120 for timber beams

* The values indicated are the result of experimental tests carried out under the supervision of third parties in accordance with the standards referred to. For a correct calculation report with minimum distances according to the standard requirements, the substructure must be checked by a qualified engineer before installation.

SHIELD | CODES AND DIMENSIONS

CODE	material		B [mm] [in]	H [mm] [in]	L [mm] [in]	pcs	
SHIELD	AISI 304 stainless steel grade 1.4301	A2 AISI 304	180-420 7 1/8-16 9/16	85 3 3/8	476 18 3/4	1	
SHIELDA4	AISI 316 stainless steel grade 1.4401	A4 AISI 316	180-420 7 1/8-16 9/16	85 3 3/8	476 18 3/4	1	
AOS01	AISI 304 stainless steel grade 1.4301	A2 AISI 304	60 2 3/8	-	98 3 7/8	1	
AOS01A4	AISI 316 stainless steel grade 1.4401	A4 AISI 316	60 2 3/8	-	98 3 7/8	1	

AOS01 + SHIELD 2

ANCHOR POINT FOR TRAPEZOIDAL METAL ROOFS

FAST

Easy installation because it is configured as a single plate.

COMPLETE

The package includes fasteners and cellular rubber gaskets, to ensure waterproofing.

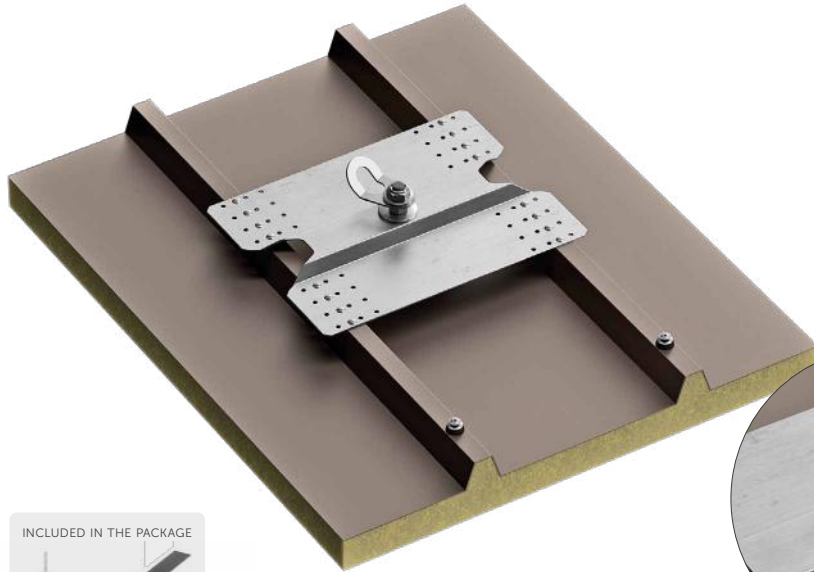

EN 795:2012 A	CEN/TS 18415:2013	UNI 11578:2015 A	AS/NZS 5532:2013	AS/NZS 1891.4:2009
---------------	-------------------	------------------	------------------	--------------------



MAXIMUM NUMBER OF USERS



LOAD DIRECTION



TYPES OF APPLICATION

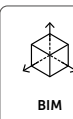

TECHNICAL DATA*

substructure	minimum thickness EN 795 TYPE A	fastening systems included
Fe	0,5 mm	rivet 6,3 x 20,2 mm with EPDM washer (x 16)
Al	0,7 mm	
Al	1,0 mm	

substructure	minimum thickness AS/NZS 5532:2013	fastening systems included ⁽¹⁾
Fe	0,42 mm	rivet 6,3 x 20,2 mm with EPDM washer (x 14)

⁽¹⁾ FASTENING SYSTEMS NOT INCLUDED: 2 x Metal Tek 14 g x 75 mm for steel beams or 2 x TBSEVO08120 for timber beams

* The values indicated are the result of experimental tests carried out under the supervision of third parties in accordance with the standards referred to. For a correct calculation report with minimum distances according to the standard requirements, the substructure must be checked by a qualified engineer before installation.

SHIELD 2 | CODES AND DIMENSIONS

CODE	material		B [mm] [in]	H [mm] [in]	L [mm] [in]	pcs	
SHIELD2	AISI 304 stainless steel grade 1.4301	A2 AISI 304	420 16 9/16	65 2 9/16	322 12 11/16	1	
SHIELD2A4	AISI 316 stainless steel grade 1.4401	A4 AISI 316	420 16 9/16	65 2 9/16	322 12 11/16	1	
AOS01	AISI 304 stainless steel grade 1.4301	A2 AISI 304	60 2 3/8	-	98 3 7/8	1	
AOS01A4	AISI 316 stainless steel grade 1.4401	A4 AISI 316	60 2 3/8	-	98 3 7/8	1	

AOS01 + WAVE

ANCHOR POINT FOR CORRUGATED SHEET METAL ROOFS

SIMPLE

Simple and quick installation, thanks to the shape obtained with a single plate.

COMPLETE

The package includes fasteners and cellular rubber gaskets, to ensure waterproofing.

EN 795:2012 A	CEN/TS 18418:2013	UNI 11578:2015 A
---------------------	----------------------	------------------------

MAXIMUM NUMBER OF USERS



LOAD DIRECTION



TYPES OF APPLICATION

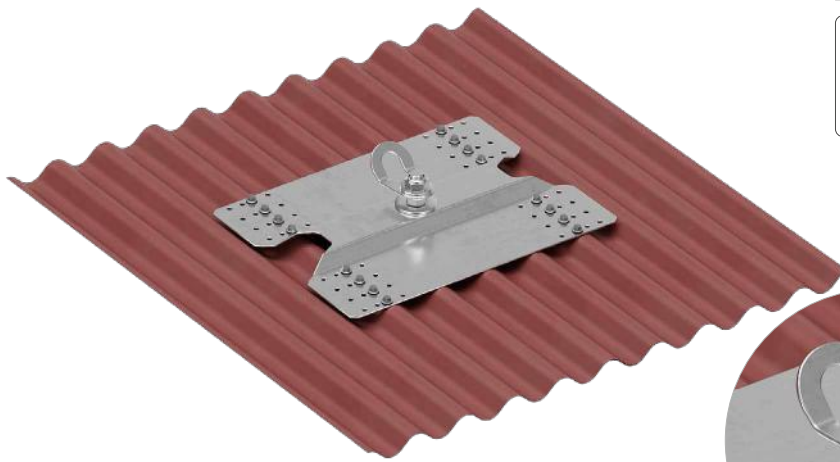
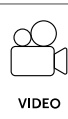
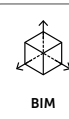

TECHNICAL DATA*

substructure	minimum thickness	fastening systems included ⁽¹⁾
Fe	0,63 mm	self-drilling screws 5,5 x 25 mm A2 with EPDM washer (x16) and 4 EPDM gaskets

* The values indicated are the result of experimental tests carried out under the supervision of third parties in accordance with the standards referred to. For a correct calculation report with minimum distances according to the standard requirements, the substructure must be checked by a qualified engineer before installation.

WAVE | CODES AND DIMENSIONS

CODE	material		B [mm] [in]	H [mm] [in]	L [mm] [in]	pcs	
WAVE	AISI 304 stainless steel grade 1.4301		420 16 9/16	65 2 9/16	322 12 11/16	1	
AOS01	AISI 304 stainless steel grade 1.4301		60 2 3/8	- -	98 3 7/8	1	

AOS01 + COPPO

ANCHOR POINT FOR ROOFS WITH FAUX TILES

FAST

Easy installation because it is configured as a single plate.

COMPLETE

The package includes fasteners and cellular rubber gaskets, to ensure waterproofing.

EN 795:2012 A	CEN/TS 18418:2013	UNI 11578:2015 A
---------------------	----------------------	------------------------



MAXIMUM NUMBER OF USERS



LOAD DIRECTION



TYPES OF APPLICATION

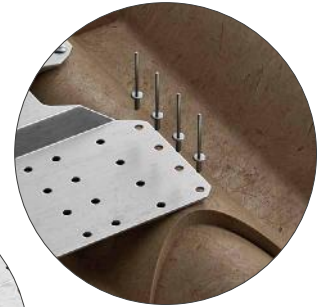
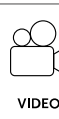
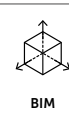

TECHNICAL DATA*

substructure	minimum thickness	fastening systems included	substructure	minimum thickness	fastening systems included
Fe	0,5 mm	rivet 6,3 x 20,2 mm with EPDM washer (x 24)	Al	0,7 mm	rivet 6,3 x 20,2 mm with EPDM washer (x 24)

* The values indicated are the result of experimental tests carried out under the supervision of third parties in accordance with the standards referred to. For a correct calculation report with minimum distances according to the standard requirements, the substructure must be checked by a qualified engineer before installation.

COPPO | CODES AND DIMENSIONS

CODE	material		B [mm] [in]	H [mm] [in]	L [mm] [in]	pcs	
COPPO	AISI 304 stainless steel grade 1.4301		420 16 9/16	65 2 9/16	322 12 11/16	1	
AOS01	AISI 304 stainless steel grade 1.4301		60 2 3/8	-	98 3 7/8	1	

AOS01 + BLOCK



BALLASTED ANCHOR POINT FOR FLAT ROOFS

WITHOUT PERFORATIONS

No drilling of the roof covering required, and avoids thermal bridging.

FLAT ROOFS

Designed for flat roofs with inclines up to 5° with PVC or bituminous final covering, with or without gravel.

EN
795:2012
E

PVC

TPO

BYTUM

MAXIMUM NUMBER
OF USERS



LOAD DIRECTION



TYPES OF
APPLICATION

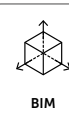

TECHNICAL DATA*

	BLOCK	BLOCK + BLOCKPLATE
maximum number of users		
application on a bituminous base	-	✓
application on PVC	-	✓
application on TPO	-	✓
application in combination with BLOCKMAT	✓	optional
application in combination with BLOCKPLATE	-	✓
number of ballast	24	18
weight	530 kg	400 kg

* The values indicated are the result of experimental tests carried out under the supervision of third parties in accordance with the standards referred to. For a correct calculation report with minimum distances according to the standard requirements, the substructure must be checked by a qualified engineer before installation.

BLOCK | CODES AND DIMENSIONS

CODE	material		B [mm] [in]	H [mm] [in]	L [mm] [in]	pcs	
BLOCK	AISI 304 stainless steel grade 1.4301		1870 73 5/8	165 6 1/2	1645 64 3/4	1	
AOS01	AISI 304 stainless steel grade 1.4301		60 2 3/8	-	98 3 7/8	1	
BLOCKPLATE	AISI 304 stainless steel grade 1.4301		120 4 3/4	120 4 3/4	240 9 7/16	1	
BLOCKMAT	rubber granules thermo-bound with PU	-	550 21 5/8	6 0.24	1050 41 5/16	1	

GREEN POINT

ANCHOR POINT WITH BALLASTS

FAST INSTALLATION

The system consists of few components which facilitate and speeds up mounting.

FUNCTIONAL

Support system which does not require the roofing to be penetrated, thereby preventing thermal bridging and ensuring the structure waterproofing.

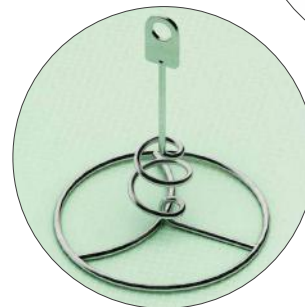
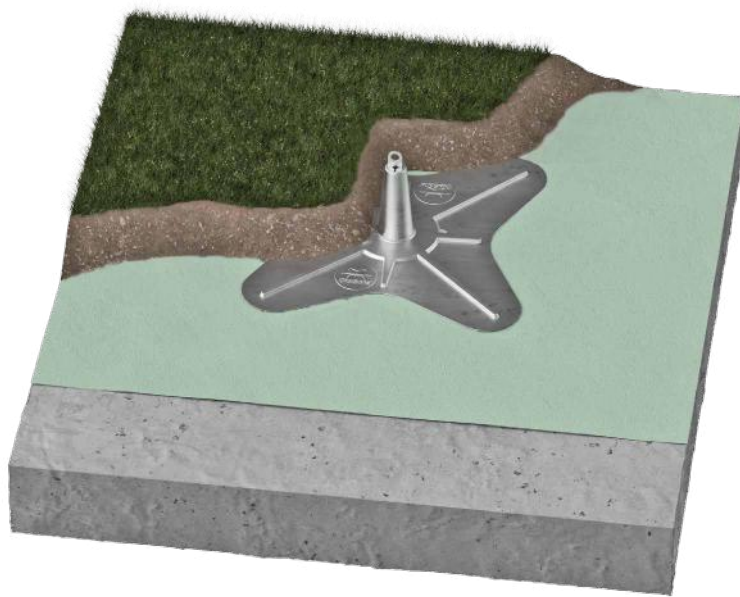

> 80 kg/m ²	> 200 kg/m ²	> 200 kg/m ²
EN 795:2012 A	UNI 11578:2015 A	CEN/TS 18415:2013



MAXIMUM NUMBER OF USERS



LOAD DIRECTION



TYPES OF APPLICATION



TECHNICAL DATA*

no. of operators	dimensions	material weight	total weight
	standard tarpaulin dimensions 3x3 m VLF non-woven geotextile	for ballast > 80 kg/m ²	for each pole = 720 kg
	standard tarpaulin dimensions 3x3 m VLF non-woven geotextile	for ballast > 200 kg/m ²	for each pole = 1800 kg

* They are based on measurements from various test institutes and measurement laboratories. We reserve the right to make technical changes.

CODES AND DIMENSIONS

CODE	description	material		d ₁ [mm] [in]	B [mm] [in]	H [mm] [in]	L [mm] [in]	pcs	
GREENPOINT	anchor point internal element	AISI 316L stainless steel grade 1.4404		250 9.85	- -	300 11 3/4	- -	1	
GREENCARPET	tarpaulin with possibility of installing ballasts 3x3 m with external cone	glass fibre reinforced plastic		- -	3000 118 1/8	- -	3000 118 1/8	1	

GLUE ANCHOR

GLUED ANCHOR POINT FOR BITUMEN AND PVC ROOFS

WATERPROOF

The application does not require any perforation of the PVC or bituminous membrane, guaranteeing perfect waterproofing of the roof.

FAST INSTALLATION

The system is quickly installed with very few tools.



GLUEPVC



GLUEBIT

MAXIMUM NUMBER OF USERS



LOAD DIRECTION



TYPES OF APPLICATION

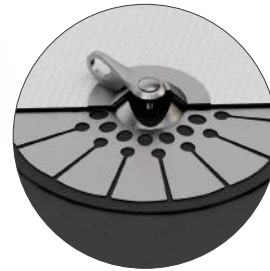

TECHNICAL DATA*

	GLUEPVC	GLUEBIT
substrate material requirement	-	ABB / SBS multilayer bitumen membrane with at least one polyester core PVC / polyester reinforced membrane
substrate tensile strength	≥ 900N/50 mm (EN 12311-2)	340 ± 20% N/50 mm
other substrate requirements	the substrate must be clean, free of dust, moss and algae and dry.	<ul style="list-style-type: none"> mechanically fastened (MF) with a minimum of 3 fasteners per m² ballasted with gravel at least 40 mm thick (approx. 60 kg/m²) partially glued (50% of total surface area) to a mechanically fixed bituminous roof waterproofing system

* The values indicated are derived from experimental tests carried out under the supervision of third party organisations according to the referenced standard. For a calculation report with minimum distances, according to the referenced normative requirements, the substructure must be verified by a qualified engineer before installation. On request, GLUE ANCHOR is also available for other types of membranes.

CODES AND DIMENSIONS

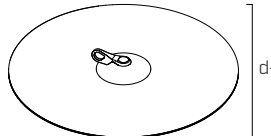
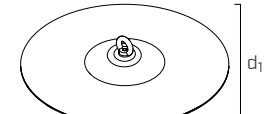
CODE	description	d ₁ [mm] [in]	pcs	
GLUEBIT	glued anchor point for bitumen roof with swivel eyelet max. roof slope 15° minimum surface around the anchor point (from the centre): 1.8 m ambient temperature of use: min. -30° C / max. 90°C	700 27.56	1	
GLUEPVC	glued anchor point for PVC roofs max. roof slope 15° minimum surface around the anchor point (from the centre): 2 m	520 20.48	1	

MOBILE



MOBILE ANCHOR POINT

EN
785 - B

REMOVABLE

It can be assembled and disassembled easily and quickly, to safely ensure access.

MAXIMUM NUMBER
OF USERS



FUNCTIONAL

It can be installed on doors, windows and inclined skylights, with no structural damage.

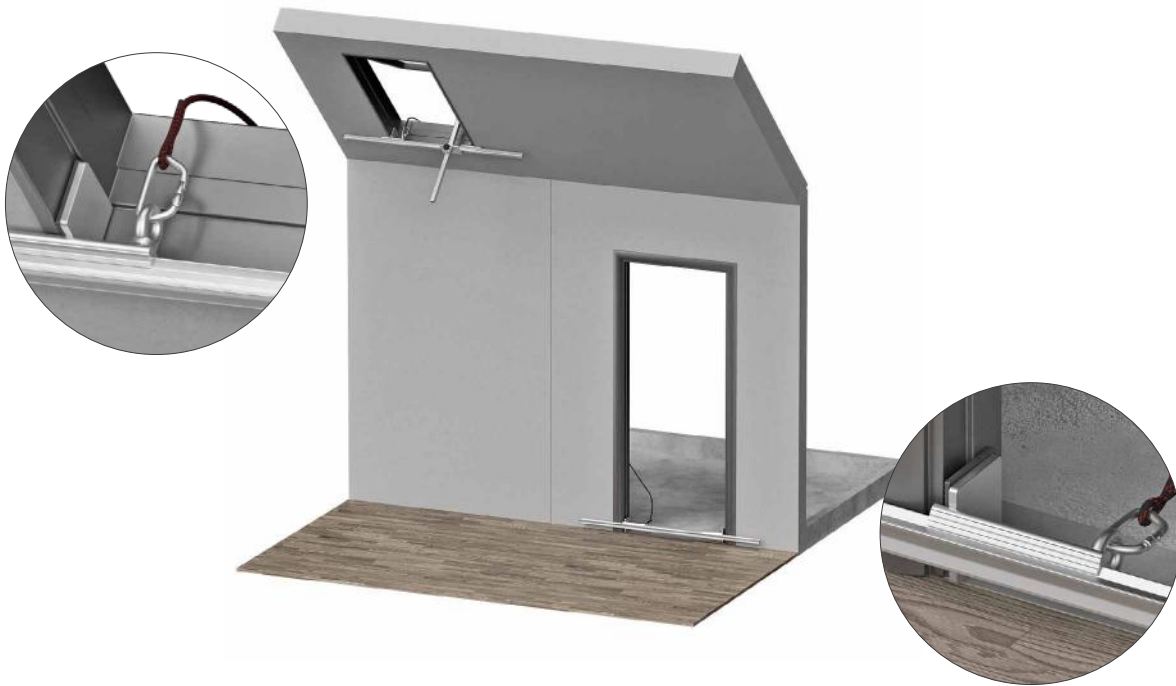

CODES AND DIMENSIONS

CODE	material		L [mm] [in]	B [mm] [in]	H [mm] [in]	weight [kg]	pcs
MOBILE	EE30 aluminium		1450 57 1/16	770 30 5/16	175 6 7/8	6,7	1

The values indicated are the result of experimental tests carried out under the supervision of third parties in accordance with the standard referred to. For a calculation report with minimum distances according to the relevant standard requirements, the substructure must be checked by a qualified engineer before installation.

APPLICATION

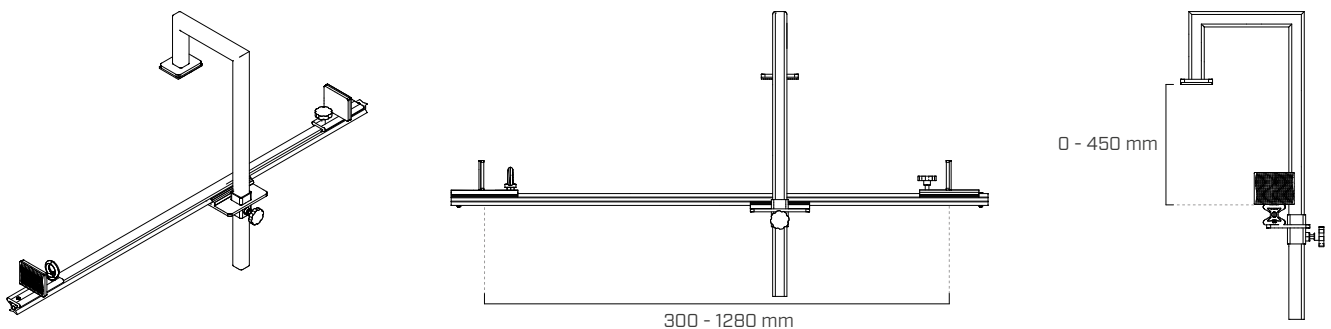

ROD

ANCHOR POINT FOR STEEL STRUCTURES

EN
785-A

PRACTICAL

Thanks to its compact size, this anchor can be installed quickly and easily.

VERSATILE

It can be assembled on tubular and box-type steel structures of different sizes.

MAXIMUM NUMBER
OF USERS

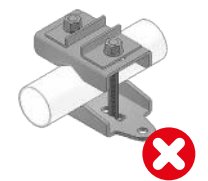
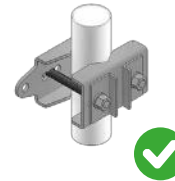
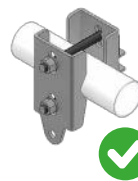
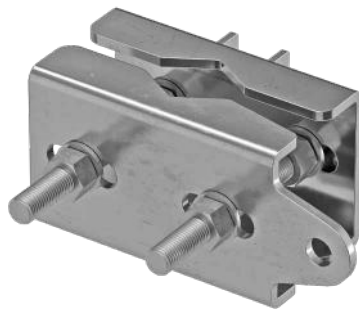

CODES AND DIMENSIONS

CODE	material	dimensions [mm] [in]	anchor point diameter [[mm] [in]	weight [kg]	pcs
ROD	stainless steel	208 x 97 x 75-140 8 3/16 x 3 13/16 x 2 15/16-5 11/16	17 0.67	2,5	1

The values indicated are the result of experimental tests carried out under the supervision of third parties in accordance with the standard referred to. For a calculation report with minimum distances according to the relevant standard requirements, the substructure must be checked by a qualified engineer before installation.

APPLICATIONS

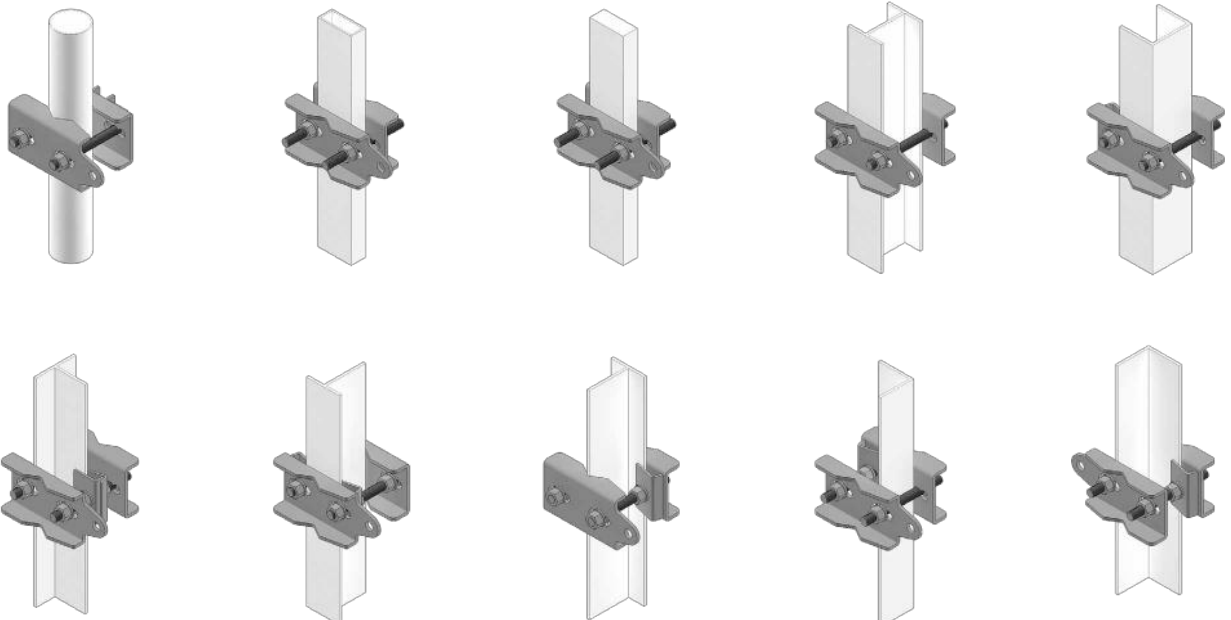

CARRIER



SLIDING ANCHOR FOR STEEL STRUCTURES

FUNCTIONAL

Thanks to the integrated rollers, the device slides smoothly along the entire steel structure.

SIMPLE

Quick and easy to install anchor on steel beams with different widths, from 65 to 120 mm.

EN
795 - B



MAXIMUM NUMBER
OF USERS



LOAD DIRECTION



TYPES OF
APPLICATION

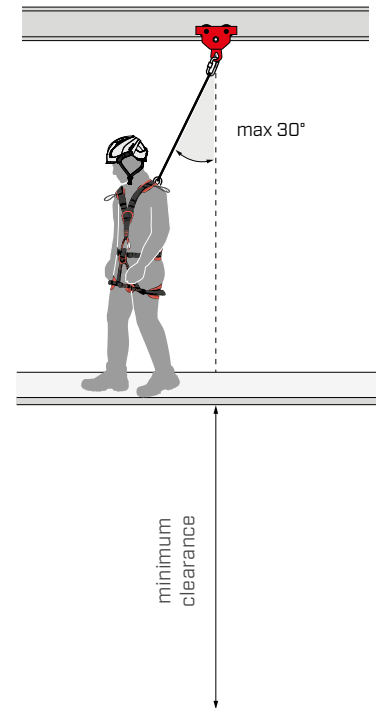
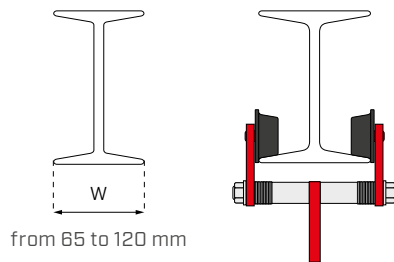
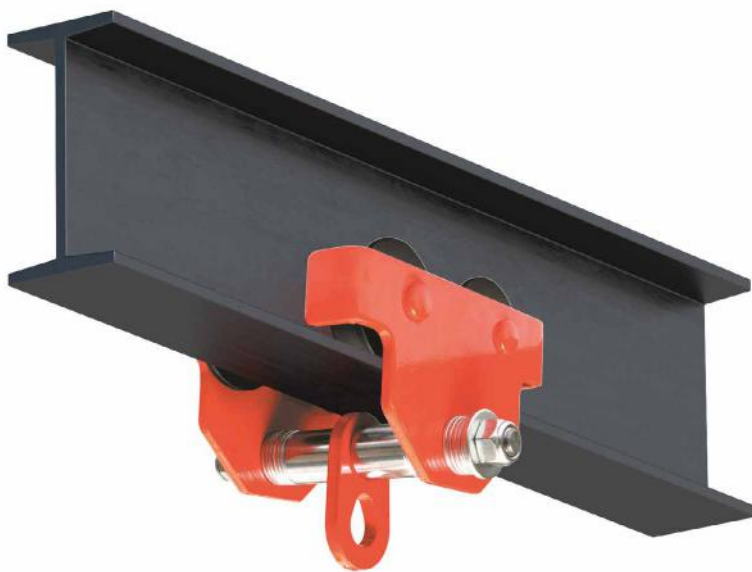

CODES AND DIMENSIONS

CODE	material	dimensions	B	H	weight	pcs
		[mm] [in]	[mm] [in]	[mm] [in]		
CARRIER	zinc plated steel	195 x 176 x 212 7 11/16 x 6 15/16 x 8 3/8	65-120 2 9/16-4 3/4	60 2 3/8	5,2	1

The values indicated are the result of experimental tests carried out under the supervision of third parties in accordance with the standard referred to. For a calculation report with minimum distances according to the relevant standard requirements, the substructure must be checked by a qualified engineer before installation.

RAPTOR



RIGGING DEVICE AND TEMPORARY ANCHOR POINT

ONE PRODUCT – TWO FUNCTIONS

It can be used either as a lifting device to transport timber elements, or as a temporary fall protection anchor point.

VERSATILE

The device is suitable for many different handling configurations. It can be used to work with any inclination, with both tensile and shear stresses.

GOOD VISIBILITY IN THE CONSTRUCTION SITE

The red coating protects the device and ensures good visibility increasing the safety of workers on the construction site.

DIRECTIVE 2006/42/EC	EN 795:2012 A	ANSI* Z359.1B -2017 A	OSHA 1926.753(e)(2) COMPLIANT	ASME BTH-1-2023 COMPLIANT
-------------------------	---------------------	-----------------------------	-------------------------------------	---------------------------------

*The system has been developed and tested in full accordance with the static, dynamic and residual strength requirements outlined in the relative ANSI standard.



MAXIMUM NUMBER OF USERS



LOAD DIRECTION



TYPES OF APPLICATION

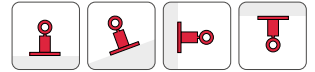

TECHNICAL DATA*

substructure	minimum thickness	fasteners	substructure	minimum thickness	fasteners
CLT	100 mm	HBS PLATE (EVO) Ø10 VGS (EVO) Ø11 + HUS10	GL24h	100 x 120 mm	HBS PLATE (EVO) Ø10 VGS (EVO) Ø11 + HUS10

* The values indicated are the result of experimental tests carried out under the supervision of third parties in accordance with the standards referred to. For a correct calculation report with minimum distances according to the standard requirements, the substructure must be checked by a qualified engineer before installation.

CODES AND DIMENSIONS

CODE	description	B [mm] [in]	H [mm] [in]	L [mm] [in]	pcs
RAP220100	temporary anchor point (maximum capacity 3150 kg)	100 4	107 4 3/16	220 8 5/8	1

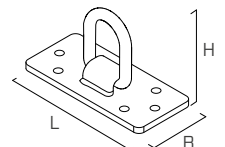

For load values and more detailed information on its use as a transport plate for timber elements, see the technical data sheet in the equipment catalogue and on the website at www.rothoblaas.com.

COLLECTIVE PROTECTION

COLLECTIVE PROTECTION

PERMANENT RAILING BARRIERS



BORDER W

page 140 ◀

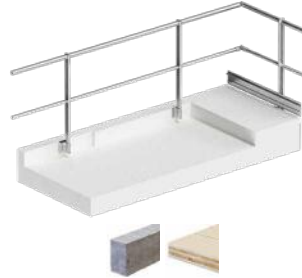

BORDER V/BORDER VD

page 141 ◀

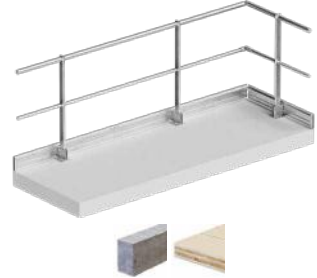

BORDER H

page 142 ◀



BORDER M

page 143 ◀



BORDER Z

page 144 ◀

FIXED LADDERS



STEP UP

page 150 ◀

PITCHED LADDERS



EASY LAD

page 158 ◀



ALL WALK

page 160 ◀

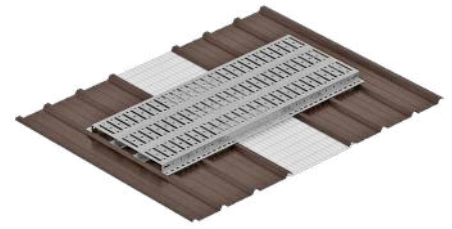

EASY WALK

page 162 ◀



OVERNET

page 164 ◀



ROLLNET

page 166 ◀

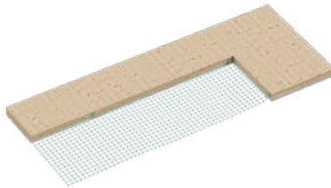

HORIZONTAL NET

page 168 ◀

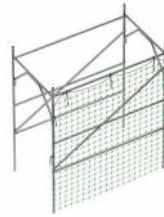

VERTICAL NET

page 170 ◀



FRAME NET

page 171 ◀



EDGE TEMP 1

page 172 ◀



EDGE TEMP 2

page 172 ◀



EDGE TEMP 3

page 173 ◀



EDGE TEMP 4

page 173 ◀



HANG TEMP

page 174 ◀



HANG ROOF

page 174 ◀



HANG WALL

page 175 ◀



HANG PLAIN

page 175 ◀

BORDER

ALUMINIUM PERMANENT AND TEMPORARY RAILINGS

SIMPLE

Featuring easy and fast assembly, it can be installed in just a few steps thanks to the innovative snap-fit system.

COMPATIBLE

The modular system can meet any design requirement thanks to the wide range of available accessories.

AESTHETICS AND DURABILITY

Made of aluminium alloy, the railing guarantees a good corrosion resistance and a pleasing appearance.

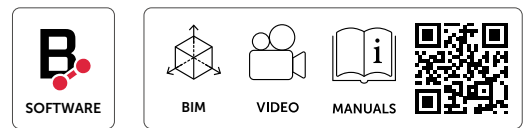

BORDER | TYPES AND KEY ELEMENTS

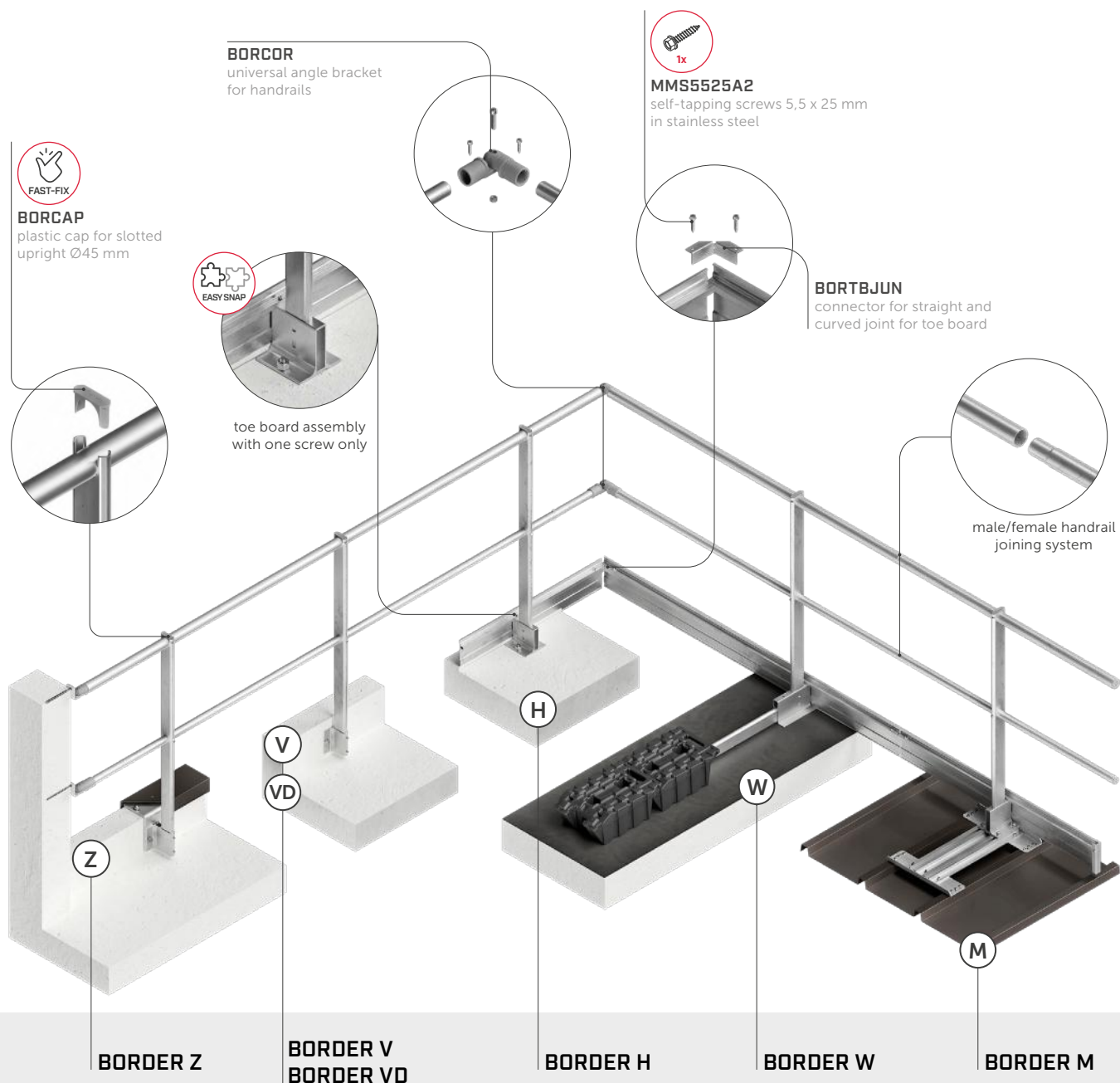

UPRIGHT TYPES



AVAILABLE COLOURS

On request: anodised or powder-coated (RAL colours)

material:
EN AW 6005A-T6



All railing types are available in straight, curved and folding versions. See page 145.

BORDER W

SELF-SUPPORTING RAILING

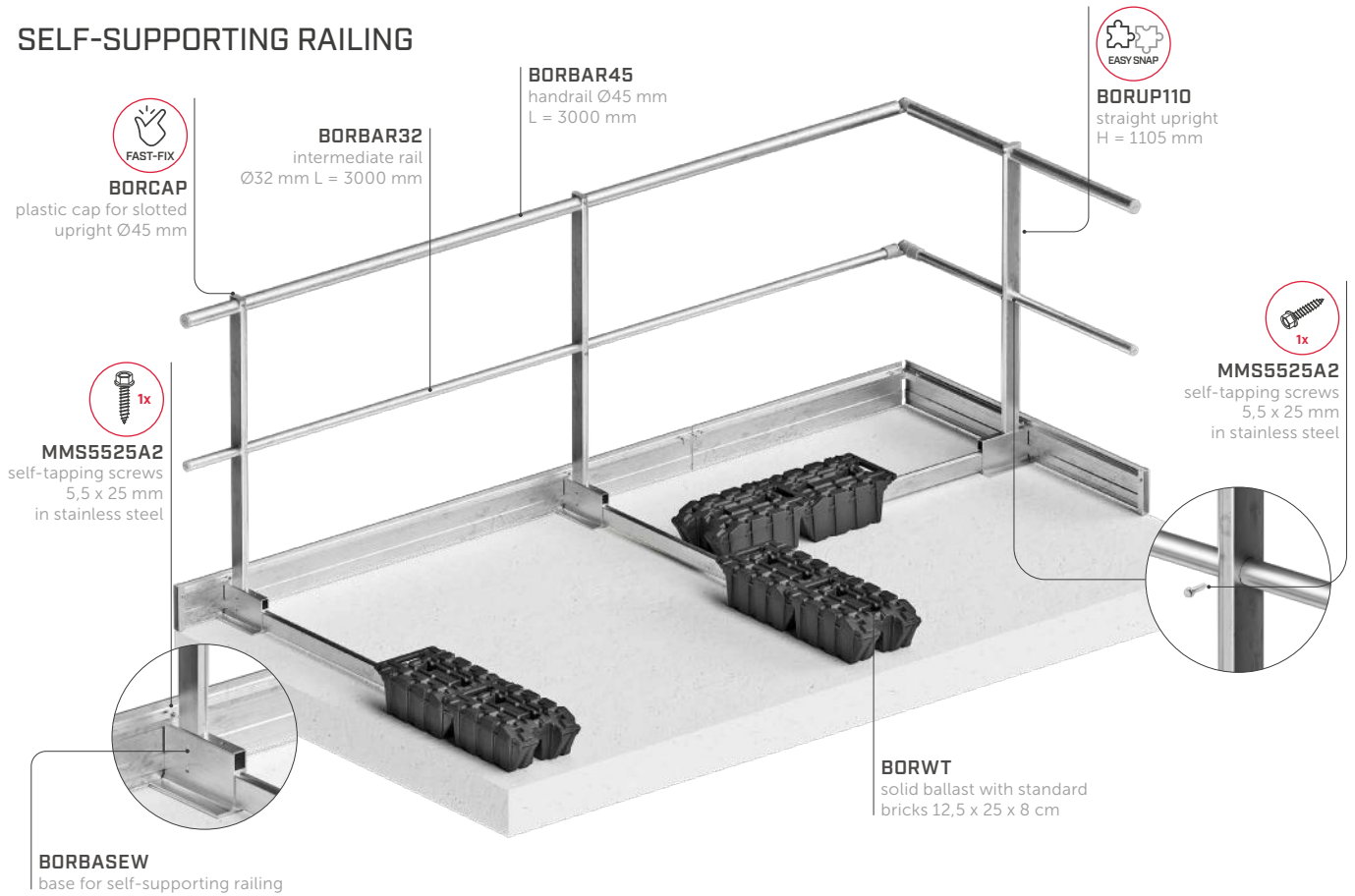

snap-fit cap and upright



rapid installation with snap-fit system, without the need for additional screws



use of only one screw for railing installation



toe board assembly with one screw only

SPACING

upright/frets	H _{uprights}	spacing between uprights [cm]			
		150	100	250	150
straight + folding	110 cm	150	100	250	150
	100 cm	160*	100*	250*	160*
curved	113 cm	145*	100*	250*	145*

* Spacings are interpolated based on the most critical case. See the technical data sheet for spacings related to standards not included in the table.

substructure



C20/25 **CLT** **SHEATH** **PVC**

BORDER W can be installed on all 4 of the substructures without fasteners.

BALLAST TYPES

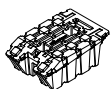

BORWT
ballast with standard bricks 12,5 x 25 x 8 cm weight 12,5 kg

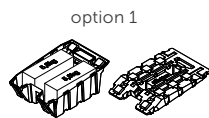

BORWTBOX
option 1
hollow ballast to be filled with 2 bricks measuring 12,5 x 25 x 8 cm (not included)

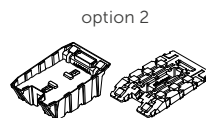

BORWTBOX
option 2
hollow ballast to be filled with concrete or sand

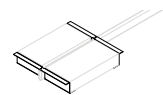

BORWTFRAME
frame for ballast with standard concrete slabs

BORDER V/BORDER VD

RAILING VERTICAL AND VERTICAL SPACED FASTENING

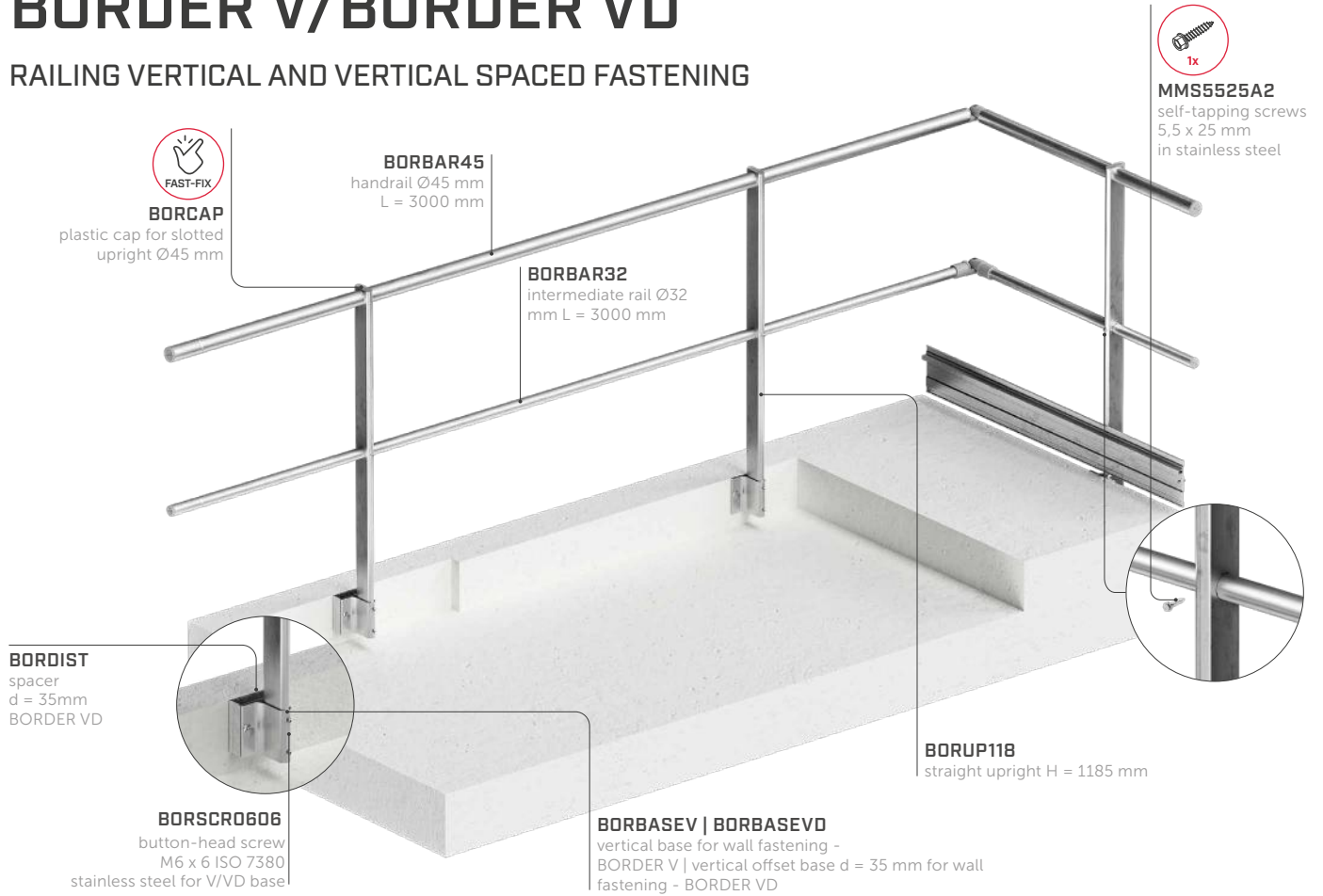

snap-fit cap and upright



use of only one screw for railing installation

SPACING

upright/frets	H _{uprights}	spacing between uprights [cm]			
		EN 14122-3: 2018	NTC 2018 + DLgs.81/08	EN 13374+A1: 2024 A	NF E85-015: 2019
straight	130 cm	150	150	-	150
	118 cm	160*	160*	-	160*
straight + folding	110 cm	165*	170*	250	165*
	100 cm	170*	180*	250*	170*
straight	76 cm	185*	180*	-	185*
curved	113 cm	160*	170*	-	160*

substructure	fasteners
C20/25	AB1 Ø12
	SKR Ø12
	INA Ø12 VIN-FIX

* Spacings are interpolated based on the most critical case. See the technical data sheet for spacings related to standards not included in the table.

BORDER H

HORIZONTAL FASTENING RAILING

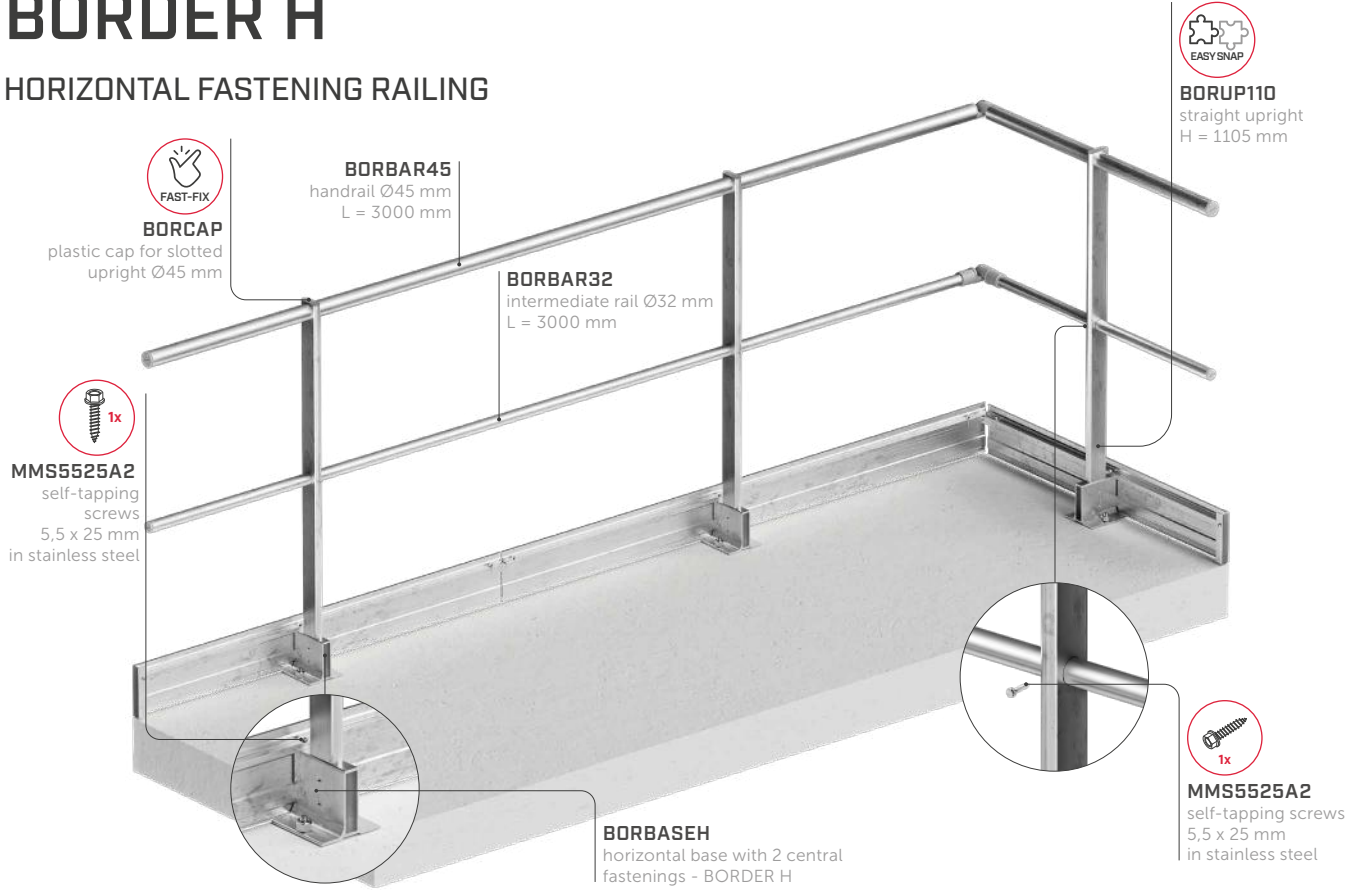

snap-fit cap and upright



rapid installation with snap-fit system, without the need for additional screws



use of only one screw for railing installation



toe board assembly with one screw only

SPACING

upright/frets	H _{uprights}	spacing between uprights [cm]			
		EN 14122-3: 2016	NTC 2018 + DLGS.81/08	EN 13374+A1: 2024 A	NF E85-015: 2019
straight + folding	110 cm	160	180	250	160
	100 cm	170*	180*	250*	170*
straight	53 cm	190*	180*	-	190*
curved	113 cm	155*	180*	-	155*

substructure	fasteners
C20/25	AB1 Ø12
	SKR Ø12
	INA Ø12 VIN-FIX
CLT	VGS Ø13 HUS Ø12

*Spacings are interpolated based on the most critical case. See the technical data sheet for spacings related to standards not included in the table.

BASE H WATERPROOFING KIT

The waterproofing kit (code BORBASEHKIT) consists of washers and gaskets combined with chemical fastening. It ensures waterproofing and prevents water infiltration into the concrete structure.

- ① 1 x EPDM gasket
- ② 2 x EPDM washers for M12
- ③ 2 x washers for M12
- ④ 2 x protective caps for M12 nut

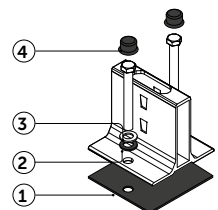

BORDER M

RAILING FASTENING ON TRAPEZOIDAL METAL ROOF

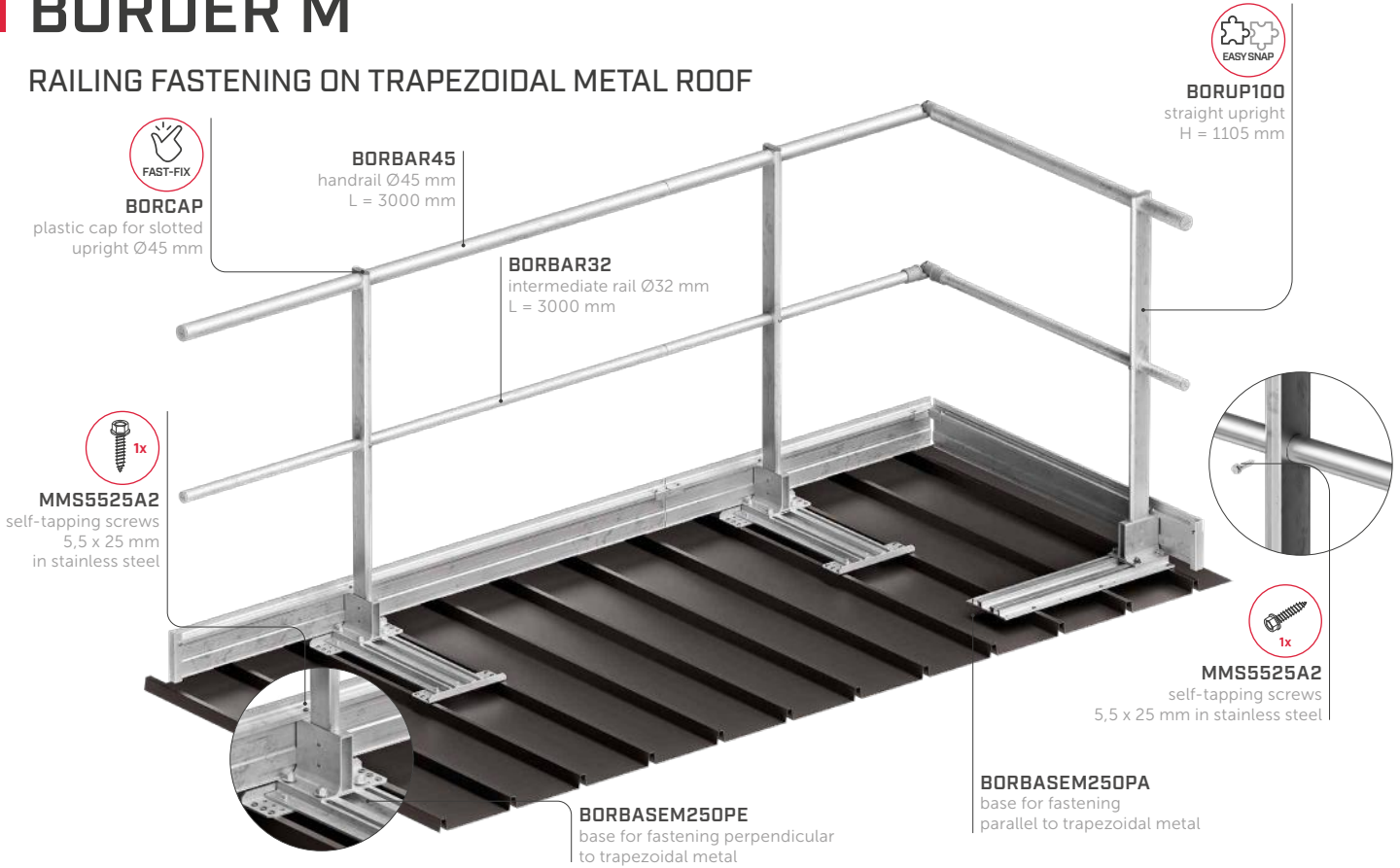

snap-fit cap and upright



rapid installation with snap-fit system, without the need for additional screws



use of only one screw for railing installation



toe board assembly with one screw only

SPACING BY FASTENER TYPE

upright/frets	H _{uprights}	spacing between uprights [cm]				substructure	fasteners
		EN 14122-3: 2016	NTC 2018 + DLGS81/08	EN 13374+A1: 2024 A	NF E85-015: 2019		
straight + folding + fret 250 mm	110 cm	150	-	-	150		rivet 6,3
	100 cm	150*	-	-	150*		
straight + folding + fret 333 mm	110 cm	166	-	-	166		
	100 cm	166*	-	-	166*		

* Spacings are interpolated based on the most critical case. See the technical data sheet for spacings related to standards not included in the table.

BASE TYPES (excluding EPDM gasket and rivets)

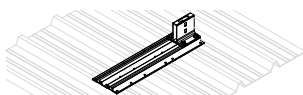

BORBASEM250PA
base for trapezoidal metal for BORDER parallel to the frets, pitch 200 - 250mm

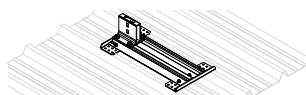

BORBASEM250PE
base for trapezoidal metal for BORDER perpendicular to the frets, pitch 200 - 250mm

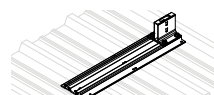

BORBASEM333PA
base for trapezoidal metal for BORDER parallel to the frets, pitch 333 - 350mm

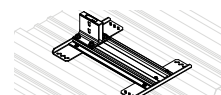

BORBASEM333PE
base for trapezoidal metal for BORDER perpendicular to the frets, pitch 333-350 mm

BORDER Z

A Z FASTENING RAILING

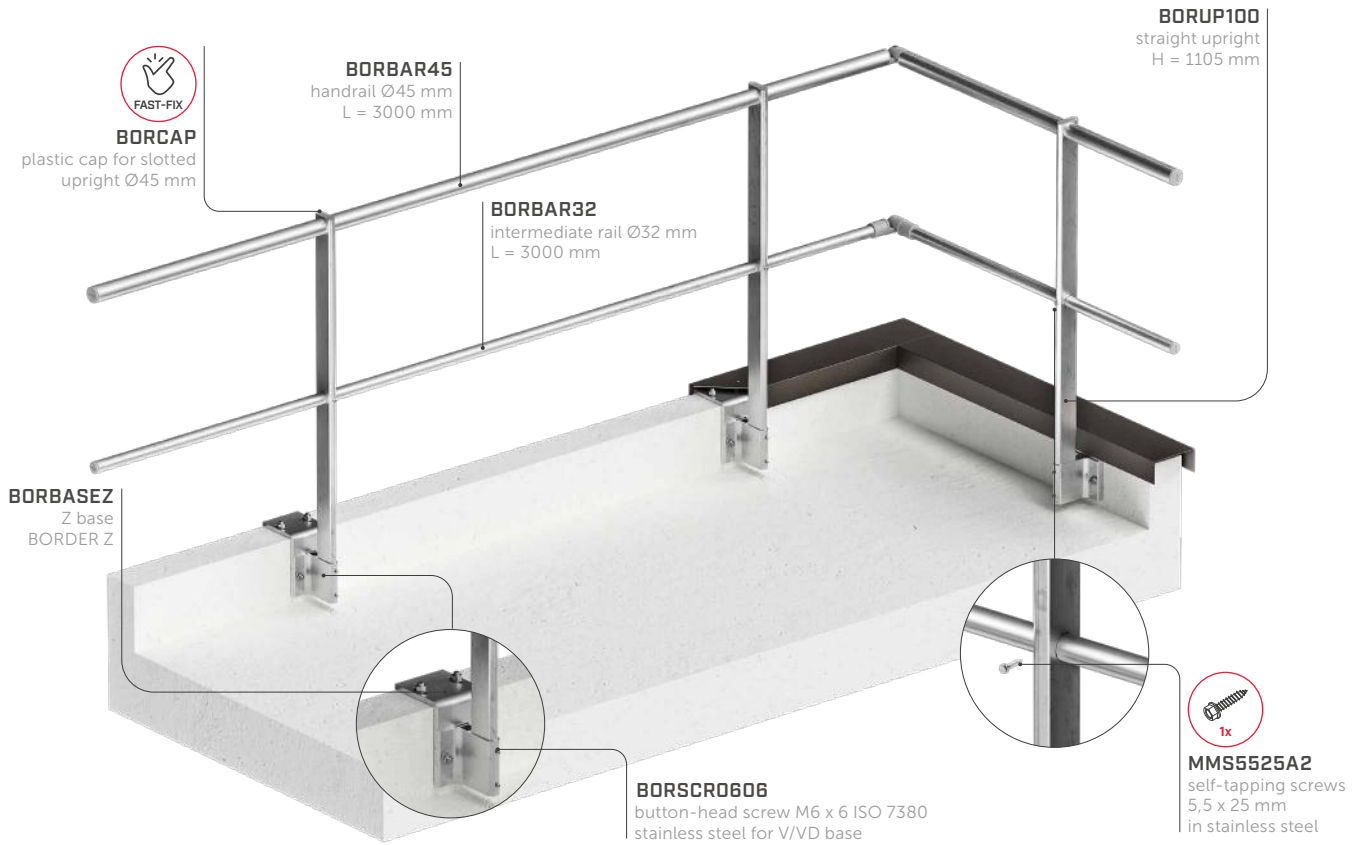

snap-fit cap and upright



use of only one screw
for railing installation



toe board assembly
with one screw only

SPACING

upright/frets	H _{uprights}	spacing between uprights [cm]			
		EN 14122-3: 2016	NTC 2018 + DLgs.81/08	EN 13374-A1: 2024 A	NF E85-015: 2019
straight + folding	110 cm	150	140	-	150
	100 cm	160*	140*	-	160*
curved	113cm	145*	100*	-	145*

* spacings are interpolated based on the most critical case.
See the technical data sheet for spacings related to standards not included in the table.

substructure	fasteners
C20/25	AB1 Ø12
	SKR Ø12
	INA Ø12 VIN-FIX

BASE TYPES



BORBASEZ
for kerb without insulation layer



BORBASEZ70
for kerb with 70 mm thick insulation layer



BORBASEZ100
for kerb with 100 mm thick insulation layer







BORBASEZ130
for kerb with 130 mm thick insulation layer















BORBASEZ160
for kerb with 160 mm thick insulation layer

BORDER | components

RAILS | CODES AND DIMENSIONS

CODE	description	d [mm] [in]	L [mm] [in]	pcs	
BORBAR45	tapered handrail	45 1.77	3000 118 1/8	1	
BORBAR32	tapered intermediate rail	32 1.26	3000 118 1/8	1	
BORBAR45F	handrail for folding railing	45 1.77	3000 118 1/8	1	
BORBAR32F	non-tapered intermediate rail for folding railing	32 1.26	3000 118 1/8	1	
BORBAR45R	tapered and reinforced handrail	45 1.77	3000 118 1/8	1	

UPRIGHTS | CODES AND DIMENSIONS

CODE	description	H [mm] [in]	pcs	
BORUP530WH	straight upright without holes for intermediate rail	535 21 1/16	1	
BORUP760WH	straight upright without holes for intermediate rail	765 30 1/8	1	
BORUP100	straight upright	1005 39 9/16	1	
BORUP110	straight upright	1105 43 1/2	1	
BORUP118	straight upright	1185 46 5/8	1	
BORUP130	straight upright	1305 51 3/8	1	
BORUP100F	folding upright	1005 39 9/16	1	
BORUP110F	folding upright	1105 43 1/2	1	
BORUP113C	15° curved upright	1125 44 5/16	1	
BORUP100R	reinforced straight upright for EN 13374 and BS 13700	1005 39 9/16	1	
BORUP110R	reinforced straight upright for EN 13374 and BS 13700	1105 43 1/2	1	
BORUP100AS	straight upright (AS 1657:2018)	1005 39 9/16	1	
BORUP107US	straight upright (OSHA 1910.29)	1075 42 5/16	1	

BORDER | components

TOE BOARD | CODES AND DIMENSIONS

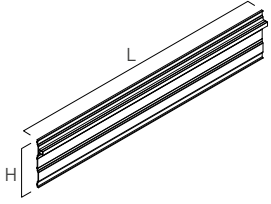
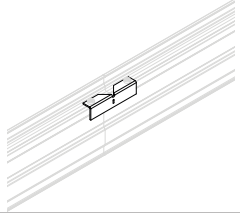
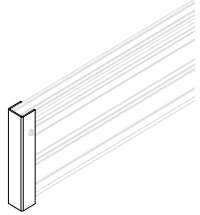
CODE	description	H [mm] [in]	L [mm] [in]	pcs	
BORTB	toe board	150 6	3000 118 1/8	1	
BORTBJUN	connector for straight and curved joint for toe board	-	-	1	
BORTBCAP	end cap for toe board	-	-	1	

BASES | CODES AND DIMENSIONS

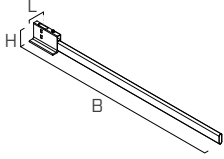
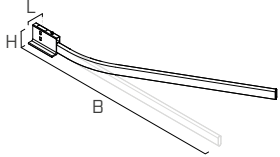
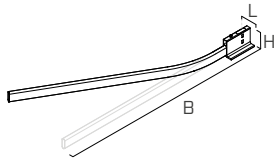
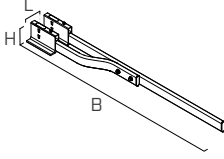
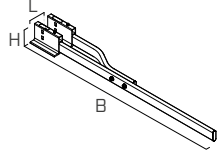
CODE	description	B [mm] [in]	H [mm] [in]	L [mm] [in]	pcs	
BORBASEW	base for self-supporting railing - BORDER W	1400 55 1/8	115 4 1/2	100 4	1	
BORBASEWFCL	base for left-hand folding self-supporting curve - BORDER W	1400 55 1/8	115 4 1/2	100 4	1	
BORBASEWFCR	base for right-hand folding self-supporting curve - BORDER W	1400 55 1/8	115 4 1/2	100 4	1	
BORBASEWFL	base for left-hand folding self-supporting railing - BORDER W	750 29 1/2	115 4 1/2	100 4	1	
BORBASEWFR	base for right-hand folding self-supporting railing - BORDER W	750 29 1/2	115 4 1/2	100 4	1	

BORDER | components

BASES | CODES AND DIMENSIONS

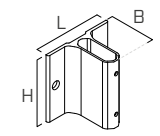
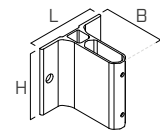
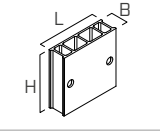
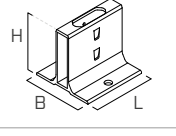
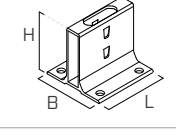
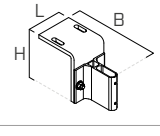
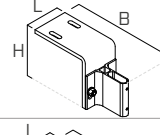
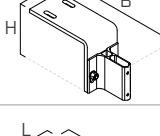
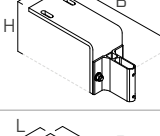
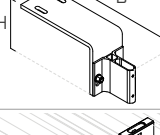
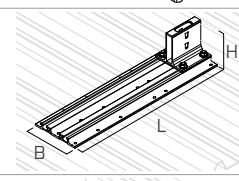
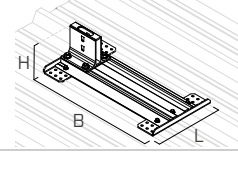
CODE	description	B [mm] [in]	H [mm] [in]	L [mm] [in]	pcs	
BORBASEV	vertical base for wall fastening - BORDER V	80 3 1/8	115 4 1/2	120 4 3/4	1	
BORBASEVD	vertical offset base d = 35 mm for wall fastening - BORDER VD	107 4 3/16	115 4 1/2	120 4 3/4	1	
BORDIST	spacer d = 35 mm - BORDER VD	35 1 3/8	115 4 1/2	120 4 3/4	1	
BORBASEH	horizontal base with 2 central fastenings - BORDER H	120 4 3/4	115 4 1/2	125 4 15/16	1	
BORBASEH4H	horizontal base with 4 fastenings for timber roofs - BORDER H	120 4 3/4	115 4 1/2	125 4 15/16	1	
BORBASEZ	Z-base for kerb without insulation layer - BORDER Z	250 10	167 6 9/16	120 4 3/4	1	
BORBASEZ70	Z-base for kerb with 70 mm thick insulation layer - BORDER Z	310 12 3/16	167 6 9/16	120 4 3/4	1	
BORBASEZ100	Z-base for kerb with 100 mm thick insulation layer - BORDER Z	340 13 3/8	167 6 9/16	120 4 3/4	1	
BORBASEZ130	Z-base for kerb with 130 mm thick insulation layer - BORDER Z	370 14 9/16	167 6 9/16	120 4 3/4	1	
BORBASEZ160	Z-base for kerb with 160 mm thick insulation layer - BORDER Z	400 15 3/4	167 6 9/16	120 4 3/4	1	
BORBASEM250PA	base for trapezoidal metal for BORDER parallel to the frets, pitch 200-250 mm - BORDER M	175 6 7/8	140 5 1/2	630 24 13/16	1	
BORBASEM250PE	base for trapezoidal metal for BORDER perpendicular to the frets, pitch 200-250 mm - BORDER M	540 21 1/4	143 5 5/8	280 11	1	

BORDER | components

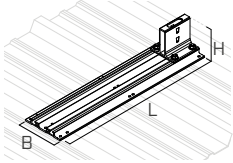
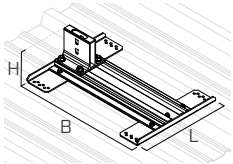

BASES | CODES AND DIMENSIONS

CODE	description	B [mm] [in]	H [mm] [in]	L [mm] [in]	pcs	
BORBASEM333PA	base for trapezoidal metal for BORDER parallel to the frets, pitch 333 - 350mm - BORDER M	175 6 7/8	140 5 1/2	730 28 3/4	1	
BORBASEM333PE	base for trapezoidal metal for BORDER perpendicular to the frets, pitch 333 - 350 mm - BORDER M	540 21 1/4	143 5 5/8	380 15	1	

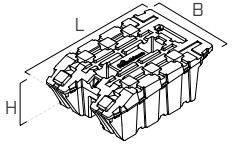
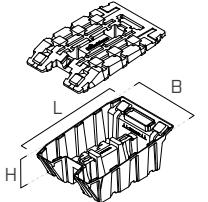
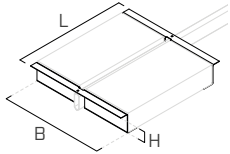
BALLAST | CODES AND DIMENSIONS



CODE	description	B [mm] [in]	H [mm] [in]	L [mm] [in]	pcs	
BORWT	recycled PP plastic-coated ballast, weight 12,5 kg	265 10 7/16	50 1 15/16	400 15 3/4	1	
BORWTBOX	recycled PP plastic container for ballast for bricks or free-flowing material (concrete or sand)	265 10 7/16	50 1 15/16	400 15 3/4	1	
BORWTFRAME	frame for ballast with concrete slabs	570 22 7/16	80 3 1/8	530 20 7/8	2	

ACCESSORIES | CODES AND DIMENSIONS

CODE	description	pcs	
BORCAP45	plastic cap for handrail Ø45 mm (Ø1.77 inch)	1	
BORCAP32	plastic cap for intermediate rail Ø32 mm (Ø1.26 inch)	1	
BORCAP	plastic cap for slotted upright Ø45 mm (Ø1.77 inch)	1	

BORDER | components

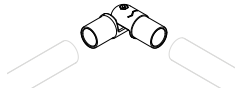
ACCESSORIES | CODES AND DIMENSIONS

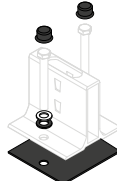
CODE	description	pcs	
BORCOR	universal angle bracket for handrail and rails	1	
BORWALL	universal wall-mounted end element for handrail and rails	1	
BORBASEHKIT	waterproofing kit for BORDER H base	1	

SAFETY GATE | CODES AND DIMENSIONS

CODE	description	L [mm] [in]	H [mm] [in]	pcs	
BORGATE600	safety gate with mounted hinges	600 23 5/8	630 24 13/16	1	

INSTALLATION FASTENERS | CODES AND DIMENSIONS

CODE	description	d [mm] [in]	H [mm] [in]	pcs	
MMS5525A2	self-tapping screw A2 Ø5,5 x 25 mm	5,5 0.22	25 1	50	

TECHNICAL MANUALS | CODES AND DIMENSIONS

CODE	description	pcs	
BORMANW	manual for BORDER W	1	
BORMANV	manual for BORDER V/VD	1	
BORMANH	manual for BORDER H	1	
BORMANM	manual for BORDERM	1	
BORMANZ	manual for BORDER Z	1	

STEP UP

CAGED LADDERS

DURABLE

Made of aluminium alloy, they offer high mechanical resistance and resist corrosion and environmental conditions.

RELIABLE

They guarantee the utmost safety for the user and give the installer the serenity that comes with a reliable product that is easy to assemble.

COMPATIBLE

Thanks to the wide range of available components, the modular system can meet any design requirement.

UNI
11962:2024

D.Lgs.
81/2008

EN 14122-4



VIDEO



MANUALS



STEP UP LADDER COMPONENTS



STEPLAND500
500 mm platform kit
with side protection



STEPBRAF150
pair of mounting brackets for a
150 mm wall distance



STEPDOURIT
splitting rod
Legislative Decree
81/2008

STEPBOARIT
splitting platform
Legislative Decree
81/2008

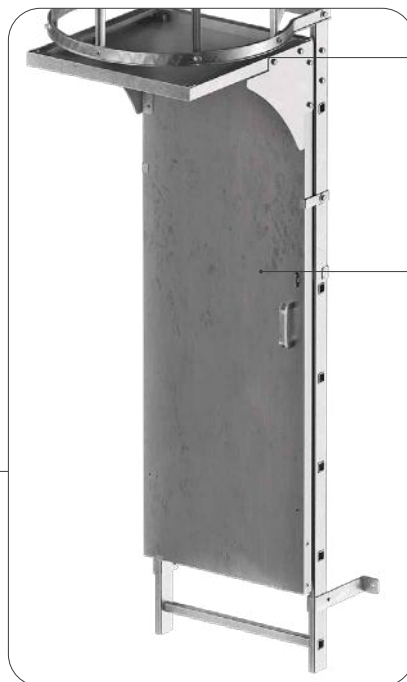



STEPDOORUP
upper part of safety door

STEPDOOR180
safety door

STEP UP | components

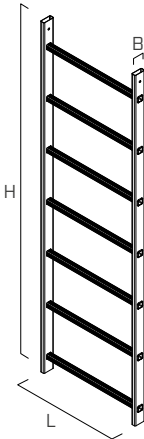
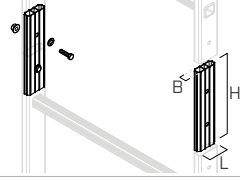
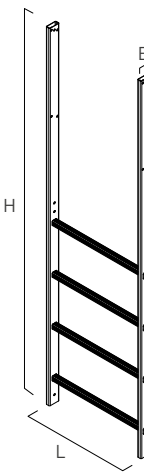
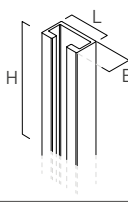

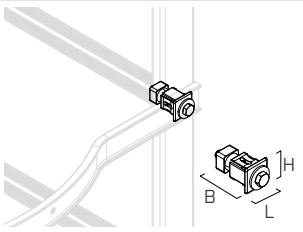
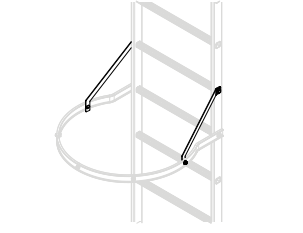
CODES, DESCRIPTIONS AND DIMENSIONS

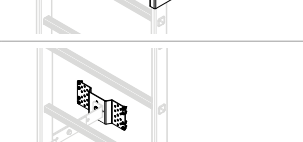
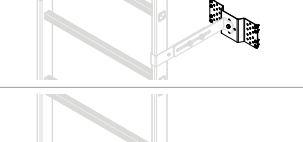
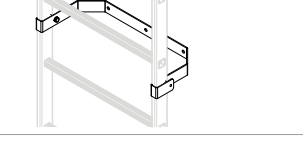

GROUP	CODE	description	B	L	H	pcs	
			[mm] [in]	[mm] [in]	[mm] [in]		
LADDER MODULES	STEPMOD120	ladder module 1,20 m - 4 steps	65 2 9/16	636 25	1200 47 1/4	1	
	STEPMOD150	ladder module 1,50 m - 5 steps	65 2 9/16	636 25	1500 59 1/16	1	
	STEPMOD180	ladder module 1,80 m - 6 steps	65 2 9/16	636 25	1800 70 7/8	1	
	STEPMOD210	ladder module 2,10 m - 7 steps	65 2 9/16	636 25	2100 82 11/16	1	
	STEPMOD240	ladder module 2,40 m - 8 steps	65 2 9/16	636 25	2400 94 1/2	1	
	STEPMODJUN	pair of ladder-to-ladder joints	21 13/16	62 2 7/16	240 9 1/2	1	
FRONT EXIT RAILS	STEPOUT160	module with front exit rail 1,6 m - 2 steps	65 2 9/16	636 25	1595 62 5/8	1	
	STEPOUT190	module with front exit rail 1,9 m - 3 steps	65 2 9/16	636 25	1895 74 7/16	1	
	STEPOUT220	module with front exit rail 2,2 m - 4 steps	65 2 9/16	636 25	2195 86 1/4	1	
	STEPOUT250	module with front exit rail 2,5 m - 5 steps	65 2 9/16	636 25	2495 98 7/16	1	
	STEPOUTJUN	pair of ladder joints-front exit rail	21 13/16	62 2 7/16	240 9 1/2	1	
CAGE	STEPBAR180	kit of 5 cage bars 1,8 m	26,5 1 1/16	15 9/16	1800 70 7/8	1	
	STEPBAR220	kit of 5 cage bars 2,2 m	26,5 1 1/16	15 9/16	2200 86 5/8	1	
	STEPBAR250	kit of 5 cage bars 2,5 m	26,5 1 1/16	15 9/16	2500 98 7/16	1	
	STEPBARJUN	kit with 5 rod joints for cage	18 11/16	22 7/8	80 3 1/8	1	

GROUP	CODE	description	B	L	H	pcs	
			[mm] [in]	[mm] [in]	[mm] [in]		
RINGS	STEPRINGIT	cage ring Leg. Decree 81/2008 - UNI 11962:2024	660 26	636 25	44 1 3/4	1	
	STEPRINGEU	cage ring EN 14122	760 29 15/16	636 25	44 1 3/4	1	
	STEPRINGJUN	pair of ladder-to-ring joints for cage	36 1 7/16	61 2 3/8	36 1 7/16	1	
	STEPSUPRING	pair of reinforcements between steps and safety cage	340 13 3/8	51 2	340 13 3/8	1	
BRACKETS	STEPBRAV150	pair of mounting brackets for a 150 mm wall distance	269 10 1/2	88 3 7/16	50 1 15/16	1	
	STEPBRAV400	pair of mounting brackets for an adjustable wall distance - max. 400 mm	474 18 1/2	88 3 7/16	55 2 3/16	1	
	STEPBRAV600	pair of mounting brackets for an adjustable wall distance - max. 600 mm	674 26 3/8	88 3 7/16	55 2 3/16	1	
	STEPBRAMET	pair of mounting plates for trapezoidal metal (fasteners included)	150 6	358 14	32 1 1/4	1	
	STEPBRAU	"U"-bracket for connecting the ladder to a column or the wall	269 10 1/2	645 25 3/8	50 1 15/16	1	

STEP UP | components

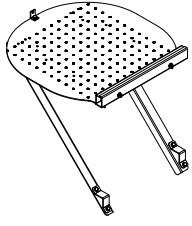
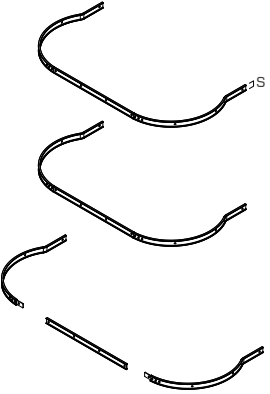
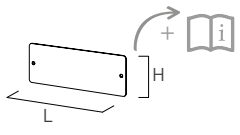
CODES, DESCRIPTIONS AND DIMENSIONS

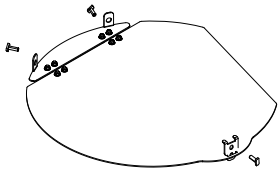
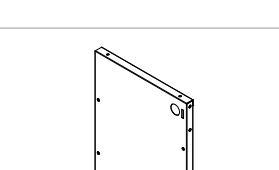
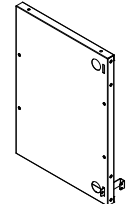
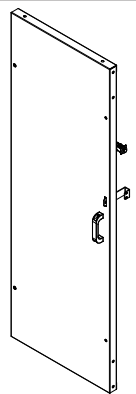
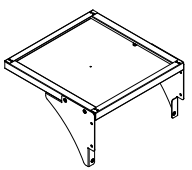
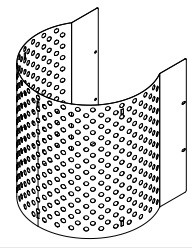
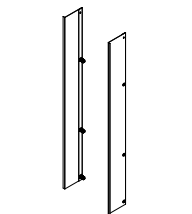
GROUP	CODE	description	pcs	
CAPS	STEPMODCAP	pair of upper upright caps	1	
	STEPBARCAP	kit with 5 rod caps	1	
SPLITTING PLATFORM	STEPBOARIT	splitting platform Legislative Decree 81/2008 - UNI 11962:2024	1	
	STEPBOAREU	splitting platform EN 14122	1	
	STEPDOURIT	splitting rod Leg. Decree 81/2008 - UNI 11962:2024	1	
STEPDOUREU	splitting rod EN 14122	1		
LABEL	STEPTARGAIT	label Leg. Decree 81/2008 - UNI 11962:2024 + IT manual	1	
	STEPTARGAEU	label EN 14122-4 + EN manual	1	

GROUP	CODE	description	pcs	
LADDER ACCESS	STEPTRAPIT	safety gate for ladder access Legislative Decree 81/2008 - UNI 11962:2024	1	
	STEPTRAPEU	safety gate for ladder access EN 14122	1	
	STEPDOOR90	half-height safety door complete with fasteners and door stop	1	
	STEPDOOR180	safety door	1	
	STEPDOORUP	upper part of safety door	1	
COVER	STEPCOVERIT	metal sheet to cover the safety cage Legislative Decree 81/2008 - UNI 11962:2024	1	
	STEPCOVEREU	metal sheet to cover the safety cage EN 14122	1	
	STEPCOVERSIDE	pair of side cage covers	1	

STEP UP | components

CODES, DESCRIPTIONS AND DIMENSIONS

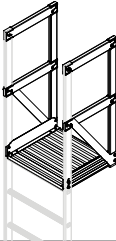
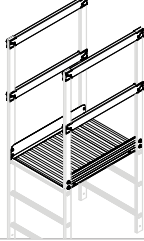
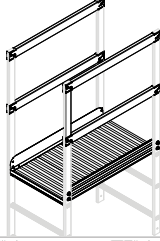
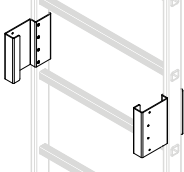
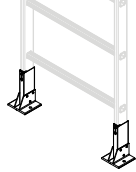
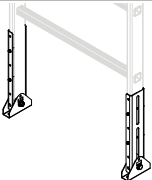
GROUP	CODE	description	pcs	
PROTECTION KIT	STEPLAND300	300 mm platform kit with side protection	1	
	STEPLAND500	500 mm platform kit with side protection	1	
	STEPLAND800	800 mm platform kit with side protection	1	
	STEPLAND1000	1000 mm platform kit with side protection	1	
ACCESSORIES	STEPDOORDIST	door spacers for vertical lifeline	1	
BASES	STEPFEETREG	pair of adjustable support feet with holes for possible ground fastening	1	
	STEPFEETHING	pair of hinged feet with adjustable supports	1	

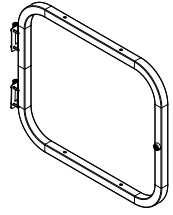
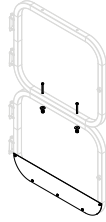
GROUP	CODE	description	pcs	
GATES	STEPGATE550	landing gate H=550 mm (fasteners included)	1	
	STEPGATEKIT	fastening kit for duplication of STEPGATE550 gate	1	

Screws, joints, caps always included in the single codes.

LADDER COMPOSITION INDICATIONS

- Applicable regulations (Leg. Decree 81/2008 - UNI 11962:2024 - EN 14122-4 - local regulations) must be defined by the project engineer
- Choice of components according to the regulations applied
- Start of cage between 2200 and 3000 mm
- Max. distance to next rings 1500 mm
- First bracket between 300 and 600 mm.
- Max. distance to next brackets 2400 mm

To make the system certifiable and obtain more detailed information on the various product installations, it is essential to follow the manufacturer's instructions.

Other components are available on request.

For the composition, use the handbook or the component spreadsheet, both available on our website: www.rothoblaas.com.

EASY LAD

PITCHED LADDER

DLgs.
81/2008

EN 131

SIMPLE

Pre-assembled ladder made of aluminium alloy, making transport and installation easier thanks to its lightweight design.

ERGONOMIC

The 85 mm deep steps, handrail and 70° incline ensure safe and comfortable access.

VERSATILE

Equipped with handrails, fastening hooks and landing handles, it enables access to mezzanine levels, shelving and machinery. It is available in various heights, ranging from 205 cm to 595 cm.



CODES AND DIMENSIONS

CODE	description	B	L	H	no. of steps	pcs
		[mm] [in]	[mm] [in]	[mm] [in]		
ELAD200	straight ladder with 70° incline H= 2,0 m with fixed handrails	210 8 1/4	450 17 3/4	2050 80 5/7	6	1
ELAD250	straight ladder with 70° incline H= 2,5 m with fixed handrails	210 8 1/4	450 17 3/4	2650 104 1/3	8	1
ELAD300	straight ladder with 70° incline H= 3,0 m with fixed handrails	210 8 1/4	450 17 3/4	2950 116 1/7	9	1
ELAD350	straight ladder with 70° incline H= 3,5 m with fixed handrails	210 8 1/4	450 17 3/4	3550 139 3/4	11	1
ELAD400	straight ladder with 70° incline H= 4,0 m with fixed handrails	210 8 1/4	450 17 3/4	4110 161 4/5	13	1
ELAD450	straight ladder with 70° incline H= 4,5 m with fixed handrails	210 8 1/4	450 17 3/4	4450 175 1/5	14	1
ELAD500	straight ladder with 70° incline H= 5,0 m with fixed handrails	210 8 1/4	450 17 3/4	5050 198 4/5	16	1
ELAD550	straight ladder with 70° incline H= 5,5 m with fixed handrails	210 8 1/4	450 17 3/4	5610 220 6/7	18	1
ELAD600	straight ladder with 70° incline H= 6,0 m with fixed handrails	210 8 1/4	450 17 3/4	5950 234 1/4	19	1

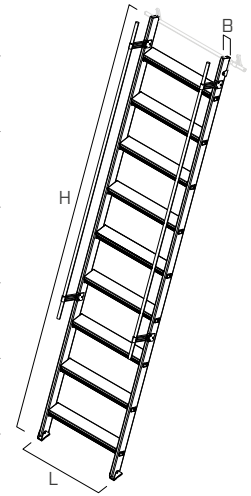

COMPLEMENTARY PRODUCTS

	CODE	description	pcs
HOOKS	ELADHOOKL	long hook for vertical support	1
	ELADHOOKS	standard short hook	1
HANDLES	ELADHANDSC	pair of horizontal handles with interlocks	1
	ELADHANDSV	pair of vertical handles with interlocks	1
SPACERS	ELADDIST	pair of 200 mm spacers	1
SUPPORTS	ELADWHEELS	pair of wheels for side sliding	1
	ELADBAR25	Ø25 rung for attaching the ladder	by the metre
	ELADBRA	bracket to mount the rung on the wall	1

I ALL WALK

WALKWAYS AND OVERPASS

MODULAR

Standard modules to create safe and effective walkways and overpass systems, with or without railings.

ADAPTABLE

Specific supports for the most common types of roofs and substructures allow the product to be adapted to various needs.

LIGHT

The system, made of aluminium alloy, is lightweight and easy both to transport and install.

EN
14122-3

EN
14122-2

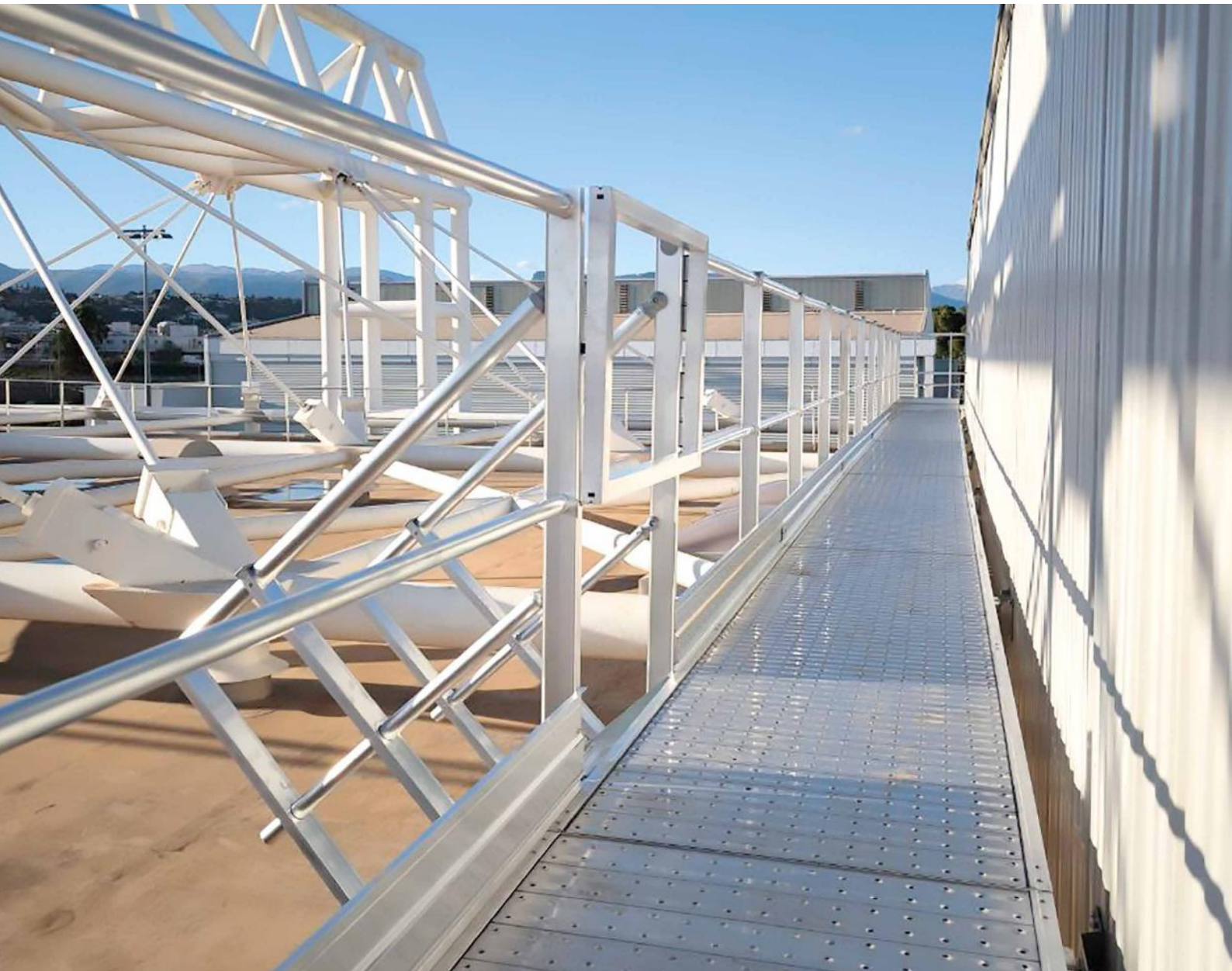

TYPE OF SYSTEMS

WALKWAYS WITH HORIZONTAL AND INCLINED FASTENING



WALKWAYS WITH FASTENING ON TRAPEZOIDAL METAL



WALKWAYS WITH SIDE FASTENING

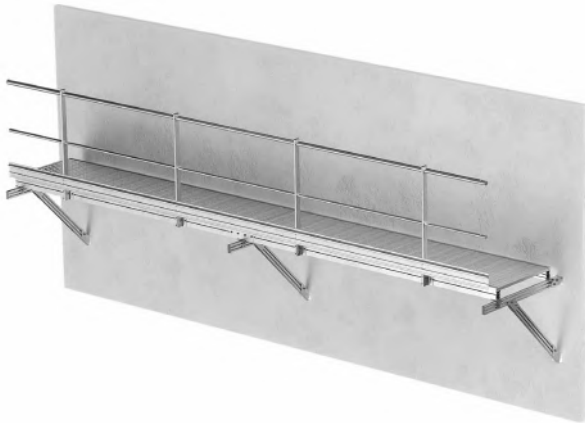

WALKWAYS



INCLINED LADDER

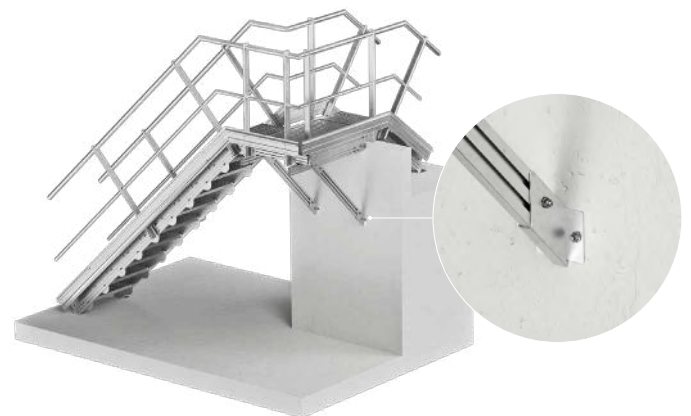

GUIDELINES FOR COMPOSITION OF WALKWAYS AND OVERPASSES

- Tailor-made solutions to meet every design requirement.
- Fastening systems and types are interchangeable.
- Applicable standards (EN 14122-3, EN 14122-2, local regulations) must be determined by the project engineer.
- All systems are compatible with the BORDER railing.
- Standard available widths for walkways and overpasses: 600, 800, 1000 and 1200 mm.
- Standard available widths for inclined ladders: 600 and 800 mm.
- Other systems and solutions are available on request.

EASY WALK

WALKWAYS SYSTEMS FOR TRAPEZOIDAL METAL SHEET ROOFS

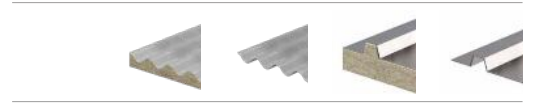

SIMPLE

Pre-assembled standard modules and fastening kits allow rapid installation in just a few steps, using standard equipment.

SAFE

Designed with a non-slip surface and to withstand loads up to a maximum of 2 kN/m², making your roof accessible on foot. Ideal for use in combination with OVERNET.

DURABLE

A system composed of steel walkways with a zinc-aluminium-magnesium coating (Magnelis), aluminium profiles, stainless steel fasteners and EPDM gaskets ensures durability and guaranteed waterproofing.



EASY WALK COMPONENTS

WALKWAY PERPENDICULAR TO FRETS

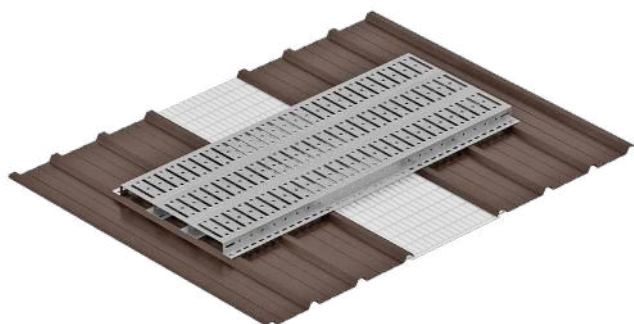

WALKWAY PARALLEL TO FRETS

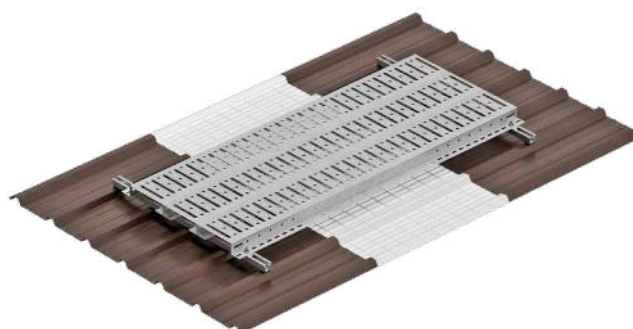

CODES AND DIMENSIONS

CODE	description	B [mm] [in]	L [mm] [in]	H [mm] [in]	weight [kg]	pcs	
EW40150	walkway 400 x 1500 mm (screws and EPDM gasket included)	400 15 3/4	1500 59 1/16	55 2 3/16	14,3	1	
EW40300	walkway 400 x 3000 mm (screws and EPDM gasket included)	400 15 3/4	3000 118 1/8	55 2 3/16	27,5	1	
EW60150	walkway 600 x 1500 mm (screws and EPDM gasket included)	600 23 5/8	1500 59 1/16	55 2 3/16	21,4	1	
EW60300	walkway 600 x 3000 mm (screws and EPDM gasket included)	600 23 5/8	3000 118 1/8	55 2 3/16	41,3	1	
EW20150INT	200 mm intermediate module to widen EW60150	200 8	1500 59 1/16	55 2 3/16	7,15	1	
EW20300INT	200 mm intermediate module to widen EW60300	200 8	3000 118 1/8	55 2 3/16	10,7	1	
EW70SUP2	kit with 2 supports for EW40150 for installation parallel to the frets	40 1 9/16	700 27 1/2	30 1 3/16	0,98	2	
EW70SUP3	kit with 3 supports for EW40300 for installation parallel to the frets	40 1 9/16	700 27 1/2	30 1 3/16	1,5	3	
EW90SUP2	kit with 2 supports for EW60150 for installation parallel to the frets	40 1 9/16	900 35 1/2	30 1 3/16	1,2	2	
EW90SUP3	kit with 3 supports for EW60300 for installation parallel to the frets	40 1 9/16	900 35 1/2	30 1 3/16	1,85	3	
EW120SUP2	kit with 2 supports for EW60150+EW20150INT for installation parallel to the frets	40 1 9/16	1200 47 1/4	30 1 3/16	1,6	2	
EW120SUP3	kit with 3 supports for EW60300+EW20300INT for installation parallel to the frets	40 1 9/16	1200 47 1/4	30 1 3/16	2,4	3	

Screws and joints always included in the single codes.

OVERNET

PERMANENT FALL PROTECTION SYSTEM FOR INDUSTRIAL ROOFING

EN 14963:2007 EN 1873:2006 EN 15057:2006

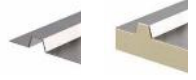

SIMPLE

Supplied in 25-m rolls, it is easily installed outdoors on trapezoidal metal sheet or trapezoidal sandwich panels.

COMPLETE

Complete system composed of: fall protection net, fastening plates, EPDM gaskets and rivets.

STRONG

Strong and durable through the combination of different protective elements: zinc plating, primer and PVC.

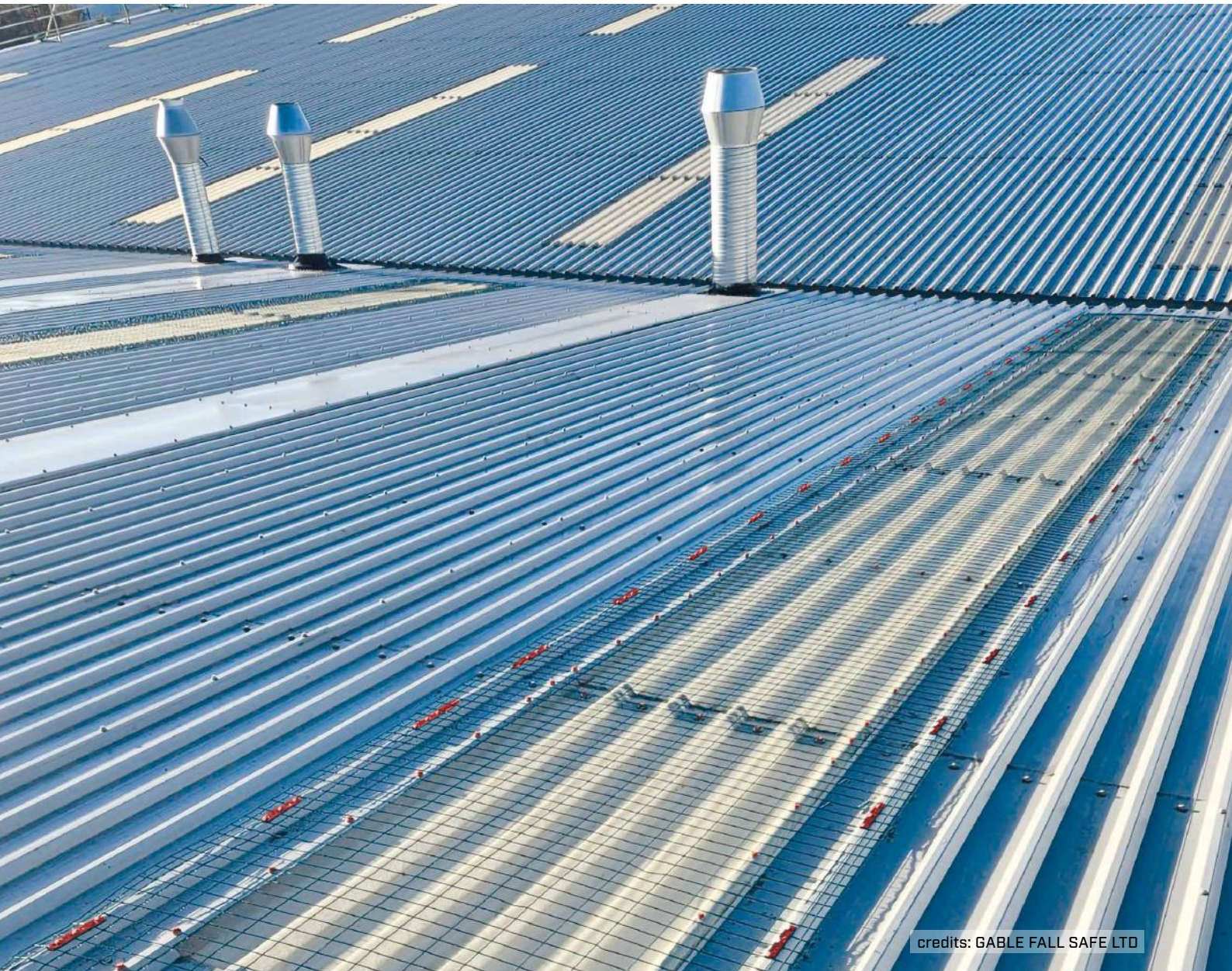

credits: GABLE FALL SAFE LTD

INSTALLATION

INSTALLATION DIAGRAMS

PARALLEL FRETS

Installation scheme D

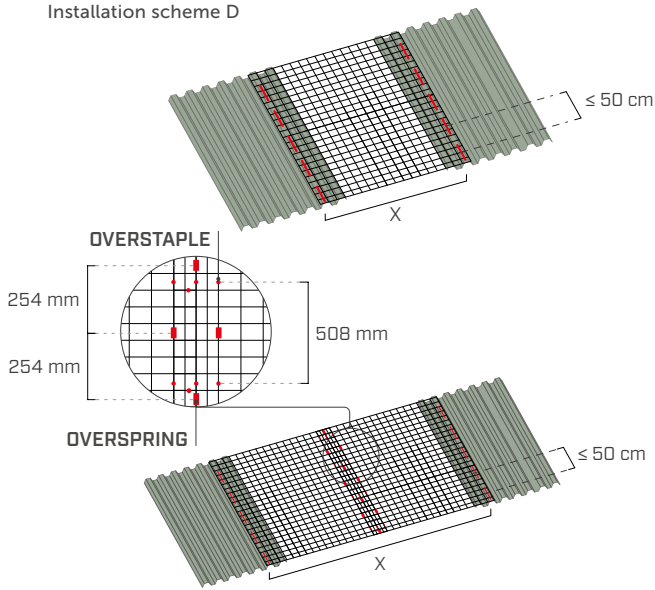

PERPENDICULAR FRETS

Installation scheme E

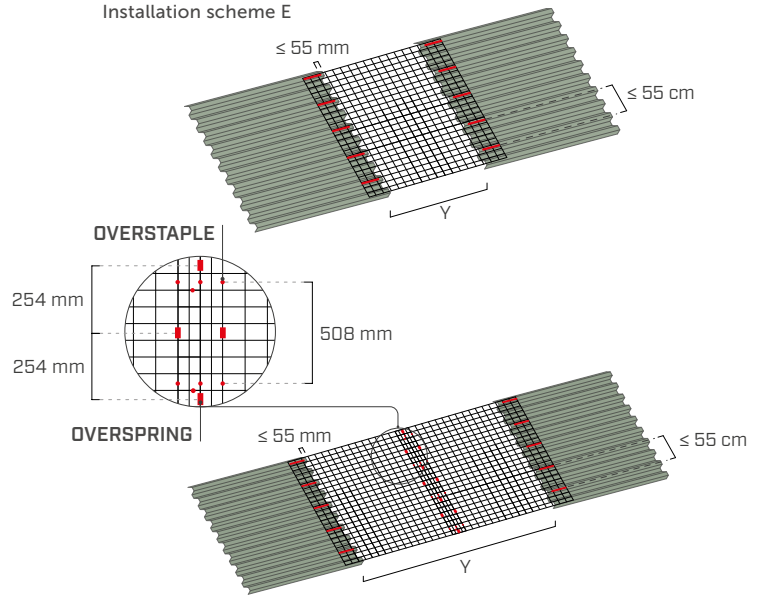







CODE	SINGLE NET		JOINTED NET	
	parallel frets width between last useful frets (X) [mm]	perpendicular frets skylight opening (Y) [mm]	parallel frets width between last useful frets (X) [mm]	perpendicular frets skylight opening (Y) [mm]
OVERNET1020B	≤ 880	≤ 690	-	1500-1610
OVERNET1220B	890-1070	700-890	1600-1780	1620-2010
OVERNET1520B	1080-1390	900-1200	1790-2190	2020-2620
OVERNET1830B	1400-1690	1210-1500	2200-2790	2630-3230
OVERNET2030B	1700-1890	1510-1700	2800-3410	3240-3630
OVERNET2230B	1890 - 2080	1710-1910	3820-4220	3640-4040
OVERNET2440B	2090 - 2300	1920-2110	4260-4630	4050-4450

To make the system certifiable and obtain more detailed information on the various product installations, it is essential to follow the installation instructions outlined in the relevant Technical Approval No. 650 issued by the National Research Council – Construction Technologies Institute (ITC-CNR).

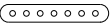
CODES AND DIMENSIONS

CODE	description	colour	B		L		pcs
			[mm]	[in]	[m]	[ft]	
OVERNET1020B	black PVC-coated fall protection safety net	● (black)	1020	40 3/16	25	82 1/4	1
OVERNET1220B			1220	48 1/16	25	82 1/4	1
OVERNET1520B			1520	59 13/16	25	82 1/4	1
OVERNET1830B			1830	72 1/16	25	82 1/4	1
OVERNET2030B			2030	79 15/16	25	82 1/4	1
OVERNET2230B			2230	87 13/16	25	82 1/4	1
OVERNET2440B			2440	96	25	82 1/4	1

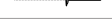
COMPLEMENTARY PRODUCTS

CODE	description	colour	pcs
OVERNETBRAR	red fastening plate for OVERNET (19 x 142 x 2 mm)	●	100 
OVERSPRING	joining spring for net Ø28x37,5 mm		450 
OVERSTAPLE	joining staples for nets 20 mm		1000 
OVERNETEPDM	EPDM gasket for OVERNET (19 x 142 x 4 mm)	-	100 
RIV7728	rivet with EPDM washer Ø7,7x28 mm	-	300 
WREN	pliers with dispenser for OVERSTAPLE joining staples	-	1 

ROLLNET

HORIZONTAL FIXED FALL PROTECTION NET

ADAPTABLE

Available in various sizes, to meet all needs of the construction site.

TRANSPORTATION

Supplied in convenient rolls that facilitate transport and installation.

EXISTING STRUCTURES

It can be installed on existing buildings without having to disassemble the skylights.



▼ *Installation of permanent fall protection safety net for securing a skylight on a roof.*



INSTALLATION



steel angle bracket
30 x 30 x 3 mm



timber batten
40 x 50 mm



steel profile
30 x 3 mm

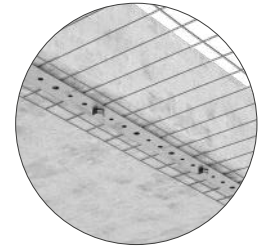

perforated strap
40 x 2 mm

MODEL A



MODEL B



MODEL C



SINGLE NET
distance from the
walking surface ≤ 50 cm

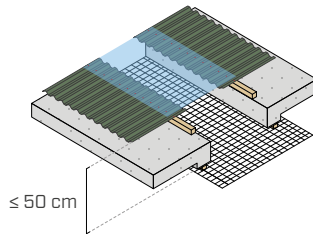

DOUBLE JOINTED NET
distance from the
walking surface ≤ 120 cm

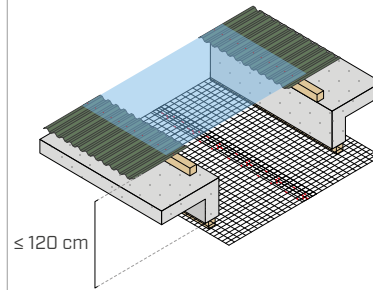

SINGLE NET
distance from the
walking surface 50–120 cm

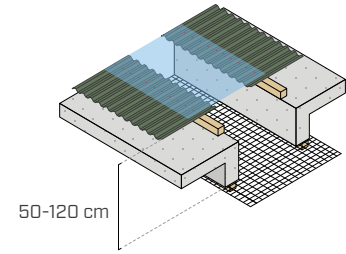

		clear width space	fastener spacing	clear width space	fastener spacing	clear width space	fastener spacing
		[mm]	[mm]	[mm]	[mm]	[mm]	[mm]
MODEL A-C	CODE						
	RONET1020	0-770	1000	1440-1670	254	0-770	254
	RONET1220	730-970	900	1850-2080	254	730-970	254
	RONET1520	930-1270	700	2350-2690	254	930-1270	254
	RONET1830	1230-1580	600	2960-3300	254	1230-1580	254
	RONET2030	1530-1780	500	3460-3710	254	1530-1780	254
	RONET2230	1730-1980	400	3870-4110	254	1730-1980	254
RONET2530	1930-2280	300	4370-4720	254	1930-2280	254	
MODEL B	RONET1020	0-840	1000	1530-1740	254	0-840	254
	RONET1220	820-1040	900	1940-2150	254	820-1040	254
	RONET1520	1020-1340	700	2440-2760	254	1020-1340	254
	RONET1830	1320-1650	600	3060-3370	254	1320-1650	254
	RONET2030	1630-1850	500	3560-3780	254	1630-1850	254
	RONET2230	1830-2050	400	3970-4170	254	1830-2050	254
	RONET2530	2030-2350	300	4470-4790	254	2030-2350	254

To make the system certifiable and obtain more detailed information on the various product installations, it is essential to follow the installation instructions outlined in the relevant Technical Approval No. 650 issued by the National Research Council – Construction Technologies Institute (ITC-CNR).

CODES AND DIMENSIONS

CODE	material	B [mm] [in]	L [m] [ft]	pcs
RONET1020	zinc-plated steel	1020 40 3/16	25 82 1/4	1
RONET1220		1220 48 1/16	25 82 1/4	1
RONET1520		1520 59 13/16	25 82 1/4	1
RONET1830		1830 72 1/16	25 82 1/4	1
RONET2030		2030 79 15/16	25 82 1/4	1
RONET2230		2230 87 13/16	25 82 1/4	1
RONET2530		2530 96	25 82 1/4	1



COMPLEMENTARY PRODUCTS

CODE	description
HBS	screw for timber $\varnothing 6$ mm
SKR	screw anchor for concrete $\varnothing 7.5$ mm
SBS6360	self-drilling timber-to-metal screw $\varnothing 6.3$ mm
SBS6370	
SBS6385	
LBB4030	perforated strap 50 m x 40 mm x 3 mm
LBB4020	perforated strap 50 m x 40 mm x 2 mm
OVERSPRING	joining spring for nets
OVERSTAPLE	joining staples for nets 20 mm
WREN	pliers with dispenser for OVERSTAPLE joining staples

I HORIZONTAL NET

HORIZONTAL POLYPROPYLENE FALL PROTECTION SAFETY NET

EN
1283-1
Tipo S



SAFE

Fastener spacing optimised to 2,5m to ensure product safety and rapid installation.

MODULAR

Possibility of joining several nets together using HORCONNECT sewing rope to cover larger areas.

CAN BE PERSONALIZED

Also available in other colours on request (red, blue, white) and in personalised formats for specific net sizes.

▼ *Installation of temporary polypropylene fall protection nets for securing a timber roof under construction.*



■ FIELDS OF APPLICATION

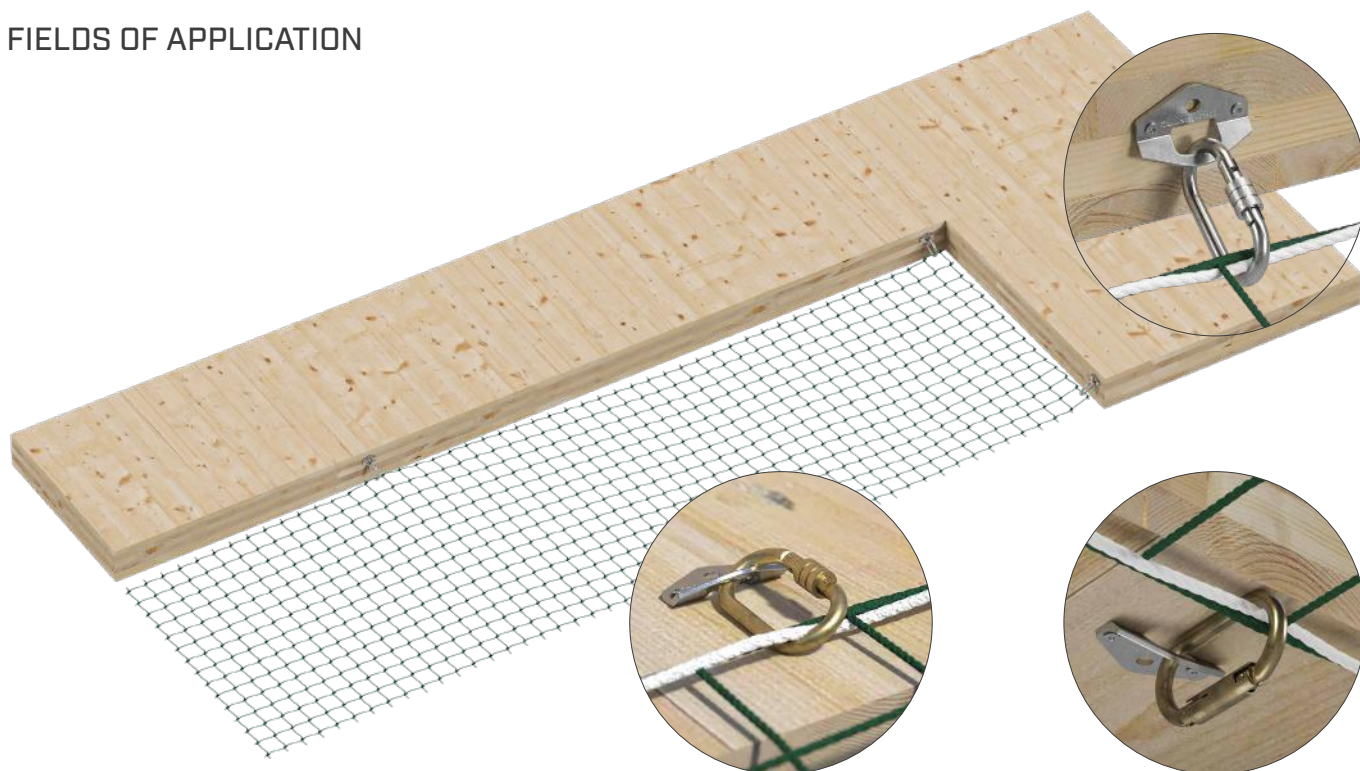

■ CODES AND DIMENSIONS

CODE	B		L		mesh		rope		weight [kg]	pcs
	[m]	[ft]	[m]	[ft]	[mm]	[in]	[mm]	[in]		
HOR510	5	16 4 7/8	10	32 9 3/4	100	4	Ø5	Ø0.2	11,4	1
HOR610	6	19 8 1/4	10	32 9 3/4	100	4	Ø5	Ø0.2	13,7	1
HOR7515	7,5	24 7 1/4	15	49 2 1/2	100	4	Ø5	Ø0.2	25,7	1
HOR1010	10	32 9 3/4	10	32 9 3/4	100	4	Ø5	Ø0.2	22,9	1

COMPLEMENTARY PRODUCTS

CODE	standard	description	dimensions [mm]	weight [g]	<> [kN]	∧ ∨ [kN]	pcs	
HORHOOK(*)	-	base plate for net hooking	52 x 80 x 4	-	-	-	1	
CARSCREW	CE-EN362/B	connector with screwgate	-	160	25	7	1	
CARTWIST	CE-EN362/B	connector with "Twist-Lock" gate	-	173	20	7	1	
HORHOOKC(*)	-	net hook for concrete	M10 x 110	-	-	-	1	
HORHOOKS(*)	-	net hook for steel	M12 x 130	-	-	-	1	
HORFIX	-	fastening cord per linear metre	Ø14	-	-	-	1	
HORCONNECT	-	sewing cord per linear metre	Ø6	-	-	-	1	

FASTENING FOR HORHOOK

substructure	fasteners [mm]	pcs	substructure	fasteners [mm]	pcs	substructure	fasteners [mm]	pcs
timber	HBS Ø6	2	concrete	AB1 / AB7 Ø10	1	steel	EKS M10 + ULS + MUT	1
				SKR-CE Ø10	1			
				VIN-FIX Ø10	1			

(*) Recommended fastening every 2,5 m.

VERTICAL NET

VERTICAL POLYPROPYLENE FALL PROTECTION SAFETY NET

EN
1283-1
Tipo U



SAFE

Protection system for roof edges and scaffolding.

FUNCTIONAL

Installation by inserting each individual link in the scaffold pipe or via fastening straps (optional).



VERSATILE

On request, it is also available in different colours (red, blue, white).

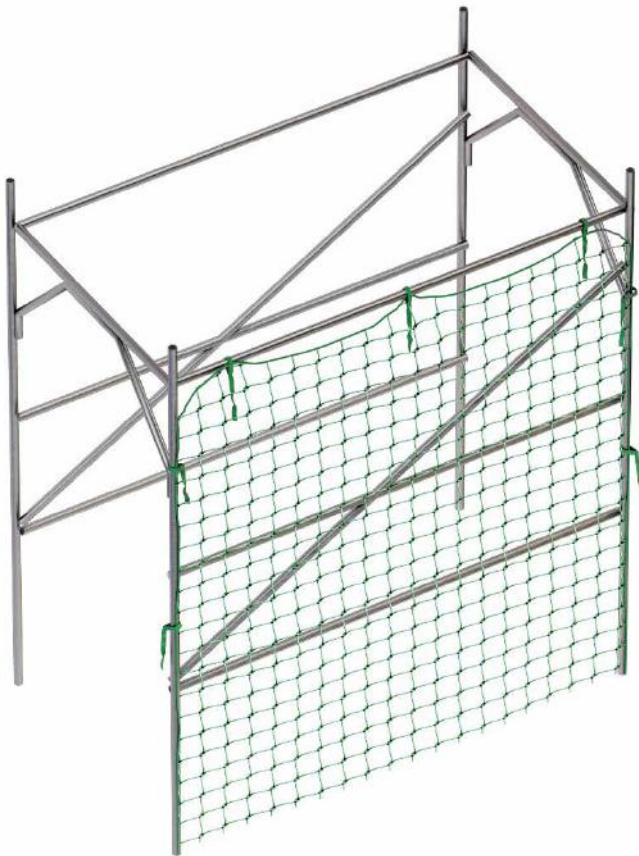

CODES AND DIMENSIONS

CODE	B		L		mesh		rope		weight	pcs
	[m]	[ft]	[m]	[ft]	[mm]	[in]	[mm]	[in]	[kg]	
VER210	2	6' 6 3/4"	10	32' 9 3/4"	100	4	Ø5	Ø0.2	4,5	1

COMPLEMENTARY PRODUCTS

CODE	description	Belt fastening spacing		L		pcs
		[mm]	[in]	[mm]	[in]	
VERBENT	fastening strap for side fall protection safety net	700	27 1/2	600	23 5/8	1

FRAME NET

FALL PROTECTION SAFETY NET WITH FRAME

EN
13374
C



FUNCTIONAL

Possibility of installation on roofs with an inclination of up to 60°.

FAST

Quick and easy assembly thanks to the few modular components.

VERSATILE

Ideal for securing the roof when there is no possibility of installing external scaffolding or perimeter protection with external fastening.



CODES AND DIMENSIONS

CODE	description	weight [kg]	pcs
FRAMENET	net with frame complete with quick straps	11	1
FRAMESUP	support for net with frame	9,2	1
FRAMEHOOK	hook for net with frame	1	1

The distance between the fastening brackets is max. 2.4 m. Each first module of the protection system (near each falling edge) must be fixed with two brackets and two supports, all other modules assembled next to each other and secured with quick fastening straps are fixed with only one support and fastening bracket

TEMPORARY RAILING BARRIERS

EDGE TEMP 1

TEMPORARY RAILING
ROOF SIDE



CODES AND DIMENSIONS*

CODE	standard	material	max. slope of use	max. spacing between supports		minimum thickness of fixture [mm] [in]	substructure	weight [kg]	pcs
				[mm]	[in]				
EDGETEMP1	EN 13374 Class A	zinc-plated steel	used as a lateral protection support, with a maximum slope of 10° from horizontal	1400	55 1/8	from 80 to 192 from 3 1/8 to 7 9/16	 timber beam	8,80	1

* The values indicated are derived from experimental tests carried out under the supervision of third party organisations according to the referenced standard. For a calculation report with minimum distances, according to the referenced normative requirements, the substructure must be verified by a qualified engineer before installation.

EDGE TEMP 2

TEMPORARY RAILING
ROOF FRONT



CODES AND DIMENSIONS*

CODE	standard	material	max. slope of use	max. spacing between supports		minimum thickness of fixture [mm] [in]	substructure	weight [kg]	pcs
				[mm]	[in]				
EDGETEMP2	EN 13374 Class B	zinc-plated steel	maximum roof slope 30°	1400	55 1/8	from 80 to 200 from 3 1/8 to 8	 timber beam	9,00	1

* The values indicated are derived from experimental tests carried out under the supervision of third party organisations according to the referenced standard. For a calculation report with minimum distances, according to the referenced normative requirements, the substructure must be verified by a qualified engineer before installation.

EDGE TEMP 3

TEMPORARY RAILING FOR HORIZONTAL EDGES



CODES AND DIMENSIONS*

CODE	standard	material	max. slope of use	max. spacing between supports		substructure	weight [kg]	pcs
				[mm]	[in]			
EDGETEMP3	EN 13374 Class A	zinc-plated steel	the slope of the working surface (impact sound surface) must be less than 10°	1400	55 1/8	 concrete	4,23	1



* The values indicated are derived from experimental tests carried out under the supervision of third party organisations according to the referenced standard. For a calculation report with minimum distances, according to the referenced normative requirements, the substructure must be verified by a qualified engineer before installation.

EDGE TEMP 4

TEMPORARY UNIVERSAL RAILING WITH STEM



CODES AND DIMENSIONS*

CODE	standard	material	max. slope of use	max. spacing between supports		minimum thickness of fixture [mm]	substructure	weight [kg]	pcs
				[mm]	[in]				
EDGETEMP4	EN 13374 Class A	zinc-plated steel	the slope of the working surface (impact sound surface) must be less than 10°	1400	55 1/8	clamp max. opening 700 clamp max. opening 27 1/2	 timber	5,20	1
							 concrete		
							 steel		

* The values indicated are derived from experimental tests carried out under the supervision of third party organisations according to the referenced standard. For a calculation report with minimum distances, according to the referenced normative requirements, the substructure must be verified by a qualified engineer before installation.

LADDER HOOKS

HANG TEMP

MOBILE LADDER HOOK



CODES AND DIMENSIONS

CODE	material	B [mm] [in]	H [mm] [in]	L [mm] [in]	weight [kg]	pcs
HANGTEMP	aluminium	445 17 1/2	300 11 3/4	1000 39 3/8	2,2	1

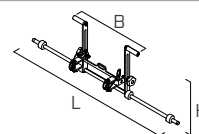

HANG ROOF

LADDER HOOK FOR PITCHED ROOFS

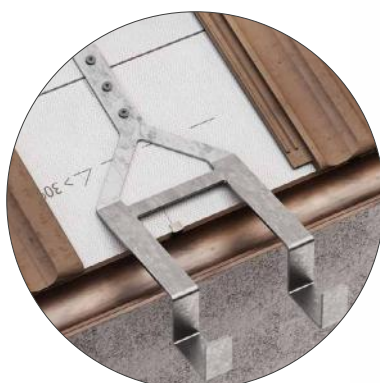

CODES AND DIMENSIONS

CODE	material	B [mm] [in]	H [mm] [in]	L [mm] [in]	weight [kg]	pcs
HANGROOF	zinc-plated steel	280 11	211 8 5/16	640 25 3/16	3,6	1
HANGROOFA2	AISI 304 stainless steel grade 1.4301	280 11	211 8 5/16	640 25 3/16	3,6	1

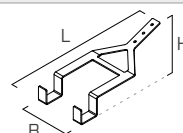

HANG WALL

LADDER HOOK FOR WALL



CODES AND DIMENSIONS

CODE	material	B [mm] [in]	H [mm] [in]	L [mm] [in]	weight [kg]	pcs
HANGWALL	zinc-plated steel	128 5 1/16	196 7 11/16	280 11	3,5	1

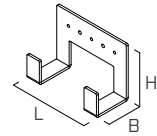

HANG PLAIN

LADDER HOOK FOR FLAT SURFACES



CODES AND DIMENSIONS

CODE	material	B [mm] [in]	H [mm] [in]	L [mm] [in]	weight [kg]	pcs
HANGPLAIN	zinc-plated steel	212 8 3/8	116 4 9/16	280 11	3,5	1

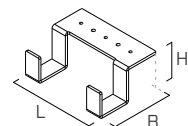

PERSONAL PROTECTIVE EQUIPMENT

PERSONAL PROTECTIVE EQUIPMENT

HELMETS



HERO

page 180 <



POP

page 183 <

HARNESSES



OLYMPIA

page 184 <



SPARTA

page 186 <



HESTIA

page 187 <



MAIA

page 188 <



BIA

page 188 <



METIS

page 189 <



METIS ANSI

page 189 <



IRIS

page 190 <



APATE

page 190 <



PLANK

page 192 <

FALL PROTECTION AND POSITIONING



DOUBLE SICUROPE

page 193 <



SCAFFOLD DUO

page 193 <



SICUROPE

page 193 <



POSITIONING

page 194 <



ENERGY

page 194 <



PLATROPE

page 194 <



LINOSTOP

page 195 <



ROPE 1

page 195 <



ROPE 2

page 195 <



BACK

page 196 <

RETRACTABLE DEVICES



FALL BLOCK

page 197 <



STRAP

page 197 <

KIT



KIT ROOF BASE

page 198 <



KIT ROOF MID

page 198 <



KIT ROOF PRO

page 198 <



KIT SCAFFOLD BASE

page 199 <

						
		BAND23 page 200 ◀	BAND35 page 200 ◀	RIG page 200 ◀	LANSTECO page 201 ◀	
						
CLASSIC page 202 ◀	OVAL page 202 ◀	XXL page 203 ◀	HELICON page 203 ◀	MULTIRING page 204 ◀	FAST LINK page 204 ◀	
						
		ROPE105 page 206 ◀	ROPE11 page 206 ◀	EDGE page 207 ◀	EDGEPRO page 207 ◀	
						
	ROPE BRAKE page 208 ◀	ROPE BRAKE 2 page 208 ◀	ELEVATOR page 209 ◀	BELLY page 209 ◀	FOOT STEP page 209 ◀	
			TRIPODS AND CRANES			
TRI page 210 ◀		DAV page 212 ◀		STRETCHER page 215 ◀	LIFTING HELP page 215 ◀	
						
TOOLGRAB page 216 ◀	EXTEND page 217 ◀	SINGLE - DOUBLE page 217 ◀	GLASS 1 page 218 ◀	GLASS 2 page 218 ◀	HEADPHONE page 218 ◀	
						
RSBAG page 219 ◀	RBBAG page 219 ◀	GLOVE BASE page 220 ◀	GLOVE MID page 220 ◀	GLOVE PRO page 221 ◀	VEST page 222	

TEMPORARY ANCHOR SYSTEMS

CONNECTORS

ROPES AND ACCESSORIES

DESCENDERS AND CLAMPS

RESCUE

ACCESSORIES

HELMETS



HERO

HELMET FOR WORK AT HEIGHT, ON CONSTRUCTION SITES OR IN INDUSTRIAL AREAS

VERSATILE

Available in multiple versions and colours, the HERO helmet complies with the main certifications (EN, ANSI, AS/NZS). Ideal for both work at height and other industrial contexts.

ERGONOMIC

Lightweight, with a sporty design, featuring wheel ratchet size adjustment. Ventilation ensures comfort even on the hottest days. Available in various colours and customisable with your logo.

ACCESSORIES

Designed to meet all needs, the HERO helmet is compatible with accessories such as ear muffs, lights and sun shields, facilitating work in all environments and conditions.

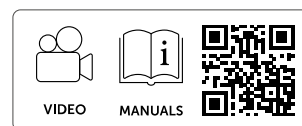

CODES AND CHARACTERISTICS



HERO



HEROW



HEROORA



HERORED



HEROYEL



HEROYELHV



HEROGREEN



HEROBLUE





















HEROBLA

CODE	standard	description	material	weight [g]	colour	size	pcs
HERO	EN 397:2025 Type II	grey colour helmet for working at height	ABS, EPS	450	●	UNI 53 - 63 cm UNI 21" - 24 13/16"	1
HEROW	EN 397:2025 Type II	white colour helmet for working at height	ABS, EPS	450	○	UNI 53 - 63 cm UNI 21" - 24 13/16"	1
HEROORA	EN 397:2025 Type II	orange colour helmet for working at height	ABS, EPS	450	●	UNI 53 - 63 cm UNI 21" - 24 13/16"	1
HERORED	EN 397:2025 Type II	red colour helmet for working at height	ABS, EPS	450	●	UNI 53 - 63 cm UNI 21" - 24 13/16"	1
HEROYEL	EN 397:2025 Type II	yellow colour helmet for working at height	ABS, EPS	450	●	UNI 53 - 63 cm UNI 21" - 24 13/16"	1
HEROYELHV	EN 397:2025 Type II	high-visibility yellow colour helmet for working at height	ABS, EPS	450	●	UNI 53 - 63 cm UNI 21" - 24 13/16"	1
HEROGREEN	EN 397:2025 Type II	green colour helmet for working at height	ABS, EPS	450	●	UNI 53 - 63 cm UNI 21" - 24 13/16"	1
HEROBLUE	EN 397:2025 Type II	blue colour helmet for working at height	ABS, EPS	450	●	UNI 53 - 63 cm UNI 21" - 24 13/16"	1
HEROBLA	EN 397:2025 Type II	black colour helmet for working at height	ABS, EPS	450	●	UNI 53 - 63 cm UNI 21" - 24 13/16"	1
HERODIEL	EN 397:2025 Type II, EN 50365:2023	grey colour dielectric helmet	ABS, EPS	450	●	UNI 53 - 63 cm UNI 21" - 24 13/16"	1
HEROANS	ANSI/ISEA Z89.1-2014 (R2019) Type II, Class C	grey colour helmet for working at height with ANSI certification	ABS, EPS	450	●	UNI 53 - 63 cm UNI 21" - 24 13/16"	1
HEROWANS	ANSI/ISEA Z89.1-2014 (R2019) Type II, Class C	white colour helmet for working at height with ANSI certification	ABS, EPS	450	○	UNI 53 - 63 cm UNI 21" - 24 13/16"	1
HEROASNZ	AS/NZS 1801:2024	grey colour helmet for working at height with AS/NZS certification	ABS, EPS	450	●	UNI 53 - 63 cm UNI 21" - 24 13/16"	1
HEROWASNZ	AS/NZS 1801:2024	white colour helmet for working at height with AS/NZS certification	ABS, EPS	450	○	UNI 53 - 63 cm UNI 21" - 24 13/16"	1

HELMETS

COMPLEMENTARY PRODUCTS

CODE	standard	description	weight [g]	pcs	
HEROEAR31	EN 352-3:2020	set of earmuffs - 31 dB	315	1	
HEROVISWHITE	ISO 16321-1:2021	clear visor	52	1	
HEROVISDARK	ISO 16321-1:2021	smoked visor	52	1	
HEROVISCLIP	-	replacement adapter for visors kit	22	1	
HEROVISCOVER	-	visor protection	67	1	
HEROVISFULL	ISO 16321-1:2021	full-face visor for face protection	133	1	
HEROVISMESH	ISO 16321-3:2021	full-face mesh visor for face protection suitable for arborists	116	1	
HERONEC	-	neck cover	25	1	
HEROHAT	-	full sun protection sombrero	84,5	1	
HEROHOLDER	-	business card holder	3	1	
HEROSTRA397	-	chinstrap for EN 397	42	1	
HEROBRIM	-	front visor for helmets	-	1	
HEROBAG	-	helmet carry bag	52,5	1	
HEROCLIP	-	replacement front clip kit	13	1	
HEROSIDE	-	replacement side adapter kit for mounting ear muffs and visors	5	1	
HEROPAD	-	replacement internal padding kit	20	1	
HEROHVSTICK	-	reflective stickers	7,5	1	
HEROLAMPHEAD	-	front lamp with elastic headband	-	1	

POP



HELMET FOR WORKPLACE SAFETY, ON INDUSTRY AND CONSTRUCTION

- Adjustable chin strap with quick release for safe and easy use
- Internal padding for greater comfort and removable inner part for easy and thorough cleaning
- Rear reflective element for enhanced visibility during night work or low-light conditions
- Rear wheel ratchet size adjustment and top holes for improved ventilation



CODES AND CHARACTERISTICS

CODE	standard	description	material	weight [g]	colour	size	pcs
POP	CE - EN 397	white colour safety helmet	ABS	396	○	UNI 54 - 63 cm UNI 21" - 24' 13/16"	1
POPGREY	CE - EN 397	grey colour safety helmet	ABS	396	●	UNI 54 - 63 cm UNI 21" - 24' 13/16"	1
POPYEL	CE - EN 397	yellow colour safety helmet	ABS	396	●	UNI 54 - 63 cm UNI 21" - 24' 13/16"	1

COMPLEMENTARY PRODUCTS

CODE	standard	description	weight [g]	pcs
HEROEAR31	CE - EN 352-3	set of earmuffs - 31 dB	315	1



HARNESSES

OLYMPIA



FULL PROFESSIONAL HARNESS FOR ROPE ACCESS WORK

- Full work harness with 5 attachment points
- Designed for rope access work, allowing suspension, positioning, restraint and fall arrest
- Excellent lumbar support thanks to the wide ergonomic padding on the belt
- Dorsal attachment that adapts to the back's curvature
- Equipped with 5 gear loops and folding side attachment points with snap mechanism
- Off-centred ventral ascender attachment to avoid interference with other devices

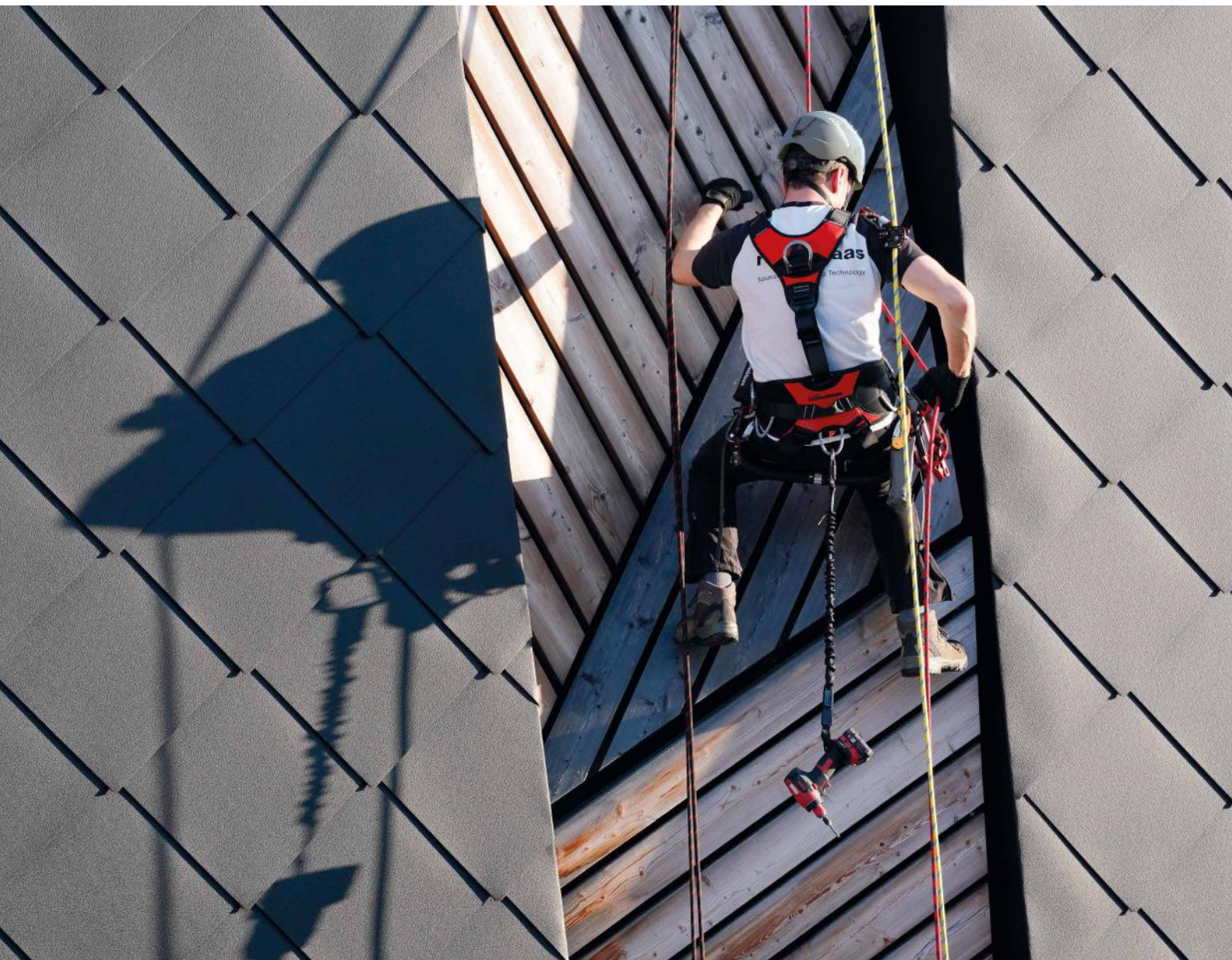
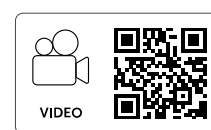



FRONT



REAR



Openable leg loops for easy and quick dressing.



Excellent lumbar support thanks to the wide ergonomic padding on the belt.



CODES AND CHARACTERISTICS

CODE	standard	A [cm] [in]	B [cm] [in]	size	weight [g]	pcs
OLYMPIASM	CE - EN 361 - EN 358 - EN 813	90-115 35 1/2 - 45 1/4	55-65 21 5/8 - 25 9/16	S/M	2280	1
OLYMPIAL	CE - EN 361 - EN 358 - EN 813	100-130 39 3/8 - 51 3/16	60-70 23 5/8 - 27 1/2	L	2330	1

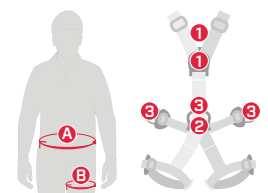

- 1. EN 361 | 15 kN
- 2. EN 358 - EN 813 | 15 kN
- 3. EN 358 | 15 kN

HARNESSES

SPARTA



COMPLETE PROFESSIONAL HARNESS FOR FALL PROTECTION SYSTEMS, POSITIONING, ROPE ACCESS WORK

- Large padding for maximum comfort during use, lightened waistband padding to increase breathability
- Equipped with three anchor points (ventral, sternal and dorsal) and two lateral positioning rings, all in light alloy
- The upper part can be completely disconnected from the lower part for inspection and cleaning purposes
- Two special loops are provided on the shoulder straps to connect the vertical recovery system if required



CODES AND CHARACTERISTICS

CODE	standard	A [cm] [in]	B [cm] [in]	size	weight [g]	pcs
SPARTAS	CE - EN 361 - EN 358 - EN 813 EN 12277/A/C	76/94 29 15/16 - 37	50/60 19 3/4 - 23 5/8	S	1650	1
SPARTAML	CE - EN 361 - EN 358 - EN 813 EN 12277/A/C	84/102 33 1/16 - 40 3/16	58/66 22 13/16 - 26	M/L	1700	1
SPARTAXL	CE - EN 361 - EN 358 - EN 813 EN 12277/A/C	90/126 35 1/2 - 49 5/8	60/74 23 5/8 - 29 1/8	XL	1750	1

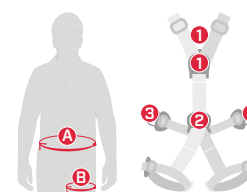

1. EN 361 | 15 kN
2. EN 358 - EN 813 | 15 kN
3. EN 358 | 15 kN

HESTIA



COMPLETE HARNESS FOR FALL PROTECTION SYSTEMS

- Three quick-connect buckles on chest and leg loops for easy and secure wear
- Dorsal section and legs padded to ensure excellent comfort for workers
- Front tool holder at sternum



CODES AND CHARACTERISTICS

CODE	standard	A [cm] [in]	B [cm] [in]	C [cm] [in]	size	weight [g]	pcs
HESTIAS	CE - EN 361	70/90 27 1/2 - 35 1/2	75/110 29 1/2 - 43 5/16	40/60 15 3/4 - 23 5/8	S	1550	1
HESTIAMXL	CE - EN 361	85/100 33 7/16 - 39 3/8	85/120 33 7/16 - 47 1/4	50/75 19 3/4 - 29 1/2	M/XL	1650	1
HESTIAXXL	CE - EN 361	100/130 39 3/8 - 51 3/16	90/140 35 1/2 - 55 1/8	60/85 23 5/8 - 33 7/16	XXL	1750	1

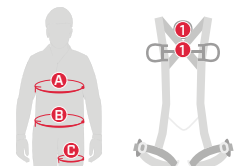

1. EN 361 | 15 kN

HARNESSES

MAIA

COMPLETE PROFESSIONAL HARNESS FOR FALL PROTECTION SYSTEMS, POSITIONING, ROPE ACCESS WORK

- The elastic straps guarantee excellent fit
- Equipped with plastic material holder rings and four tool nodes
- Equipped with three anchor points (ventral, sternal and dorsal) plus lateral positioning rings



CODES AND CHARACTERISTICS

CODE	standard	A [cm] [in]	B [cm] [in]	C [cm] [in]	size	weight [g]	pcs
MAIAS	CE - EN 361 - EN 358 EN 813	80/142 31 1/2 - 55 7/8	42/75 16 9/16 - 29 1/2	-	S	1720	1
MAIAMXL	CE - EN 361 - EN 358 EN 813	-	82/144 32 5/16 - 56 11/16	44/77 17 1/4 - 30 5/16	M/XL	1820	1

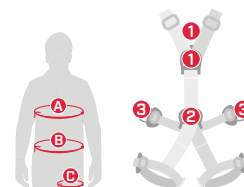

1. EN 361 | 15 kN
2. EN 358 - EN 813 | 15 kN
3. EN 358 | 15 kN

BIA

FULL PROFESSIONAL HARNESS FOR FALL PROTECTION SYSTEMS

- Dorsal attachment point moved up to make wearing easier
- Front attachment point with two large fluorescent yellow rings that facilitate identification
- Gear rings in webbing
- Quick-close pectoral buckle for fast and effective wear
- Easy-to-wear work harness featuring new ergonomic and breathable back padding



CODES AND CHARACTERISTICS

CODE	standard	A [cm] [in]	B [cm] [in]	size	weight [g]	pcs
BIAML	CE - EN 361	72/105 28 3/8 - 41 5/16	50/62 19 3/4 - 24 7/16	M/L	900	1
BIAXL	CE - EN 361	89/130 35 1/16 - 51 3/16	62/80 24 7/16 - 31 1/2	XL	950	1

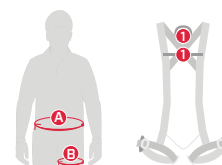

1. EN 361 | 15 kN

METIS



COMPLETE HARNESS FOR FALL PROTECTION SYSTEMS

- Equipped with automatic buckles on the legs for quick fitting
- Back anchor with steel ring and sternal anchor with textile webbing rings
- Equipped with two large material loops located at the sides in a rear position



CODES AND CHARACTERISTICS

CODE	standard	A [cm] [in]	B [cm] [in]	size	weight [g]	pcs
METISML	CE - EN 361	72/105 28 3/8 - 41 5/16	50/62 19 3/4 - 24 7/16	M/L	1170	1
METISXL	CE - EN 361	89/130 35 1/16 - 51 3/16	62/80 24 7/16 - 31 1/2	XL	1220	1

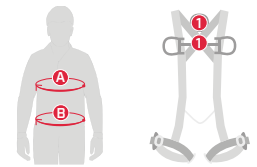

1. EN 361 | 15 kN

METIS ANSI



COMPLETE HARNESS FOR FALL PROTECTION SYSTEMS

- Fall arrest harness for work: light, practical and comfortable
- Equipped with load indicators to warn of falls and therefore the need to replace the product
- Equipped with two large gear loops, positioned on the side and slightly retracted for optimal load management



CODES AND CHARACTERISTICS

CODE	standard	A [cm] [in]	B [cm] [in]	size	weight [g]	pcs
METISANSIML	CE - EN 361 - ANSI/ASSE Z359.11-2014	72/105 28 3/8 - 41 5/16	50/62 19 3/4 - 24 7/16	M/L	1090	1
METISANSIXL	CE - EN 361 - ANSI/ASSE Z359.11-2014	89/130 35 1/16 - 51 3/16	62/80 24 7/16 - 31 1/2	XL	1130	1

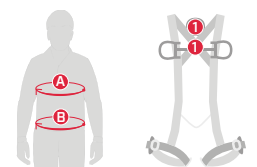

1. EN 361 | 15 kN

HARNESSES

IRIS



HARNESS FOR FALL PROTECTION SYSTEMS

- Lightweight, ergonomic work harness
- Back anchor with steel ring and sternal anchor with textile webbing rings
- Simple and light design and materials made it ideal for short-term uses



CODES AND CHARACTERISTICS

CODE	standard	size	weight [g]	pcs
IRIS	CE - EN 361	UNI	710	1

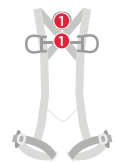

1. EN 361 | 15 kN

APATE



COMPLETE HARNESS FOR FALL PROTECTION AND POSITIONING SYSTEMS

- Sternal and dorsal attachment points plus lateral positioning rings
- Wide waist belt guarantees good lumbar support
- The buckles ensure fast and easy adjustment







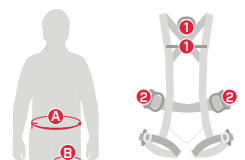



CODES AND CHARACTERISTICS











CODE	standard	A [cm] [in]	B [cm] [in]	size	weight [g]	pcs
APATEMXL	CE - EN 361 - EN 358	85/100 33 7/16 - 39 3/8	85/120 33 7/16 - 47 1/4	M/XL	1160	1



1. EN 361 | 15 kN
2. EN 358 | 15 kN

HARNESSES | comparison

	HARNESSES			
				
	OLYMPIA	SPARTA	HESTIA	MAIA
CE	●	●	●	●
ANSI	-	-	-	-
ERC	-	-	-	-
	●	●	●	●
	●	●	-	●
	●	●	-	●
standard	EN 361 / EN 358 EN 813	EN 361 / EN 358 EN 813 / EN 12277/A/C	EN 361	EN 361 / EN 358 EN 813
	150	150	140	140
	2280-2330	1650-1750	1550-1750	1720-1820

	HARNESSES				
					
	BIA	METIS ANSI	METIS	IRIS	APATE
CE	●	●	●	●	●
ANSI	-	●	-	-	-
ERC	-	-	●	-	-
	●	●	●	●	●
	-	-	-	-	●
	-	-	-	-	-
standard	EN 361	EN 361 / ANSI Z359.11-2014	EN 361	EN 361	EN 361 EN 358
	150	140	140	-	-
	900-950	1090-1130	1170-1220	710	1160

HARNESSES

PLANK

SEAT FOR EXTENDED SUSPENSION WORK

- Innovative seat design for prolonged suspension
- The aluminium frame can be removed, ensuring maximum lightness and compact dimensions for easy transport
- The seat, made of interwoven belts, adjusts perfectly to the body; this provides incredible ergonomics
- Once disassembled and placed in its bag, PLANK takes up a surprisingly small amount of space
- Perfect for use in combination with the OLYMPIA harness with RIG3 anchor multiplier and HELICON connector

CODES AND CHARACTERISTICS

CODE	material	weight [g]	pcs
PLANK	aluminium / polyester	890	1



FALL PROTECTION AND POSITIONING

DOUBLE SICUROPE

CE

DOUBLE ARM ROPE WITH ENERGY ABSORBER

- Complete with steel carabiner with screw ring nut and two aluminium connectors with double safety catch
- Energy absorber with activation indicator
- Protective fabric holder for energy absorber with Velcro closure

CODES AND CHARACTERISTICS

CODE	standard	L		weight [g]	pcs
		[m]	[ft]		
DSIC15	CE - EN 355	1,5	4' 11"	890	1
DSIC2	CE - EN 355	2	6' 6 3/4"	930	1



SCAFFOLD DUO

CE

DOUBLE ARM ROPE WITH ENERGY ABSORBER

- Complete with steel carabiner with screw ring nut and two aluminium large aperture (56 mm) connectors with double safety catch included
- Energy absorber with activation indicator
- Protective fabric holder for energy absorber with Velcro closure

CODES AND CHARACTERISTICS

CODE	standard	L		weight [g]	pcs
		[m]	[ft]		
SCA15	CE - EN 355	1,5	4' 11"	1540	1



SICUROPE

CE

SINGLE ARM ROPE WITH ENERGY ABSORBER

- Complete with steel carabiners with screw ring nut
- Protective fabric holder for energy absorber with Velcro closure
- Energy absorber with activation indicator

CODES AND CHARACTERISTICS

CODE	standard	L		weight [g]	pcs
		[m]	[ft]		
SIC15	CE - EN 355	1,5	4' 11"	715	1
SIC2	CE - EN 355	2	6' 6 3/4"	755	1



FALL PROTECTION AND POSITIONING

POSITIONING

ADJUSTABLE POSITIONING LANYARD

- Complete with steel carabiner with screw ring nut and one aluminium connector with double safety catch included
- Progressive length adjustment device for better work positioning
- Tested in accordance with EN 358 for use up to 150kg

CODES AND CHARACTERISTICS

CODE	standard	L		weight [g]	rope diameter		pcs
		[m]	[ft]		[mm]	[in]	
POS2	CE - EN 358 ANSI Z359.3	2	6' 6 3/4"	475	Ø10	Ø0.39	1
POS3		3	9' 10 1/8"	555	Ø10	Ø0.39	1
POS4		4	13' 1 1/2"	635	Ø10	Ø0.39	1



ENERGY

ADJUSTABLE ROPE WITH ENERGY ABSORBER

- Ø12 rope; one end has a knot to adjust the length, the other is sewn with an attachment knot
- Steel carabiner with screw ring nut and second steel large aperture (50 mm) carabiner with double safety catch

CODES AND CHARACTERISTICS

CODE	standard	L		rope diameter		pcs
		[m]	[ft]	[mm]	[in]	
ENERGY	CE - EN 355	2	6' 6 3/4"	Ø12	Ø0.47	1



PLATROPE

ADJUSTABLE ROPE WITH ENERGY ABSORBER FOR PLATFORMS

- Complete with an autoblock steel carabiner and a large opening (56 mm) aluminium connector with double safety catch included
- Provided with BACK device that follows the worker both when ascending and descending, stopping any falls
- Protective case for energy absorber made of fabric with Velcro closure

CODES AND CHARACTERISTICS

CODE	standard	L		weight [g]	rope diameter		pcs
		[m]	[ft]		[mm]	[in]	
PLATROPE	CE - EN 355 EN 353-2	1,9	6' 2 3/4"	1430	Ø11	Ø0.43	1



I LINOSTOP

CE

GUIDED TYPE FALL ARRESTER WITH FLEXIBLE ANCHOR LINE

- Complete with two steel carabiners with screw ring nut
- Guided and sliding-type fall protection device, with fixed installation on the rope

CODES AND DIMENSIONS

CODE	standard	rope		L		weight [g]	pcs
		[mm]	[in]	[m]	[ft]		
LINO10	CE - EN 353-2	Ø12	Ø0.47	10	32' 9 3/4"	2000	1
LINO15	CE - EN 353-2	Ø12	Ø0.47	15	49' 2 1/2"	2500	1
LINO20	CE - EN 353-2	Ø12	Ø0.47	20	65' 7 3/8"	3000	1



I ROPE 1

CE

SEMI-STATIC ROPE WITH SEWN ENDS AND AUTOMATIC CARABINER

- Complete with compact and ergonomic ends with rubber protectors
- Device suitable for use in combination with BACK guided type fall arrester

CODES AND DIMENSIONS

CODE	standard	rope		L		weight [g]	pcs
		[mm]	[in]	[m]	[ft]		
ROPE110	CE - EN 354	Ø11	Ø0.43	10	32' 9 3/4"	820	1
ROPE115	CE - EN 354	Ø11	Ø0.43	15	49' 2 1/2"	1200	1
ROPE120	CE - EN 354	Ø11	Ø0.43	20	65' 7 3/8"	1580	1
ROPE130	CE - EN 354	Ø11	Ø0.43	30	98' 5 1/8"	2340	1
ROPE150	CE - EN 354	Ø11	Ø0.43	50	164' 1/2"	3860	1



I ROPE 2

CE

SPLICED ROPE

- Complete with compact and ergonomic ends with rubber protections
- Equipped with rope protection sheath

CODES AND DIMENSIONS

CODE	standard	rope		L		weight [g]	pcs
		[mm]	[in]	[m]	[ft]		
ROPE21	CE - EN 354	Ø11	Ø0.43	1	3' 3 3/8"	135	1
ROPE215	CE - EN 354	Ø11	Ø0.43	1,5	4' 11"	172	1
ROPE22	CE - EN 354	Ø11	Ø0.43	2	6' 6 3/4"	210	1



FALL PROTECTION AND POSITIONING

BACK

FALL ARRESTER

- Safe and easy to operate with one hand
- It follows the operator optimally both uphill and downhill, stopping any falls
- By pressing the button, it can also be used as a positioner or normal locking device as the device only slides upwards



CODES AND DIMENSIONS

CODE	standard	weight	rope diameter		pcs
		[g]	[mm]	[in]	
BACK	CE - EN 353-2 - EN 12841 A/B - EN 567 ANSI/ASSE Z359.15-2014	420	Ø10/Ø12	Ø0.39/Ø0.47	1

Also available in the EAC version.

RETRACTABLE DEVICES

FALL BLOCK



RETRACTABLE DEVICE WITH STEEL CABLE

- Equipped with ultra-resistant ABS shell, spliced metal cable with reel and double safety lever connector with twist-proof swivel
- The 10 m version is suitable for both horizontal and vertical use
- The 15 and 20 m versions comply with CE EN 360 and ATEX II 2 G c T6 standards for the regulation of equipment intended for use in potentially explosive atmospheres



FALL15 - FALL20



FALL10

CODES AND DIMENSIONS

CODE	standard	L		weight [kg]	pcs
		[m]	[ft]		
FALL10	CE - EN 360	10	32' 9 3/4"	4,6	1
FALL15	CE - EN 360 - ATEX II 2 G c T6	15	49' 2 1/2"	7,2	1
FALL20	CE - EN 360 - ATEX II 2 G c T6	20	65' 7 3/8"	7,7	1

STRAP



RETRACTABLE DEVICE

- External energy absorber with protective cover that can be opened for inspection
- Equipped with swivel top anchor point and twist-lock connector with twist-proof swivel
- Suitable for both vertical and horizontal configurations
- STRAP2 version is also suitable for drop factor 2



STRAP2



STRAP6

CODES AND DIMENSIONS

CODE	standard	L		weight [kg]	pcs
		[m]	[ft]		
STRAP2	CE - EN 360	2	6' 6 3/4"	0,9	1
STRAP6	CE - EN 360	6	19' 8 1/4"	2,4	1

KIT

KIT ROOF BASE

BASE KIT FOR WORKING ON ROOF



FAST LINK



LINOSTOP



POP



IRIS



RSBAG

CODE			page	pcs
KITROOFBASE	FASTD	fast link in carbon steel, half-round "D" shape	204	1
	LINO10	guided type fall arrester with flexible anchor line	195	1
	POP	helmet for workplace safety, on industry and construction	183	1
	IRIS	complete harness for fall protection systems	190	1
	RSBAG	waterproof bag	219	1

KIT ROOF MID

INTERMEDIATE KIT FOR WORKING ON ROOF



FAST LINK



DOUBLE SICUROPE



LINOSTOP



METIS



RSBAG

CODE			page	pcs
KITROOFMID	FASTD	fast link in carbon steel, half-round "D" shape	204	1
	DSIC2	double arm rope with energy absorber	193	1
	LINO10	guided type fall arrester with flexible anchor line	195	1
	METISML	complete professional harness for fall protection systems	189	1
	RSBAG	waterproof bag	219	1

KIT ROOF PRO

PROFESSIONAL KIT FOR WORKING ON ROOF



BACK



ROPE1



SPARTA



RSBAG

CODE			page	pcs
KITROOFPRO	BACK	fall arrester and positioning device	196	1
	ROPE115	semi-static rope with sewn eyelets and self-locking carabiner	195	1
	SPARTAML	complete professional harness for fall protection systems, positioning, rope access work	186	1
	RSBAG	waterproof bag	219	1

KIT SCAFFOLD BASE

BASE KIT FOR WORKING ON SCAFFOLDING



FAST LINK

ENERGY

POP

IRIS

RSBAG

CODE			page	pcs
KITSCAFFBASE	FASTD	fast link in carbon steel, half-round "D" shape	204	1
	ENERGY	adjustable rope with energy absorber	194	1
	POP	helmet for workplace safety, on industry and construction	183	1
	IRIS	complete harness for fall protection systems	190	1
	RSBAG	waterproof bag	219	1

Put yourself on display, not at risk

Showcase safety with our practical and functional display, designed to organise and highlight essential products for protecting those who work at height.



Ask your trusted agent for a copy

rothoblaas.com/safe



rothoblaas

Solutions for Safety

TEMPORARY ANCHOR SYSTEMS

BAND23

RING WEBBING LOAD 23 kN

EAC CE

CODES AND DIMENSIONS

CODE	standard	L		weight [g]	Q _r [kN]	colour	pcs
		[m]	[ft]				
BAND2340	CE - EN 795/B EN 354 - EN 566	0,4	1' 3 3/4"	28	23	●	1
BAND2360	CE - EN 795/B EN 354 - EN 566	0,6	1' 11 5/8"	45	23	●	1
BAND2380	CE - EN 795/B EN 354 - EN 566	0,8	2' 7 1/2"	60	23	● ●	1
BAND23120	CE - EN 795/B EN 354 - EN 566	1,2	3' 11 1/4"	90	23	● ●	1
BAND23180	CE - EN 795/B EN 354 - EN 566	1,8	5' 10 7/8"	135	23	●	1



BAND35

RING WEBBING LOAD 35 kN

EAC CE

CODES AND DIMENSIONS

CODE	standard	L		weight [g]	Q _r [kN]	colour	pcs
		[m]	[ft]				
BAND3530		0,3	1'	52	35	●	1
BAND3560		0,6	1' 11 5/8"	95	35	●	1
BAND3580	CE - EN 795/B - EN 354 ANSI/ASSE Z359.18	0,8	2' 7 1/2"	130	35	●	1
BAND35120		1,2	3' 11 1/4"	185	35	●	1
BAND35150		1,5	4' 11"	230	35	●	1
BAND35180		1,8	5' 10 7/8"	270	35	●	1



RIG

ANCHOR MULTIPLIER

EAC CE

- Anchor multiplier designed to organise a work space and create an easy-to-use system of multiple anchors
- Made of light aluminium alloy

CODES AND DIMENSIONS

CODE	standard	material	n° anchor system	∇ [kN]	pcs
RIG3	CE UIAA 130 V1	aluminium alloy	3	36	1
RIG4	CE UIAA 130 V1	aluminium alloy	4	36	1

Also available in the EAC version



RIG3



RIG4

LANYARD WITH STEEL CABLE CORE

- Fixed length lanyard made of 6 mm diameter (133 strands) galvanised cut-resistant steel cable covered with double polyester braid with an external diameter of 12 mm
- The double braid prevents the cable from sliding along the surface



CODES AND DIMENSIONS

CODE	standard	L		weight [g]	Q _r [kN]	pcs
		[m]	[ft]			
LANSTECO100	CE - EN 795/B - EN 354	1	3' 3 3/8"	295	25	1
LANSTECO160	CE - EN 795/B - EN 354	1,6	5' 3"	440	25	1
LANSTECO200	CE - EN 795/B - EN 354	2	6' 6 3/4"	540	25	1

CONNECTORS

RISE AUTOMATIC LOCKING GATE



two-step opening

RISE LOCK

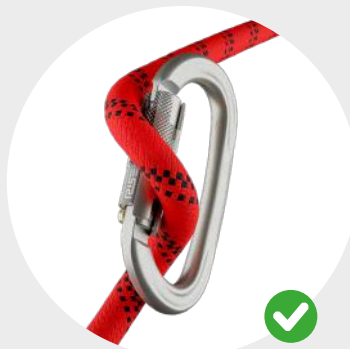

significantly reduces the risk of accidental opening

TWIST LOCK



CLASSIC



OVAL CONNECTOR

- Oval connector available in aluminium and carbon steel, with a circular body that makes it ideal for use with mobile devices (pulleys, clamps, fall protection, etc.)
- Equipped with screw ring nut

CODES AND DIMENSIONS

CODE	standard	weight	<>	∧	⌒	pcs
		[g]	[kN]	[kN]	[kN]	
CLASTE	CE - EN 362/B	176	24	7	6	1
CLAALU	CE - EN 362/B - EN 12275/B - EAC	65	22	7	7	1



CLASTE



CLAALU

OVAL



CONNECTOR FOR CONNECTION TO FIXED POINTS

- Oval-shaped wide-opening connector, ideal for severe conditions and for connection to structural anchor points, lifelines, etc.
- ANSI certified high load connector
- Includes autoblock system

CODES AND DIMENSIONS

CODE	standard	weight	<>	∧	pcs
		[g]	[kN]	[kN]	
OVALSTE	CE - EN 362/M	215	40	15	1
OVALALU	CE - EN 362/B - EN 12275/B - EAC	76	26	9	1
OVALANS	CE - EN 362/M - ANSI Z359.12	220	40	20	1
OVALA4	CE - EN 362/B	230	27	7	1
OVALRISE	CE - EN 362/M	220	40	15	1



OVALSTE



OVALALU



OVALANS



OVALA4



OVALRISE

XXL



CONNECTOR WITH HIGH BREAKING LOAD

- Connector with wide opening and high breaking load. The "D" shape prevents the connector from rotating and allows the load to be distributed along the major axis

CODES AND DIMENSIONS

CODE	standard	weight [g]	<> [kN]	∧ [kN]	pcs
XXLSTE	CE - EN 362/M	260	50	15	1
XXLALU	CE - EN 362/B - EN 12275/B	95	30	15	1
XXLANS	CE - EN 362/M - ANSI Z359.12	273	50	20	1
XXLA4	CE - EN 362/B	250	35	7	1
XXLRISE	CE - EN 362/B	260	50	15	1



XXLSTE

XXLALU

XXLANS



XXLA4

XXLRISE

HELICON



HELICAL CONNECTOR WITH TWISTED BODY

- Special helical connector with twisted steel body
- Allows any device (descenders, ascenders, fall arrest devices, etc.) to be rotated by 90°, optimising its operating condition
- Auto Block locking ring (3 movements) available in both CE and ANSI versions

CODES AND DIMENSIONS

CODE	standard	weight [g]	<> [kN]	∧ [kN]	🔒 [kN]	pcs
HELICON	CE - EN 362/M	215	40	15	13	1
HELICONANSI	CE-EN 362/M ANSI Z359.12	230	40	15	13	1
HELICONALU	CE - EN 362/B EN 12275/B	80	24	8	7	1



HELICON



HELICONANSI



HELICONALU

CONNECTORS

MULTIRING



MULTIDIRECTIONAL OPENABLE RING

- Multidirectional openable ring, ideal for semi-permanent equipment connections
- Allows the simultaneous fastening of more than two devices, with even distribution of the load
- Wide 15 mm opening, designed to facilitate the insertion of spliced ropes
- Easy to disassemble without the need for specific or complex tools



CODES AND DIMENSIONS

CODE	standard	diameter [mm]	weight [g]	<> [kN]	pcs
MULTIRING	EN 362/M	48	75	24	1

FAST LINK



FAST LINKS

- Fast link in carbon steel, half-round "D" shape ①
- Oval fast link, available in stainless steel ②
- Trapezoidal fast link, available in stainless steel ③
- Oval fast link with large stainless steel opening ④



① FASTD



② FASTOVA



③ FASTTRI



















④ FASTOVAL

CODES AND DIMENSIONS

CODE	standard	weight [g]	<> [kN]	^ v [kN]	pcs
FASTD	CE - EN 362/Q - EN 12275/Q - EAC	152	50	15	1
FASTOVA	CE - EN 362/Q - EN 12275/Q - UIAA - EAC	79	40	20	1
FASTOVA2	CE - EN 362/Q - EN 12275/Q - UIAA - EAC	142	60	20	1
FASTTRI	CE - EN 362/Q - EN 12275/Q - UIAA	80	40	10	1
FASTTRI2	CE - EN 362/Q - EN 12275/Q - UIAA	155	60	30	1
FASTOVAL	-	160	-	-	1
FASTOVAL2	-	260	-	-	1

CONNECTORS | comparison

	CLASSIC		OVAL					MULTIRING
								
	CLASTE	CLAALU	OVALSTE	OVALALU	OVALANS	OVALA4	OVALRISE	MULTIRING
CE	●	●	●	●	●	●	●	●
ANSI	-	-	-	-	●	-	-	-
standard	EN 362/B	EN 362/B / EN 12275/B	EN 362/M	EN 362/B / EN 12275/B	EN 362/M / ANSI Z359.12	EN 362/B	EN 362/M	EN 362/M
	screw ring nut	screw ring nut	autoblock	autoblock	autoblock	autoblock	RISE LOCK	-
material	steel	aluminium	steel	aluminium	steel	stainless steel	steel	aluminium
	176	65	215	76	220	230	220	75
	24	20	40	26	40	27	40	24
	7	7	15	9	20	7	15	-
	6	7	-	-	-	-	-	-

	XXL					HELICON		
								
	XXLSTE	XXLALU	XXLANS	XXLA4	XXLRISE	HELICON	HELICON ANSI	HELICONALU
CE	●	●	●	●	●	●	●	●
ANSI	-	-	●	-	-	-	●	-
standard	EN 362/B	EN 362/B / EN 12275/B	EN 362/M / ANSI Z359.12	EN 362/B	EN 362/B	EN 362/B	EN 362/M / ANSI Z359.12	CE - EN 362/B / EN 12275/B
	autoblock	autoblock	autoblock	autoblock	RISE LOCK	autoblock	autoblock	autoblock
material	steel	aluminium	steel	stainless steel	steel	steel	steel	aluminium
	260	95	273	250	260	215	230	80
	50	30	50	35	50	40	40	24
	15	15	20	7	15	15	15	8
	-	-	-	-	-	13	13	7

ROPES AND ACCESSORIES

ROPE105

STATIC THERMOTREATED POLYAMIDE ROPE WITH OUTER SHEATH Ø10.5 mm

- Static rope with a smooth sheath structure for improved abrasion resistance, easy use and good handling



CODES AND DIMENSIONS

CODE	standard	L [m]	material	colour	weight [g/m]	strength [kN]	number of falls	elongation [%]	L [ft]	knottability
ROPE10560W	CE - EN 1891	60	PA	○	65,8	32	14	3,4	196' 10 1/4"	0,7
ROPE10570W	CE - EN 1891	70	PA	○	65,8	32	14	3,4	229' 7 7/8"	0,7
ROPE10580W	CE - EN 1891	80	PA	○	65,8	32	14	3,4	262' 5 5/8"	0,7
ROPE10590W	CE - EN 1891	90	PA	○	65,8	32	14	3,4	295' 3 1/4"	0,7
ROPE105100W	CE - EN 1891	100	PA	○	65,8	32	14	3,4	328' 1"	0,7
ROPE10560B	CE - EN 1891	60	PA	●	65,8	32	14	3,4	196' 10 1/4"	0,7
ROPE10570B	CE - EN 1891	70	PA	●	65,8	32	14	3,4	229' 7 7/8"	0,7
ROPE10580B	CE - EN 1891	80	PA	●	65,8	32	14	3,4	262' 5 5/8"	0,7
ROPE10590B	CE - EN 1891	90	PA	●	65,8	32	14	3,4	295' 3 1/4"	0,7
ROPE105100B	CE - EN 1891	100	PA	●	65,8	32	14	3,4	328' 1"	0,7
ROPE10560R	CE - EN 1891	60	PA	●	65,8	32	14	3,4	196' 10 1/4"	0,7
ROPE10570R	CE - EN 1891	70	PA	●	65,8	32	14	3,4	229' 7 7/8"	0,7
ROPE10580R	CE - EN 1891	80	PA	●	65,8	32	14	3,4	262' 5 5/8"	0,7
ROPE10590R	CE - EN 1891	90	PA	●	65,8	32	14	3,4	295' 3 1/4"	0,7
ROPE105100R	CE - EN 1891	100	PA	●	65,8	32	14	3,4	328' 1"	0,7

ROPE11

STATIC THERMOTREATED POLYAMIDE ROPE WITH OUTER SHEATH Ø11 mm

- Static rope with a smooth sheath structure for improved abrasion resistance, easy use and good handling



CODES AND DIMENSIONS

CODE	standard	L [m]	material	colour	weight [g/m]	strength [kN]	number of falls	elongation [%]	L [ft]	knottability
ROPE1160W	CE - EN 1891	60	PA	○	77,9	37	24	3.1	196' 10 1/4"	0,7
ROPE1170W	CE - EN 1891	70	PA	○	77,9	37	24	3.1	229' 7 7/8"	0,7
ROPE1180W	CE - EN 1891	80	PA	○	77,9	37	24	3.1	262' 5 5/8"	0,7
ROPE1190W	CE - EN 1891	90	PA	○	77,9	37	24	3.1	295' 3 1/4"	0,7
ROPE11100W	CE - EN 1891	100	PA	○	77,9	37	24	3.1	328' 1"	0,7
ROPE1160B	CE - EN 1891	60	PA	●	77,9	37	24	3.1	196' 10 1/4"	0,7
ROPE1170B	CE - EN 1891	70	PA	●	77,9	37	24	3.1	229' 7 7/8"	0,7
ROPE1180B	CE - EN 1891	80	PA	●	77,9	37	24	3.1	262' 5 5/8"	0,7
ROPE1190B	CE - EN 1891	90	PA	●	77,9	37	24	3.1	295' 3 1/4"	0,7
ROPE11100B	CE - EN 1891	100	PA	●	77,9	37	24	3.1	328' 1"	0,7
ROPE1160R	CE - EN 1891	60	PA	●	77,9	37	24	3.1	196' 10 1/4"	0,7
ROPE1170R	CE - EN 1891	70	PA	●	77,9	37	24	3.1	229' 7 7/8"	0,7
ROPE1180R	CE - EN 1891	80	PA	●	77,9	37	24	3.1	262' 5 5/8"	0,7
ROPE1190R	CE - EN 1891	90	PA	●	77,9	37	24	3.1	295' 3 1/4"	0,7
ROPE11100R	CE - EN 1891	100	PA	●	77,9	37	24	3.1	328' 1"	0,7

EDGE

ROPE PROTECTION

- Provided with a ring at the end that allows it to be fastened to a fixed point to keep it in position
- Suitable at any point on the rope thanks to the Velcro closure
- Made of cordura, for greater strength and reduced weight



CODES AND DIMENSIONS

CODE	material	L		weight [g]	pcs
		[mm]	[in]		
EDGE	cordura	700	27 1/2	95	1

EDGEPRO

LIGHT ALUMINIUM ALLOY ROLLER FOR ROPE MOVEMENT

- Made of aluminium alloy for optimal weight
- Modular device with 5 articulated elements allowing adaptation to all types of terrain
- Provided with double nylon rollers that allow two ropes to move independently, even in different directions

CODES AND DIMENSIONS

CODE	material	weight [g]	pcs



DESCENDERS AND CLAMPS

ROPE BRAKE

CE

DESCENDER

- Simple easy to manoeuvre activation catch that guarantees more fluid and precise operation
- Allows two people to be lowered simultaneously for rescue operations
- Allows the cord to be recovered for ascent
- Use with Ø10-12 mm rope max. load 100 kg
- Use with Ø11-12 mm rope max. load 200 kg



CODES AND DIMENSIONS

CODE	standard	weight	rope diameter		pcs
		[g]	[mm]	[in]	
ROPBRA	CE - EN 341 - EN 12841/C	480	Ø10/Ø12	Ø0.39-Ø0.47	1

Also available in the EAC version.

ROPE BRAKE 2

CE

DESCENDERS FOR RESCUE WITH CONNECTORS

- Maximum capacity: 200 kg
- Steel carabiners with screw ring nut included
- Practical bag for transport included
- Evacuation and rescue device that is used together with individual fall protection equipment
- Appropriate for rescue operations in the case of injured or unconscious workers



CODES AND DIMENSIONS

CODE	standard	L		rope diameter		pcs
		[m]	[ft]	[mm]	[in]	
ROPBRA2	CE - EN 341/D	20	65' 7 3/8"	Ø11	Ø0.43	1

ELEVATOR



MOVEABLE ROPE LOCK FOR ASCENT

- Excellent wear resistance and increased strength thanks to a new thermal and chemical treatment applied to the material
- Excellent locking ability even on rope that are particularly muddy thanks to the evacuation grooves in the cam and on the side
- Ergonomic click opening mechanism, easy to operate and protected against impact and accidental opening

CODES AND DIMENSIONS

CODE	standard	weight [g]	version	rope diameter [mm]	pcs
ELERIG	CE - EN 567 - EN 12841/B	225	for right-handed people	Ø8/Ø13 Ø0.31-Ø0.51	1
ELELEF	CE - EN 567 - EN 12841/B	225	for left-handed people	Ø8/Ø13 Ø0.31-Ø0.51	1

Also available in the EAC version.



ELELEF

ELERIG

BELLY



VENTRAL LOCKING DEVICE

- Excellent locking ability even on rope that are particularly muddy thanks to the evacuation grooves in the cam
- Excellent wear resistance and increased strength thanks to a new thermal and chemical treatment applied to the material
- Ergonomic click opening mechanism, easy to operate and protected against impact and accidental opening

CODES AND DIMENSIONS

CODE	standard	weight [g]	rope diameter [mm]	pcs
BELLY	CE - EN 567 - EN 12841/B	150	Ø8/Ø13 Ø0.31-Ø0.51	1

Also available in the EAC version.



FOOT STEP

MULTI-PURPOSE BRACKET FOR ASCENT

- Compact and lightweight adjustable multi-purpose bracket in a practical bag that can be attached to the harness
- Made with 3 mm Kevlar rope and equipped with a pedal and adjustment buckle in ultra-resistant nylon

CODES AND DIMENSIONS

CODE	material	weight [g]	pcs
FOOTSTEP	kevlar/nylon	110	1



TRIPODS AND CRANES

TRI

MOBILE DEVICE WITH THREE FEET FOR LOWERING, LIFTING AND RECOVERY

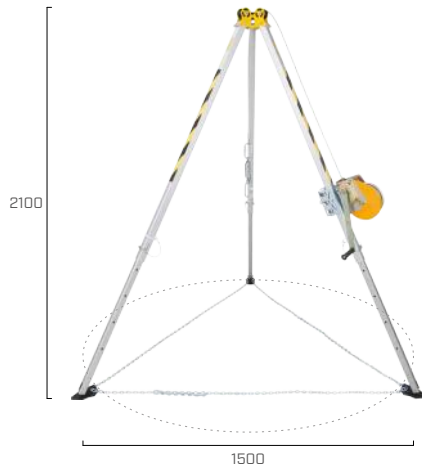

TRI2115

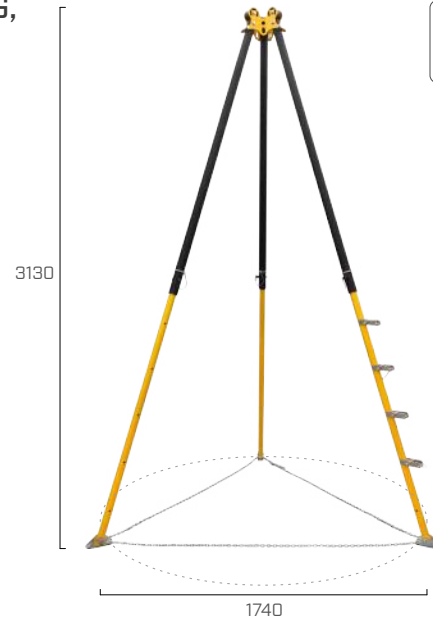

TRI3117

CODES AND DIMENSIONS

	TRI2115	TRI3117
description	tripod H _{max} = 210 cm	tripod H _{max} = 313 cm
materials	painted aluminium/zinc plated steel/polyamide	painted aluminium/zinc plated steel/stainless steel/polyamide
height [cm]	153 - 210	197 - 313
foot diameter [cm]	109 - 150	112 - 174
space between feet [cm]	200	206
weight [kg]	15,45	28,7
anchor points	3	3
number of workers	3	3
transport dimensions [cm]	175 x 25 x 25	226 x 33 x 30

CODE	description	material	weight [kg]	pcs
TRIUB	universal adapter for attaching accessories	zinc-plated steel	2,25	1

CODE	description	standard	cable length		cable diameter		cable type	ratio	weight	max. load capacity	pcs
			[m]	[ft]	[mm]	[in]			[kg]	[kg]	
TRIDAVFAL15B	adapter for retractable device TRIDAVFAL15	-	-	-	-	-	-	-	-	-	1
TRIDAVFAL15	retractable fall arrest device	EN 360; EN1496-B	15	49' 2 1/2"	4,8	0.19	7 x 19 + IWRC	1:8,8	11,0	140	1
TRIDAVFAL25B	adapter for retractable device TRIDAVFAL25	-	-	-	-	-	-	-	-	-	1
TRIDAVFAL25	retractable fall arrest device	EN 360; EN1496-B	25	82' 1/4"	4,8	0.19	7 x 19 + IWRC	1:7,4	15,0	140	1
TRIDAVWIN30E	automatic electric winch	-	30	98' 5 1/8"	6	0.24	steel	-	21	500	1
TRIDAVWIN15AC	automatic cordless winch	-	15	49' 2 1/2"	5	0.20	steel	-	10	140	1
TRIDAVWIN520	lifting winch	-	20	65' 7 3/8"	6,3	0.25	6 x 19 + NFC	1:6	13,0	140	1
TRIDAVWIN525	lifting winch	-	25	82' 1/4"	6,3	0.25	6 x 19 + NFC	1:5	14,0	140	1
TRIDAVWINU	universal winch for textile ropes	EN 1891-B	unlimited		10	0.39	textile static rope	1:40	-	-	1
TRIDAVWIN725	winch with recovery	EN 1496-B	25	82' 1/4"	6,3	0.25	6 x 19 + NFC	1:7,2	22,5	200	1
TRIDAVWIN735	winch with recovery	EN 1496-B	35	114' 10"	6,3	0.25	6 x 19 + NFC	1:7,2	24,5	200	1
TRIDAVWIN745	winch with recovery	EN 1496-B	45	147' 7 5/8"	6,3	0.25	6 x 19 + NFC	1:7,2	25,3	200	1
TRIDAVWIN750	winch with recovery	EN 1496-B	50	164' 1/2"	6,3	0.25	6 x 19 + NFC	1:7,2	26,2	200	1

ACCESSORIES INSTALLATION DIAGRAM



TRI2115



TRI3117

COMPATIBLE DEVICES



TRIUB
universal adapter
(one for each accessory)

RETRACTABLE FALL ARREST DEVICES WITH RECOVERY FUNCTION



TRIDAVFAL15B

+



TRIDAVFAL25B

+



TRIDAVFAL15



TRIDAVFAL25

DEVICES FOR LIFTING AND RECOVERY



TRIDAVWIN525

DEVICES FOR LIFTING



TRIDAVWIN725



TRIDAVWINU



TRIDAVWIN30E



TRIDAVWIN15AC

TRIPODS AND CRANES

DAV

CRANE FOR LIFTING PEOPLE AND LOADS

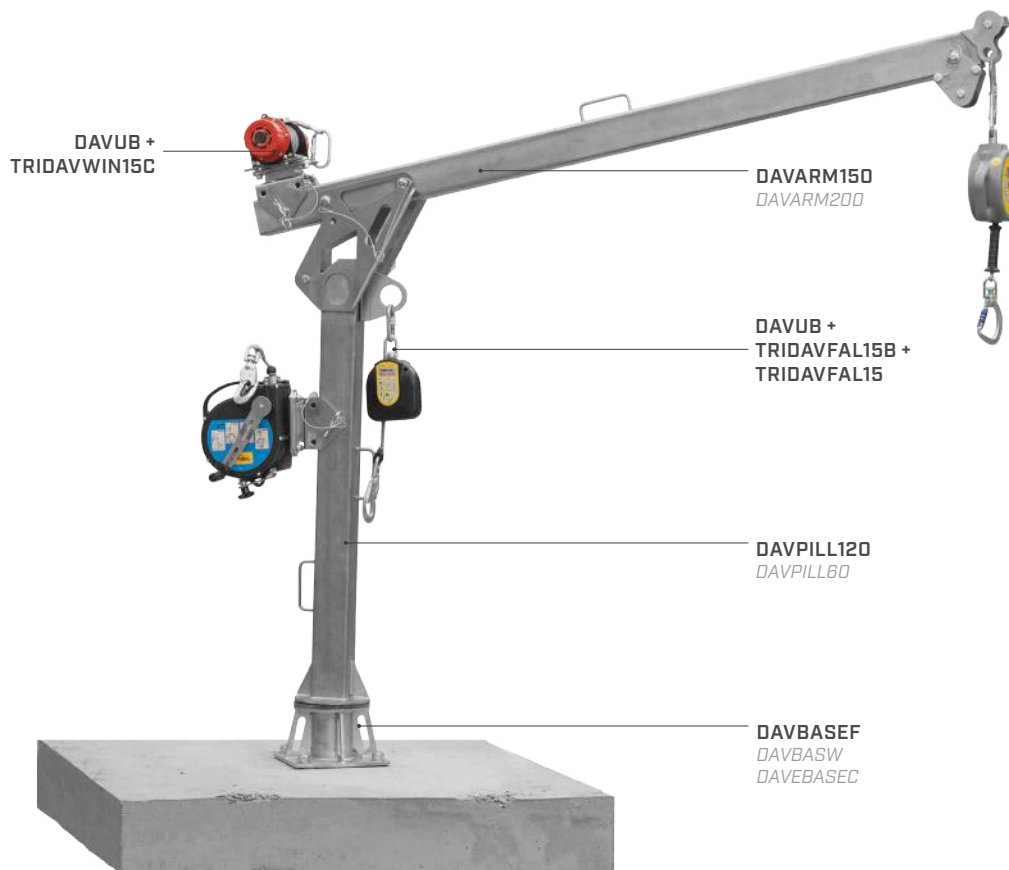

DAVCOVER

CODES AND DIMENSIONS

CODE	description	length		height		weight [kg]	max. material load [kg]	maximum person load [kg]	no. of operators	pcs
		[cm]	[in]	[cm]	[in]					
DAVARM150	crane jib length 150 cm	150	59 1/16	-	-	20,7	500	140	3	1
DAVARM200	crane jib length 200 cm	200	78 3/4	-	-	26,7	300	100	1	1
DAVDPILL120	crane mast height 120 cm	-	-	120	47 1/4	18,06	-	-	-	1
DAVDPILL60	crane mast height 60 cm	-	-	60	23 5/8	25,5	-	-	-	1
DAVBASEW	wall support for DAV	-	-	21,8	8 9/16	11,45	-	-	-	1
DAVBASEF	floor support for DAV	-	-	17	6 3/4	10,6	-	-	-	1
DAVBASEC	support for DAV that can be attached	-	-	-	-	-	-	-	-	1
DAVCOVER	PVC cover for DAV	-	-	-	-	-	-	-	-	1
DAVUB	universal adapter for DAV accessories	-	-	-	-	-	-	-	-	1

ACCESSORIES INSTALLATION DIAGRAM

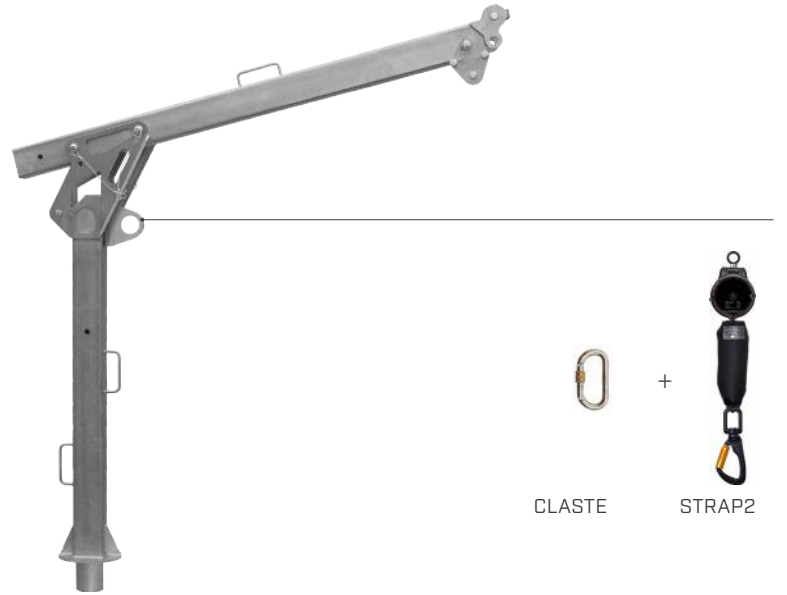

CLASTE

STRAP2

FLOOR SUPPORT

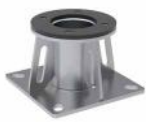

DAVBASEF

WALL SUPPORT



DAVBASEW

HOOKED HOLDER



DAVBASEC

* For more detail see page 202 and 197.

COMPATIBLE DEVICES



DAVUB
Universal adapter
(one for each accessory)

RETRACTABLE FALL ARREST DEVICES WITH RECOVERY FUNCTION



TRIDAVFAL15B



TRIDAVFAL25B

+

+



TRIDAVFAL15



TRIDAVFAL25

DEVICES FOR LIFTING AND RECOVERY



TRIDAVWIN525

DEVICES FOR LIFTING



TRIDAVWIN725



TRIDAVWINU



TRIDAVWIN30E



TRIDAVWIN15AC

* For more detail see page 210.

TRIPODS AND CRANES

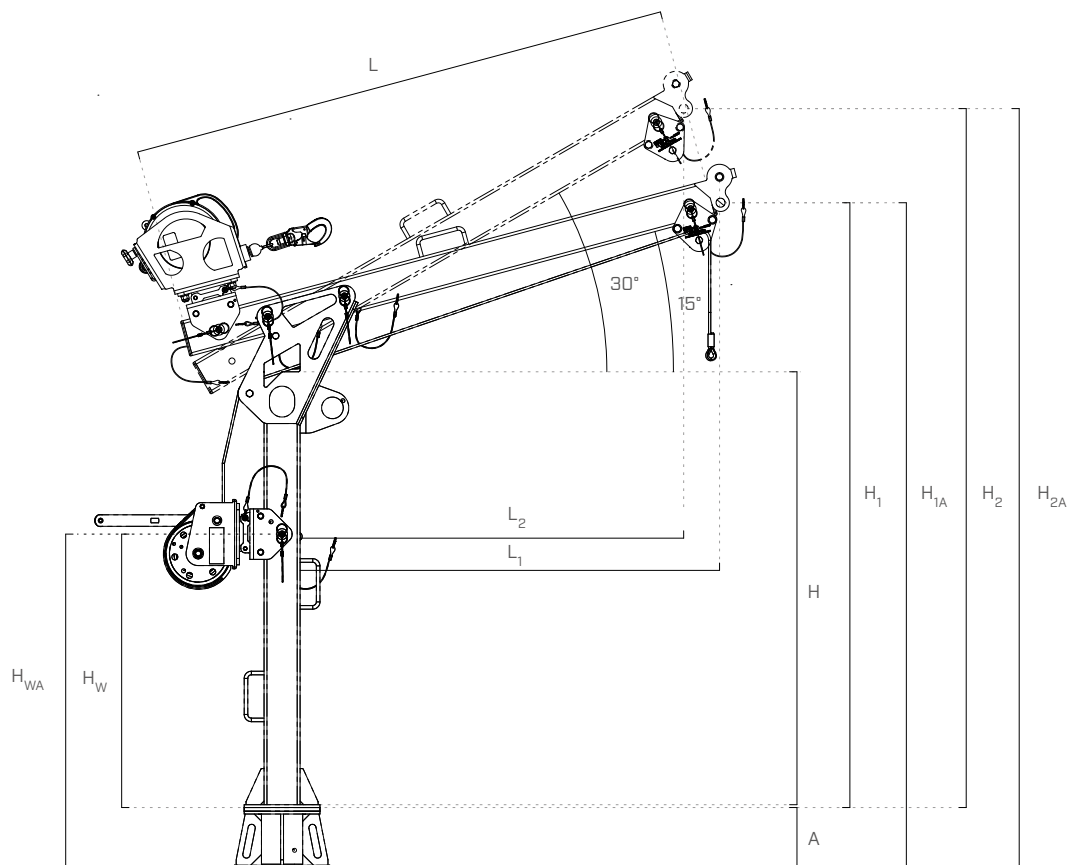

CODES AND DIMENSIONS | DIMENSIONS OF DAV COMBINATIONS

COMBINATION

H_{1A}	[m]	1,3	1,42	1,9	2,02	1,25	1,38	1,85	1,98
H_{2A}	[m]	1,56	1,81	2,16	2,41	1,51	1,76	2,11	2,36
weight	[kg]	50,22	56,21	57,66	63,65	49,43	55,42	56,87	62,86

ARM REFERENCE

		DAVARM150	DAVARM200	DAVARM150	DAVARM200	DAVARM150	DAVARM200	DAVARM150	DAVARM200
L	[m]	1,50	2,00	1,50	2,00	1,50	2,00	1,50	2,00
weight	[kg]	20,7	26,7	20,7	26,7	20,7	26,7	20,7	26,7
L₁	[m]	1,16	1,65	1,16	1,65	1,16	1,65	1,16	1,65
L₂	[m]	1,06	1,50	1,06	1,50	1,06	1,50	1,06	1,50
H₁	[m]	1,08	1,21	1,68	1,81	1,08	1,21	1,68	1,81
H₂	[m]	1,34	1,59	1,94	2,19	1,34	1,59	1,94	2,19

UPRIGHT REFERENCE

		DAVPILL120	DAVPILL60	DAVPILL120	DAVPILL60
H	[m]	0,6	1,2	0,6	1,2
H_w	[m]	0,36	0,75	0,36	0,75
H_{WA}	[m]	0,58	0,97	0,53	0,92
weight	[kg]	18,06	25,5	18,06	25,5

BASES REFERENCE

		DAVBASEW	DAVBASEG
H	[m]	0,22	0,17
weight	[kg]	11,45	10,66

STRETCHER

ROLLABLE STRETCHER

- Rolling stretcher designed to adapt perfectly to rescue needs in complicated environments
- Increased thickness offering greater resistance to rubbing, greater protection of the rescued person, greater rigidity during handling, easy to clean and disinfect
- Suspension for vertical transport in shafts or tunnels and for horizontal winching, even from a helicopter. Easy maintenance thanks to separately replaceable components.



CODES AND DIMENSIONS

CODE	standard	material	maximum load	transport dimensions	weight	length		width		pcs
			[kg]		[kg]	[cm]	[in]	[cm]	[in]	
STRETCHER	(UE) 2017/745 regulation	PE - nylon	150	30x100 cm 11 3/4" x 38 3/8"	7,3	245	96 7/16	92	36 1/4	1

LIFTING HELP

PREASSEMBLED LIFTING SYSTEM

- Preassembled system that allows a load to be lifted by applying force equal to 1/5 of the load itself
- The self-blocking device impedes the load from returning to its previous position



LIFTHelp

LIFTHelp2

CODES AND DIMENSIONS

CODE	ratio	weight	rope diameter		maximum length		pcs
		[g]	[mm]	[in]	[m]	[ft]	
LIFTHelp	5 to 1	1820	10	0.39	3	9' 10 1/8"	1
LIFTHelp2	5 to 1	1220	10	0.39	2	6' 6 3/4"	1

ACCESSORIES

TOOLGRAB

FALL PROTECTION FOR TOOLS

- Allows tools to be secured during work at height
- The variety of devices available in the range and their adaptability ensure a solution for any tool
- TOOLGRAB devices improve the comfort and safety of work at height, increasing user performance



TGAN60



TGAN100



TGAN300



TGSPRING



TGRING



TGTAPE



TGCC20



TGSS20



TGSL15



TGCL35

CODES AND DIMENSIONS

CODE	description	material	length [mm] [in]	width [mm] [in]	capacity [kg]	pcs
TGAN60	webbing with ring for fastening with tape L = 60 mm	polyester stainless steel	60 2 3/8	15 9/16	0,9	1
TGAN100	webbing with ring for fastening with tape L = 100 mm		100 4	25 1	4,5	1
TGAN300	webbing with ring L = 300 mm	polyester stainless steel	300 11 3/4	15 9/16	4,5	1
TGSPRING	coiled lanyard with double carabiner	stainless steel polyurethane aluminium	480 - 1220 19 - 48	Ø5,2 Ø0.21	0,9	1
TGRING	openable ring in plastic-coated stainless steel	stainless steel polyurethane	155 6 1/8	Ø2 Ø0.08	0,9	1
TGTAPE	silicone anchor tape	silicone tool tape with fibre	3000 118 1/8	25 1	-	1
TGCC20	elastic tool lanyard with double-action carabiners	polyester aluminium	900 - 1400 35 1/2 - 55 1/8	20 13/16	9,0	1
TGSS20	elastic tool lanyard with double-action swivel carabiners	polyester aluminium	900 - 1400 35 1/2 - 55 1/8	20 13/16	9,0	1
TGSL15	elastic tool lanyard with double-action carabiner	polyester aluminium	900 - 1200 35 1/2 - 47 1/4	15 9/16	6,8	1
TGCL35	elastic tool lanyard with double-action carabiner for heavy tools		900 - 1200 35 1/2 - 47 1/4	28 1 1/8	15,8	1

EXTEND

TELESCOPIC BAR

- Simplified assembly of the EXTENSIONHEAD by means of a screw system
- Locking of a particular section of the telescopic pole, possible in any position



EXTENSIONHEAD



EXTENSIONHOOK



EXTENSIONPOLE

CODES AND DIMENSIONS

CODE	standard	description	weight [g]	length min/max [mm] [in]	pcs
EXTENSIONPOLE	EN 62193 - EN 60832-1	telescopic bar	3,84	2060/8076 81 1/8 - 318	1
EXTENSIONHEAD	-	hook for hanging	-	-	1
EXTENSIONHOOK	CE - EN 795:2012 B	work hook	0,5	-	1

SINGLE - DOUBLE

ALUMINIUM PULLEY WITH SINGLE - DOUBLE SHEAVE

- Aluminium pulleys with movable single and double sheave flanges and high-efficiency ball bearings (96%)
- For ropes of max. 13 mm diameter
- DOUBLE version with 2 attachment points for use with complex lifting systems



SINGLE



DOUBLE



CODES AND DIMENSIONS

CODE	standard	body/pulley material	weight [g]	Q _r [kN]	rope diameter [mm] [in]	pcs
SINGLE	CE - EN 12278	aluminium alloy	245	30	max. Ø13 max. Ø0.51	1
DOUBLE	CE - EN 12278	aluminium alloy	490	50	max. Ø13 max. Ø0.51	1

ACCESSORIES

GLASS 1

GLASSES WITH TEMPLES WITH PANORAMIC FRAME

CE



CODES AND DIMENSIONS

CODE	standard	pcs
GLASS1	CE - EN 166	1

GLASS 2

GLASSES WITH TEMPLES WITH SMOKED LENSES

CE



CODES AND DIMENSIONS

CODE	standard	pcs
GLASS2	CE - EN 166	1

HEADPHONE

FOLDING EAR MUFFS

CE



CODES AND DIMENSIONS

CODE	standard	SNR [dB]	pcs
HEAD	CE - EN 352-1	29	1

RSBAG

WATERPROOF BAG

- Extremely robust
- Internal document pocket



CODES AND DIMENSIONS

CODE	weight [g]	capacity [L]	H [mm]	H [in]	pcs
RSBAG	610	30	700	27 1/2	1

RBBAG

BACKPACK

- Complete with hook for lifting
- Extremely light and comfortable

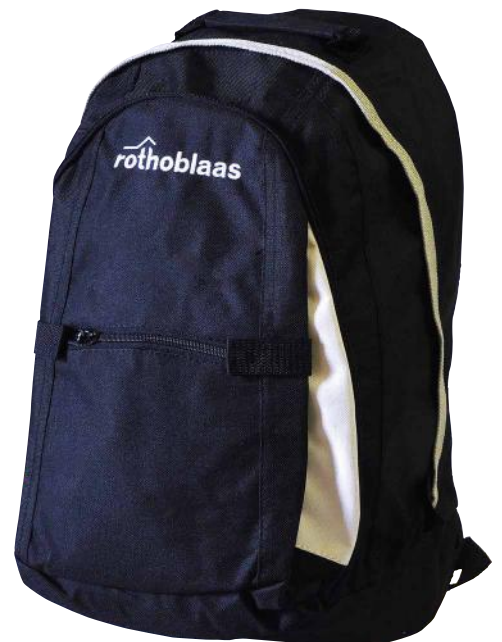

CODES AND DIMENSIONS

CODE	weight [g]	capacity [L]	H [mm]	H [in]	pcs
RBBAG	390	23,6	400	15 3/4	1

ACCESSORIES

GLOVE BASE

POLYAMIDE/NITRILE FOAM GLOVES

- Work gloves
- Ensures comfort and precision in dry, low-oil mechanical work environments
- Features Actifresh technology to counteract the spread of bacteria and ensure an ergonomic fit



CODES AND DIMENSIONS

CODE	size	pair
GLOBASE8	8	1
GLOBASE9	9	1
GLOBASE10	10	1



EN 388:2016



4X31A

EN 407:2020



X1XXXX

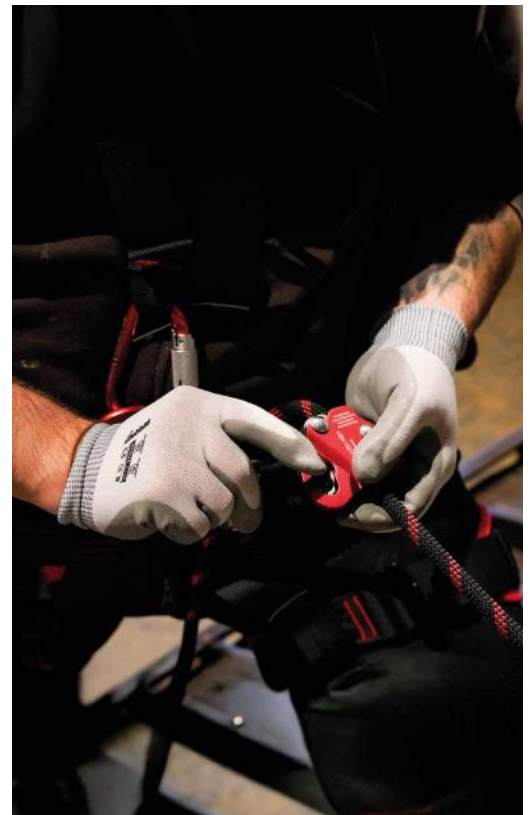

GLOVE MID

RECYCLED NYLON&SPANDEX/NITRILE FOAM GLOVES

- Protective work gloves
- The nitrile foam composition and soft lining ensure excellent fingertip sensitivity
- They provide a secure grip, are antibacterial and are made with 50% recycled material



CODES AND DIMENSIONS

CODE	size	pair
GLOMID8	8	1
GLOMID9	9	1
GLOMID10	10	1



EN 388:2016



4X31A

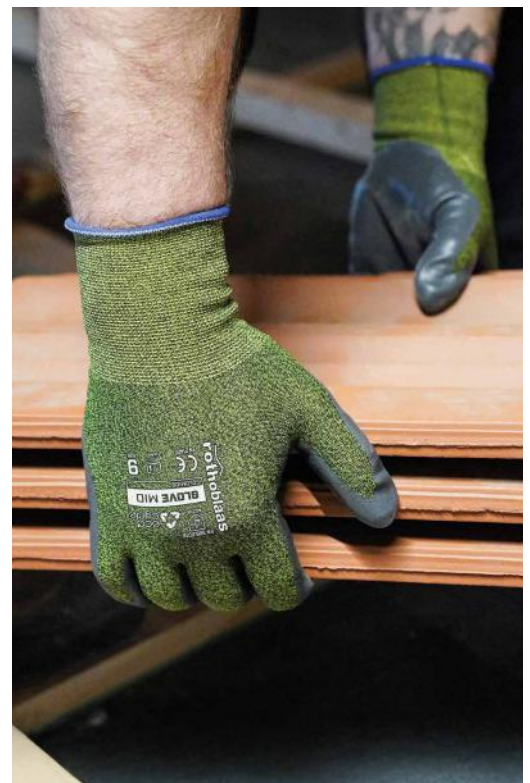

GLOVE PRO

HPPE, STEEL FIBRE AND POLYESTER/NITRILE FOAM GLOVES

- Cut-resistant protective gloves
- Ideal for protecting hands from cuts in dry or low-oil work environments
- The thin structure ensures a proper fit, optimal comfort and good dexterity in cold conditions



EN 388:2016



EN 407:2020



CODES AND DIMENSIONS

CODE	size	pair
GLOPRO8	8	1
GLOPRO9	9	1
GLOPRO10	10	1

KEY TO SYMBOLS

EN 388:2016



3 X 3 1 A

Properties	Evaluation
Abrasion	1-4
Cut	1-5
Wear	1-4
Puncture resistance	1-4
Cut (TDM-100 test)	A-F

X Property not assessed

EN 407:2020



X 1 X X X X

Properties	Evaluation
Burning behaviour (resistance to flammability)	1-4
Contact heat	1-4
Convective heat test	1-4
Radiant heat test	1-4
Small drops molten metal	1-4
Large quantity molten metal	1-4

X Property not assessed

ACCESSORIES

VEST



HIGH-VISIBILITY GARMENT

MAXIMUM VISIBILITY

This vest, made from neon fabric and equipped with 2-inch reflective strips, ensures excellent visibility even in low-light conditions.

COMFORTABLE

Made of 100% polyester tricot, this vest offers excellent breathability and durability.

VERSATILE

The multipurpose pockets, zipper closure and wide range of sizes and colours ensure a perfect fit for everyone.

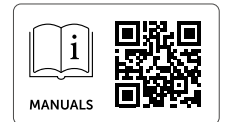

CODES AND CHARACTERISTICS

CODE	standard	material	colour	size	A		B		pcs
					[cm]	[in]	[cm]	[in]	
VESTOZIPM	CE EN ISO 20471:2013 + A1:2016 Class 2	polyester	●	M	108-116	42 1/2 - 45 11/16	165-170	65 - 67	1
VESTOZIPL		polyester	●	L	116-124	45 11/16 - 48 13/16	170-175	67 - 69	1
VESTOZIPXL		polyester	●	XL	124-132	48 13/16 - 52	175-180	69 - 71	1
VESTOZIPXXL		polyester	●	XXL	132-140	52 - 55 1/8	180-185	71 - 72 13/16	1
VESTYZIPM		polyester	●	M	108-116	42 1/2 - 45 11/16	165-170	65 - 67	1
VESTYZIPL		polyester	●	L	116-124	45 11/16 - 48 13/16	170-175	67 - 69	1
VESTYZIPXL		polyester	●	XL	124-132	48 13/16 - 52	175-180	69 - 71	1
VESTYZIPXXL		polyester	●	XXL	132-140	52 - 55 1/8	180-185	71 - 72 13/16	1

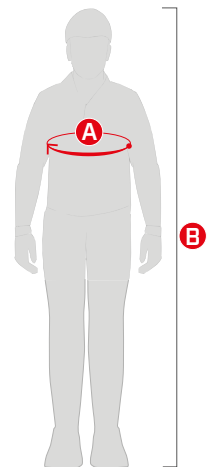

VESTOZIPM
VESTOZIPL
VESTOZIPXL
VESTOZIPXXL

VESTYZIPM
VESTYZIPL
VESTYZIPXL
VESTYZIPXXL



COMPLEMENTARY PRODUCTS

COMPLEMENTARY PRODUCTS

TOOLS



FLY

page 230 <



MAMMOTH

page 230 <



MAMAUTO600

page 230 <



CAT

page 231 <



PONY

page 231 <



BRUH

page 231 <



SNAIL PULSE

page 232 <



DUHXA

page 233 <



SNAIL METAL

page 233 <



CRICKET

page 234 <



SOCKET

page 234 <



BEAR

page 235 <



TORSMART

page 235 <



ROPE CLAMP

page 236 <



CABLE CLAMP

page 236 <



CANARY

page 236 <



FINCH

page 237 <



BIRD

page 237 <



WREN

page 237 <



BENDTOOL

page 238 <



TORQUE LIMITER

page 239 <



ESTRO

page 240 <

MACHINES



A 12

page 242 <



A 18 | ASB 18

page 242 <



ERIKA 85

page 243 <



KSS 40

page 243 <



HOT GUN

page 244 <



P 26 C

page 244 <



TARGA
page 246 <



GREASE
page 247 <

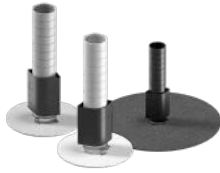

MANICA
page 248 <



MANICA ROLL
page 249 <



MANICA LEAD
page 249 <



MANICA POST
page 249 <



TOWER PEAK
page 250 <



TOWER SLOPE
page 250 <



TOWLATEVO
page 251 <



TOPLATE
page 251 <



TOPLATE 2.0
page 252 <



TRAPD
page 252 <



MULTIPLATE
page 253 <



BEF
page 254 <



SPARE PARTS
page 255 <



SCREW-IN ANCHORS
from page 256 <



HEAVY ANCHORS
from page 258 <



CHEMICAL ANCHORS
from page 260 <



INA
page 261 <

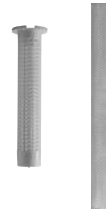

IHP - IHM
page 261 <



PARTIAL THREAD SCREWS
from page 264 <



FULLY THREADED SCREW
from page 266 <



SCREWS FOR METAL SHEET
from page 267 <



SCREWS FOR PLATES
from page 268 <



THREADED RODS
from page 269 <



WASHERS
from page 270 <



NUTS
from page 271 <



BOLTS
from page 272 <

TOOLS

A COMPLETE, STEP-BY-STEP GUIDE TO INSTALLING OUR FALL PROTECTION SYSTEMS

STEP 1

TRACKING AND DRILLING

ANCHOR POINTS



PATROL VERTIGRIP



H-RAIL BORDER STEP UP



A18 | ASB18

CORDLESS SCREWDRIVER
see page 242



P 26 C

COMBI HAMMER
see page 244



SNAIL METAL

HSS HIGH-SPEED STEEL TWIST DRILL BIT
see page 233



SNAIL PULSE

CARBIDE DRILL BIT IN HM WITH SDS-PLUS DRILL CHUCK SHANK
see page 232

STEP 2

HOLE CLEANING



BRUH

STEEL PIPE CLEANER
see page 231



CAT

COMPRESSED AIR TOOL
see page 231



PONY

BLOW PUMP FOR HOLE CLEANING
see page 231



STEP 3

FASTENING AND ASSEMBLY OF SUPPORTS



MAMMOTH

SPECIAL GUN FOR 400 mL CARTRIDGES
see page 230



MAMAUTO600

BATTERY-OPERATED RESIN GUN
see page 230



INA

THE THREADED ROD FOR CHEMICAL ANCHORS
see page 261



VIN-FIX

VINYL ESTER CHEMICAL ANCHOR WITHOUT STYRENE
see page 260



CRICKET

8 SIZES RATCHETING WRENCH
see page 234



BIRD

BATTERY-OPERATED RIVETING MACHINE
see page 237



TORQUE LIMITER

TORQUE LIMITER
see page 239

STEP 4

**FASTENING CHECK
ON SEPARATE SAMPLE**



ESTRO
PORTABLE DIGITAL
PULL-OUT TESTER
see page 240



TORSMART
DIGITAL ADAPTER FOR
TIGHTENING TORQUE
CONTROL
see page 235



STEP 5

**COMPLETE SYSTEM
INSTALLATION**



BEAR
TORQUE WRENCH
see page 235



SOCKET
BUSHINGS AND BITS
see page 234



CRICKET
8 SIZES RATCHETING
WRENCH
see page 234



STEP 6

**CABLE
TENSIONING**



ROPE CLAMP
CABLE TENSIONER FOR LIFELINE
see page 236



CABLE CLAMP
STEEL ROPE CLAMP
see page 236



STEP 7

**FINAL
CUT**



CANARY
SINGLE-HANDED
SHEARS FOR WIRE
ROPES
see page 236



ERIKA 85
PULL-PUSH TABLE SAW
see page 243



KSS 40
BATTERY-OPERATED
CROSS-CUTTING SAW
see page 243



FLY

PROFESSIONAL GUN FOR 310 mL CARTRIDGES

- The FLY sealant gun is designed for 310 mL cartridges
- Made from strong materials, it ensures practical and efficient use

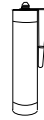

CODES AND CHARACTERISTICS

CODE	description	pcs
FLY	for cartridges of 310 mL	1



MAMMOTH

SPECIAL GUN FOR 400 mL CARTRIDGES

- Specifically designed for 400 mL cartridges
- Robust and durable, it allows precise application of resin



CODES AND CHARACTERISTICS

CODE	description	pcs
MAM400	for cartridges of 400 mL	1



MAMAUTO600

BATTERY-OPERATED RESIN GUN

- 7.4V/1.3 Ah lithium battery
- Adjustable forward speed (1-6)
- It supports up to 30 x 310 mL cartridges or 20 x 600 mL soft cartridges per battery charge

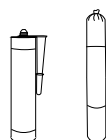

CODES AND CHARACTERISTICS

CODE	description	pcs
MAMAUTO600	for 310 mL cartridges and soft cartridges up to 600 mL	1



CAT

COMPRESSED AIR TOOL

- The installation with CAT makes it possible to obtain the maximum certified performances even with cracked concrete

CODES AND CHARACTERISTICS

CODE	description	length		pcs
		[mm]	[in]	
CAT500	compressed air tool	500	19 3/4	1



PONY

POCKET AIR PUMP FOR HOLE CLEANSING

- Cleaning the holes by blowing is necessary before installing heavy chemical anchors

CODES AND CHARACTERISTICS

CODE	pcs
PONY	1



BRUH

STEEL PIPE CLEANER

- Stainless steel
- Allows certified installation with PONY blow pump and CAT compressed air tool gun

CODE	rod	internal thread bushing	d ₀		L		pcs
	[mm]	[mm]	[mm]	[in]	[mm]	[in]	
BRUH10	M8	-	10	0.4	150	6	1
BRUH12	M10	-	12	0.48	150	6	1
BRUH14	M12	IR-M8	14	0.56	150	6	1
BRUH18	M16	IR-M10	18	0.71	150	6	1
BRUH22	M20	IR-M12	22	0.87	150	6	1
BRUH28	M24	IR-M16	28	1.11	150	6	1
BRUH30	M27	-	30	1.19	150	6	1
BRUH35	M30	-	35	1.38	150	6	1

d₀ = hole diameter in the support



ADDITIONAL PRODUCTS - ACCESSORIES

CODE	description	pcs
BRUHAND	grip and extension for pipe cleaner	1

SNAIL PULSE

CARBIDE DRILL BIT IN HM WITH SDS-PLUS DRILL CHUCK SHANK

- For drilling concrete, reinforced concrete, masonry and natural stone
- The 4 spiral HM cutting edges ensure rapid forward movement



CODES AND CHARACTERISTICS

CODE	Ø tip		TL		EL		pcs
	[mm]	[in]	[mm]	[in]	[mm]	[in]	
DUHPV505	5	0.197	115	4 1/2	50	2	1
DUHPV510	5	0.197	165	6 1/2	100	4	1
DUHPV605	6	0.236	115	4 1/2	50	2	1
DUHPV610	6	0.236	165	6 1/2	100	4	1
DUHPV615	6	0.236	215	8 7/16	150	6	1
DUHPV810	8	0.315	165	6 1/2	100	4	1
DUHPV815	8	0.315	215	8 7/16	150	6	1
DUHPV820	8	0.315	265	10 7/16	200	8	1
DUHPV840	8	0.315	465	18 5/16	400	15 3/4	1
DUHPV1010	10	0.394	165	6 1/2	100	4	1
DUHPV1015	10	0.394	215	8 7/16	150	6	1
DUHPV1020	10	0.394	265	10 7/16	200	8	1
DUHPV1040	10	0.394	455	17 15/16	390	15 3/8	1
DUHPV1210	12	0.472	160	6 1/4	110	4 3/8	1
DUHPV1215	12	0.472	210	8 1/4	160	6 1/4	1
DUHPV1220	12	0.472	260	10 1/4	210	8 1/4	1
DUHPV1240	12	0.472	450	17 3/4	400	15 3/4	1
DUHPV1410	14	0.551	160	6 1/4	110	4 3/8	1
DUHPV1420	14	0.551	260	10 1/4	210	8 1/4	1
DUHPV1440	14	0.551	450	17 3/4	400	15 3/4	1
DUHPV1625	16	0.630	310	12 3/16	260	10 1/4	1
DUHPV1640	16	0.630	450	17 3/4	400	15 3/4	1
DUHPV1820	18	0.709	250	10	200	8	1
DUHPV1840	18	0.709	450	17 3/4	400	15 3/4	1
DUHPV2020	20	0.787	250	10	200	8	1
DUHPV2040	20	0.787	450	17 3/4	400	15 3/4	1
DUHPV2240	22	0.866	450	17 3/4	400	15 3/4	1
DUHPV2440	24	0.945	450	17 3/4	400	15 3/4	1
DUHPV2540(*)	25	0.984	450	17 3/4	400	15 3/4	1
DUHPV2840(*)	28	1.102	450	17 3/4	400	15 3/4	1
DUHPV3040(*)	30	1.181	450	17 3/4	400	15 3/4	1

(*)Only for DUP26C and DUP26SDS.



SNAIL PULSE SET

CODE	Ø drill bit (TL) [mm]	pcs
DUSDSV7T	Ø5 (115 mm), Ø6 (115 mm), Ø6 (165 mm), 2 x Ø8 (165 mm), Ø10 (165 mm), Ø12 (160 mm)	1

TL total length
EL effective length



DUHXA

HOLLOW DUST EXTRACTION DRILL BIT FOR CONCRETE WITH SDS-MAX SHANK

- It combines two steps in one: drilling and suction in a single operation
- Significantly higher drilling speed due to optimal dust removal
- Dust-free working environment to protect the user
- Universal adapter for vacuum cleaner fits all common industrial vacuum cleaners



DUIS35M

CODES AND CHARACTERISTICS

CODE	rod	internal thread bushing	d ₀		EL		TL		pcs
	[mm]	[mm]	[mm]	[in]	[mm]	[in]	[mm]	[in]	
DUHXA1840	M16	IR-M10	18	0.71	400	15 3/4	600	23 5/8	1
DUHXA2240	M20	IR-M12	22	0.87	400	15 3/4	600	23 5/8	1
DUHXA2840	M24	IR-M16	28	1.11	400	15 3/4	620	23 5/8	1
DUHXA3040	M27	-	30	1.19	400	15 3/4	620	23 5/8	1
DUHXA3540	M30	-	35	1.38	400	15 3/4	620	23 5/8	1

d₀ = hole diameter in the support

EL = useful length

TL = total length

ADDITIONAL PRODUCTS - ACCESSORIES

CODE	description	pcs
DUIS35M	class M suction system	1

SNAIL METAL

HSS HIGH-SPEED STEEL TWIST DRILL BIT

- Super-rapid steel drill bits for drilling holes in metal structures



CODES AND CHARACTERISTICS

CODE	Ø		TL		EL		pcs
	[mm]	[in]	[mm]	[in]	[mm]	[in]	
F2599103	3	0.118	150	6	100	4	1
F2599104	4	0.157	150	6	100	4	1
F2599105	5	0.197	150	6	100	4	1
F2599106	6	0.236	150	6	100	4	1
F2599107	7	0.276	150	6	100	4	1
F2599108	8	0.315	150	6	100	4	1
F2599109	9	0.354	150	6	100	4	1
F2599110	10	0.394	150	6	100	4	1
F2599111	11	0.433	150	6	100	4	1
F2599212	12	0.472	250	10	200	8	1
F2599213	13	0.512	250	10	200	8	1
F2599216	16	0.630	250	10	200	8	1



CRICKET

8 SIZES RATCHETING WRENCH

- Ratcheting wrench with through hole and 8 bushings of varying sizes
- 4 ring spanners in a single tool



CODES AND CHARACTERISTICS

CODE	dimensions / thread	length		pcs
	[SW / M]	[mm]	[in]	
CRICKET	10 / M6 - 13 / M8	340	13 3/8	1
	14 / (M8) - 17 / M10			
	19 / M12 - 22 / M14			
	24 / M16 - 27 / M18			

SOCKET

BUSHINGS AND BITS

CODES AND CHARACTERISTICS

CODE	wrench size	machine housing	length [mm]	pcs
SOCKET10	10	1/2"	40	1
SOCKET12	12	1/2"	40	1
SOCKET13	13	1/2"	40	1
SOCKET15	15	1/2"	40	1
1 SOCKET16	16	1/2"	40	1
SOCKET17	17	1/2"	40	1
SOCKET18	18	1/2"	40	1
SOCKET19	19	1/2"	40	1
SOCKET22	22	1/2"	40	1
SOCKET24	24	1/2"	40	1
2 SOCKETL13	13	1/2"	80	1
SOCKETL19	19	1/2"	80	1
SOCKETBIT	bit holder 1/4"	1/2"	-	1
3 SOCKETBIT38	bit holder 1/4"	3/8"	-	1
SOCKETBITL	5/16" driver bit holder	1/2"	-	1
4 HEX525	-	connector C 6.3 (1/4")	25	5
5 HEX514	3/8"	connector C 6.3 (1/4")	50	5



BEAR

TORQUE WRENCH

- Precise tightening torque control
- Wide adjustment range



BEAR



BEAR2

CODES AND CHARACTERISTICS

CODE	dimensions [mm]	weight [g]	tightening torque [Nm]	pcs
BEAR	395 x 60 x 60	1075	10 - 50	1
BEAR2	535 x 60 x 60	1457	40 - 200	1

With 1/2" square drive.



TORSMART

DIGITAL ADAPTER FOR TIGHTENING TORQUE CONTROL

- Digital torque meter for accurate tightening torque control
- TORSMART is positioned between the drill or wrench and the socket, and is easy to use.
- The torque is measured with precision, saved and analysed via an app. An audible signal alerts you when the set limit is reached

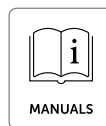

CODES AND CHARACTERISTICS

CODE	torque range [Nm]	pcs
TORSMART80	8 - 80	1

Torque range	8 - 80 Nm
Connection	3/8" (9,5mm)
Dimensions (diameter x length)	42 x 75 mm
weight	160 g

Power supply: rechargeable battery, supplied with USB charging cable - charger not supplied

It requires the Hydrajaws Verify app to work, which communicates with the device via Bluetooth®.



APP DOWNLOAD
Download the Hydrajaws Verify App to use TORSMART



ROPE CLAMP

CABLE TENSIONER FOR LIFELINE

- Used with the CABLE CLAMP, it facilitates cable clamping, and, by means of the lever, also allows pretensioning.

CODES AND CHARACTERISTICS

CODE	description	standard	material	load capacity [kg]	pcs
SPAN1	cable tensioner hoist	DIN EN 818-7	zinc-plated steel	250	1



CABLE CLAMP

STEEL ROPE CLAMP

- Used with the ROPE CLAMP, it facilitates cable clamping during pretensioning of the lifeline cable

CODES AND CHARACTERISTICS

CODE	description	pcs
CABLECLAMP	clamp for steel cable Ø5-10 mm	1



CANARY

SINGLE-HANDED SHEARS FOR WIRE ROPES

- Flexible wire ropes up to max. 13 mm
- Stainless steel, high-density wire ropes up to max. 10 mm

CODES AND CHARACTERISTICS

CODE	length [mm]	weight [kg]	pcs
CANARY	245	0,9	1

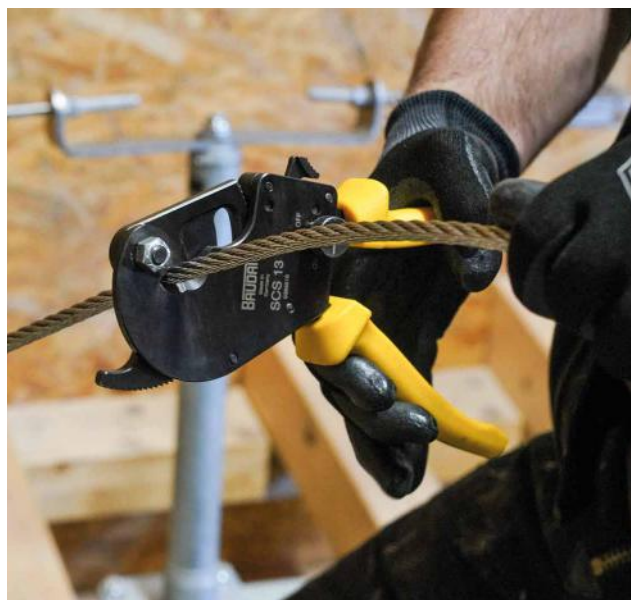

FINCH

PROFESSIONAL RIVETING MACHINE

- Light and manoeuvrable
- Ideal for large and structural rivets

CODES AND CHARACTERISTICS

CODE	Ø rivets [mm]	weight [kg]	pcs
FINCH3064	3,0 - 4,0 - 4,8 - 6,4	1,4	1



BIRD

BATTERY-OPERATED RIVETING MACHINE

- Ergonomic and lightweight
- Excellent manoeuvrability even in tight spaces
- Equipped with two batteries with charger
- Up to 1400 rivets on one charge



CODES AND CHARACTERISTICS

CODE	battery [Ah]	Ø rivets [mm]	weight [kg]	strength [N]	pcs
BIRD5277	2,0	5,2 - 6,4 - 7,7	2,15	12.000	1

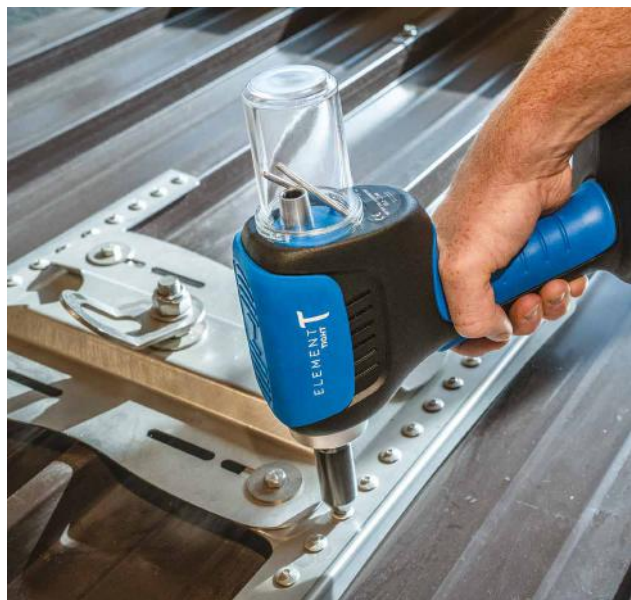

WREN

STAPLE PLIERS

- Pliers with dispenser for OVERSTAPLE joining staples

CODES AND CHARACTERISTICS

CODE	description	staple size [mm]	pcs
WREN	pliers with staple dispenser	20	1

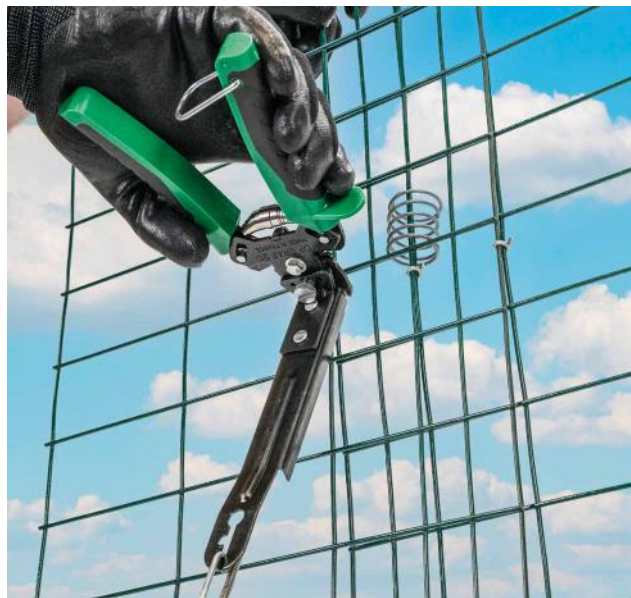

BENDTOOL

ADJUSTABLE ANGLE BRACKET BENDING TOOL

COMPACT

Its compact size and lightweight design make it easy to use on construction sites.

EASY TO USE

Its simple and understated design, together with the attached manual, ensure intuitive and practical use.

UNIVERSAL

Suitable for bending all angle brackets in the BEND series, from 90° to 180°, thanks to its compatibility with a wide range of screwdrivers.

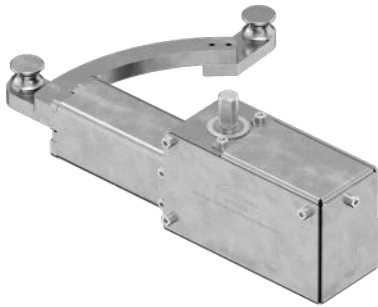

CODES AND CHARACTERISTICS

CODE	description	pcs
BENDTOOL	adjustable angle bracket bending tool	1

INSTRUCTIONS FOR USE

PASANGBEND

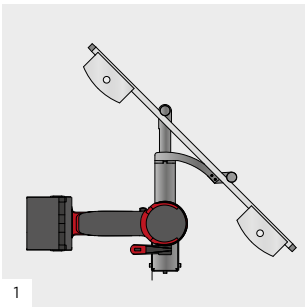

Place the support on BENDTOOL

PAREXBEND

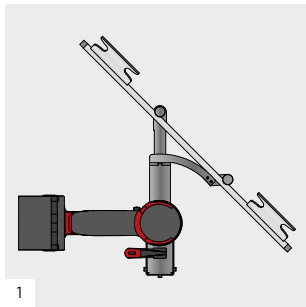

PARINBEND

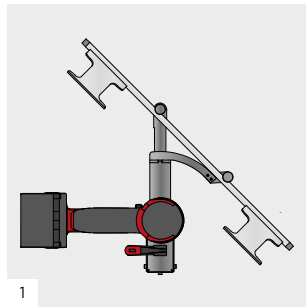

OHANGBEND

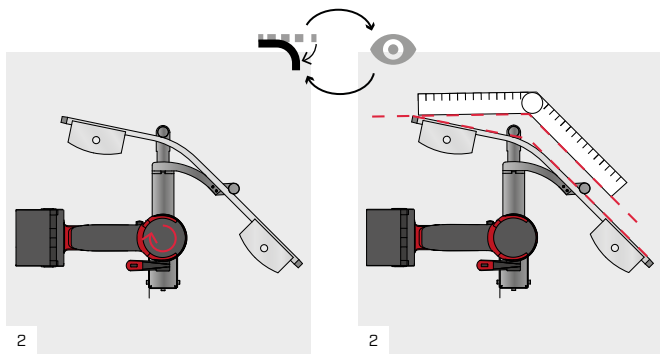
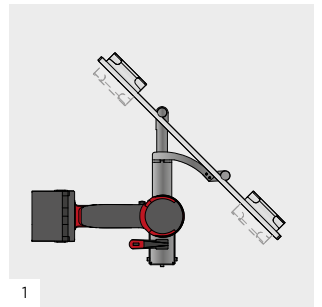

Proceed with bending gradually, constantly checking the angle with the help of a protractor.

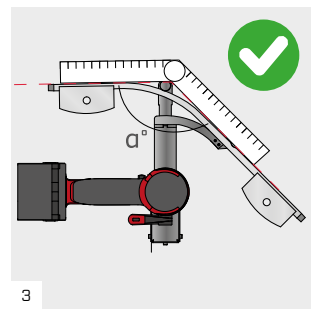

Repeat step 2 several times until the desired angle is reached.

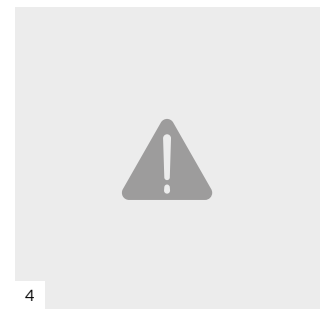

Attention! To achieve the desired bending angle it may be necessary to move the support, changing the bend point. Do not overbend: the device is not designed to straighten.

TORQUE LIMITER

TORQUE LIMITER

SAFE INSERTION

The TORQUE LIMITER allows safe screw tightening, preventing the risk of exceeding the torque limit, which is particularly useful in metal-to-timber connections.

UNIVERSAL USE - ALSO WITH CATCH

The TORQUE LIMITER comes with a standard bit but can also be easily used with the CATCH device for tightening long screws.

MINIMAL MAINTENANCE

Because of the internal clutch, the device is permanently lubricated and requires no regular maintenance.



CODES AND DIMENSIONS

CODE	stop torque [Nm]	L [mm]	weight [g]	pcs
1 TORLIM18 incl. TORLIMBIT + TX4050	18,0	120,5	1030	1
TORLIM40 incl. TORLIMBITL + TX5050	40,0	120,5	1030	1

ACCESSORIES

CODE	description	pcs
2 TORLIMBIT	1/4" bit holder adapter for TX40 bit	1
3 TORLIMBITL	5/16" bit holder adapter for TX50 bit	1
4 TORLIMSOCKET	1/2" square insert adapter	1

TECHNICAL DATA

	TORLIM18	TORLIM40
Machine support	SW 11 hexagonal head	SW 11 hexagonal head
Bit connection	SW 11 hexagonal head	SW 11 hexagonal head
Accessories included	TORLIMBIT, TX4050 bit, Allen key	TORLIMBIT, TX5050 bit, Allen key
Example of suitable screws ⁽¹⁾	HBS PLATE, HBS Ø8 - Ø10 mm VGZ, VGS Ø9 mm	HBS PLATE, HBS Ø12 mm VGZ, VGS Ø11 - Ø13 mm

⁽¹⁾ Fits any type of screw by choosing the version with trigger torque equal to or less than the recommended insertion moment for the screw in question. For the recommended insertion moments of each screw, see the TIMBER SCREWS AND DECK FASTENING catalogue.

For further information on use of the product, see www.rothoblaas.com.



PORTABLE DIGITAL PULL-OUT TESTER

SAFE TESTING

Allows tensile testing on a wide range of fasteners to ensure proper installation.

DIGITAL

Measured values can be saved in the dedicated app. It is an ideal tool for pull-out tests in compliance with standards BS 8539, BS 7883, BS EN 795 and AEFAC-TN05.

EXPANDABLE

With the additional bridge accessories, the testing capacity can be extended up to 65 kN.



ESTRO35BRIL

ESTRO35BRIM



APP DOWNLOAD

Download the Hydrajaws Verify App to use ESTRO



CODES AND CHARACTERISTICS

CODE	description	test capabilities [kN]	pcs
ESTRO35MET ⁽¹⁾	pull-out tester - metric system	35 kN with standard bridge	1
ESTRO35IMP ⁽²⁾	pull-out tester - imperial system	65 kN with medium/large bridge	1

⁽¹⁾ included:

- forked forks: 20 and 24 mm
- 5 slotted button adapters: 6,5, 8,5, 10,5, 13 and 16,5 mm
- 6 threaded button adapters: M6, M8, M10, M12, M16 and M20

⁽²⁾ included:

- forked forks: 20 and 24 mm
- 5 slotted button adapters: 6,5, 8,5, 10,5, 13 and 16,5 mm
- 6 threaded button adapters: 1/4", 5/16", 3/8", 1/2", 5/8", 3/4" UNC

COMPLEMENTARY PRODUCTS

CODE	description	pcs
ESTRO35BRIM	medium bridge	1
ESTRO35BRIL	large bridge	1

DIMENSIONS

**ESTRO35MET
ESTRO35IMP**

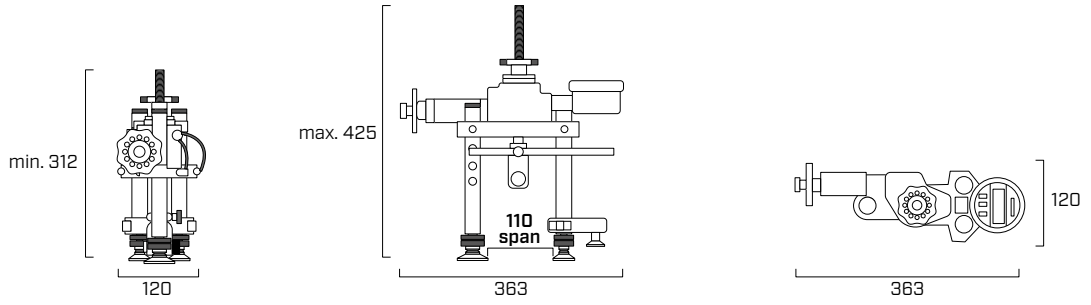

**with
ESTRO35BRIM**

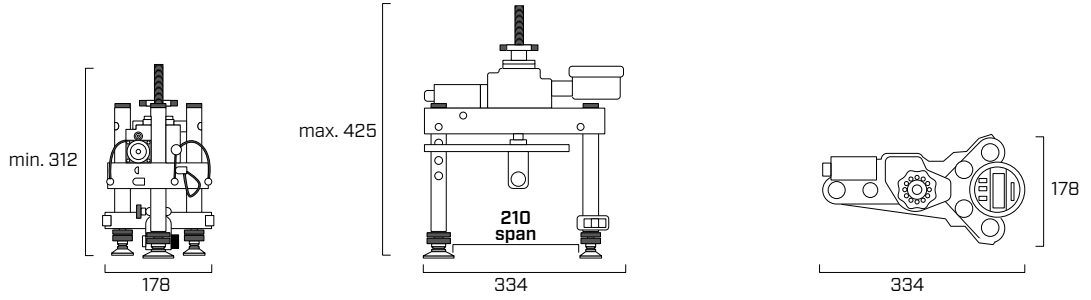

**with
ESTRO35BRIL**

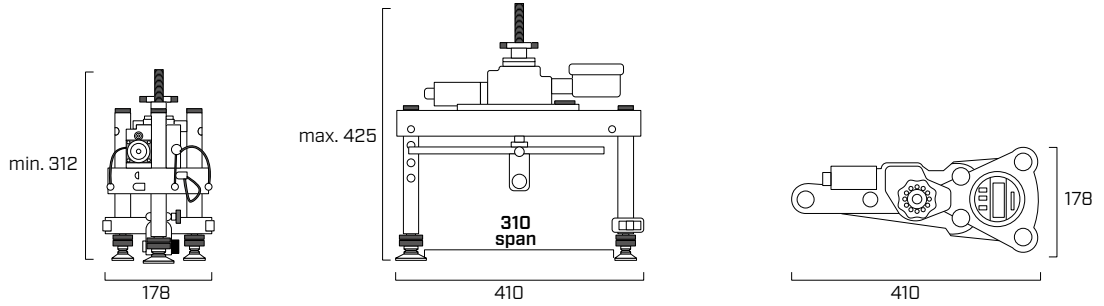

TECHNICAL DATA

Properties	values	USC units
Pull-out load range	0-35 kN	0-7.868 lbf
	0-65 kN	0-14.613 lbf
Maximum torque	a 35 kN = 9,8 Nm	a 35 kN = 7.2 ft-lbs
	a 65 kN = 18,8 Nm	a 65 kN = 13.9 ft-lbs
Operating temperature range	-10° C – +50° C	14° F – 122° F
Configurable units	kN	lbf
Weight (tester only)	3,7 kg	8.16 lbs

A 12

CORDLESS DRILL

- Soft / hard torque: **18/45 Nm**
- Nominal minimum 1st gear: **0 - 510 (1/min)**
- Nominal minimum 2° gear: **0 - 1710 (1/min)**
- Nominal tension: **12 V**
- Weight (including battery): **1,0 kg**

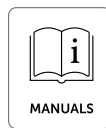

CODES

CODE	description	pcs
MA91D001	A 12 cordless screwdriver in T-MAX	1

For accessories, see the "Tools for timber construction" catalogue available at www.rothoblaas.com.



A 18 | ASB 18

CORDLESS DRILL

- Electronic anti-kickback function
- Soft / hard torque: **65/130 Nm**
- Nominal minimum 1st gear: **0 - 560 (1/min)**
- Nominal minimum 2° gear: **0 - 1960 (1/min)**
- Nominal tension: **18 V**
- Weight (including battery): **1,8 kg / 1,9 kg**



A 18



ASB 18

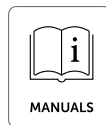

CODES

CODE	description	pcs
MA91C801	A 18 cordless screwdriver in T-MAX	1
MA91C901	ASB 18 percussion drill in T-MAX	1

For accessories, see the "Tools for timber construction" catalogue available at www.rothoblaas.com.



ERIKA 85

PULL-PUSH TABLE SAW

- Cut height: -1 - 85 mm
- Cut height 45°: -1 - 59 mm
- Slope angle: -3 - 48°
- Cut length: 430 mm
- Nominal no-load speed: 2050 - 4300 1/min
- Input power: 2500 W
- Weight: 40 kg
- Universal motor: 230 V / 50 Hz



CODES

CODE	description	pcs
MA971901	ERIKA 85 pull-push table saw	1



KSS 40

BATTERY-OPERATED CROSS-CUTTING SAW

- Cut depth with guide bar at 0°: 0 - 40 mm
- Cut depth with guide bar at 45°: 0 - 27 mm
- Cut depth without guide bar at 0°: 0 - 42 mm
- Slope angle: 0 - 45°
- Cut length: 300 mm
- Angular cuts: +45° - -60°
- Nominal no-load speed: 6700 1/min
- Weight: 3,6 kg
- Battery: 18 V, 99 Wh, LiHD

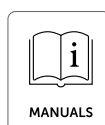

CODES

CODE	description	pcs
MA91D501	KSS 40 battery-operated cross-cutting saw	1



HOT GUN

HOT AIR GUN

- Voltage: **230 V**
- Frequency: **50/60 Hz**
- Performances: **1600 W**
- Temperature: **40-700 °C**
- Airflow (20°C): **240 l/min**
- Nozzle connection Ø: **31,5 mm**
- Protection class: **II**
- Weight: **1 kg**



CODES AND DIMENSIONS

CODE	description	pcs
1 HOTGUN(*)	professional hot air gun	1
2 HOTGUNFN40	flat 40 mm nozzle	1

(*)Nozzle not included.
Supply: hot air gun with case.



P 26 C

COMBI HAMMER

- Powerful combi hammer (percussion drilling and chiselling) with SDS-PLUS shank



CODES AND DIMENSIONS

CODE	description	weight	pcs
DUP26C	combi hammer	3,9 kg	1

SET

CODE	description	pcs
DUP26CSET	combi hammer set	1

Set = combi hammer - pointed chisel SMP1 - flat chisel FMP2 - stone drilling set 7 pcs (Ø5 - 12) SDS 7 T.





The minimum necessary to work at maximum efficiency

"Tools for timber construction" is the catalogue of carpenters' favourite tools. Tools, screwdrivers, machines and nailguns, transport and lifting systems, drill bits and cutters, timber repair solutions and specific accessories for every need.



Try them out for peak performance

rothoblaas.com



rothoblaas

Solutions for Building Technology

TARGA

INFORMATION PLATE FOR FALL PROTECTION SYSTEMS

COMPLETE

Available in 3 specific versions and in 28 different languages.

PRACTICAL

It contains all the necessary information on installation, use and maintenance.



CODES AND DIMENSIONS

CODE	description	material	pcs
TARGAxy*	information plate for fall protection systems	stainless steel (AISI 304), plastic	1
TARGAHORxy*	information plate for PATROL and H-RAIL	stainless steel (AISI 304), plastic	1
TARGAVERTxy*	information plate for VERTIGRIP	stainless steel (AISI 304), plastic	1

*xy represents the ISO 639-1 language code, see the table below for reference.

EXAMPLE:

TARGAEN	information plate for fall protection systems in EN (English)
TARGAHOREN	information plate for PATROL and H-RAIL in EN (English)
TARGAVERTEN	information plate for VERTIGRIP in EN (English)

language	
EN	Italian
DE	German
EN	English
ES	Spanish
FR	French
PT	Portuguese
RU	Russian
CS	Czech
DA	Danish
EL	Greek

language	
ET	Estonian
FI	Finnish
HR	Croatian
HU	Hungarian
IS	Icelandic
TL	Lithuanian
LV	Latvian
NL	Dutch
NO	Norwegian
PL	Polish

language	
RO	Romanian
SK	Slovak
SL	Slovenian
SV	Swedish
TR	Turkish
JA	Japanese
ZH	Chinese
AR	Arabic

GREASE

ANTI-SEIZE AND RELEASE PASTE

- The product reduces friction and prevents dirt and dust from settling on joints, ensuring that stainless steel connections run smoothly. It facilitates both assembly and disassembly of components
- GREASE complements the range of fall arrest systems by facilitating their use and improving their efficiency. It is available in two formats: 30 g and 85 g tube
- Protects stainless steel elements from wear and seizure making them extremely durable



CODES AND DIMENSIONS

CODE	content	pcs
	[g]	
GREASE30	30	1
GREASE85	85	1

TECHNICAL DATA

properties	value
Colour	white
Silicone-free	yes
Density at +20 °C (+68°F) (DIN 51757)	1,42 g/cm ³
Friction coefficient (SVR system)	0,10 - 0,13
Total friction value	0,13 μ
Thread friction value	0,11 μ
Head base friction value	0,14 μ

Store the product in a dry location at room temperature. The product in its original unopened containers remains stable for 24 months.

MANICA

SEALING SLEEVE WITH SHRINK TUBING AND CLAMP

WATERPROOF

Sleeve, heat shrink tubing and metal clamp ensure waterproofing.

EFFECTIVE

The three models with a base of slated bituminous concrete, PVC and FPO/PP make it possible to choose the most suitable base for the roofing sheath.

STRONG

The materials are weather-resistant, stabilised against UV radiation, resistant to high and low temperatures, oxidation and ageing.

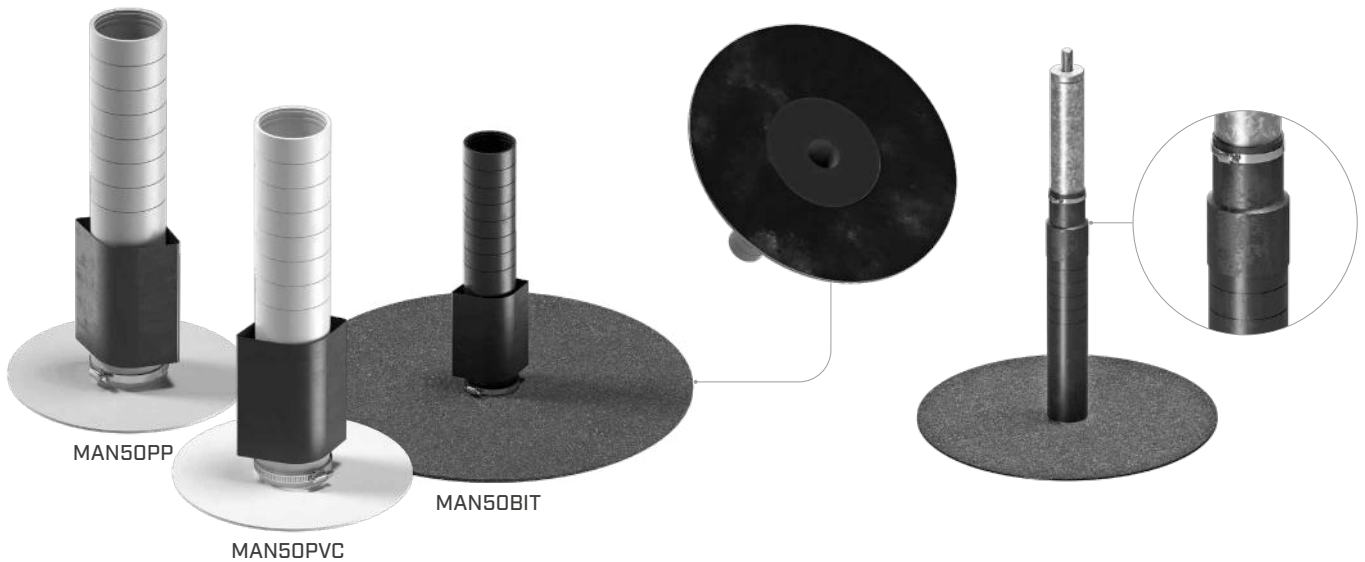

CODES AND DIMENSIONS

CODE	description	material	d ₁ [mm] [in]	d ₂ [mm] [in]	H [mm] [in]	s ₁ [mm] [in]	s ₂ [mm] [in]	pcs
MAN50BIT	sealing sleeve with shrink tubing and clamp	PVC; slated bituminous	50 1 15/16	430 16 15/16	210 8 1/4	3 1/8	4 3/16	1
MAN50PVC	sealing sleeve with shrink tubing and clamp	PVC	50 1 15/16	180 7 1/8	300 11 3/4	3 1/8	2 1/16	1
MAN50PP	sealing sleeve with shrink tubing and clamp	FPO/PP	50 1 15/16	180 7 1/8	300 11 3/4	3 1/8	2 1/16	1

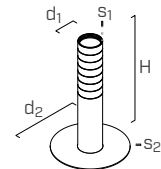

RELATED PRODUCTS



TOWER

SUPPORT FOR TIMBER,
CONCRETE AND STEEL
ROOFS

▶ page 120



TOWER A2

ANCHOR POINT FOR
TIMBER, CONCRETE AND
STEEL ROOFS

▶ page 120

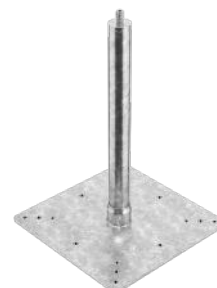

TOWER XL

SUPPORT FOR LIFELINE
ON CLT, CONCRETE AND
HOLLOW CORE CONCRETE
ROOFS

▶ page 121

MANICA ROLL

SELF-ADHESIVE LEAD AND BUTYL VERSION

CODES AND DIMENSIONS

CODE	B		s		L		colour	RAL	pcs
	[mm]	[in]	[mm]	[in]	[m]	[in]			
MANROLL1	300	11 3/4	1,5	1/16	5	197	brick red	8004	1
MANROLL2	300	11 3/4	1,5	1/16	5	197	brown	8017	1
MANROLL3	300	11 3/4	1,5	1/16	5	197	dark brown	8019	1
MANROLL4	300	11 3/4	1,5	1/16	5	197	black	9005	1
MANROLL5	300	11 3/4	1,5	1/16	5	197	graphite	7016	1

Avoid contact with skin, eyes and food. Do not produce and breathe dust.



MANICA LEAD

LEAD PROFILE WITH EPDM SLEEVE

CODES AND DIMENSIONS

CODE	s		B		L		Ø		material	pcs
	[mm]	[in]	[mm]	[in]	[mm]	[in]	[mm]	[in]		
MANEPDM	-	-	-	-	-	-	48	1.89	EPDM	1
MANLEAD	1	0.039	310	12 3/16	405	15 15/16	-	-	lead ⁽¹⁾	1

⁽¹⁾Avoid contact with skin, eyes and food. Do not produce and breathe dust. Waste classification (2014/955/EU): 17 09 04



MANICA POST

ADHESIVE SEALING SLEEVE FOR OUTDOORS

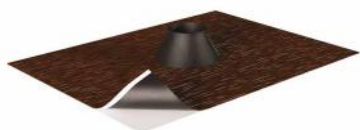

CODES AND DIMENSIONS

CODE	B		H		Ø		colour	pcs
	[mm]	[in]	[mm]	[in]	[mm]	[in]		
MANPOST1	300	11 3/4	200	8	25 / 32	1-1 1/4	brown	5
MANPOST2	300	11 3/4	200	8	42 / 55	1 5/8-2 3/16	brown	5
MANPOST3	230	9 1/16	230	9 1/16	42 / 55	1 5/8-2 3/16	aluminium	4

Waste classification (2014/955/EU): 17 09 04.



TOWER PEAK

ADAPTER FOR DOUBLE LAYER RIDGE PIECE FOR TOWER

- Accessory that allows for lifeline assembly even on closed roofing, without the need for opening and adapting to any slope
- The TOWER PEAK adaptor makes it possible to provide safety for up to four workers

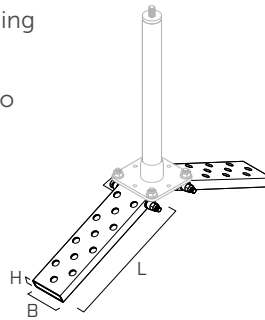

CODES AND DIMENSIONS

CODE	material	B [mm] [in]	H [mm] [in]	L [mm] [in]	pcs
TOWERPEAK	S235JR zinc plated steel	100 4	30 1 3/16	350 13 3/4	1

COMPLEMENTARY PRODUCTS

no.	CODE	description	Ø [mm]	min. dimensions GL24h beam [mm]
24	HBS	screw for timber	8	100 x 100

The values indicated are the result of experimental tests carried out under the supervision of third parties in accordance with the standard referred to. For a calculation report with minimum distances according to the relevant standard requirements, the substructure must be checked by a qualified engineer before installation.

EN 795:2012 A+C	CEN/TS 16415:2013	UNI 11578:2015 A+C
--------------------	----------------------	--------------------------



MAXIMUM NUMBER OF USERS

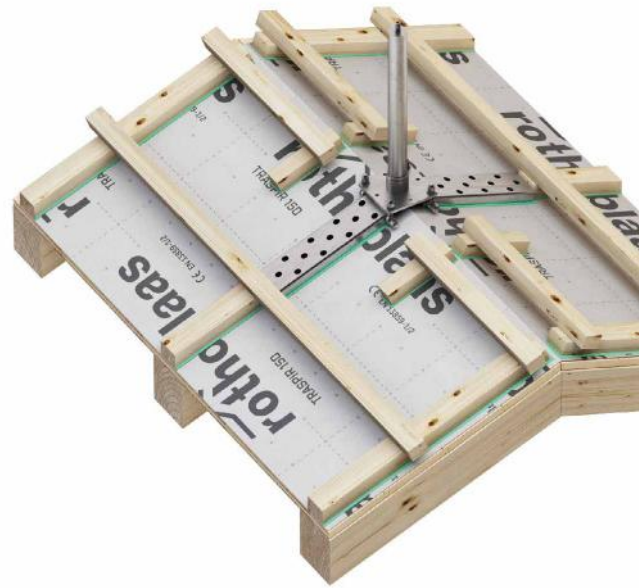

TOWER SLOPE

FASTENING GUIDE FOR TOWER ON RAFTER

- It can be positioned at any point on the roof
- Due to the range of action from 50 to 100 cm, it can cover the most common distances between beams

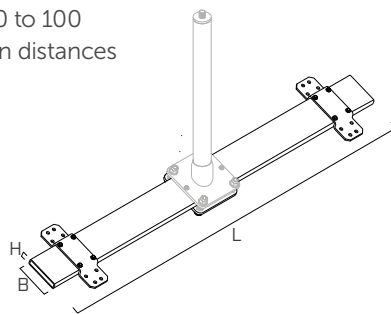

CODES AND DIMENSIONS

CODE	material	B [mm] [in]	H [mm] [in]	L [mm] [in]	pcs
TOWERSLOPE	S235JR zinc plated steel	100 4	20 13/16	1200 47 1/4	1

COMPLEMENTARY PRODUCTS

no.	CODE	description	Ø [mm]	min. dimensions GL24h beam [mm]
16	HBS	screw for timber	8	100 x 100

The values indicated are the result of experimental tests carried out under the supervision of third parties in accordance with the standard referred to. For a calculation report with minimum distances according to the relevant standard requirements, the substructure must be checked by a qualified engineer before installation.

EN 795:2012 A+C	CEN/TS 16415:2013	UNI 11578:2015 A+C
--------------------	----------------------	--------------------------



MAXIMUM NUMBER OF USERS

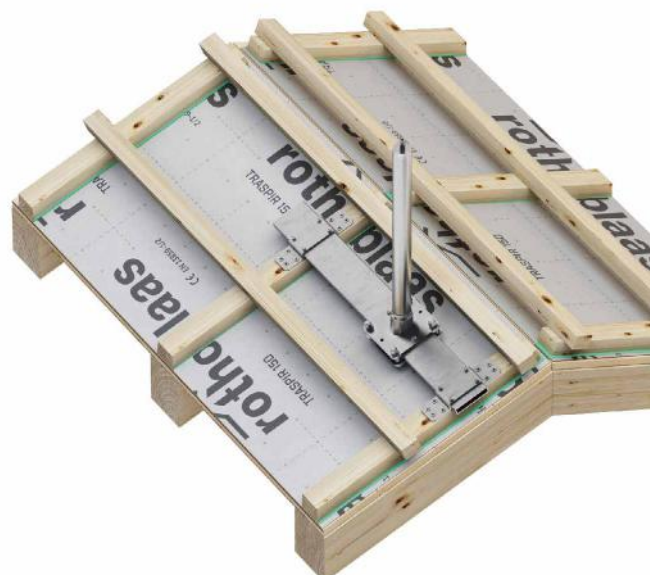

TOWLATEVO

TOWER FOR INSTALLATION ON VERTICAL STRUCTURES

- It allows the construction of lifelines on a TOWER support, even when installed on vertical structures
- It supports all required forces for a lifeline according to EN 795:2012 A+C

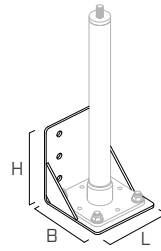

CODES AND DIMENSIONS

CODE	material	weight [kg]	B	H	L	pcs
			[mm] [in]	[mm] [in]	[mm] [in]	
TOWLATEVO	S235JR zinc plated steel	3,5	186 7 5/16	208 8 3/16	182 7 3/16	1



TOPLATE

COUNTERPLATE FOR TOWER

- Counterplate for TOWER and TOWER22 complete with nuts and washers

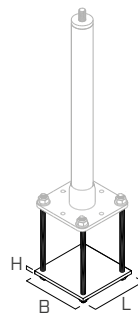

CODES AND DIMENSIONS

CODE	material	B	H	L	pcs
		[mm] [in]	[mm] [in]	[mm] [in]	
TOPLATE	S235JR zinc plated steel	150 6	8 5/16	150 6	1

COMPLEMENTARY PRODUCTS

no.	CODE	description	Ø [mm]
4	MGS	threaded rod	12
4	KOS	hexagonal head bolt	

The values indicated are the result of experimental tests carried out under the supervision of third parties in accordance with the standard referred to. For a calculation report with minimum distances according to the relevant standard requirements, the substructure must be checked by a qualified engineer before installation.

EN 795:2012
A+C

CEN/TS
18415:2013

UNI
11578:2015
A+C



MAXIMUM NUMBER
OF USERS

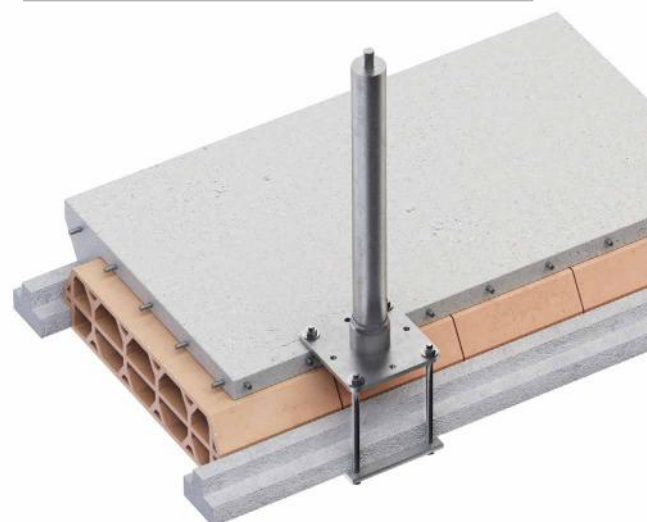

TOPLATE 2.0

COUNTERPLATE FOR TOWER/TOWER XL

- Counterplate for TOWER/TOWER XL

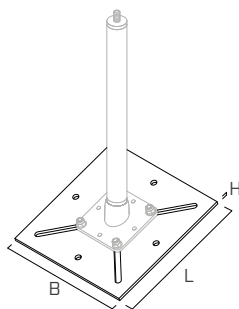

CODES AND DIMENSIONS

CODE	material	B [mm] [in]	H [mm] [in]	L [mm] [in]	pcs
TOPLATE2	S235JR zinc plated steel	350 13 3/4	8 5/16	350 13 3/4	1

COMPLEMENTARY PRODUCTS

no.	CODE	description	Ø [mm]
4	MGS	threaded rod	12
4	KOS	hexagonal head bolt	

The values indicated are the result of experimental tests carried out under the supervision of third parties in accordance with the standard referred to. For a calculation report with minimum distances according to the relevant standard requirements, the substructure must be checked by a qualified engineer before installation.

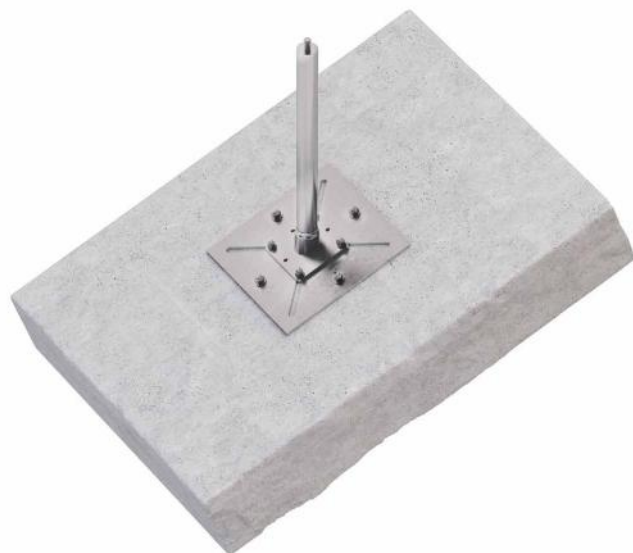

TRAPO

SUPPORT FOR TOWER XL ON TRAPEZOIDAL STEEL DECK ROOFS

- It can be assembled on trapezoidal steel decks min. thickness 0.75 mm with or without insulation layer (included fastening screws)



CODES AND DIMENSIONS

CODE	material	range [mm] [in]	pcs
TRAPO	S235JR zinc plated steel	520 - 660 20 1/2 - 26	1

The values indicated are the result of experimental tests carried out under the supervision of third parties in accordance with the standard referred to. For a calculation report with minimum distances according to the relevant standard requirements, the substructure must be checked by a qualified engineer before installation.



MULTIPLATE

UNIVERSAL COUNTERPLATE FOR HOOK, LOOP AND AOS

CODES AND DIMENSIONS

CODE	material	s [mm] [in]	B [mm] [in]	H [mm] [in]	L [mm] [in]	pcs
MULTIPLATE	S235JR zinc plated steel	6 0.236	350 13 3/4	-	130 5 1/8	1
OMEGA	S235JR zinc plated steel	8 0.315	290 11 7/16	68 2 11/16	80 3 1/8	1

COMPLEMENTARY PRODUCTS

CODE	description	Ø [mm]	pcs
MGS	threaded rod	M16	1
ULS - MUT	washer - nut	M16	1
KOS	hexagonal head bolt		



MULTIPLATE

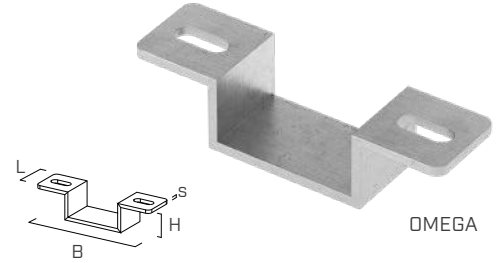

OMEGA

MULTIPLATE+HOOKEV02.0

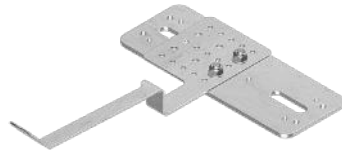

MULTIPLATE+AOS

MULTIPLATE+LOOP 90° turned

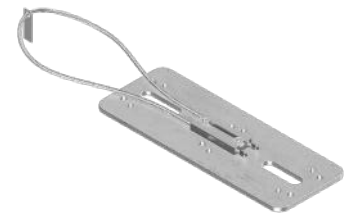

MULTIPLATE+LOOP

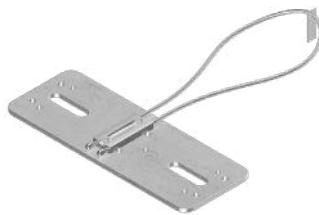

MULTIPLATE+OMEGA

MULTIPLATE+MULTIPLATE

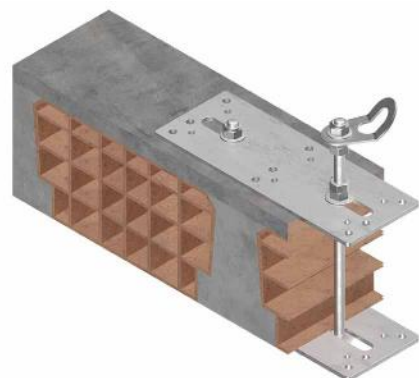

BEF TOWERXL1

TOWER XL fastening set for aerated concrete

CODE	no.	content	Ø [mm]	pcs
BEFTOWERXL1	8	hexagonal head bolt	M10	1
	8	heavy anchors	M10	
	8	washers	-	



BEF MULTI

LOOP fastening set for MULTIPLATE

CODE	no.	content	Ø [mm] [in]	L [mm] [in]	pcs
BEFMULTI	2	countersunk head bolts	8 5/16	30 1 3/16	1
	2	M8 self-locking nut	-	-	



BEF SLIM

fastening set for SLIM

CODE	no.	content	Ø [mm]	pcs
BEFSLIM1	2	washers	M10	1
	2	hexagonal nut	M10	
	1	threaded rod (L = 200 mm)	M10	
	1	self-locking nut	M10	
	1	GEKA (DEXT = 50 mm)	-	
BEFSLIM2	3	washers	M10	1
	2	hexagonal nut	M10	
	1	washer	M12	
	1	threaded rod (L = 200 mm)	M10	
	2	self-blocking nut	M10	
	1	round head bolt	M10	
1	"L" plate	-		
1	GEKA (DEXT = 50 mm)	-		



BEFSLIM1



BEFSLIM2

BEF TOWER

fastening set for TOWER

CODE	no.	content	Ø [mm] [in]	L [mm] [in]	pcs
BEF201VGS	8	VGS screws	9 0.36	160 6 1/4	1
	4	washers	-	-	
BEF202VGS	8	VGS screws	9 0.36	200 8	1
	4	washers	-	-	

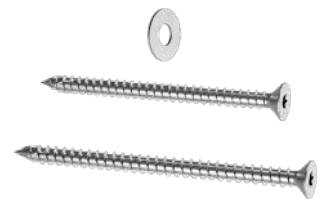

BEF PLATE

TOWER - TOWER22 fastening set for TOPLATE 2.0

CODE	no.	content	Ø [mm]	pcs
BEFPLATE	4	self-blocking nut	M12	1
	4	hexagonal head bolts 35 mm	M12	
	4	washers	-	

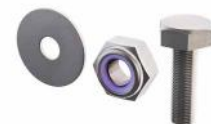

BEF KITE





fastening set for KITE

CODE	no.	content	d ₁ [mm] [in]	L [mm] [in]	pcs
BEFKITE	1	VGS screw	11 0.43	100 4	1
	2	HBS screws	8 0.31	100 4	

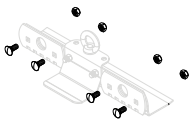

SPARE PARTS

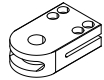
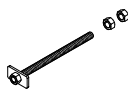
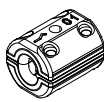
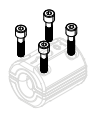
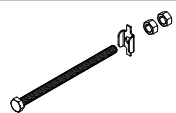
CODES AND DIMENSIONS

CODE	description	material	pcs	
SPSIANK	spare for SIANK kit with 4 bolts and self-locking nuts	A2-70	4	
SPVERTSCREWS	spare for VERTIGRIP kit with 4 bolts and nuts for counterplate	A2-70	4	
SPSPEARSCREWS	spare for SPEAR kit with 4 screws for SPEAR and VERTSPEAR clamp	A2-70	4	
SPEARCLAMP	spare for SPEAR clamp for SPEAR and VERTSPEAR	EN AW 6082 T6 aluminium	1	
SPSPEARBAR	spare for SPEAR threaded rod and nuts for SPEAR	A2-70 AISI 304 stainless steel grade 1.4301	1	
SPEVOCLAMP	spare for SPEAREVO SPEAREVO clamp	AISI 304 stainless steel grade 1.4301	1	
SPEVOSCREWS	spare for SPEAREVO kit with 4 screws for SPEAREVO clamp	A2-70	4	
SPEVOBAR	spare for SPEAREVO bolt kit M12 x 200 plate and nuts	A2-70 AISI 304 stainless steel grade 1.4301	1	
EPDM253	single-sided EPDM tape 25 mm x 20 m, thickness 3 mm	EPDM	1	
RIV6320	set of 33 rivets 6,3 x 20,2 mm with EPDM washer	aluminium	1	
MMSW5525A2S17	MMS self-tapping screws A2 5,5 x 25 mm with washer	AISI 304 stainless steel grade 1.4301 EPDM	17	
MMS5525A2	MMS self-tapping screws A2 5,5 x 25 mm without washer	AISI 304 stainless steel grade 1.4301	50	

SKR | SKS | SKP

SCREW-IN ANCHOR FOR CONCRETE CE1

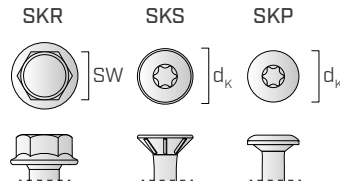
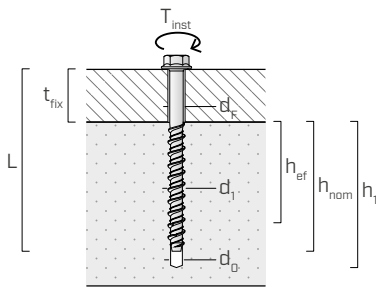

- d_1 external diameter of anchor
- L anchor length
- t_{fix} maximum fastening thickness
- h_1 minimum hole depth
- h_{nom} nominal anchoring depth
- h_{ef} effective anchoring depth
- d_0 hole diameter in the concrete support
- d_f maximum hole diameter in the element to be fastened
- SW wrench size
- d_K head diameter
- T_{inst} tightening torque

CODES AND DIMENSIONS

SKR - hexagonal head with mock washer

CODE	d_1 [mm]	L [mm]	t_{fix} [mm]	h_1 [mm]	h_{nom} [mm]	h_{ef} [mm]	d_0 [mm]	d_f [mm]	SW [mm]	$T_{inst}^{(*)}$ [Nm]	pcs
SKR8100	8	100	40	75	60	48	6	9	10	210	50
SKR1080		80	10	85	70	56	8	12	13	210	50
SKR10100	10	100	30	85	70	56	8	12	13	210	25
SKR10120		120	50	85	70	56	8	12	13	210	25
SKR1290		90	10	100	80	64	10	14	15	330	25
SKR12110		110	30	100	80	64	10	14	15	330	25
SKR12150		150	70	100	80	64	10	14	15	330	25
SKR12210	12	210	130	100	80	64	10	14	15	330	20
SKR12250		250	170	100	80	64	10	14	15	330	15
SKR12290		290	210	100	80	64	10	14	15	330	15
SKR16130	16	130	20	140	110	85	14	18	21	330	10

(*)Maximum pulse screw gun power setting values (see installation sequence).

SKS - countersunk head

CODE	d_1 [mm]	L [mm]	t_{fix} [mm]	h_1 [mm]	h_{nom} [mm]	h_{ef} [mm]	d_0 [mm]	d_f [mm]	d_K [mm]	TX	pcs
SKS660	6	60	10	55	50	38	5	7	11	TX30	100
SKS880		80	20	75	60	48	6	9	14	TX30	50
SKS8100	8	100	40	75	60	48	6	9	14	TX30	50
SKS10100	10	100	30	85	70	56	8	12	20	TX40	50

SKP - convex head

CODE	d_1 [mm]	L [mm]	t_{fix} [mm]	h_1 [mm]	h_{nom} [mm]	h_{ef} [mm]	d_0 [mm]	d_f [mm]	d_K [mm]	TX	pcs
SKP680		80	30	55	50	38	5	7	12	TX30	50
SKP6100	6	100	50	55	50	38	5	7	12	TX30	50

SKR EVO | SKS EVO

SCREW-IN ANCHOR FOR CONCRETE

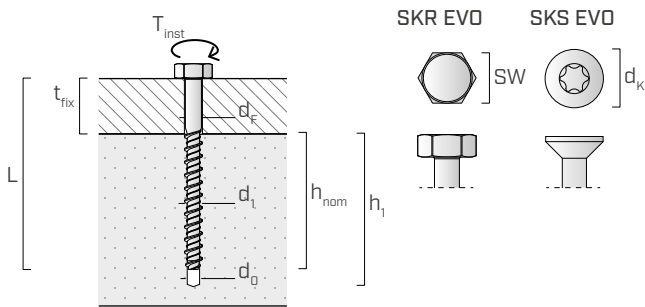

- d_1 external diameter of anchor
- L anchor length
- t_{fix} maximum fastening thickness
- h_1 minimum hole depth
- h_{nom} nominal anchoring depth
- d_0 hole diameter in the concrete support
- d_f maximum hole diameter in the element to be fastened
- SW wrench size
- d_K head diameter
- T_{inst} tightening torque



SKR EVO

SKS EVO

CODES AND DIMENSIONS

SKR EVO - hexagonal head

CODE	d_1 [mm]	L [mm]	t_{fix} [mm]	$h_{1,min}$ [mm]	h_{nom} [mm]	d_0 [mm]	$d_{f\ timber}$ [mm]	$d_{f\ steel}$ [mm]	SW [mm]	T_{inst} [Nm]	pcs
SKREVO7560	7,5	60	10	60	50	6	8	8-10	13	15	50
SKREVO7580		80	30	60	50	6	8	8-10	13	15	50
SKREVO75100		100	20	90	80	6	8	8-10	13	15	50
SKREVO1080	10	80	30	65	50	8	10	10-12	16	25	50
SKREVO10100		100	20	95	80	8	10	10-12	16	25	25
SKREVO10120		120	40	95	80	8	10	10-12	16	25	25
SKREVO10140		140	60	95	80	8	10	10-12	16	25	25
SKREVO10160		160	80	95	80	8	10	10-12	16	25	25
SKREVO12100		100	20	100	80	10	12	12-14	18	50	25
SKREVO12120	120	40	100	80	10	12	12-14	18	50	25	
SKREVO12140	140	60	100	80	10	12	12-14	18	50	25	
SKREVO12160	12	160	80	100	80	10	12	12-14	18	50	25
SKREVO12200		200	120	100	80	10	12	12-14	18	50	25
SKREVO12240		240	160	100	80	10	12	12-14	18	50	25
SKREVO12280		280	200	100	80	10	12	12-14	18	50	25
SKREVO12320		320	240	100	80	10	12	12-14	18	50	25
SKREVO12400	400	320	100	80	10	12	12-14	18	50	25	

SKS EVO - countersunk head

CODE	d_1 [mm]	L [mm]	t_{fix} [mm]	$h_{1,min}$ [mm]	h_{nom} [mm]	d_0 [mm]	$d_{f\ timber}$ [mm]	d_k [mm]	TX	T_{inst} [Nm]	pcs
SKSEVO7560	7,5	60	10	60	50	6	8	13	TX40	-	50
SKSEVO7580		80	30	60	50	6	8	13	TX40	-	50
SKSEVO75100		100	20	90	80	6	8	13	TX40	-	50
SKSEVO75120		120	40	90	80	6	8	13	TX40	-	50
SKSEVO75140		140	60	90	80	6	8	13	TX40	-	50
SKSEVO75160		160	80	90	80	6	8	13	TX40	-	50

HEAVY DUTY EXPANSION ANCHOR CE1

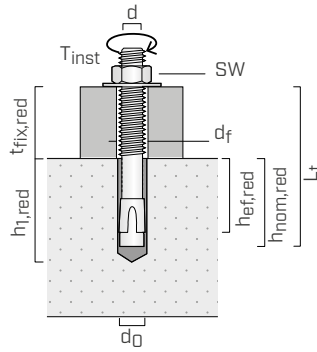
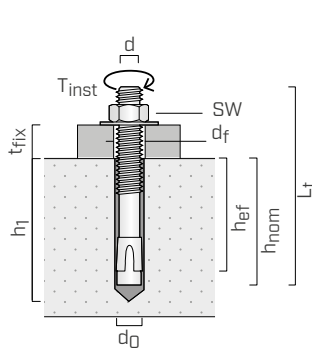

- d** anchor diameter
- d₀** hole diameter in the concrete support
- L_t** anchor length
- t_{fix}** maximum fastening thickness
- h₁** minimum hole depth
- h_{nom}** nominal anchoring depth
- h_{ef}** effective anchoring depth
- d_f** maximum hole diameter in the element to be fastened
- SW** wrench size
- T_{inst}** tightening torque



CODES AND DIMENSIONS

CODE	d = d ₀ [mm]	L _t [mm]	t _{fix} t _{fix,red} [mm]	h ₁ h _{1,red} [mm]	h _{nom} h _{nom,red} [mm]	h _{ef} h _{ef,red} [mm]	d _f [mm]	SW [mm]	T _{inst} [Nm]	pcs
ABE870	M8	70	5	65	55	48	9	13	20	100
ABE895	M8	95	25	65	55	48	9	13	20	100
ABE8115	M8	115	45	65	55	48	9	13	20	100
ABE10110	M10	110	30 50	80 60	70 50	60 40	12	17	45	50
ABE10140	M10	140	60 80	80 60	70 50	60 40	12	17	45	50
ABE12110	M12	110	15	90	81	70	14	19	60	50
ABE12125	M12	125	30	90	81	70	14	19	60	50
ABE12145	M12	145	50	90	81	70	14	19	60	50
ABE12185	M12	185	90	90	81	70	14	19	60	50
ABE16145	M16	145	30	110	98	80	18	24	80	25

HEAVY DUTY EXPANSION ANCHOR CE1

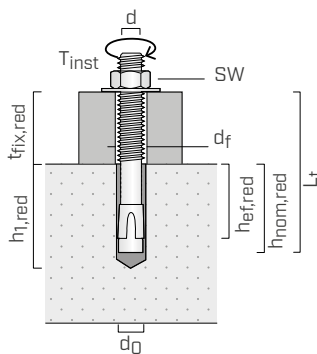
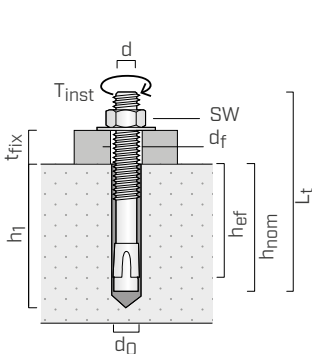

- d** anchor diameter
- d₀** hole diameter in the concrete support
- L_t** anchor length
- t_{fix}** maximum fastening thickness
- h₁** minimum hole depth
- h_{nom}** nominal anchoring depth
- h_{ef}** effective anchoring depth
- d_f** maximum hole diameter in the element to be fastened
- SW** wrench size
- T_{inst}** tightening torque



CODES AND DIMENSIONS

CODE	d = d ₀ [mm]	L _t [mm]	t _{fix} t _{fix,red} [mm]	h ₁ h _{1,red} [mm]	h _{nom} h _{nom,red} [mm]	h _{ef} h _{ef,red} [mm]	d _f [mm]	SW [mm]	T _{inst} [Nm]	pcs
ABE895A4	M8	95	25	65	55	48	9	13	20	100
ABE8115A4	M8	115	45	65	55	48	9	13	20	100
ABE1095A4	M10	95	15 35	80 60	70 50	60 40	12	17	45	100
ABE10140A4	M10	140	60 80	80 60	70 50	60 40	12	17	45	50
ABE12110A4	M12	110	15	90	81	70	14	19	60	50
ABE16145A4	M16	145	30	110	98	80	18	24	80	25

HEAVY DUTY EXPANSION ANCHOR CE1

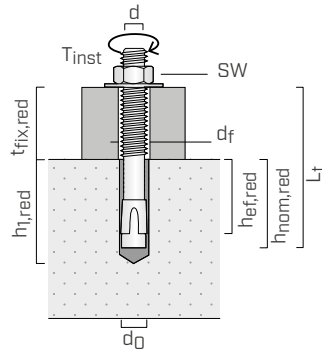
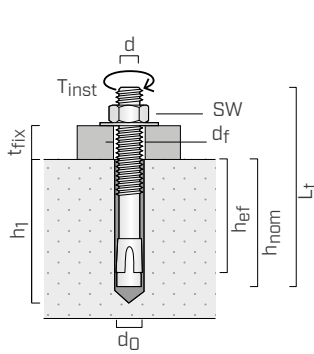

- d** anchor diameter
- d₀** hole diameter in the concrete support
- L_t** anchor length
- t_{fix}** maximum fastening thickness
- h₁** minimum hole depth
- h_{nom}** nominal anchoring depth
- h_{ef}** effective anchoring depth
- d_f** maximum hole diameter in the element to be fastened
- SW** wrench size
- T_{inst}** tightening torque



Zn
ELECTRO
PLATED

CODES AND DIMENSIONS

CODE	d = d ₀ [mm]	L _t [mm]	t _{fix} t _{fix,red} [mm]	h ₁ h _{1,red} [mm]	h _{nom} h _{nom,red} [mm]	h _{ef} h _{ef,red} [mm]	d _f [mm]	SW [mm]	T _{inst} [Nm]	pcs
AB110115	M10	115	35	75	68	60	12	17	40	25
AB110135	M10	135	55	75	68	60	12	17	40	25
AB112100	M12	100	4	85	80	70	14	19	60	25
AB112120	M12	120	24	85	80	70	14	19	60	25
AB112150	M12	150	54	85	80	70	14	19	60	25
AB112180	M12	180	84	85	80	70	14	19	60	25
AB116145	M16	145	25 45	110 90	97 77	85 65	18	24	90	10

VIN-FIX

VINYL ESTER CHEMICAL ANCHOR WITHOUT STYRENE



CODES AND SIZES

CODE	format	pcs
	[mL]	
FIX300	300	12
FIX420	420	12

Expiry from date of manufacturing: 12 months for 300 mL, 18 months for 420 mL.
Storage temperature between +5 and +25° C.

HYB-FIX

HIGH-PERFORMANCE HYBRID CHEMICAL ANCHOR



CODES AND SIZES

CODE	format	pcs
	[mL]	
HYB280	280	12
HYB420	420	12

Expiry from date of manufacturing: 18 months.
Storage temperature between +5 and +25° C.

EPO-FIX

HIGH-PERFORMANCE EPOXY CHEMICAL ANCHOR



CODES AND SIZES

CODE	format	pcs
	[mL]	
EPO585	585	12

Expiry from date of manufacturing: 24 months.
Storage temperature between +5 and +35° C.

5.8 AND 8.8 STEEL CLASS THREADED ROD FOR CHEMICAL ANCHORS

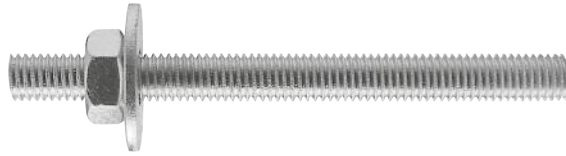

CODES AND DIMENSIONS

5.8 steel class threaded rod

CODE	d [mm]	L _t [mm]	d ₀ [mm]	d _f [mm]	pcs
INA588110	M8	110	10	≤ 9	25
INA5810105	M10	105	12	≤ 12	25
INA5810140		140	12	≤ 12	25
INA5812140	M12	140	14	≤ 14	25
INA5812195		195	14	≤ 14	25
INA5816160	M16	160	18	≤ 18	15
INA5816195		195	18	≤ 18	15
INA5816245	M20	245	18	≤ 18	15
INA5820245		245	24	≤ 22	10
INA5820330	M24	330	24	≤ 22	10
INA5824330		330	28	≤ 26	5
INA5827330	M27	330	32	≤ 30	5

d₀ = hole diameter in the support / d_f = hole diameter in the element to be fastened

8.8 steel class threaded rod

CODE	d [mm]	L _t [mm]	d ₀ [mm]	d _f [mm]	pcs
INA8812140	M12	140	14	≤ 14	25
INA8812195		195	14	≤ 14	25
INA8812245	M16	245	14	≤ 14	25
INA8816160		160	18	≤ 18	15
INA8816195	M20	195	18	≤ 18	15
INA8816245		245	18	≤ 18	15
INA8816330	M24	330	18	≤ 18	15
INA8820245		245	24	≤ 22	10
INA8820330	M27	330	24	≤ 22	10
INA8820495		495	24	≤ 22	10
INA8824330	M24	330	28	≤ 26	5
INA8824495		495	28	≤ 26	5
INA8827330	M27	330	32	≤ 30	5
INA8827495		495	32	≤ 30	5

d₀ = hole diameter in the support / d_f = hole diameter in the element to be fastened

IHP - IHM

BUSHINGS FOR PERFORATED MATERIALS

CODES AND DIMENSIONS

IHP - plastic net

CODE	d ₀ [mm]	L [mm]	rod [mm]	pcs
IHP1685	16	85	M10 (M8)	10
IHP16130	16	130	M10 (M8)	10
IHP2085	20	85	M12	10

IHM - metal net

CODE	d ₀ [mm]	L [mm]	rod [mm]	pcs
IHM121000	12	1000	M8	50
IHM161000	16	1000	M8/M10	50
IHM221000	22	1000	M12/M16	25



IR BUSHING WITH INTERNAL METRIC THREAD



- 5.8 grade zinc plated steel
- It makes it possible to reach the maximum tensile performance of the chemical anchor system
- Certified installation with the chemical anchor HYB-FIX and EPO-FIX

CODE	d ₂ [mm]	d [mm]	d ₀ [mm]	L [mm]	d _f [mm]	pcs
IRM880	M8	12	14	80	≤ 9	10
IRM1080	M10	16	18	80	≤ 12	10
IRM12125	M12	20	24	125	≤ 14	10
IRM16170	M16	24	28	170	≤ 18	5

d₂ = internal threaded rod diameter

d₀ = hole diameter in the concrete support

d = diameter of the element anchored on concrete

d_f = diameter hole in the element to be fastened

PLU INJECTION NOZZLE



- For filling the hole without air bubbles
- It is used for overhead applications of the chemical anchor
- EPDM material

CODE	rod [mm]	internal thread bushing [mm]	d ₀ [mm]	pcs
PL14	M12	-	14	20
PL18	M16	IR-M10	18	20
PL24	M20	IR-M12	24	20
PL28	M24	IR-M16	28	20
PL32	M27	-	32	20
PL35	M30	-	35	20

ADDITIONAL PRODUCTS - ACCESSORIES

CODE	description	pcs
STINGEXT	extension tube for nozzle	1

FILL FILLING WASHER



- It makes it possible to fill the annular space as a final step to set the anchor system
- It can be used to drill larger holes in the item to be attached
- Increased shear resistance under seismic load

CODE	rod [mm]	d _{INT} [mm]	d _{EXT} [mm]	s [mm]	pcs
FILL8	M8	9	23	5	10
FILL10	M10	12	26	5	10
FILL12	M12	14	28	5	10
FILL16	M16	17	34	5	5
FILL20	M20	21	41	5	5
FILL24	M24	25	48	6	5

ADDITIONAL PRODUCTS - ACCESSORIES

CODE	description	pcs
STINGRED	nozzle tip reducer	1



XEPOX®

TWO COMPONENTS EPOXY ADHESIVE



EN 1504-4

CODE	description	content [mL]	pcs
XEPOXF400 ⁽¹⁾	F - fluid	400	1

⁽¹⁾ 1 STINGXP mixing nozzle included per XEPOXF400 cartridge

Component A classification: Eye Irrit. 2; Skin Irrit. 2; Skin Sens. 1A; Aquatic Chronic 2; Component classification B: Repr. 1B; Acute Tox. 4; STOT RE 2; Skin Corr. 1B; Eye Dam. 1; Skin Sens. 1A.

CODE	description	content [mL]	pcs
XEPOXD400 ⁽¹⁾	D - dense	400	1

⁽¹⁾ 1 STINGXP mixing nozzle included per XEPOXD400 cartridge

Component A classification: Eye Irrit. 2; Skin Irrit. 2; Skin Sens. 1; Aquatic Chronic 2; Component classification B: Repr. 1B; Acute Tox. 4; Skin Corr. 1B; Eye Dam. 1; Skin Sens. 1; Aquatic Chronic 3.

MAMMOTH DOUBLE

SPECIAL GUN FOR TWO-COMPONENT ADHESIVE

- Also suitable for XEPOX line cartridges, such as XEPOXF400 and XEPOXD400



CODE	description	pcs
MAMDB	for double cartridge	1

DISC FLAT

REMOVABLE CONCEALED CONNECTOR



DISCF55

DISCF80

DISCF120



ETA-19/0706



DESIGN REGISTERED

S235 Fe/Zn5c

CODE	D [mm]	s [mm]	M [mm]	n _{45°} - Ø	n _{0°} - Ø	pcs
DISCF55	55	10	12	8 - Ø5	2 - Ø5	16
DISCF80	80	15	16	8 - Ø7	2 - Ø7	8
DISCF120	120	15	20	16 - Ø7	2 - Ø7	4

Screws not included in the box.

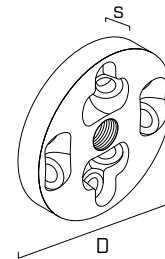

RELATED PRODUCTS

LBS - round head screw for plates

d ₁ [mm]	CODE	L [mm]	b [mm]	pcs
5 TX 20	LBS525	25	21	500
	LBS540	40	36	500
	LBS550	50	46	200
	LBS560	60	56	200
	LBS570	70	66	200
7 TX 30	LBS760	60	55	100
	LBS780	80	75	100
	LBS7100	100	95	100

LBS EVO - round head screw for plates

d ₁ [mm]	CODE	L [mm]	b [mm]	pcs
5 TX 20	LBSEVO540	40	36	500
	LBSEVO550	50	46	200
	LBSEVO560	60	56	200
	LBSEVO570	70	66	200
7 TX 30	LBSEVO780	80	75	100
	LBSEVO7100	100	95	100

HBS

COUNTERSUNK SCREW



d ₁ [mm]	CODE	L [mm]	b [mm]	A [mm]	pcs
8 TX 40	HBS880	80	52	28	100
	HBS8100	100	52	48	100
	HBS8120	120	60	60	100
	HBS8140	140	60	80	100
	HBS8160	160	80	80	100
	HBS8180	180	80	100	100
	HBS8200	200	80	120	100
	HBS8220	220	80	140	100
	HBS8240	240	80	160	100
	HBS8260	260	80	180	100
	HBS8280	280	80	200	100
	HBS8300	300	100	200	100
	HBS8320	320	100	220	100
	HBS8340	340	100	240	100
	HBS8360	360	100	260	100
	HBS8380	380	100	280	100
	HBS8400	400	100	300	100
	HBS8440	440	100	340	100
	HBS8480	480	100	380	100
	HBS8520	520	100	420	100
HBS8560	560	100	460	100	
HBS8580	580	100	480	100	
HBS8600	600	100	500	100	

HBS EVO

COUNTERSUNK SCREW



d ₁ [mm]	CODE	L [mm]	b [mm]	A [mm]	pcs
8 TX 40	HBSEVO8100	100	52	48	100
	HBSEVO8120	120	60	60	100
	HBSEVO8140	140	60	80	100
	HBSEVO8160	160	80	80	100
	HBSEVO8180	180	80	100	100
	HBSEVO8200	200	80	120	100
	HBSEVO8220	220	80	140	100
	HBSEVO8240	240	80	160	100
	HBSEVO8260	260	80	180	100
	HBSEVO8280	280	80	200	100
	HBSEVO8300	300	100	200	100
	HBSEVO8320	320	100	220	100

HBS EVO C5

COUNTERSUNK SCREW



d ₁ [mm]	CODE	L [mm]	b [mm]	A [mm]	pcs
8 TX 40	HBSEVO8100C5	100	52	48	100
	HBSEVO8120C5	120	60	60	100
	HBSEVO8140C5	140	60	80	100
	HBSEVO8160C5	160	80	80	100
	HBSEVO8180C5	180	80	100	100
	HBSEVO8200C5	200	80	120	100
	HBSEVO8220C5	220	80	140	100
	HBSEVO8240C5	240	80	160	100
	HBSEVO8280C5	280	80	200	100
	HBSEVO8320C5	320	100	220	100

**For more details
on connectors,
browse our
screws
catalogue**



Geometry,
minimum distances
and structural values

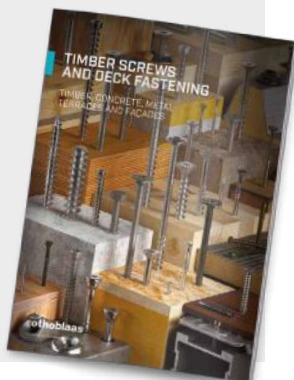

TBS

FLANGE HEAD SCREW



d ₁ [mm]	d _k [mm]	CODE	L [mm]	b [mm]	A [mm]	pcs		
6 TX 30	15,5	TBS660	60	40	20	100		
		TBS670	70	40	30	100		
		TBS680	80	50	30	100		
		TBS690	90	50	40	100		
		TBS6100	100	60	40	100		
		TBS6120	120	75	45	100		
		TBS6140	140	75	65	100		
		TBS6160	160	75	85	100		
		TBS6180	180	75	105	100		
		TBS6200	200	75	125	100		
		TBS6220	220	100	120	100		
		TBS6240	240	100	140	100		
		TBS6260	260	100	160	100		
		TBS6280	280	100	180	100		
		TBS6300	300	100	200	100		
		TBS6320	320	100	220	100		
		TBS6360	360	100	260	100		
		TBS6400	400	100	300	100		
		8 TX 40	19,0	TBS840	40	32	8	100
				TBS860	60	52	8	100
TBS880	80			52	28	50		
TBS8100	100			52	48	50		
TBS8120	120			80	40	50		
TBS8140	140			80	60	50		
TBS8160	160			100	60	50		
TBS8180	180			100	80	50		
TBS8200	200			100	100	50		
TBS8220	220			100	120	50		
TBS8240	240			100	140	50		
TBS8260	260			100	160	50		
TBS8280	280			100	180	50		
TBS8300	300			100	200	50		
TBS8320	320			100	220	50		
TBS8340	340			100	240	50		
TBS8360	360			100	260	50		
TBS8380	380			100	280	50		
TBS8400	400			100	300	50		
TBS8440	440			100	340	50		
TBS8480	480	100	380	50				
TBS8520	520	100	420	50				
TBS8560	560	100	460	50				
TBS8580	580	100	480	50				
TBS8600	600	100	500	50				

TBS EVO

FLANGE HEAD SCREW



d ₁ [mm]	d _k [mm]	CODE	L [mm]	b [mm]	A [mm]	pcs
6 TX 30	15,5	TBSEVO660	60	40	20	100
		TBSEVO680	80	50	30	100
		TBSEVO6100	100	60	40	100
		TBSEVO6120	120	75	45	100
		TBSEVO6140	140	75	65	100
		TBSEVO6160	160	75	85	100
		TBSEVO6180	180	75	105	100
		TBSEVO6200	200	75	125	100
		TBSEVO8100	100	52	48	50
		TBSEVO8120	120	80	40	50
8 TX 40	19,0	TBSEVO8140	140	80	60	50
		TBSEVO8160	160	100	60	50
		TBSEVO8180	180	100	80	50
		TBSEVO8200	200	100	100	50
		TBSEVO8220	220	100	120	50
		TBSEVO8240	240	100	140	50
		TBSEVO8280	280	100	180	50
		TBSEVO8320	320	100	220	50
		TBSEVO8360	360	100	260	50
		TBSEVO8400	400	100	300	50

TBS EVO C5

FLANGE HEAD SCREW



d ₁ [mm]	d _k [mm]	CODE	L [mm]	b [mm]	A [mm]	pcs
6 TX 30	15,5	TBSEVO660C5	60	40	20	100
		TBSEVO680C5	80	50	30	100
		TBSEVO6100C5	100	60	40	100
		TBSEVO6120C5	120	75	45	100
		TBSEVO6140C5	140	75	65	100
		TBSEVO6160C5	160	75	85	100
		TBSEVO6180C5	180	75	105	100
		TBSEVO6200C5	200	75	125	100
		TBSEVO8100C5	100	52	48	50
		TBSEVO8120C5	120	80	40	50
8 TX 40	19,0	TBSEVO8140C5	140	80	60	50
		TBSEVO8160C5	160	100	60	50
		TBSEVO8180C5	180	100	80	50
		TBSEVO8200C5	200	100	100	50
		TBSEVO8220C5	220	100	120	50
		TBSEVO8240C5	240	100	140	50

VGS



FULLY THREADED SCREW WITH COUNTERSUNK OR HEXAGONAL HEAD

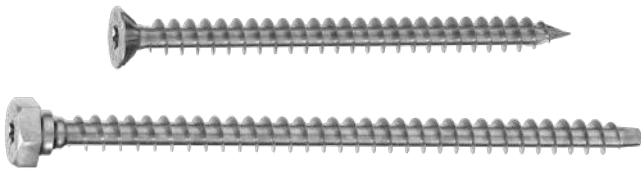

d ₁ [mm]	CODE	L [mm]	b [mm]	pcs
9 TX 40	VGS9100	100	90	25
	VGS9120	120	110	25
	VGS9140	140	130	25
	VGS9160	160	150	25
	VGS9180	180	170	25
	VGS9200	200	190	25
	VGS9220	220	210	25
	VGS9240	240	230	25
	VGS9260	260	250	25
	VGS9280	280	270	25
	VGS9300	300	290	25
	VGS9320	320	310	25
	VGS9340	340	330	25
	VGS9360	360	350	25
	VGS9380	380	370	25
	VGS9400	400	390	25
11 TX 50	VGS9440	440	430	25
	VGS9480	480	470	25
	VGS9520	520	510	25
	VGS9560	560	550	25
	VGS9600	600	590	25
	VGS1180	80	70	25
	VGS11100	100	90	25
	VGS11125	125	115	25
	VGS11150	150	140	25
	VGS11175	175	165	25
11 TX 50	VGS11200	200	190	25
	VGS11225	225	215	25
	VGS11250	250	240	25
	VGS11275	275	265	25
	VGS11300	300	290	25
	VGS11325	325	315	25
	VGS11350	350	340	25
	VGS11375	375	365	25
	VGS11400	400	390	25
	VGS11425	425	415	25
11 TX 50	VGS11450	450	440	25
	VGS11475	475	465	25
	VGS11500	500	490	25
	VGS11525	525	515	25
	VGS11550	550	540	25
	VGS11575	575	565	25
VGS11600	600	590	25	

d ₁ [mm]	CODE	L [mm]	b [mm]	pcs
11 SW 17 TX 50	VGS11650	650	630	25
	VGS11700	700	680	25
	VGS11750	750	680	25
	VGS11800	800	780	25
	VGS11850	850	830	25
	VGS11900	900	880	25
	VGS11950	950	930	25
	VGS111000	1000	980	25
13 TX 50	VGS1380	80	70	25
	VGS13100	100	90	25
	VGS13150	150	140	25
	VGS13200	200	190	25
	VGS13250	250	240	25
	VGS13300	300	280	25
	VGS13350	350	330	25
	VGS13400	400	380	25
	VGS13450	450	430	25
	VGS13500	500	480	25
13 SW 19 TX 50	VGS13550	550	530	25
	VGS13600	600	580	25
	VGS13650	650	630	25
	VGS13700	700	680	25
	VGS13750	750	730	25
	VGS13800	800	780	25
	VGS13850	850	830	25
	VGS13900	900	880	25
	VGS13950	950	930	25
	VGS131000	1000	980	25
13 TX 50	VGS131100	1100	1080	25
	VGS131200	1200	1180	25
	VGS131300	1300	1280	25
	VGS131400	1400	1380	25
	VGS131500	1500	1480	25

VGS EVO C5



FULL THREAD CONNECTOR WITH COUNTERSUNK HEAD



d ₁ [mm]	CODE	L [mm]	b [mm]	pcs
9 TX 40	VGSEVO9200C5	200	190	25
	VGSEVO9240C5	240	230	25
	VGSEVO9280C5	280	270	25
	VGSEVO9320C5	320	310	25
	VGSEVO9360C5	360	350	25

VGS EVO

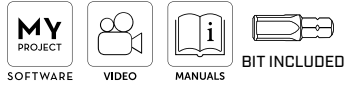

FULLY THREADED SCREW WITH
COUNTERSUNK OR HEXAGONAL HEAD

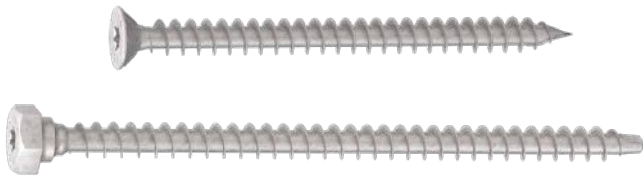

ETA-11/0030



UKTA-0836
22/6195



ESR-4645



ELC-4645



d ₁ [mm]	CODE	L [mm]	b [mm]	pcs
9 TX 40	VGSEVO9120	120	110	25
	VGSEVO9160	160	150	25
	VGSEVO9200	200	190	25
	VGSEVO9240	240	230	25
	VGSEVO9280	280	270	25
	VGSEVO9320	320	310	25
11 TX 50	VGSEVO9360	360	350	25
	VGSEVO11100	100	90	25
	VGSEVO11150	150	140	25
	VGSEVO11200	200	190	25
	VGSEVO11250	250	240	25
	VGSEVO11300	300	290	25
13 TX 50	VGSEVO11350	350	340	25
	VGSEVO11400	400	390	25
	VGSEVO11500	500	490	25
	VGSEVO11600	600	590	25
	VGSEVO13200	200	190	25
13 TX 50	VGSEVO13300	300	280	25
	VGSEVO13400	400	380	25
	VGSEVO13500	500	480	25
13 SW 19 TX 50	VGSEVO13600	600	580	25
	VGSEVO13700	700	680	25
	VGSEVO13800	800	780	25

MTS A2 | AISI304

SCREWS FOR METAL SHEET



A2
AISI 304

d ₁ [mm]	CODE	SW	d _{UK} [mm]	L [mm]	b [mm]	A [mm]	pcs
6 SW 8	MTS680	SW 8	12,5	80	58	20÷40	100
	MTS6100	SW 8	12,5	100	58	40÷60	100
	MTS6120	SW 8	12,5	120	58	60÷80	100

WBAZ

STAINLESS STEEL WASHER WITH
SEALING GASKET



A2
AISI 304

EPDM

CODE	screw [mm]	D ₂ [mm]	H [mm]	D ₁ [mm]	pcs
WBAZ25A2	6,0 - 6,5	25	15	6,5	100

HUS

TURNED WASHER



ETA-11/0030



UKTA-0836
22/6195



ESR-4645



ELC-4645



CODE	d _{HBS} [mm]	d _{VGS} [mm]	pcs
HUS10	10	11	50

HBS PLATE



PAN HEAD SCREW FOR PLATES



d ₁ [mm]	CODE	L [mm]	b [mm]	A _p [mm]	pcs
10 TX 40	HBSPL1080	80	60	1÷10	50
	HBSPL10100	100	75	1÷15	50
	HBSPL10120	120	95	1÷15	50
	HBSPL10140	140	110	1÷20	50
	HBSPL10160	160	130	1÷20	50
	HBSPL10180	180	150	1÷20	50

HBS PLATE EVO



PAN HEAD SCREW



d ₁ [mm]	CODE	L [mm]	b [mm]	A _T [mm]	A _p [mm]	pcs
8 TX 40	HBSPLEVO840	40	32	8	1÷10	100
	HBSPLEVO860	60	52	8	1÷15	100
	HBSPLEVO880	80	55	25	1÷15	100
	HBSPLEVO8100	100	75	25	1÷15	100
	HBSPLEVO8120	120	95	25	1÷15	100
	HBSPLEVO8140	140	110	30	1÷20	100
	HBSPLEVO8160	160	130	30	1÷20	100
	HBSPLEVO1060	60	52	8	1÷15	50
10 TX 40	HBSPLEVO1080	80	60	20	1÷15	50
	HBSPLEVO10100	100	75	25	1÷15	50
	HBSPLEVO10120	120	95	25	1÷15	50
	HBSPLEVO10140	140	110	30	1÷20	50
	HBSPLEVO10160	160	130	30	1÷20	50
	HBSPLEVO10180	180	150	30	1÷20	50
12 TX 50	HBSPLEVO12120	120	90	30	1÷15	25
	HBSPLEVO12140	140	110	30	1÷20	25
	HBSPLEVO12160	160	120	40	1÷20	25
	HBSPLEVO12180	180	140	40	1÷30	25
HBSPLEVO12200	200	160	40	1÷30	25	

LBS



ROUND HEAD SCREW FOR PLATES



d ₁ [mm]	CODE	L [mm]	b [mm]	pcs
5 TX 20	LBS525	25	21	500
	LBS540	40	36	500
	LBS550	50	46	200
	LBS560	60	56	200
	LBS570	70	66	200
7 TX 30	LBS760	60	55	100
	LBS780	80	75	100
	LBS7100	100	95	100

LBS EVO



ROUND HEAD SCREW FOR PLATES



d ₁ [mm]	CODE	L [mm]	b [mm]	pcs
5 TX 20	LBSEVO540	40	36	500
	LBSEVO550	50	46	200
	LBSEVO560	60	56	200
	LBSEVO570	70	66	200
7 TX 30	LBSEVO780	80	75	100
	LBSEVO7100	100	95	100

THREADED RODS, WASHERS AND NUTS

- Metric threaded products for connections and joints
- Available in carbon steel and A2 austenitic stainless steel for outdoor applications (SC3) up to 1 km from the sea and on T4 class timber

MGS 1000 - 4.8

THREADED ROD

CODE	rod	L [mm]	pcs
MGS10008	M8	1000	10
MGS100010	M10	1000	10
MGS100012	M12	1000	10
MGS100014	M14	1000	10
MGS100016	M16	1000	10
MGS100018	M18	1000	10
MGS100020	M20	1000	10
MGS100022	M22	1000	10
MGS100024	M24	1000	10
MGS100027	M27	1000	10
MGS100030	M30	1000	10

4.8 steel class - electrogalvanized
DIN 975



MGS 1000 - 8.8

THREADED ROD

CODE	rod	L [mm]	pcs
MGS10888	M8	1000	1
MGS11088	M10	1000	1
MGS11288	M12	1000	1
MGS11488	M14	1000	1
MGS11688	M16	1000	1
MGS11888	M18	1000	1
MGS12088	M20	1000	1
MGS12488	M24	1000	1
MGS12788	M27	1000	1

8.8 steel class - electrogalvanized
DIN 975



MGS 2200 - 4.8

THREADED ROD

CODE	rod	L [mm]	pcs
MGS220012	M12	2200	1
MGS220016	M16	2200	1
MGS220020	M20	2200	1

4.8 steel class - electrogalvanized
DIN 975



MGS AI 975

THREADED ROD

CODE	rod	L [mm]	pcs
AI9758	M8	1000	1
AI97510	M10	1000	1
AI97512	M12	1000	1
AI97516	M16	1000	1
AI97520	M20	1000	1

A2-70 (A2 | AISI304) stainless steel
DIN 975



ULS 9021

WASHER

CODE	rod	d _{INT} [mm]	d _{EXT} [mm]	s [mm]	pcs
ULS8242	M8	8,4	24,0	2,0	200
ULS10302	M10	10,5	30,0	2,5	200
ULS13373	M12	13,0	37,0	3,0	100
ULS15443	M14	15,0	44,0	3,0	100
ULS17503	M16	17,0	50,0	3,0	100
ULS20564	M18	20,0	56,0	4,0	50
ULS22604	M20	22,0	60,0	4,0	50

* ISO 7093 differs from DIN 9021 in the surface hardness.

HV 100 steel - electrogalvanized
DIN 9021 (ISO 7093*)

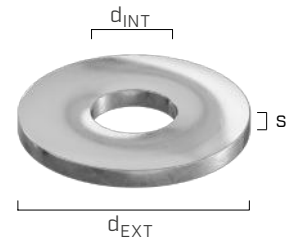

ULS 440

WASHER

CODE	rod	d _{INT} [mm]	d _{EXT} [mm]	s [mm]	pcs
ULS11343	M10	11,0	34,0	3,0	200
ULS13444	M12	14,0	44,0	4,0	200
ULS17565	M16	17,0	56,0	5,0	50
ULS22726	M20	22,0	72,0	6,0	50
ULS24806	M22	24,0	80,0	6,0	25

HV 100 steel - electrogalvanized
DIN 440 R

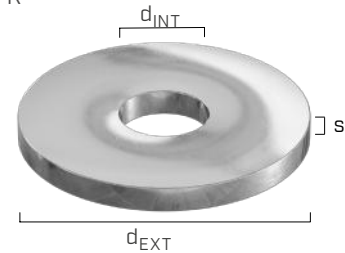

ULS 1052

WASHER

CODE	rod	d _{INT} [mm]	d _{EXT} [mm]	s [mm]	pcs
ULS14586	M12	14,0	58,0	6,0	50
ULS18686	M16	18,0	68,0	6,0	50
ULS22808	M20	22,0	80,0	8,0	25
ULS25928	M22	25,0	92,0	8,0	20
ULS271058	M24	27,0	105,0	8,0	20

HV 100-250 steel - electrogalvanized
DIN 1052

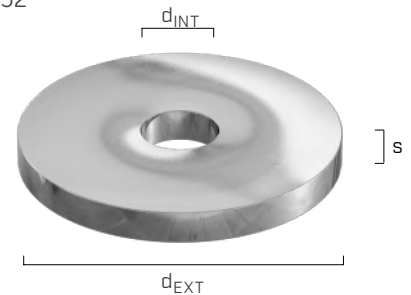

ULS 125

WASHER

CODE	rod	d _{INT} [mm]	d _{EXT} [mm]	s [mm]	pcs
ULS81616	M8	8,4	16,0	1,6	1000
ULS10202	M10	10,5	20,0	2,0	500
ULS13242	M12	13,0	24,0	2,5	500
ULS17303	M16	17,0	30,0	3,0	250
ULS21373	M20	21,0	37,0	3,0	250
ULS25444	M24	25,0	44,0	4,0	200
ULS28504	M27	28,0	50,0	4,0	100
ULS31564	M30	31,0	56,0	4,0	20

HV 100 steel - electrogalvanized
DIN 125 A (ISO 7089)

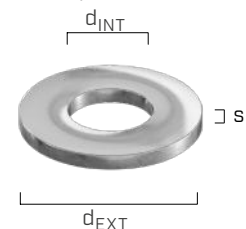

ULS AI 9021

WASHER

CODE	rod	d _{INT} [mm]	d _{EXT} [mm]	s [mm]	pcs
AI90218	M8	8,4	24,0	2,0	500
AI902110	M10	10,5	30,0	2,5	500
AI902112	M12	13,0	37,0	3,0	200
AI902116	M16	17,0	50,0	3,0	100
AI902120	M20	22,0	60,0	4,0	50

* ISO 7093 differs from DIN 9021 in the surface hardness.

A2 | AISI304 stainless steel
DIN 9021 (ISO 7093-1*)

A2
AISI 304



MUT 934

HEXAGONAL NUT

CODE	rod	SW [mm]	h [mm]	pcs
MUT9348	M8	13	6,5	400
MUT93410	M10	17	8,0	500
MUT93412	M12	19	10,0	500
MUT93414	M14	22	11,0	200
MUT93416	M16	24	13,0	200
MUT93418	M18	27	15,0	100
MUT93420	M20	30	16,0	100
MUT93422	M22	32	18,0	50
MUT93424	M24	36	19,0	50
MUT93427	M27	41	22,0	25
MUT93430	M30	46	24,0	25

* ISO 4032 differs from DIN 934 for parameter h and, for diameters M10, M12, M14 and M22 also for the SW parameter.

8 steel class - electrogalvanized
DIN 934 (ISO 4032*)

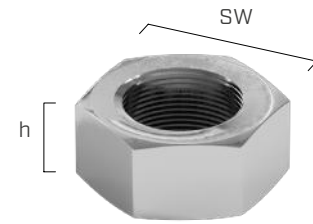

MUT AI 934

HEXAGONAL NUT

CODE	rod	SW [mm]	h [mm]	pcs
AI9348	M8	13	6,5	500
AI93410	M10	17	8,0	200
AI93412	M12	19	10,0	200
AI93416	M16	24	13,0	100
AI93420	M20	30	16,0	50

* ISO 4032 differs from DIN 934 for parameter h and, for diameters M10 and M12 also for the SW parameter.

A2-70 (A2 | AISI304) stainless steel
DIN 934 (ISO 4032*)

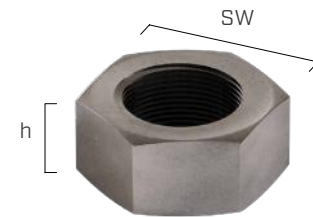

A2
AISI 304

MUT AI 985

SELF-LOCKING NUT

CODE	rod	SW [mm]	h [mm]	pcs
AI9858	M8	13	8,0	500
AI98510	M10	17	10,0	200
AI98512	M12	19	12,0	200
AI98516	M16	24	16,0	100

* ISO 10511 differs from DIN 995 for parameter h and, for diameters M10 and M12 also for the SW parameter.

A2-70 (A2 | AISI304) stainless steel
DIN 985 (ISO 10511*)



A2
AISI 304

MUT AI 1587

BLIND NUT

CODE	rod	SW [mm]	h [mm]	pcs
AI158710	M10	17	18,0	100
AI158712	M12	19	22,0	100
AI158716	M16	24	28,0	50
AI158720	M20	30	34,0	25

Single-piece turned nut.

A2 | AISI304 stainless steel
DIN 1587



A2
AISI 304

MUT 1587

BLIND NUT

CODE	rod	SW [mm]	h [mm]	pcs
MUT15878S	M8	13	15,0	200
MUT158710S	M10	17	18,0	50
MUT158712S	M12	19	22,0	50
MUT158714S	M14	22	25,0	50
MUT158716S	M16	24	28,0	50
MUT158718S	M18	27	32,0	50
MUT158720S	M20	30	34,0	25
MUT158722S	M22	32	39,0	25
MUT158724S	M24	36	42,0	25

Single-piece turned nut.

6 steel class - electrogalvanized
DIN 1587

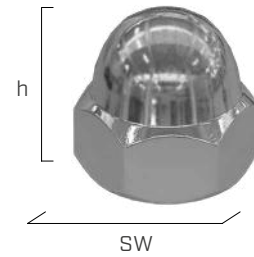

MUT 6334

CONNECTING NUT

CODE	rod	SW [mm]	h [mm]	pcs
MUT633410	M10	17	30,0	10
MUT633412	M12	19	36,0	10
MUT633416	M16	24	48,0	25
MUT633420	M20	30	60,0	10

8 steel class - electrogalvanized
DIN 6334

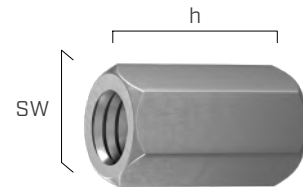

EKS

HEXAGONAL HEAD BOLT

- Steel class 8.8 - zinc plated
- DIN 933 (ISO 4017) - fully threaded

CODES AND DIMENSIONS

d [mm]	CODE	L [mm]	pcs
M10	EKS1030	30	25
	EKS1040	40	25
M12	EKS1240	40	25
	EKS1250	50	25
	EKS1260	60	25
M16	EKS1640	40	25
	EKS1650	50	25
	EKS1660	60	25

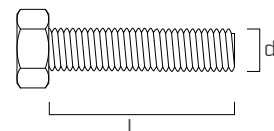

HEXAGONAL HEAD BOLT

KOS A2



KOS



ETA-11/0030

KOS A2 | AISI304 - hexagonal head bolt⁽¹⁾

A2 | AISI304 - DIN 931 stainless steel

A2
AISI 304

d [mm]	CODE	L [mm]	A _{max} [mm]	pcs
M12 SW19	AI60112100	100	75	25
	AI60112120	120	95	25
	AI60112140	140	115	25
	AI60112160	160	135	10
	AI60112180	180	155	10
	AI60112200	200	175	10
	AI60112220	220	195	10
	AI60112240	240	215	10
	AI60112260	260	235	10
M16 SW24	AI60116120	120	90	25
	AI60116140	140	110	25
	AI60116160	160	130	25
	AI60116180	180	150	10
	AI60116200	200	170	10
	AI60116220	220	190	10
	AI60116240	240	210	10
	AI60116260	260	230	10
	AI60116280	280	250	10
M20 SW30	AI60120160	160	125	10
	AI60120180	180	145	10
	AI60120200	200	165	10
	AI60120220	220	185	10
	AI60120240	240	205	10
	AI60120260	260	225	10
	AI60120280	280	245	10
	AI60120300	300	265	10
	AI60120320	320	285	5
AI60120340	340	305	5	
AI60120360	360	325	5	
AI60120380	380	345	5	
AI60120400	400	365	5	

⁽¹⁾Not holding CE marking.



The maximum fastenable thickness A_{max} is calculated considering use of the MUTA934 nut (see page 271) and two ULS AI 9021 washers (see page 270).

KOS - hexagonal head bolt with nut

steel class 8.8 - electrogalvanized - DIN 601

Zn
ELECTRO
PLATED

d [mm]	CODE	L [mm]	b [mm]	A _{max} [mm]	pcs
M12 SW19	KOS12100B	100	30	75	25
	KOS12120B	120	30	95	25
	KOS12140B	140	36	115	25
	KOS12160B	160	36	135	25
	KOS12180B	180	36	155	25
	KOS12200B	200	36	175	25
	KOS12220B	220	49	195	15
	KOS12240B	240	49	215	15
	KOS12260B	260	49	235	15
	KOS12280B	280	49	255	15
	KOS12300B	300	49	275	15
	KOS12320B	320	49	295	15
M16 SW24	KOS12340B	340	49	315	15
	KOS12360B	360	49	335	15
	KOS12380B	380	49	355	15
	KOS12400B	400	49	375	15
	KOS16140B	140	44	105	15
	KOS16160B	160	44	125	15
	KOS16180B	180	44	145	15
	KOS16200B	200	44	165	15
	KOS16220B	220	57	185	15
	KOS16240B	240	57	205	10
	KOS16260B	260	57	225	10
	KOS16280B	280	57	245	10
M20 SW30	KOS16300B	300	57	265	10
	KOS16320B	320	57	285	10
	KOS16340B	340	57	305	10
	KOS16360B	360	57	325	5
	KOS16380B	380	57	345	5
	KOS16400B	400	57	365	5
	KOS16420B	420	57	385	5
	KOS16440B	440	57	405	5
	KOS16460B	460	57	425	5
	KOS16500B	500	57	465	5
	KOS20140B	140	52	95	10
	KOS20160B	160	52	115	10
KOS20180B	180	52	135	10	
KOS20200B	200	52	155	5	
KOS20220B	220	65	175	5	
KOS20240B	240	65	195	5	
KOS20260B	260	65	215	5	
KOS20280B	280	65	235	5	
KOS20300B	300	65	255	5	
KOS20320B	320	65	275	5	
KOS20340B	340	65	295	5	
KOS20360B	360	65	315	5	
KOS20380B	380	65	335	5	
KOS20400B	400	65	355	5	
KOS20420B	420	65	375	5	
KOS20440B	440	65	395	5	
KOS20460B	460	65	415	5	



The maximum fastenable thickness A_{max} is calculated considering use of the MUT934 nut (see page 271) and two ULS 440 washers (see page 270).

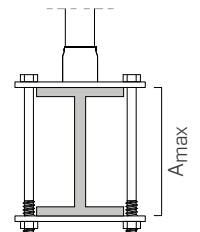

This catalogue is the exclusive property of Rotho Blaas and may not be copied, reproduced or published, totally or in part, without prior written consent. All violations will be prosecuted according to law.

The most up-to-date technical documentation is available on the Rotho Blaas website. Rotho Blaas is not liable for any printing errors related to technical data, drawings, references to weights and measurements, and translations in the catalogues.

Rotho Blaas reserves the right to modify its product range, characteristics, technical specifications and other documentation at any time without prior notice.

Installers, designers, engineers, users and buyers must visit www.rothoblaas.com before each use of a product.

Each product is designed for the specific load capacities and applications outlined in the technical documentation, in accordance with the limitations and additional information provided therein. While the products are engineered for a wide range of applications, Rotho Blaas disclaims any liability for determining their suitability for a specific use. It is the sole responsibility of the user to assess the product's appropriateness for the intended application and to ensure proper installation. Each intended use of a product must be evaluated and approved by qualified professionals.

Rotho Blaas does not guarantee the legal or design conformity of the data and calculations provided. The calculation tools provided are for indicative purposes only and serve as a purely technical-commercial aid to support sales activities. The values resulting from "test" are based on the actual experimental investigations results and valid only for the test conditions specified.

Rotho Blaas does not guarantee and in no case can be held responsible for damages, losses and costs or other consequences, for any reason (warranty for defects, warranty for malfunction, product or legal responsibility, etc.) deriving from the use, inability of use or non-conforming use of the product.

Images are for illustrative purposes only and may not fully represent the product's features. Accessories shown in pictures and renderings may not be included. Packaged quantities may vary.

In the event of discrepancies between the language versions of the catalogue, the Italian text shall be considered the official version and take precedence over all other translations.

The general purchase conditions of Rotho Blaas Srl are available on the website www.rothoblaas.com.

All rights reserved

© 2025 ROTHO BLAAS SRL

All renderings © ROTHO BLAAS SRL

Publication date - 1/4/2025



Solutions for Building Technology

- FASTENING
- AIRTIGHTNESS AND WATERPROOFING
- SOUNDPROOFING
- FALL PROTECTION
- TOOLS AND MACHINES

Rothoblaas is the multinational Italian company that has made innovative technology its mission, making its way to the forefront for timber buildings and construction safety in just a few years. Thanks to its comprehensive product range and the technically-prepared and widespread sales network, the company promotes the transfer of its know-how to the customers and aims to be a prominent and reliable partner for developing and innovating products and building methods. All of this contributes to a new culture of sustainable construction, focused on increasing comfortable living and reducing CO₂ emissions.

ROTHO BLAAS SRL

Via dell'Adige N.2/1 | 39040, Cortaccia (BZ) | Italia
Tel: +39 0471 81 84 00 | Fax: +39 0471 81 84 84
info@rothoblaas.com | www.rothoblaas.com

