



DEPER
HOSPITALITY

**Coffee
Machines**

Home

OCS-FM

OCS-PM

Ho.Re.Ca

Vending

Coffee to Go

JL05



JL29B



JL22



JL36



JL28



JL510



JL06



JL30



JL23



JL32



JL560



JL08



JL31A



JL24



JL33



JL40



JL852



JL09



JL31B

JL18



JL35

JL220



JL10



JL26



JL300



JL15



JL50



JL500



JL550





Equipped with commercial-grade grinding and brewing system, ensuring premium coffee quality in every cup. Featuring a sleek design, smart controls, and user-friendly operation, it allows you to craft barista-quality coffee in your own house.



JL05

CCC CE CB

Daily Output:
10 cups

Colors:



Optional Accessory:
Milk Tank



Commercial-Grade Grinding & Brewing

Equipped with patented SGH64 commercial grinder and S14 espresso brewer, ensuring professional stability and authentic coffee flavor in every cup.



Smak APP Control

Allows remote ordering via mobile app, personalized coffee customization, and saving preferences for a tailor-made coffee experience.



Adjustable Coffee Strength

Manual knob for coffee strength adjustment to suit different taste preferences, ensuring every cup is perfectly tailored to your taste.

Model	Power	Dimensions	Net Weight	Grinder	Brewer	Heating	Pump	Milk System
JL05A	1600W	240 (W)*360 (H)*450 (D) mm	9.5kg	SGH64 x 1	S14 x 1	Thermoblock x 1	Piston pump x 1	—
JL05B	1600W	240 (W)*360 (H)*450 (D) mm	10kg	SGH64 x 1	S14 x 1	Thermoblock x 1	Piston pump x 1	Milk frother
JL05C	1600W	240 (W)*360 (H)*450 (D) mm	10.5kg	SGH64 x 1	S14 x 1	Thermoblock x 1	Piston pump x 1	—

Steam Wand	Spout Height	Bean Hopper	Water Tank	Drip Tray	Waste Bin
—	80-140mm	200g x 1	1.6L	0.6L	10 cakes (8g)
—	80-140mm	200g x 1	1.6L	0.6L	10 cakes (8g)
1	80-140mm	200g x 1	1.6L	0.6L	10 cakes (8g)



JL06

CCC CE CB

Daily Output :
10 cups

Colors:
● ●

Optional Accessory:
Milk Tank



Innovative Design

Crafted by Italian designers with a stylish and distinctive look. Features a curved menu interface for an intuitive and user-friendly experience.



Cold Brew Coffee

Fast cold brew technology delivers smooth, naturally sweet cold brew coffee in just 5 minutes, preserving the original flavor and aroma of the coffee.



Detachable Brewer for Easy Cleaning

Smalily designed brewing unit allows for quick disassembly and easy cleaning, ensuring a consistently hygienic machine interior.

Model	Power	Dimensions	Net Weight	Grinder	Brewer	Heating	Pump	Milk System
JL06A	1600W	240 (W)*360 (H)*450 (D) mm	9.5kg	SGH64 x 1	S14 x 1	Thermoblock x 1	Piston pump x 1	—
JL06B	1600W	240 (W)*360 (H)*450 (D) mm	10kg	SGH64 x 1	S14 x 1	Thermoblock x 1	Piston pump x 1	Milk frother
JL06C	1600W	240 (W)*360 (H)*450 (D) mm	10.5kg	SGH64 x 1	S14 x 1	Thermoblock x 1	Piston pump x 1	—

Steam Wand	Spout Height	Bean Hopper	Water Tank	Drip Tray	Waste Bin
—	80-140mm	200g x 1	1.6L	0.6L	10 cakes (8g)
—	80-140mm	200g x 1	1.6L	0.6L	10 cakes (8g)
1	80-140mm	200g x 1	1.6L	0.6L	10 cakes (8g)



JL15

CCC CE CB

Daily Output :
60 cups

Colors:
● ○

Optional Accessory:
Milk Tank / Fresh Milk Fridge

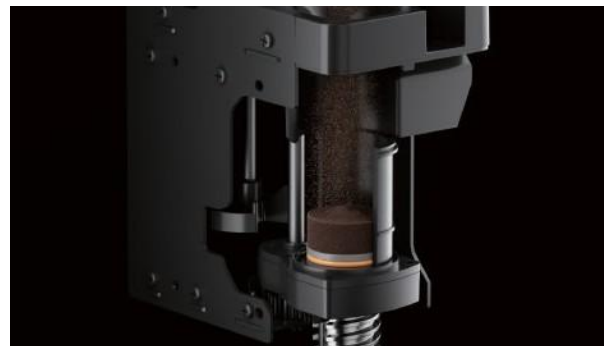

Professional Coffee Extraction

Equipped with JETINNO' s patented S14 brewer (optional S20), featuring high-pressure espresso extraction for precise control over the brewing process, ensuring consistent coffee quality in every cup.



Beverage Customization

Advanced backend settings allow users to fully customize their drinks, offering endless customization possibilities to satisfy coffee enthusiasts' desire for exploration.



Smak Auto-Cleaning

One-touch automatic cleaning for the brewer and fresh milk system, ensuring effofiless maintenance and hygiene.

Model	Power	Dimensions	Net Weight	Grinder	Brewer	Heating	Pump	Milk System
JL08	1700W	300 (W)*440 (H)*490 (D) mm	15kg	SGH64 x 1	S14x1/S20 (optional)	Thermoblock x 1	Piston pump x 1	—
JL09	1700W	300 (W)*440 (H)*490 (D) mm	15kg	SGH64 x 1	S14x1/S20 (optional)	Thermoblock x 1	Piston pump x 1	—
JL10	1700W	300 (W)*440 (H)*490 (D) mm	15kg	SGH64 x 1	S14x1/S20 (optional)	Thermoblock x 1	Piston pump x 1	Milk frother
JL15	1700W	300 (W)*440 (H)*490 (D) mm	16kg	SGH64 x 1	S14x1/S20 (optional)	Thermoblock x 2	Piston pump x 1	Milk frother

Steam Wand	Drip Tray	Bean Hopper	Daily Output	Water Tank	Waste Bin
—	0.7L	500g x 1	30	2L, Opt. 8L	40 cakes (10g)
1	0.7L	500g x 1	30	2L, Opt. 8L	40 cakes (10g)
—	0.7L	500g x 1	30	2L, Opt. 8L	40 cakes (10g)
—	0.7L	500g x 1	60	2L, Opt. 8L	40 cakes (10g)



Combining high-efficiency grinding with professional espresso extraction, OCS-FM machines precisely unlocks the bold, aromatic flavors of coffee while delivering a smooth, well-rounded taste. The innovative fresh milk system creates smooth, velvety milk foam that blends perfectly with coffee for a creamy, indulgent experience. With intelligent auto-cleaning and detachable components, maintenance is more convenient and efficient.



JL29B

CQC CE CB

Daily Output: 100 cups
Colors:



JL30

CQC CE CB

Daily Output: 100 cups
Colors:
Optional Accessory: Fresh Milk Fridge



Professional Espresso Extraction

Equipped with patented S14 brewer (optional S20), delivering high-pressure espresso extraction with rich crema, ensuring premium beverage quality for every cup.



Quick-Release Cleaning for Hygiene Assurance

One-touch quick-release brewing unit for easy cleaning, keeping the machine interior consistently clean and hygienic.



Smak Bean Shokage Detection

Intelligent bean shofiage alefis to ensure timely refilling, optimizing operational efficiency.



Model	Power	Dimensions	Net Weight	Grinder	Brewer	Heating	Pump	Milk System
JL29B	1500W	300 (W)*548 (H)*490 (D)mm	16kg	SGH64 x 1	S14x1/S20 (optional)	Thermoblock x 1	Piston pump x 1	—
JL30	1500W	300 (W)*548 (H)*490 (D)mm	17kg	SGH64 x 1	S14x1/S20 (optional)	Thermoblock x 2	Piston pump x 1	Milk frother

Screen Type	Spout Height	Drip Tray	Bean Hopper	Water Tank	Waste Bin
7" touch screen	80-160mm	1L, direct drainage (optional)	1200g x 1	2L, Opt. 8L	50 cakes (10g), direct slagging off (optional)
7" touch screen	80-160mm	1L, direct drainage (optional)	1200g x 1	2L, Opt. 8L	50 cakes (10g), direct slagging off (optional)



JL31A

CQC CE CB

Daily Output:
100 cups

Colors:
● ●

Optional Accessory:
Fresh Milk Fridge



JL31B

CQC CE CB

Daily Output:
100 cups

Colors:
● ●

Optional Accessory:
Fresh Milk Fridge



Dual Pump & Dual Boiler

High-efficiency dual pump and dual boiler design enables simultaneous coffee and milk preparation, improving beverage production speed and reducing wait times—perfect for handling peak hours with ease.



Versatile Water Supply Options

Built-in 2L water tank (optional 8L), compatible with barreled water and direct tap water. Three flexible water supply options to suit different operational needs.



Hot Water Spout

Equipped with a dedicated hot water spout for one-touch dispensing, ensuring convenience and efficiency.



Model	Power	Dimensions	Net Weight	Grinder	Brewer	Heating	Pump	Milk System
JL31A	2850W	300(W)*548(H)*490(D)mm	18kg	SGH64 x 1	S14x1/S20 (optional)	Thermoblock x 2	Piston pump x 2	Milk frother
JL31B	2850W	300(W)*548(H)*490(D)mm	19kg	SGH64 x 1	S14x1/S20 (optional)	Thermoblock x 2	Piston pump x 2	Milk frother

Screen Type	Hot Water Spout	Drip Tray	Bean Hopper	Water Tank	Waste Bin
7" touch screen	1	1L, direct drainage (optional)	1200g x 1	2L, Opt. 8L	50 cakes (10g), direct slugging off (optional)
10.1" touch screen	1	1L, direct drainage (optional)	1200g x 1	2L, Opt. 8L	50 cakes (10g), direct slugging off (optional)



A fully automatic freshly ground coffee machine equipped with professional grinding and extraction systems to ensure consistent, high-quality coffee in high-demand environments. Its multi-Mix canister design offers a variety of coffee flavors and instant beverage options.



JL22/23

CQC CE CB

Daily Output:
150 cups

Colors:
●

Optional Accessory:
Base cabinet



Advanced Brewing System

Equipped with a high-performance P14 brewer (optional P20) and a 2700W storage boiler, ensuring stable 9-bar pressure and 92° C optimal extraction for consistently exceptional beverage quality.



Compact Design

Sleek and space-saving, designed to fit into limited spaces while seamlessly integrating into various commercial environments.



10+ Beverage Options

Multi-canister design enables the preparation of a wide range of drinks, including black coffee, milk-based coffee, and instant beverages, catering to diverse consumer preferences.

Model	Power	Dimensions	Net Weight	Grinder	Brewer	Heating	Pump
JL22-ES4C	2700W	400 (W) *675 (H) *550 (D) mm	42kg	PGH64 x 1	P14x1/P20 (optional)	Boiler x 1	Piston pump x 1
JL22-IN5C	2700W	400 (W) *580 (H) *550 (D) mm	40kg	—	—	Boiler x 1	Piston pump x 1
JL23-ES4C	2700W	400 (W) *667 (H) *550 (D) mm	42kg	Ditting EK7 x 1	P14x1/P20 (optional)	Boiler x 1	Gear pump x 1

Mixer	Screen Type	Spout Height	Drip Tray	Bean Hopper	Instant Canister	Waste Bin
2	10.1" touch screen	80-115mm	1.5L, direct drainage (optional)	1.5kg x 1	1.5L x 3	50 cakes direct slagging off (optional)
3pcs 4pcs (optional)	10.1" touch screen	80-115mm	1.5L, direct drainage (optional)	—	1.5L x 5	—
2	10.1" touch screen	80-115mm	1.5L, direct drainage (optional)	1.5kg x 1	1.5L x 3	50 cakes direct slagging off (optional)



JL24

CQC CE CB

Daily Output:
150 cups

Colors:



Optional Accessory:
Base cabinet

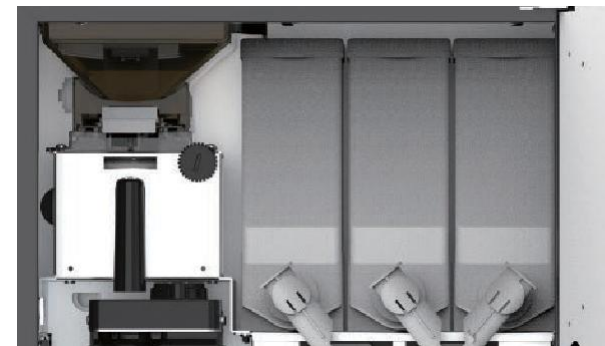

Large Capacity Design

The larger mix canister capacity reduces the need for frequent refills, making it ideal for high-usage, space-limited office or commercial environments.



14-Inch Touchscreen

The 14-inch touchscreen, combined with an intuitive Android OS, provides easy self-ordering on the front end and seamless equipment management on the back end, enhancing both user experience and operational efficiency.



Enhanced Performance

The efficient dehumidification system prevents instant mix from clumping, while the machine's excellent sealing design keeps foreign objects out, ensuring the hygiene and safety of every beverage and guaranteeing premium quality in each cup.

Model	Power	Dimensions	Net Weight	Grinder	Brewer	Heating	Pump
JL24-ES4C	2700W	420 (W) *740 (H) *535 (D) mm	45kg	PGH64 x 1	P14x1/P20 (optional)	Boiler x 1	Piston pump x 1
JL24-IN5C	2700W	420 (W) *671 (H) *535 (D) mm	42kg	—	—	Boiler x 1	Piston pump x 1

Mixer	Screen Type	Spout Height	Drip Tray	Bean Hopper	Instant Canister	Waste Bin
2	14" touch screen	80-120mm	1.5L, direct drainage (optional)	1.5kg x 1	2L x 3	50 cakes direct slagging off (optional)
3pcs 4pcs (optional)	14" touch screen	80-120mm	1.5L, direct drainage (optional)	—	2L x 5	—



JL18

CQC CE CB

Daily Output:
250 cups

Colors:



Optional Accessory:
Base cabinet



Precise Grinding

Equipped with the Ditting EMH64 professional grinder, offering precise and efficient grinding, providing solid hardware support for high-quality coffee output and quick cup delivery.



Premium Coffee Brewer

Featuring the high-performance P14 brewer (optional P20) and a 2700W Storage Boiler, ensuring efficient and stable 9-bar pressure and 92° C optimal extraction for premium coffee quality.



14-Inch Vertical Screen

Compact body with a 14-inch vertical screen, offering powerful performance in a small form factor, ideal for various commercial environments.

Model	Power	Dimensions	Net Weight	Grinder	ES Brewer	Filter Brewer	Heating	Pump
JL18-ES3C	2700W	310 (W)*713 (H)*482 (D)mm	40.5kg	Ditting EMH64 x1 Jetinno PGH64 (optional)	P14x1/P20 (optional)	—	Boiler x 1	Gear pump x 1
JL18-BTC3C	2700W	310 (W)*713 (H)*482 (D)mm	40.5kg	Ditting EMH64 x1 Jetinno PGH64 (optional)	—	14g x 1 (coffee)	Boiler x 1	Piston pump x 1

Mixer	Screen Type	Hot Water Spout	Drip Tray	Bean Hopper	Instant Canister	Waste Bin
1	14" touch screen	1	1.3L, direct drainage (optional)	1.8kg x 1	3.5L x 1 +2.3L x 1	50 cakes direct slagging off (optional)
1	14" touch screen	1	1.3L, direct drainage (optional)	1.8kg x 1	3.5L x 1 +2.3L x 1	50 cakes direct slagging off (optional)



JL26

CQC CE CB

Daily Output :
250 cups

Colors:



Optional Accessory:
Base cabinet

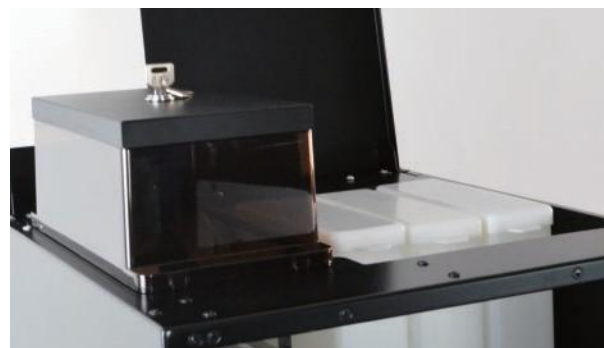

Efficient Grinding

Equipped with the Ditting EMH64 professional grinder, ensuring precise and efficient grinding for high-quality coffee output and quick cup delivery.



Large Capacity Design

The expanded canister capacity reduces the need for frequent refills, making it ideal for high-usage, space-limited office or commercial environments.



Multi-Canister Design

1 bean hopper and 3 instant canisters, capable of preparing over 10 different types of coffee and instant beverages to meet diverse consumer needs.

Model	Power	Dimensions	Net Weight	Grinder	ES Brewer	Filter Brewer	Heating	Pump
JL26-ES4C	2700W	420 (W) *808 (H) *520 (D) mm	50kg	Ditting EMH64 x 1	P14x1/P20 (optional)	—	Boiler x 1	Gear pump x 1
JL26-ESFB4C	2700W	420 (W) *808 (H) *520 (D) mm	50kg	Ditting EMH64 x 1	P14x1/P20 (optional)	14g x 1 (tea)	Boiler x 1	Gear pump x 1
JL26-BTC4C	2700W	420 (W) *808 (H) *520 (D) mm	50kg	Ditting EMH64 x 1	—	14g x 1 (coffee)	Boiler x 1	Piston pump x 1

Mixer	Screen Type	Hot Water Spout	Drip Tray	Bean Hopper	Instant Canister	Waste Bin
2	14" touch screen	1	1.5L, direct drainage (optional)	1.5kg x 1	2L x 3	80 cakes direct slagging off (optional)
1	14" touch screen	1	1.5L, direct drainage (optional)	1.5kg x 1	2L x 3	80 cakes direct slagging off (optional)
2	14" touch screen	1	1.5L, direct drainage (optional)	1.5kg x 1	2L x 3	80 cakes direct slagging off (optional)



JL50

CQC CE CB

Daily Output:
250 cups

Colors:



Optional Accessory:
Base cabinet

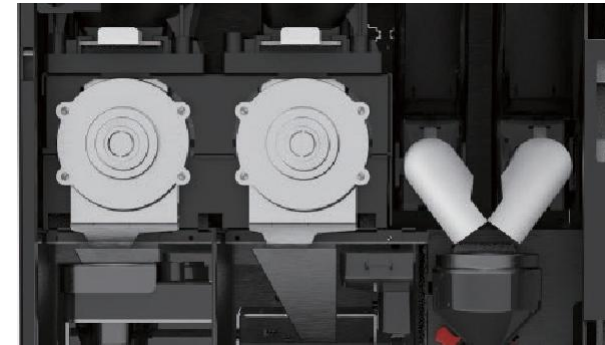

Dual Grinder and Dual Brewers

Dual bean hoppers, dual grinders, and dual brewing systems allow for two different coffee beans, enhancing both performance and efficiency.



Strong and Stable Performance

Equipped with commercial-grade components, including storage boiler and gear pump, significantly improving efficiency and stability, ensuring fast beverage delivery even during peak hours.



Diverse Beverage Options

Featuring dual bean hoppers and 2. 3L + 3. 5L canisters, capable of preparing over 10 different types of coffee and instant beverages.

Model	Power	Dimensions	Net Weight	Grinder	ES Brewer	Filter Brewer	Heating	Pump
JL50A	2700W	365 (W) *750 (H) *535 (D) mm	60kg	Ditting EMH64 x 2	P14 x2 / P20 (optional)	—	Boiler x 1	Gear pump x 1
JL50B	2700W	365 (W) *750 (H) *535 (D) mm	60kg	Ditting EMH64 x 2	P14 x1 / P20 (optional)	14g x 1 (coffee)	Boiler x 1	Gear pump x 1

Mixer	Screen Type	Hot Water Spout	Drip Tray	Bean Hopper	Instant Canister	Waste Bin
1	14" touch screen	1	1L, direct drainage (optional)	5Lx1+2. 8Lx1	2. 3L x1 +3. 5L x1	80 cakes direct slagging off (optional)
1	14" touch screen	1	1L, direct drainage (optional)	5Lx1+2. 8Lx1	2. 3L x1 +3. 5L x1	80 cakes direct slagging off (optional)



Designed for commercial establishments, Ho. Re. Ca Machines feature professional high-efficiency grinding and stable high-pressure extraction, delivering rich and intense espresso flavors. The advanced fresh milk system creates dense, creamy milk foam for a smooth and refined taste. Smafi operation supports one-touch brewing, remote management, and auto-cleaning, making it an ideal solution for high-quality coffee service in business settings.



JL36

CQC CE CB

Daily Output:
100 cups

Colors:



Optional Accessory:
Fresh Milk Fridge / Base cabinet



Stylish Design

Expecially crafted by Italian designers, featuring a 10.1-inch touchscreen, mirror-finish stainless steel front panel, and three-color breathing lights, highlighting its premium feel.



Smak Auto-Cleaning

Innovative automatic milk system cleaning function with one-touch cleaning and no manual intervention required. The intelligent timed cleaning feature ensures worry-free maintenance.



Removable Bean Hopper

The bean hopper can be easily removed with one touch, allowing for quick bean changes to cater to different flavor preferences and enhancing user convenience.

Model	Power	Dimensions	Net Weight	Grinder	ES Brewer	Heating	Pump	Milk System
JL36A	3200W	300 (W) *585 (H) *512 (D) mm	22kg	SGH64 x 1	S14x1/S20 (optional)	Thermoblock x 2	Piston pump x 2	Milk frother
JL36B	1700W	300 (W) *585 (H) *512 (D) mm	20kg	SGH64 x 1	S14x1/S20 (optional)	Thermoblock x 1	Piston pump x 1	—

Screen Type	Spout Height	Drip Tray	Bean Hopper	Water Tank	Waste Bin
10.1" touch screen	105-180mm	1.2L, direct drainage (optional)	1200g x 1	2L, Opt. 8L	70 cakes (10g) direct slagging off (optional)
10.1" touch screen	105-180mm	1.2L, direct drainage (optional)	1200g x 1	2L, Opt. 8L	70 cakes (10g) direct slagging off (optional)



JL32

CQC CE CB

Daily Output :
200 cups

Colors:



Optional Accessory:

Fresh Milk Fridge / Base cabinet



Dual Pump & Dual Boiler

Simultaneous coffee and fresh milk preparation, improving beverage production efficiency and reducing wait time for customers.



Dual Canister Design

Dual instant canisters supporting over 20 types of coffee and instant beverages to meet diverse consumer needs.



Effortless Maintenance

Multi-mode automatic cleaning with an intelligent monitoring system, simplifying maintenance and enhancing operational efficiency.

Model	Power	Dimensions	Net Weight	Grinder	ES Brewer	Heating	Pump	Milk System
JL32A	2900W	350 (W) *620 (H) *560 (D) mm	30kg	PGH64 x 1	P20x1/P14 (optional)	Boiler x 1 Thermoblock x 1	Piston pump x 2	Milk frother
JL32B	2900W	350 (W) *620 (H) *560 (D) mm	29kg	PGH64 x 1	P20x1/P14 (optional)	Boiler x 1 Thermoblock x 1	Piston pump x 2	Milk frother
JL32C	2900W	350 (W) *620 (H) *560 (D) mm	29kg	PGH64 x 1	P20x1/P14 (optional)	Boiler x 1	Piston pump x 1	—

Screen Type	Drip Tray	Bean Hopper	Instant Canister	Water Tank	Waste Bin
10.1" touch screen	0.6L, direct drainage (optional)	1500g x 1	3L x 1 + 2L x 1	4L	40 cakes (8g) direct slagging off (optional)
10.1" touch screen	0.6L, direct drainage (optional)	1500g x 1	—	4L	40 cakes (8g) direct slagging off (optional)
10.1" touch screen	0.6L, direct drainage (optional)	1500g x 1	3L x 1 + 2L x 1	4L	40 cakes (8g) direct slagging off (optional)



JL33

CQC CE CB

Daily Output :
200 cups

Colors:



Optional Accessory:
Fresh Milk Fridge / Base cabinet



Dual Bean Hopper & Dual Grinder

This machine allows for the simultaneous use of two different coffee beans, with two grinding systems operating independently.



High-Performance Brewing System

Equipped with the high-performance P14 brewer (optional P20) and a 2700W storage boiler, achieving efficient and stable 9-bar pressure and 92° C optimal extraction for premium coffee quality.



Three Water Supply Options

Built-in 4L water tank, with the option to connect to pressurized direct drinking water or bottled water, providing flexibility for various usage scenarios.



Model	Power	Dimensions	Net Weight	Grinder	ES Brewer	Heating	Pump	Milk System
JL33A	2900W	350 (W) *628 (H) *560 (D) mm	33kg	PGH64 x 2	P20x1/P14 (optional)	Boiler x 1 Thermoblock x 1	Piston pump x 2	Milk frother
JL33B	2900W	350 (W) *628 (H) *560 (D) mm	32kg	PGH64 x 2	P20x1/P14 (optional)	Boiler x 1 Thermoblock x 1	Piston pump x 2	Milk frother
JL33C	2900W	350 (W) *628 (H) *560 (D) mm	32kg	PGH64 x 2	P20x1/P14 (optional)	Boiler x 1	Piston pump x 1	—
JL33D	2900W	350 (W) *628 (H) *560 (D) mm	31kg	PGH64 x 2	P20x1/P14 (optional)	Boiler x 1	Piston pump x 1	—

Screen Type	Drip Tray	Bean Hopper	Instant Canister	Water Tank	Waste Bin
10.1" touch screen	0.6L, direct drainage (optional)	1000g x 2	2L x 1 + 1.5L x 1	4L	40 cakes (8g) direct slagging off (optional)
10.1" touch screen	0.6L, direct drainage (optional)	1000g x 2	—	4L	40 cakes (8g) direct slagging off (optional)
10.1" touch screen	0.6L, direct drainage (optional)	1000g x 2	2L x 1 + 1.5L x 1	4L	40 cakes (8g) direct slagging off (optional)
10.1" touch screen	0.6L, direct drainage (optional)	1000g x 2	—	4L	40 cakes (8g) direct slagging off (optional)



JL35

CQC CE CB

Daily Output :
250 cups

Colors:



Optional Accessory:
Fresh Milk Fridge / Base cabinet

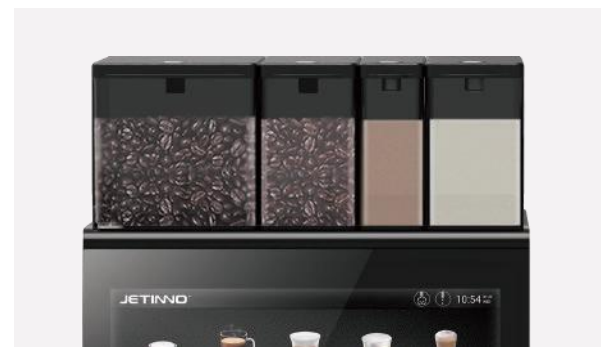

Dual Grinding & Brewing System

Dual bean hoppers paired with the high-performance Ditting EMH64 dual grinder and P14/P20 premium brewers, meeting diverse coffee flavor demands with exceptional performance.



Hot & Cold Milk Frothing

Featuring the Italian Fluid-o-tech milk pump, which precisely controls the temperature and humidity of the milk foam, producing fine, smooth hot and cold milk foam to enhance the flavor and quality of fresh milk coffee.



Diverse Beverage Flavors

Two large-capacity mix canisters and six syrup lines offering the flexibility to create a wide variety of flavored drinks, satisfying diverse consumer preferences.

Model	Power	Dimensions	Net Weight	Grinder	ES Brewer	Heating	Pump	Milk System
JL35A	3100W	365 (W)*730 (H)*535 (D)mm	66kg	Ditting EMH64 x 2	P14x2/P20 (optional)	Boiler x 2	Gear pump x 1	Milk pump
JL35B	3100W	365 (W)*730 (H)*535 (D)mm	58kg	Ditting EMH64 x 1	P14x1/P20 (optional)	Boiler x 2	Gear pump x 1	Milk pump

Screen Type	Mixer	Bean Hopper	Instant Canister	Syrup	Drip Tray	Waste Bin
14" touch screen	1	5Lx 1+2. 8Lx 1	2. 3L x 1 +3. 5L x 1	Optional 6 groups	1L, direct drainage (optional)	80 cakes direct slagging off (optional)
14" touch screen	2	5Lx 1	2. 3L x 1 +3. 5L x 2	Optional 6 groups	1L, direct drainage (optional)	80 cakes direct slagging off (optional)



Delivering exceptional coffee flavor and a diverse selection of beverages. Equipped with an intelligent self-service system, it features automatic cup dispensing, remote management, and multiple payment options. Designed for efficiency and personalization, it redefines modern beverage consumption.



JL28

CQC CE CB

Daily Output:
200 cups

Colors:
● ●

Optional Accessory:
Base cabinet



JL40

CQC CE CB

Daily Output:
200 cups

Colors:
●

Optional Accessory:
Base cabinet



Built-in Cup Dispenser

Stores up to 75 cups, with an intelligent automatic cup dispensing system, eliminating the need for manual cup retrieval. This saves time and reduces potential contamination.



Multi-Canister Design

Equipped with four instant canisters, capable of preparing over 10 types of coffee and instant beverages, including classic coffee, milk-based drinks, and juice—perfect for catering to diverse taste preferences.



Exceptional Performance & Stability

Features a 2700W high-efficiency storage boiler, combined with a precision gear pump to ensure stable temperature and pressure output. Its strong refilling capability meets high-demand usage, providing a seamless and reliable experience.



Model	Power	Dimensions	Net Weight	Grinder	ES Brewer	Heating	Pump
JL28	2700W	420 (W)*800 (H)*660 (D) mm	60kg	PGH64 x 1	P14x1/P20 (optional)	Boiler x 1	Gear pump x 1
JL40	2800W	420 (W)*805 (H)*650 (D) mm	60kg	PGH64 x 1	P20x1/P14 (optional)	Boiler x 1	Gear pump x 1

Cup Delivery Door	Cup Number	Bean Hopper	Instant Canister	Drip Tray	Waste Bin
Manual cup delivery door	75	1.5kg x 1	2L x 2+ 1.5L x 2	1.5L, direct drainage (optional)	130 cakes direct slagging off (optional)
Manual cup delivery door	75	1.5kg x 1	3L x 2+ 2L x 2	1.5L, direct drainage (optional)	130 cakes direct slagging off (optional)



JL220

CQC CE CB

Daily Output:
200 cups

Colors:



Compact Design with Smak Features

Equipped with a 14-inch vertical screen and PIR motion-sensing technology for an intuitive and smart user experience. With a footprint of just 0.35m², it is ideal for compact office or commercial spaces.



Diverse Beverage Options

Features 1 bean hopper and 5 instant mix canisters, offering 20+ beverage choices to cater to various taste preferences.



Effortless Maintenance

Multiple automatic cleaning options, advanced intelligent detection, and IoT backend management simplify maintenance, allowing for a hassle-free and efficient operation.

Model	Power	Dimensions	Net Weight	Grinder	ES Brewer	Heating	Pump
JL220	2900W	500 (W)*1675 (H)*700 (D)mm	100kg	PGH64 x 1	P20x1/P14 (optional)	Boiler x 1	Piston pump x 1

Cup Delivery Door	Cup Number	Lid Number	Cup Specifications	Bean Hopper	Instant Canister	Drip Tray	Waste Bin
Cup Delivery Door	120	90	D80mm, 10 Oz	1.8kg x1	4L x 2+ 2L x 3	15L	130 cakes



JL300

CQC CE CB

Daily Output :
150 cups

Colors:
● ●

Optional Accessory:
BIB / Top Light Box



Built-in Cup Dispenser

Stores up to 150 cups with an intelligent automatic cup dispensing system, enabling a fully self-service experience. From bean to cup, enjoy fresh coffee with just one touch.



Immersive Self-Service Experience

Transparent bean hopper design provides a clear view of the grinding process. Features automatic cup dispensing, automatic lift door, manual lid retrieval, and a packaging shelf, enhancing the overall coffee purchase experience.



Powerful Backend Management

Integrated with the advanced SaaS coffee machine management platform, supporting remote bulk operations and management of coffee machines. Enables real-time monitoring and data analysis, optimizing operations and ensuring full control over each machine's performance.

Model	Power	Dimensions	Net Weight	Grinder	ES Brewer	Filter Brewer	Heating	Pump
JL300-ES7C	2800W	664 (W)*1855 (H)*720 (D)mm	150kg	PGH64 x 1	P14x1/P20 (optional)	—	Boiler x 1	Piston pump x 1
JL300-ESFB7C	2800W	664 (W)*1855 (H)*720 (D)mm	150kg	PGH64 x 1	P14x1/P20 (optional)	14g x 1 (tea)	Boiler x 1	Piston pump x 1
JL300-IN8C	2800W	664 (W)*1855 (H)*720 (D)mm	150kg	—	—	—	Boiler x 1	Piston pump x 1

Cup Delivery Door	Cup Number	Lid Number	Cup Specifications	Bean Hopper	Instant Canister	Drip Tray	Waste Bin
Cup Delivery Door	150	85	D90mm, 12 Oz 16 Oz (optional)	1.8kg x1	4L x 6	20L	140 cakes
Cup Delivery Door	150	85	D90mm, 12 Oz 16 Oz (optional)	1.8kg x1	4L x 6	20L	140 cakes
Cup Delivery Door	150	85	D90mm, 12 Oz 16 Oz (optional)	—	4L x 8	20L	—



JL500

CQC CE CB

Daily Output :
250 cups

Colors:
●

Optional Accessory:
BIB / Top Light Box



High-Performance Brewing System

Equipped with a high-performance P14 brewer (optional P20) and a 2700W storage boiler, ensuring efficient and stable 9-bar pressure and 92° C optimal extraction for premium coffee quality.



20+ Hot & Cold Beverage Options

Features a multi-canister design with a built-in chiller, capable of preparing over 20 types of hot and cold coffee and instant beverages.



27-Inch Touchscreen

Sleek and modern design with an intuitive 27-inch touchscreen for effortless operation provides a seamless and convenient coffee experience.

Model	Power	Dimensions	Net Weight	Grinder	ES Brewer	Filter Brewer	Heating	Pump
JL500-ES7C-PI	2700W	664 (W) *1855 (H) *720 (D) mm	150kg	Ditting EMH64 x1	P14x1/P20 (optional)	—	Boiler x 1	Gear pump x 1
JL500-ESFB7C-PI	2700W	664 (W) *1855 (H) *720 (D) mm	150kg	Ditting EMH64 x1	P14x1/P20 (optional)	14g x 1 (tea)	Boiler x 1	Gear pump x 1
JL500-IN8C-PI	2700W	664 (W) *1855 (H) *720 (D) mm	150kg	—	—	—	Boiler x 1	Piston pump x 1

Cup Delivery Door	Cup Number	Lid Number	Cup Specifications	Bean Hopper	Instant Canister	Drip Tray	Waste Bin
Manual cup delivery door	150-200	130 (90mm) optional	D80mm, 100z 90mm, 120z (optional)	1.5kg x 1	4L x 6	15L	125 cakes
Manual cup delivery door	150-200	130 (90mm) optional	D80mm, 100z 90mm, 120z (optional)	1.5kg x 1	4L x 6	15L	125 cakes
Manual cup delivery door	150-200	130 (90mm) optional	D80mm, 100z 90mm, 120z (optional)	—	4L x 8	15L	—



JL550

CQC CE CB

Daily Output:
250 cups

Colors:
●

Optional Accessory:
BIB / Top Light Box



Ditting Grinder

Features the Swiss Ditting EK7 grinder with 64mm flat burrs for even grinding. Made of impact-resistant special steel, it offers multi-stage grind size adjustment to meet various brewing needs.



Built-in Ice Maker

Equipped with powerful compressor and evaporator, this integrated system combines ice production and chilled water functions. With precise ice output control and a 1.5kg ice storage capacity, it ensures a continuous supply of ice for high-demand scenarios.



40 Hot & Cold Beverage Options

Featuring a multi-canister design with the option for a tea brewing function, capable of producing over 40 types of hot and cold beverages, providing a one-stop beverage solution with a diverse selection to meet varying taste preferences.

Model	Power	Dimensions	Net Weight	Grinder	ES Brewer	Filter Brewer	Heating	Pump
JL550-ES7C-PI	2800W	1000 (W)*1855 (H)*785 (D) mm	280kg	Ditting EK7 x 1	P14x1/P20 (optional)	—	Boiler x 1	Gear pump x 1
JL550-ESFB7C-PI	2800W	1000 (W)*1855 (H)*785 (D) mm	280kg	Ditting EK7 x 1	P14x1/P20 (optional)	14g x 1 (tea)	Boiler x 1	Gear pump x 1

Cup Delivery Door	Cup Number	Lid Number	Cup Specifications	Bean Hopper	Instant Canister	Drip Tray	Waste Bin
Cup Delivery Door	150	130	D90mm, 12 Oz 16 Oz (optional)	1.5kg x 1	4L x 6	15L direct drainage (optional)	125 cakes
Cup Delivery Door	150	130	D90mm, 12 Oz 16 Oz (optional)	1.5kg x 1	4L x 6	15L direct drainage (optional)	125 cakes



Enjoy a seamless self-service experience with diverse coffee flavors. Automatic cup dispensing and lid sealing ensure a touch-free, grab-and-go convenience. Smafi management and remote operation make high-quality coffee service effortless and efficient.



JL510

CQC CE CB

Daily Output:
250 cups

Colors:



Optional Accessory:
BIB / Top Light Box

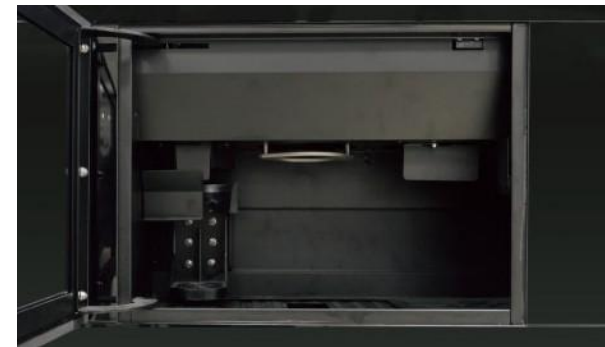

Automatic Cup Dispensing & Lid Capping

Automatic cup dispensing and lid capping, with smafi alefis for low cups/lids and missing cups/lids, improving operational speed and efficiency.



Automatic Timed Cleaning

Allows for scheduled automatic cleaning of the entire machine or specific components, reducing the risk of residue in the system and enhancing beverage hygiene and safety.



Remote Cloud Monitoring

Enables real-time monitoring of equipment status via mobile or computer, including instant mix levels, beverage sales, and troubleshooting, eliminating the need for on-site staff.

Model	Power	Dimensions	Net Weight	Grinder	ES Brewer	Filter Brewer	Heating	Pump
JL510-ES7C-PI-Y	2700W	664 (W)*1855 (H)*720 (D) mm	150kg	Ditting EMH64 x1	P14x1/P20 (optional)	—	Boiler x 1	Gear pump x 1
JL510-ESFB7C-PI-Y	2700W	664 (W)*1855 (H)*720 (D) mm	150kg	Ditting EMH64 x1	P14x1/P20 (optional)	14g x 1 (tea)	Boiler x 1	Gear pump x 1
JL510-IN8C-PI-Y	2700W	664 (W)*1855 (H)*720 (D) mm	150kg	—	—	—	Boiler x 1	Piston pump x 1

Cup Delivery Door	Cup Number	Lid Number	Cup Specifications	Bean Hopper	Instant Canister	Drip Tray	Waste Bin
Manual cup delivery door	150	130	D90mm, 16 Oz	1.5kg x 1	4L x 6	15L	125 cakes
Manual cup delivery door	150	130	D90mm, 16 Oz	1.5kg x 1	4L x 6	15L	125 cakes
Manual cup delivery door	150	130	D90mm, 16 Oz	—	4L x 8	15L	—



JL560

CQC CE CB

Daily Output:
250 cups

Colors:



Optional Accessory:
BIB / Top Light Box

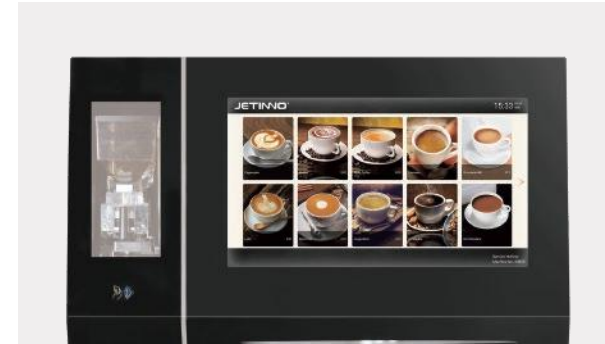

Grab & Go Contactless Experience

One-touch activation for automatic cup dispensing, cup placement, lid capping, and automatic lift door—fully automated operation, providing a completely contactless beverage experience.



Standardized Ice Beverage Output

Precise control over ice output and continuous ice production, ensuring each cup of iced coffee meets consistent standards and can handle high-volume demand during peak hours.



Visible Freshly Ground Coffee

The transparent glass panel in front of the coffee bean hopper and grinder allow customers to see the coffee beans being freshly ground, enhancing the sensory experience as they enjoy the rich aroma of every cup.

Model	Power	Dimensions	Net Weight	Grinder	ES Brewer	Filter Brewer	Heating	Pump
JL560-ES7C-PI-Y	2800W	1000 (W)*1855 (H)*785 (D) mm	280kg	Ditting EK7 x 1	P14x1/P20 (optional)	—	Boiler x 1	Gear pump x 1
JL560-ESFB7C-PI-Y	2800W	1000 (W)*1855 (H)*785 (D) mm	280kg	Ditting EK7 x 1	P14x1/P20 (optional)	14g x 1 (tea)	Boiler x 1	Gear pump x 1

Cup Delivery Door	Cup Number	Lid Number	Cup Specifications	Bean Hopper	Instant Canister	Drip Tray	Waste Bin
Cup Delivery Door	150	130	D90mm, 16 Oz	1.5kg x 1	4L x 6	15L direct drainage (optional)	125 cakes
Cup Delivery Door	150	130	D90mm, 16 Oz	1.5kg x 1	4L x 6	15L direct drainage (optional)	125 cakes



JL852

CQC CE CB

Daily Output :
300 cups

Colors:



Optional Accessory:
BIB / Top Light Box



Integrated Ice and Chilled Water System

Powerful ice making and storage capabilities, combined with instant cold water dispensing, ensuring efficient preparation of iced and chilled beverages.



Triple Boiler & Dual Pump System

Enhances both coffee extraction and milk frothing efficiency, while also improving the quality of fresh milk coffee. The dual systems work simultaneously to reduce customer wait time.



Smak Hot & Cold Fresh Milk Frothing

Professional milk pumps provide the foundation for producing thick, smooth hot and cold milk foam, supporting three different types of fresh milk to meet diverse consumer preferences.



Flavor Syrup Module

Supports 6 different syrup flavors, unlocking the potential for flavored coffee options. The intelligent syrup dispensing system allows for precise control of sweetness levels, satisfying a variety of taste preferences.



Model	Power	Dimensions	Net Weight	Grinder	ES Brewer	Filter Brewer	Heating	Pump
JL852-ESFB7C6S-FM-Y	3800W	1000 (W) * 1900 (H) * 1000 (D) mm	450kg	Ditting EMH64 x1 PGH64 (optional)	P14x1/P20 (optional)	14g x 1 (tea)	Boiler x 3	Vane pump x 1

Cup Delivery Door	Cup Number	Lid Number	Cup Size	Bean Hopper	Instant Canister	Drip Tray	Waste Bin
Cup Delivery Door	150	130	D90mm, 16 Oz, Opt. 12 Oz	1.8kg x1	4L x 6	20L direct drainage (optional)	125 cakes

ACCESSORIES

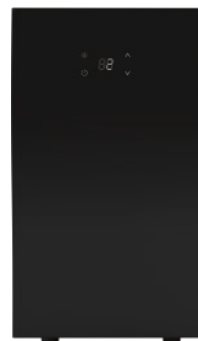

MC6D Milk Fridge

Voltage/Frequency:	220-240V 50/60Hz
Power:	48W
Temperature Range:	0~4° C
Refrigerant:	R600a/10.5g
Milk Box Capacity:	3.8L
Effective Volume:	6L
External Dimensions:	220 (W)*402 (H)*400 (D) mm
Internal Dimensions:	150 (W)*153 (H)*286 (D) mm
Weight:	12kg
Milk Position Alefi:	Yes



BR9CN Professional Milk Fridge

Voltage/Frequency:	220-240V 50/60Hz
Power:	60W
Temperature Range:	0~4° C
Refrigerant:	R600a/12g
Milk Box Capacity:	4.5L
Effective Volume:	8L
External Dimensions:	220 (W)*456 (H)*452 (D) mm
Internal Dimensions:	160 (W)*190 (H)*280 (D) mm
Weight:	14.1kg
Milk Position Alefi:	-



Brewing System Cleaning Tablets

Usage: For cleaning coffee machine brewers
Net Content: 2g per tablet, 100 tablets per bottle



Milk System Cleaning Tablets

Usage: For cleaning the milk system
Ratio: 1 tablet mixed with 500ml of water
Net Content: 4g per tablet, 120 tablets per bottle



Milk Tank

Capacity: 500ml
Height: 170mm
Diameter: 85mm
Weight: 159.4g