

STLB Sewing Team



FEDERAL PRODUCT CATALOG

2025

Our mission is to provide employment opportunities for people who are blind or visually impaired.

About Us

stlb™ has been changing the lives of individuals who are blind or visually impaired since 1964. Since its humble beginning at a small warehouse, the Lighthouse has grown from only three to nearly 200 employees; from a small building to a 140,000 square foot facility over seven acres, and from providing only brooms and mops, to providing a series of office products, military supplies, and services to government agencies.

We are one of the Largest Manufacturers of quality 3-ring binders in the United States. But size is not what we are all about. Quality is. We are ISO 9001:2000 Certified, an internationally recognized quality standard. It is our employees that make us different, from our customer service staff that will work with you to meet your needs to our competent and highly trained manufacturing staff. Here you'll find a dedicated and responsive organization.

We know that if you put your name on it, you want quality. So we use the finest materials we can find. Thanks to our efficient operation, we are able to combine top quality with some of the most competitive prices available.

We hope you will give us a chance to prove just how good we are!



A Message from Tim Hatch



Thank you for supporting stlb™! Just by taking the time to browse through this catalog and purchasing the products featured in the following pages you are helping to make a difference in the lives of our neighbors who are blind and visually impaired across South Texas and beyond!

stlb™ provides a wide spectrum of services. First, we are the premier employer of South Texans who are blind or visually impaired south of Houston and San Antonio. We operate two manufacturing plants, one in Corpus Christi and the other in Victoria, where our employees who are blind and visually impaired assemble office products, such as binders and index tabs and package supplies like toilet paper and cleaning products for state and federal agencies. We also assemble mail trays for the United States Postal Service and, through our sewing department, gloves for the military in both our production plants.

Our work doesn't stop there. We operate seven Base Supply Centers (BSC) on military installations from as far away as California and Hawaii! We sell the products that we manufacture along with products from any of the other 90 agencies across the country that employ those who are blind or visually impaired. In keeping with our mission to employ, educate and empower our neighbors who are blind and visually impaired, we afford those with vision loss the opportunity to gain valuable retail sales and customer service experience in each of our Base Supply Centers through employment opportunities. stlb™ assesses and fully provides all needed accommodations to our employees who are blind and visually impaired, showcasing their talents and abilities despite their disability.

Finally, stlb™ is a go-to resource for those with vision loss. Folks with issues related with vision loss can call in, and our team will refer them to the appropriate place where they can get the assistance they need, whether it be finding affordable and accessible housing, financial assistance for a sight saving procedure or training in using assistive technology and orientation and mobility skills for traveling independently. In addition, stlb™ operates a low vision store where individuals who are blind and visually impaired can purchase adaptive aids that can help them live a more independent and productive life. Some of the adaptive low vision products we sell include a variety of canes for people who are blind, talking watches and alarm clocks, bump dots and much more, all at reasonable prices!

All of this is possible with your continued support. As an individual who is visually impaired and has benefitted from all of the services that stlb™ has to offer, and who now serves as part of the team to help employ, educate and empower our neighbors who are blind and visually impaired, I could not be more thankful to all of those who make our work and mission possible.

Once again, thank you!

Tim Hatch

TABLE OF **CONTENT**

Binders.....	pg.05
CD/DVD Sleeves	pg.16
G-Pak	pg.17
Gloves	pg.19
Index Tabs	pg.24
Mouse Pads	pg. 26
Paper Bags	pg. 27
Sand Bags	pg. 28

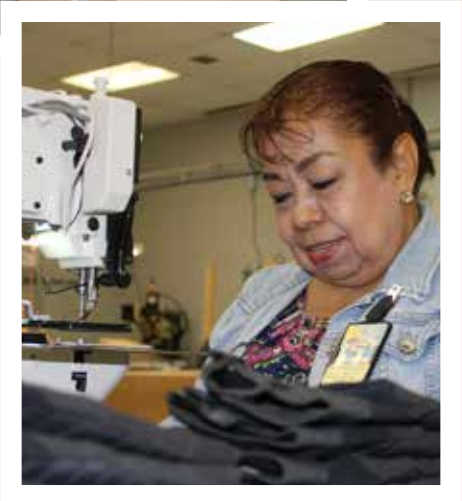

How To Order

By Email customer.service@stlb.net

By Mail: Sales Department
stlb™
P.O. Box 9697
Corpus Christi, TX 78469-9697

By Phone: 1-888-255-8011 x126, x137, x185

Many of the products are Ability One products and may be ordered through the following sources:

Government and Commercial Electronic

GSA Advantage! On-Line Shopping Service - GSA Advantage! is an Internet-based shopping service with millions of products and negotiated savings. Many of the most commonly used Ability One supplies are available through GSA Advantage and are identified with the Ability One logo. GSA, Ability One distributors, and www.abilityone.com offer competitive pricing and convenient delivery options. To browse or order, go to: www.gsaadvantage.gov.

Order by AbilityOne Authorized Distributors

You may purchase AbilityOne items through a number of other distribution channels: DOD Email (www.dla.mil) and through an authorized MAS (Multiple Awards Schedule) vendor: For a comprehensive list of MAS vendors, please go to the <http://www.abilityone.gov/distributors/index.html> website and click on "Current AbilityOne Authorized Distributors."

Order by AbilityOne Authorized Wholesalers

You may also order through the AbilityOne Authorized Wholesalers: Essendant (www.essendant.com) and SP Richards (www.sprichards.com)

Ability One Retail Locations (Base Supply Centers and More!)

The Ability One program operates Base Supply Centers on many military installations and some additional supply stores in Federal buildings. Also known as Self-Service Supply Stores or SERVMARTs, these convenient locations allow walk-in shopping, and in most cases, will deliver orders on base. Look for a wide range of Ability One products and other essentials items at each location.

Feel free to contact **stlb™** if you have any questions or comments.

For Sales/Customer Service:

1-888-255-8011 x126, x137, x185
customer.service@stlb.net

General Information:

361-883-6553
www.stlb.net

Index Tabs

Pre-Printed Tabs



Index tab dividers have become the standard for organization and presentations. With so many to choose from, we bring you not only great quality but assurance that with your support these tabs help support our mission. For your convenience they can be used with any laser or inkjet printer.

We have numerous versatile layouts that will be perfect for your next project. Not only do they look great but they are also made out of 30% post consumer material. You'll appreciate their contemporary style as well as being able to effectively retrieve all of your important information quickly. All while doing your part to help our environment.

Order Number	Product Description	Color/ Type
7530-01-368-3490	12-Tab, Jan - Dec	Multi-Color
7530-01-368-3492	26-Tab, A-Z	Multi-Color
7530-01-368-3489	10-Tab, 1-10	Multi-Color
7530-01-368-3493	31-Tab, 1-31	Multi-Color
7530-00-621-5258	12-Tab, 1-12	Multi-Color
7530-01-407-2250	25-Tab, 1-25 Legal Unpunched	White
7530-01-407-2248	25-Tab, 26-50 Legal Unpunched	White
7530-01-364-9489	5-Tab, 1-5	Multi-Color



Index Tabs

Index Maker Dividers

Produce print shop-quality documents at your desktop. Clear labels virtually disappear when applied to tabs. Creating tab labels for one or more divider sets is quick and easy with free Easy Apply™ Auto-Fill.

For laser and ink jet printers. Take advantage of the efficient, patented Easy Apply™ label strip that allows you to apply clear labels to all tabs all at once: simply print labels, align them against tabs, smooth down labels and peel the strip. Regardless of your line of business, Index Maker products help turn your written work and presentations into professional, print shop-quality documents in just a matter of minutes-right at your desk.

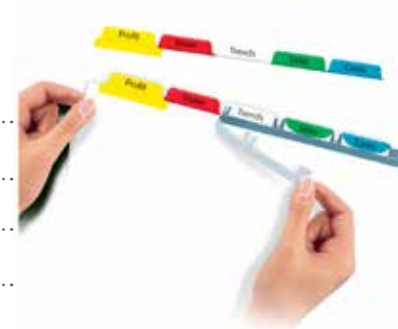

Templates available at avery.com/library.

Description

NSN

Index Maker, Multicolor, 8 tabs 1 set, AVE11407	7530-01-600-6970
Index Maker, White, 8 tab, 5 set	7530-01-600-6982
Index Maker, Multicolor, 5 tabs 1 set, AVE11406	7530-01-434-4198
Index Maker, White, 8 tabs 1 set, AVE11417	7530-01-600-6978
Index Maker, White, 5 tabs 1 set, AVE11416	7530-01-600-6977
Index Maker, White, 5 tabs 5 set, AVE11436	7530-01-600-6981

SKILCRAFT™ Big Tab Insertable Dividers

Big Tab Insertable Dividers offer 1.5 times more printed space on the tab inserts. Unique tab design keeps inserts from falling out. Reinforced holes provide extra tear-resistance. 11" side is three-hole punched. 8-1/2" x 11" set is great for everyday use.



Description

NSN

Skilcraft Big 8 Tab Insertable Dividers Buff Clear/White	7530-01-703-5694
Skilcraft Big 5 Tab Insertable Dividers White/Multi-Color	7530-01-703-0459

Round Ring Standard Binders



Nicholas Cordova III,
employee since 2016

Utilizing the best components in manufacturing, our 3-ring vinyl binders are some of the toughest in the industry. Anodized and strengthened O rings that won't mis-align or open at the wrong time. Heavy duty vinyl that will not tear at the slightest catch. Pockets that hold those extra papers snug. Employees who are particular about and proud of their workmanship. All these are what make our vinyl binders work to keep your material where it needs to be: bound together.

They come in a variety of colors. The ring capacity shown is the maximum number of 20 lb. bond sheets that each binder will hold.

Ring Capacity based on 20lb. bond sheets

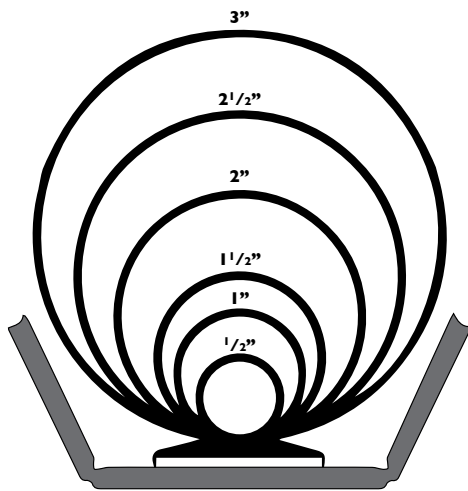

Ring Size	Round Ring
1/2"	100
1"	175
1 1/2"	280
2"	375
2 1/2"	475
3"	575

Colors: 

Case Quantity Quick Chart

Ring Size	Case Qty	Cases/Pallet	CS weight lbs.	EA/Pallet
1/2"	18	22	18	396
1"	18	18	20	324
1 1/2"	12	27	18	324
2"	12	18	21	216
2 1/2"	6	27	13	162
3"	6	27	13	162
4"	6	18	15	108

Round Ring Binder w/Pockets



Size	Color	NSN
1/2"	White	7510-01-STB-1000
1/2"	Black	7510-01-STB-1001
1/2"	Blue	7510-01-STB-1002
1/2"	Red	7510-01-STB-1003
1/2"	Gray	7510-01-STB-1004
1/2"	Green	7510-01-STB-1007
1/2"	Yellow	7510-01-STB-1011
1"	White	7510-01-510-7492
1"	Black	7510-01-278-4131
1"	Blue	7510-00-409-8646
1"	Red	7510-00-409-8647
1"	Gray	7510-00-782-2663
1"	Green	7510-01-STB-1018
1"	Yellow	7510-01-STB-1022
1 1/2"	White	7510-01-STB-1023
1 1/2"	Black	7510-01-STB-1024
1 1/2"	Blue	7510-01-STB-1025
1 1/2"	Red	7510-01-STB-1026
1 1/2"	Gray	7510-01-STB-1027
1 1/2"	Green	7510-01-STB-1030
1 1/2"	Yellow	7510-01-STB-1034

2"	White	7510-01-STB-1035
2"	Black	7510-01-278-4130
2"	Blue	7510-01-431-6236
2"	Red	7510-01-431-6244
2"	Gray	7510-01-STB-1039
2"	Green	7510-01-STB-1042
2"	Yellow	7510-01-STB-1046
2 1/2"	White	7510-01-STB-1047
2 1/2"	Black	7510-01-STB-1048
2 1/2"	Blue	7510-01-STB-1049
2 1/2"	Red	7510-01-STB-1050
2 1/2"	Gray	7510-01-STB-1051
2 1/2"	Green	7510-01-STB-1054
2 1/2"	Yellow	7510-01-STB-1058
3"	White	7510-01-STB-1059
3"	Black	7510-01-278-4129
3"	Blue	7510-01-510-4873
3"	Red	7510-01-511-4322
3"	Gray	7510-01-511-4320
3"	Green	7510-01-STB-1065
3"	Yellow	7510-01-STB-1069

Round Ring Standard Presentation Binders



Joe Nerio,
employee since 2013

Utilizing the best components in manufacturing, our 3-ring vinyl Presentation binders are some of the toughest in the industry. Anodized and strengthened O rings that won't mis-align or open at the wrong time. Heavy duty vinyl that will not tear at the slightest catch. Pockets that hold those extra papers snug. Employees who are particular about and proud of their workmanship. All these are what make our vinyl binders work to keep your material where it needs to be: bound together.

They come in a variety of colors. The ring capacity shown is the maximum number of 20 lb. bond sheets that each binder will hold.

Ring Capacity based on 20lb. bond sheets

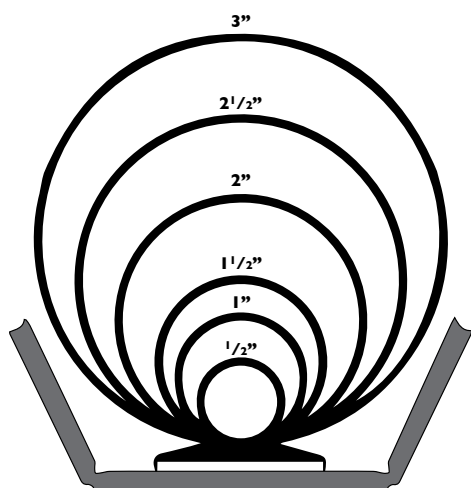

Ring Size	Round Ring
1/2"	100
1"	175
1 1/2"	280
2"	375
2 1/2"	475
3"	575

Colors:

Case Quantity Quick Chart

Ring Size	Case Qty	Cases/Pallet	CS weight lbs.	EA/Pallet
1/2"	18	22	18	396
1"	18	18	20	324
1 1/2"	12	27	18	324
2"	12	18	21	216
2 1/2"	6	27	13	162
3"	6	27	13	162
4"	6	18	15	108

Round Ring Binder w/Pockets & Overlay



Size	Color	NSN
1/2"	White	7510-01-510-4859
1/2"	Black	7510-01-283-5274
1/2"	Blue	7510-01-510-4860
1/2"	Red	7510-01-425-6139
1/2"	Gray	7510-01-STB-1074
1/2"	Green	7510-01-STB-1077
1/2"	Yellow	7510-01-STB-1081
1"	White	7510-01-203-4708
1"	Black	7510-01-510-4865
1"	Blue	7510-01-510-4869
1"	Red	7510-01-STB-1084
1"	Gray	7510-01-STB-1085
1"	Green	7510-01-STB-1088
1"	Yellow	7510-01-STB-1092
1 1/2"	White	7510-01-519-4381
1 1/2"	Black	7510-01-STB-1094
1 1/2"	Blue	7510-01-519-4382
1 1/2"	Red	7510-01-519-4383
1 1/2"	Gray	7510-01-519-4376
1 1/2"	Green	7510-01-519-4363
1 1/2"	Yellow	7510-01-STB-1104

2"	White	7510-01-203-8814
2"	Black	7510-01-283-5273
2"	Blue	7510-01-STB-1107
2"	Red	7510-01-STB-1108
2"	Gray	7510-01-STB-1109
2"	Green	7510-01-431-6239
2"	Yellow	7510-01-STB-1116
2 1/2"	White	7510-01-STB-1117
2 1/2"	Black	7510-01-STB-1118
2 1/2"	Blue	7510-01-STB-1119
2 1/2"	Red	7510-01-STB-1120
2 1/2"	Gray	7510-01-STB-1121
2 1/2"	Green	7510-01-STB-1124
2 1/2"	Yellow	7510-01-STB-1128
3"	White	7510-01-510-4866
3"	Black	7510-01-510-4871
3"	Blue	7510-01-510-4858
3"	Red	7510-01-STB-1132
3"	Gray	7510-01-STB-1133
3"	Green	7510-01-272-3231
3"	Yellow	7510-01-STB-1140

Slant D-Ring Standard Presentation Binders



**Curtis Prince,
employee since 1999**

Utilizing the best components in manufacturing, our 3-ring vinyl binders are some of the toughest in the industry. Anodized and strengthened Slant D rings that won't misalign or open at the wrong time. Heavy duty vinyl that will not tear at the slightest catch. Pockets that hold those extra papers snug. Employees who are particular about and proud of their workmanship. All these are what make our vinyl binders work to keep your material where it needs to be: bound together.

They come in a variety of colors. The ring capacity shown is the maximum number of 20 lb. bond sheets that each binder will hold.

Ring Capacity based on 20lb. bond sheets

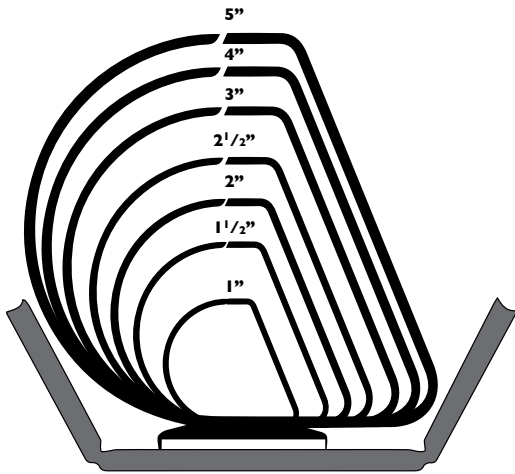

Ring Size	Slant D-Ring
1"	220
1 1/2"	350
2"	480
2 1/2"	575
3"	700
4"	890
5"	1270

Colors:

Case Quantity Quick Chart

Ring Size	Case Qty	Cases/Pallet	CS weight lbs.	EA/Pallet
1/2"	18	22	18	396
1"	18	18	20	324
1 1/2"	12	27	18	324
2"	12	18	21	216
2 1/2"	6	27	13	162
3"	6	27	13	162
4"	6	18	15	108

Slant D-Ring Binder w/Pockets & Overlay



Size	Color	NSN
1"	White	7510-01-384-8786
1"	Black	7510-01-420-8078
1"	Blue	7510-01-417-1881
1"	Red	7510-01-417-1879
1"	Gray	7510-01-STB-1145
1"	Green	7510-01-STB-1148
1"	Yellow	7510-01-STB-1152
1 ½"	White	7510-01-385-6711
1 ½"	Black	7510-01-STB-1154
1 ½"	Blue	7510-01-417-1882
1 ½"	Red	7510-01-417-1877
1 ½"	Gray	7510-01-STB-1157
1 ½"	Green	7510-01-STB-1160
1 ½"	Yellow	7510-01-STB-1164
2"	White	7510-01-384-8788
2"	Black	7510-01-STB-1166
2"	Blue	7510-01-417-1884
2"	Red	7510-01-417-1878
2"	Gray	7510-01-STB-1169
2"	Green	7510-01-STB-1172
2"	Yellow	7510-01-STB-1176

2 ½"	White	7510-01-384-8673
2 ½"	Black	7510-01-STB-1178
2 ½"	Blue	7510-01-417-1883
2 ½"	Red	7510-01-417-1876
2 ½"	Gray	7510-01-STB-1181
2 ½"	Green	7510-01-STB-1184
2 ½"	Yellow	7510-01-STB-1188
3"	White	7510-01-368-3486
3"	Black	7510-01-412-6338
3"	Blue	7510-01-368-3487
3"	Red	7510-01-368-3485
3"	Gray	7510-01-STB-1193
3"	Green	7510-01-STB-1196
3"	Yellow	7510-01-STB-1200
4"	White	7510-01-STB-1400
4"	Black	7510-01-STB-1401
4"	Blue	7510-01-STB-1402
4"	Red	7510-01-STB-1403
4"	Gray	7510-01-STB-1404
4"	Green	7510-01-STB-1407
4"	Yellow	7510-01-STB-1411
5"	Black	7510-01-392-5283

Recycled Binders

100% Recycled & Recyclable Turned Edge Binder-D Ring on back Cover



Colors:

With the green movement filtering down to everyday lives, **stlb™** has come up with not only a recycled binder but a 100% Recyclable binder. Once the binder is too worn to continue its use, instead of throwing it away, you can recycle the whole binder! It only takes but a minute to separate the rings from the binder, and when that is finished, just recycle accordingly. They come in three great colors with a leather grain finish, and several different sizes with D-rings that can hold 20% more paper than regular round rings. It helps us do everything we can to preserve the environment while providing a professional looking binder that doesn't look like it's recycled.

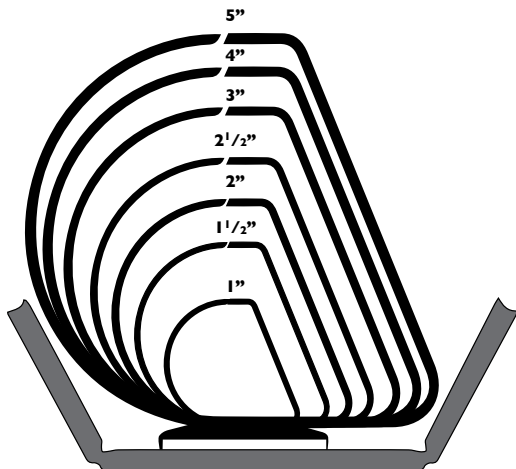

Recycled and Recyclable

Size	Color	NSN
1"	Black	7510-01-579-9329
1"	Blue	7510-01-579-9318
1"	Green	7510-01-579-9326
1 1/2"	Black	7510-01-579-9315
1 1/2"	Blue	7510-01-579-9321
1 1/2"	Green	7510-01-579-9328
2"	Black	7510-01-579-9317
2"	Blue	7510-01-579-9324
3"	Black	7510-01-579-9319
3"	Blue	7510-01-579-9325

100% Recycled*

Size	Color	NSN
1"	Black	7510-00-281-6180
2"	Black	7510-00-530-8881

*Non-removable rings located on spine

Poly Binders

Round Ring Poly Binder

The poly binder is lightweight, flexible and extremely durable. They are great for outdoor, indoor use, and industrial environments. They resist water, oil, grease, and dirt. Ideal for record keeping. They are available in two colors, blue and white.



Colors:

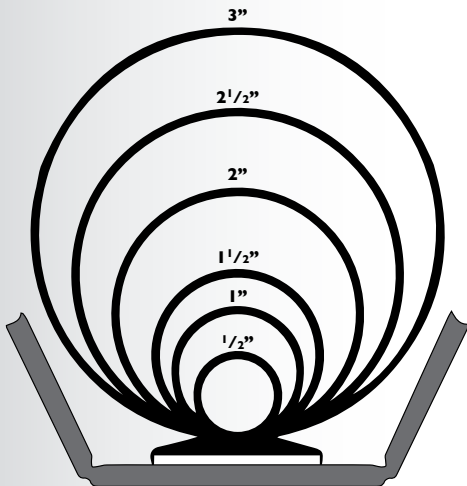

Size	Color	NSN
1/2"	White	7510-01-484-1761
1/2"	Blue	7510-01-484-1757
1"	White	7510-01-484-1759
1"	Blue	7510-01-484-1763
1 1/2"	White	7510-01-484-1744
1 1/2"	Blue	7510-01-484-1742
2"	White	7510-01-484-1743
2"	Blue	7510-01-484-1745

Specialty Binders

Round Ring Camouflage Binder w/ Pockets



Size	Color	NSN
1/2"	Camo	7510-01-484-1754
1"	Camo	7510-01-484-1755
1 1/2"	Camo	7510-01-484-1762
2"	Camo	7510-01-STB-1600
3"	Camo	7510-01-STB-1601

Miscellaneous Binders



Type	NSN
1/2" Black Round Ring Flexible Binder	7510-00-984-5787
1 1/2" USAF Technical Manual	7510-00-241-4958
1" Pocket Appointment Book	7510-00-285-1765
1" Round Ring Turned Edge Binder, Black	7510-00-281-6180
2" Round Ring Turned Edge Binder, Black	7510-00-530-8881
4" Slant D-3 Ring Binders W/Pockets, w/Overlay, White	7510-01-495-0696
5" Slant D-3 Ring Binders W/Pockets, w/no Overlay, Black	7510-01-392-5283
2" Rigid Hinge Turned Edge Binder, Black	7510-00-579-2751

Frame View Binders

PVC Framed View Binders

- Vinyl framed front cover and spine
- 2 clear inside pockets with business card holder
- Made with 45% recycled post consumer material
- Notched insert sheets help the placement of cover materials for presentation ready results



Colors:



Size	Color	NSN
1/2"	Black	7510-01-462-1384
1/2"	Navy	7510-01-462-1383
1/2"	White	7510-01-462-1387
1"	Black	7510-01-462-1390
1"	Navy	7510-01-462-1388
1"	White	7510-01-462-1386
1 1/2"	Black	7510-01-462-1389
1 1/2"	Navy	7510-01-462-1385
1 1/2"	White	7510-01-462-1391
2"	Black	7510-01-703-5692
2"	White	7510-01-703-4466
3"	Black	7510-01-703-5693
3"	White	7510-01-703-5695

CD/DVD Sleeves

Paper and Plastic



Even a small scratch could significantly damage a CD or DVD, so protect your discs with our sleeves. We have white paper sleeves and white plastic sleeves. Our paper sleeves have a window cut out, so you can always see what it contains and a back flap to provide security that helps it from falling out in transit. Our plastic sleeves have the capacity of holding two CD's and have 5 holes for the capability of inserts and/or binding.



Style	NSN
(100 pack) Paper Sleeves White	7510-01-STB-2000
(100 pack) Plastic Sleeves White	7510-01-STB-2103

G-PAK

G-PAK Packing System

Introducing the future of packing and shipping! The G-PAK is a durable, reusable, advanced packing system. It is a RDB-Rapid Deployment Box, but is also great for all your storage needs. It is 100% reusable and 100% recyclable.

Stop wasting money on products for packing and shipping that you will have to dispose of after only one use. The G-PAK is stackable, weatherproof, and also collapses so that you can stack for future use or ship them back efficiently and resourcefully. Save space and re-use them over and over again. It has a built in pallet, drain holes, and is able to be lifted from all sides. (Forklift & Pallet Jack Ready!) The G-PAK can store up to 3000 lbs. Don't waste money anymore on supplies that can only be utilized one time. Go green, save money, and be a part of the future of packing and shipping!



Size	Dimensions	NSN
Standard	48x40x36	8115-01-582-9711
Small	48x32x26	8115-01-582-9709
Medium	48x32x34	8115-01-582-9708
Large	48x32x50	8115-01-582-9710



G-PAK

G-Sleeve



This unit works with...
Plastic Top NSN 8115-01-444-0211
Plastic Bottom 8115-01-444-0206

The G-Sleeve is a very durable, strong, collapsible and reusable pallet sleeve. A better alternative to the flimsy cardboard sleeve that you may have seen laying around your warehouse or motor-pool. The G-Sleeve is made of 58% recycled polypropylene and is built to last.

- No more weather damage
- No more waste
- Reusable and Lightweight
- Durable and Collapsible
- Flame retardant & washable



Order Number	Product Description	Size in.	U/I
8115-01-598-2717	G-Sleeve Small	48x40x30	EA
8115-01-598-2716	G-Sleeve Large	48x40x45	EA

Gloves

Assortment of High Quality Gloves

Your hands are the most valuable and utilized part of your body. But they are also the most vulnerable. We bring you the right gloves for the right job so that you can protect your hands. We have various gloves that are specifically designed for the dangers and risks encountered in several different circumstances. We only use select materials and pride ourselves in our top quality work that is put in the making of every one of our gloves. Each glove is meticulously made and sewn in accordance to ISO 9001:2000 standards. Choose from our selection of gloves for your needs and rest easy in the knowledge that your hands are well protected.



Mario Garcia,
employee since 1993



Impact



Flyer's



Work



Mechanic's

Flyer's Gloves

Flyer's Glove Nomex (Berry compliant)



Colors:

Color	Size	NSN
Sage Green	4	8415-01-482-8417D
Sage Green	5	8415-01-040-2012D
Sage Green	6	8415-01-040-1453D
Sage Green	7	8415-01-029-0109D
Sage Green	8	8415-01-029-0111D
Sage Green	9	8415-01-029-0112D
Sage Green	10	8415-01-029-0113D
Sage Green	11	8415-01-029-0116D
Sage Green	12	8415-01-482-8420D
Desert Tan	5	8415-01-461-4920D
Desert Tan	6	8415-01-461-4922D
Desert Tan	7	8415-01-461-4924D
Desert Tan	8	8415-01-461-4932D
Desert Tan	9	8415-01-461-4934D
Desert Tan	10	8415-01-461-4940D
Desert Tan	11	8415-01-461-4942D
Desert Tan	12	8415-01-482-8690D
Black	4	8415-01-482-8678D
Black	5	8415-01-461-4962D
Black	6	8415-01-461-4964D
Black	7	8415-01-461-4966D
Black	8	8415-01-461-4969D
Black	9	8415-01-461-4970D
Black	10	8415-01-461-4971D
Black	11	8415-01-461-4981D
Black	12	8415-01-482-8684D

Impact Control Gloves

Anti-Static Impact Control Gloves

- Breathable area between fingers must allow for air flow
- Padded knuckle panel capable of providing flexibility with abrasion and impact resistance
- Touch Screen Capable
- Snug fitting 2-way stretch padded top with conductive anti-static properties
- TAA Compliant
- Sold in Packs of 5 Pairs



Color	Sizes	NSN
Black	Extra Small	8415-01-610-7322
Black	Small	8415-01-610-7325
Black	Medium	8415-01-610-7323
Black	Large	8415-01-610-7324
Black	Extra Large	8415-01-610-7326
Black	Extra Extra Large	8415-01-610-7327

Mechanic's Gloves

Mechanic's Gloves (AbilityOne & TAA Compliant)



Color	Size	NSN
Black	S	8415-01-497-5381
Black	M	8415-01-497-5384
Black	L	8415-01-497-5989
Black	XL	8415-01-497-5987
Black	XXL	8415-01-501-1557

Impact Gloves

Impact Gloves (Korean, TAA Compliant)



Color	Size	NSN
Black	S	8415-01-497-7265K
Black	M	8415-01-498-4964K
Black	L	8415-01-498-8180K
Black	XL	8415-01-498-4966K
Black	XXL	8415-01-498-4968K

Work Gloves

Split Leather Work Gloves (China)

Color	Size	NSN
Beige/Brn	X-Small / size 1	8415-00-268-7871
Beige/Brn	Small/ size 2	8415-00-268-7872
Beige/Brn	Medium/ size 3	8415-00-268-7869
Beige/Brn	Large/size 4	8415-00-268-7870
Beige/Brn	X-Large/size 5	8415-00-268-7868



Jersey Knit Work Glove

Color	NSN
Brown	8415-09-STB-4109



Mouse Pads

Standard Mouse Pads

As one of the most popular computer accessories, the mouse pad is brought to you in either our three standard colors or your chosen artwork. We have blue, red and gray that come packed individually or in an assorted three-pack. For greater impact we can customize them with an image of your choice. Our four color process allows for a permanent high resolution imprint that won't fade.

These mouse pads don't just look professional but are made to last: they are backed with heavy duty natural rubber that eliminates skid and has a resilient polyester surface that provides excellent traction.

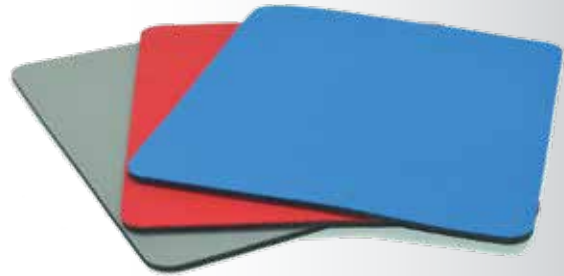

Colors:   

**Great Color Reproduction + Great Traction +
Your Custom Message=1 Great Mouse Pad**

Description	NSN
Red	7045-01-368-4808
Blue	7045-01-368-4809
Gray	7045-01-368-4810
Assorted 3 pack (blue, gray, & red)	7045-01-368-4811

**Custom Mousepads are also available upon request. Minimum order 1 case of 12.
NSN #: 7045-01-STB-6000**

Paper Bags

Large Variety of Styles



- Are made from a renewable natural resource
- Can be reused again and again
- Are biodegradable
- Available in a wide variety of sizes and strengths

Paper Bag Size	UPC/NSN	Paper Bag Size	UPC/NSN
Heavy weight, 1 LB size 30lbs. 8 M/Bale	76955720676	Extra Heavy Duty, Nail, 10 LB size 500/Bale	76955720805
2# Paper Bag 4 ¹ / ₄ x 2 ³ / ₈ x 8 ¹ / ₈ " 6 M/Bale	8105-00-281-1158	12# Paper Bag 13.875 x 7" 1 M/Bale	8105-00-271-1485
Heavy weight, 4 LB size 4 M/Bale	76955720683	Heavy weight, 16 LB size 50 lbs weight 500/Bale	76955696612
5# Paper Bag 5.25 x 10.75 x 3.375" 3 M/Bale	8105-00-281-1163	20# Paper Bag 8 ¹ / ₈ x 6 x 14 ³ / ₈ " 1 M/Bale	8105-00-266-7308
Heavy weight, 6 LB size 2 M/Bale	76955738954		
Heavy weight, 8 LB size 40 lbs weight 1 M/Bale	76955720799	Extra Heavy Duty Utility, 25 LB size 1 M/Bale	76955696780
8# Paper Bag 6 ¹ / ₄ x 3 ³ / ₄ x 12 ³ / ₄ " 400/Bale	8105-00-281-1425	25# Paper Bag 17.875 x 8.25" 1 M/Bale	8105-00-281-1429
Heavy weight, 10 LB size 2 M/Bale	76955721086	Lawn and Leaf Bag, heavy duty, 50 bags/bale 16 x 12 x 35, 30 gallon capacity	76955716550
1/6 Paper Bag 12 x 7 x 16.5" 400/Bale	8105-00-022-1319	Burn Bag 17 x 13 x 7" Red & White stripes 250/Bale	8105-00-262-7363
1/2# Paper Bag 3x1 ³ / ₈ " 10 M/Bale	8105-00-281-1156	1/4 Paper Bag 23.25 x 11 x 7" 250/Bale	8105-00-543-7169
1/8 Paper Bag 9 ³ / ₄ x 6 ¹ / ₄ x 16 ³ / ₈ " 500/Bale	8105-00-579-9161		
Heavy Weight, 2 lb size- 50weight 3 M/BALE	076955738855	Heavy Weight, 5lb size 2,000/Bale	076955720690
Heavy Weight, 8lb size 2,000/Bale	076955720065	Heavy Weight, 12lb size 1,000/Bale	076955696605
Heavy Weight, 25lb size 500/Bale	076955696650		

Sand Bags

Sand Bags



Always be prepared for any eventuality in this ever changing environment! Our Sand Bags are top notch with high quality and durable construction. Rest easy in knowing that when you need a sand bag to perform, ours will surpass the needed and expected results with flying colors.

Description	NSN
White Polypropylene - 17"x27"	7510-01-STB-2007
Digital Camo Polypropylene - 17"x27"	8105-01-568-1328

Notes

Notes

Notes

More than 25 million Americans are living with vision loss

Thank you for your order! Your patronage helps us to fulfill our mission and serve our Employees who are visually impaired or blind.



For Sales/Customer Service:
1-888-255-8011 x126, x137, x185
customer.service@stlb.net

General Information:
361-883-6553



4421 Agnes Street
Corpus Christi, TX 78405
www.stlb.net

last updated 9/24