

ANTRACITA

por EDAA

CATÁLOGO 2024

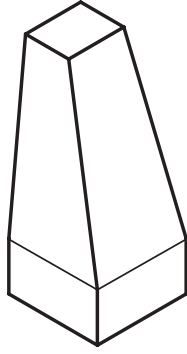



Antracita exhibe la cualidad material de la madera antes que sus posibilidades como materia prima. Es un ejercicio siempre en constante cambio basado en un módulo labrado que puede disponerse y repetirse en infinitas posibilidades para generar formas y paisajes, y objetos utilitarios. Las formas generadas por dicho módulo en repetición apuntan a una dialéctica entre la condición inerte del material y su forma sutil de sugerir movimiento perpetuo.

Antracita es una pieza modular de madera sólida de pino.
18.5 x 18.5 x h 45 cm.

Acabados: madera quemada con la técnica Shou Sugi Ban y acabada con barniz de poliuretano o madera natural acabada con aceite de linaza.

Antracita exhibits the natural traits of wood before its possibilities as a raw material. It is an ever-changing object based on a wood module that can be arranged and repeated in infinite possibilities to create forms and landscapes, and utilitarian objects. The arrangements created by this repeating module lead to a dialectic between the inert condition of the material and its subtle way of implying perpetual motion.

Antracita is a modular piece made of solid pine wood.
7.3 x 7.3 x h 17.8 in.

Finishes: charred wood using the Shou Sugi Ban technique and finished with polyurethane varnish or natural wood with a linseed oil finish.

CONTENIDO

- 08. Proceso de manufactura
- 10. Lo Sublime por Alratito Studio.
Art Week 2023 CDMX
- 16. No se Vende por Casa Miami, Galería Errante y
Alratito Studio. Art week 2024 CDMX
- 18. Inédito
Design Week 2022. Espacio CDMX
- 22. Zona Maco México Arte Contemporáneo por
Heart Ego y Strata. CDMX 2022
- 24. Objetos Arquitectónicos por Capitaes Gallery.
Art Week 2022 CDMX
- 26. Pabellón EDAA+Firenze.
Habitat Expo 2023. CDMX
- 30. Dancing Meridians por Alratito Studio y
Polina Stroganova. CDMX 2023
- 32. Catálogo de piezas
- 34. Sobre el creador

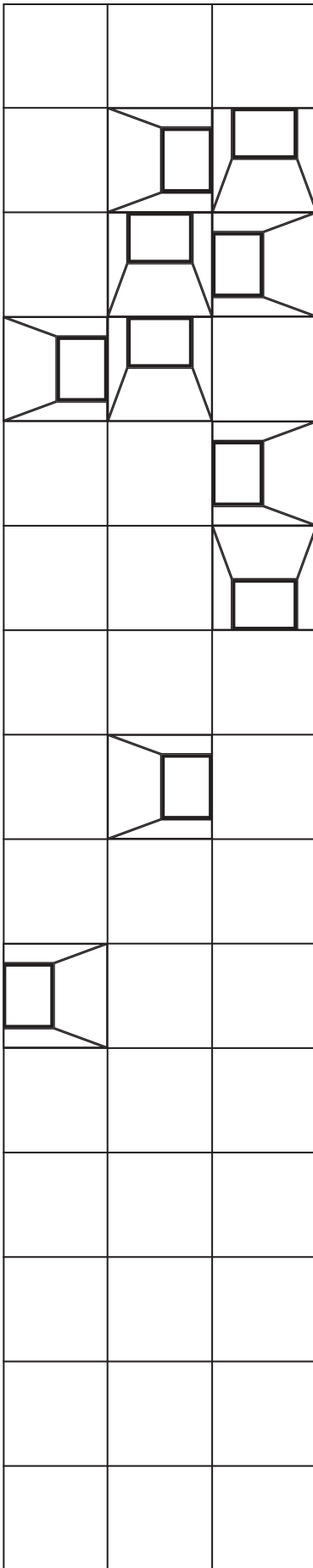

La madera se transforma en una pieza de arte-objeto.

La madera en bruto se trabaja mediante un proceso manual de carpintería rectificando cada pieza, haciendo cortes geométricos y labrando sus ensamblajes para después ser sometida a un proceso de acabado con fuego, utilizando la técnica ancestral japonesa Shou Sugi Ban.

Antracita, como pieza de arte-objeto, busca la intersección del material, irregular por naturaleza, con los procesos manuales de manufactura, siempre imperfectos, para generar un cambio al modo de alquimia: sin agregar ningún elemento adicional, el fuego transforma la superficie de la madera en carbón pero sin borrar su origen orgánico.

La versatilidad de la madera permite que las piezas puedan tener dos opciones de acabados: uno al natural acabado con aceite y otro acabado con fuego.

Wood is transformed into an art object.

The raw wood undergoes a manual woodworking process, rectifying each piece, making geometric cuts, and carving its assemblies in order to be subjected to a finishing process with fire using the ancestral Japanese technique called Shou Sugi Ban.

Antracita, as an art object, seeks the convergence of wood —irregular by nature— with the manufacturing processes —always imperfect— to generate change comparable to Alchemy: where without the addition of external elements fire transforms the surface of wood into carbon while preserving its organic origin.

The versatility of wood allows for two finishing options: natural wood with a linseed oil finish, or with a charred finish.

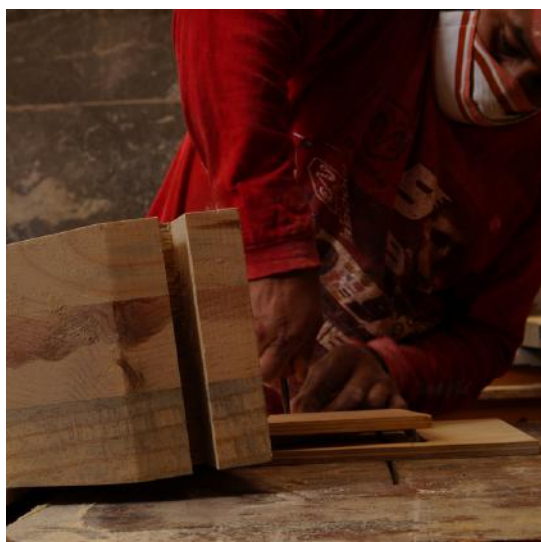

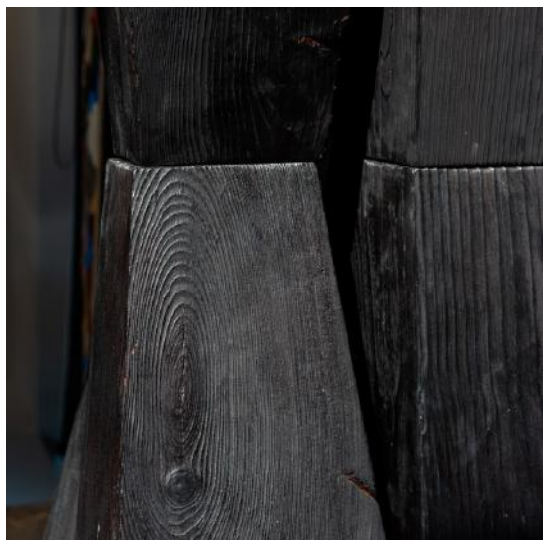

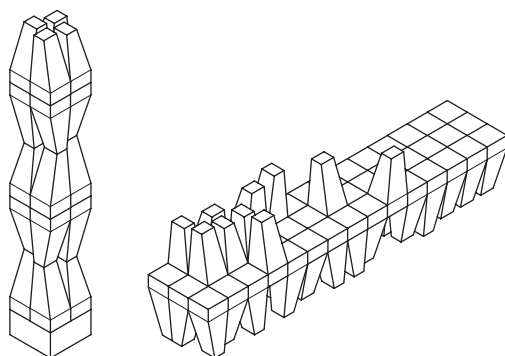

**LO SUBLIME
POR ALRATITO STUDIO
ART WEEK 2023 CDMX**



Antracita Banca

Medidas generales:
55.50 x 277.50 x h 45 cm
Número de módulos: 45

Materiales: madera sólida de pino quemada con la técnica Shou Sugi Ban y acabada con barniz de poliuretano.

Exhibición: Lo Sublime por Alratito Studio. Art Week 2023 CDMX

Dimensions:
21.90 x 109.30 x h 17.80 in
Number of modules: 45

Materials: solid pine wood charred with the Shou Sugi Ban technique and finished with polyurethane varnish.

Exhibition: Lo Sublime by Alratito Studio. Art Week 2023 Mexico City





Lo Sublime

"Whatever is in any sort terrible or is conversant about terrible objects or operates in a manner analogous to terror, is a source of the sublime," British philosopher Edmund Burke wrote.

In other words, without terror, there cannot be sublimity.

Antracita Tótem

Medidas generales:
37 x 37x h 245 cm
Número de módulos: 20

Materiales: madera sólida de pino quemada con la técnica Shou Sugi Ban y acabada con barniz de poliuretano. Base de concreto con hidrofugante.

Exhibición: Lo Sublime por Alratito Studio. Art Week 2023 CDMX

Dimensions:
14.60 x 14.60 x h 96.50 in
Number of modules: 20

Materials: solid pine wood charred with the Shou Sugi Ban technique and finished with polyurethane varnish. Concrete base with waterproof sealant.

Exhibition: Lo Sublime by Alratito Studio. Art Week 2023 Mexico City



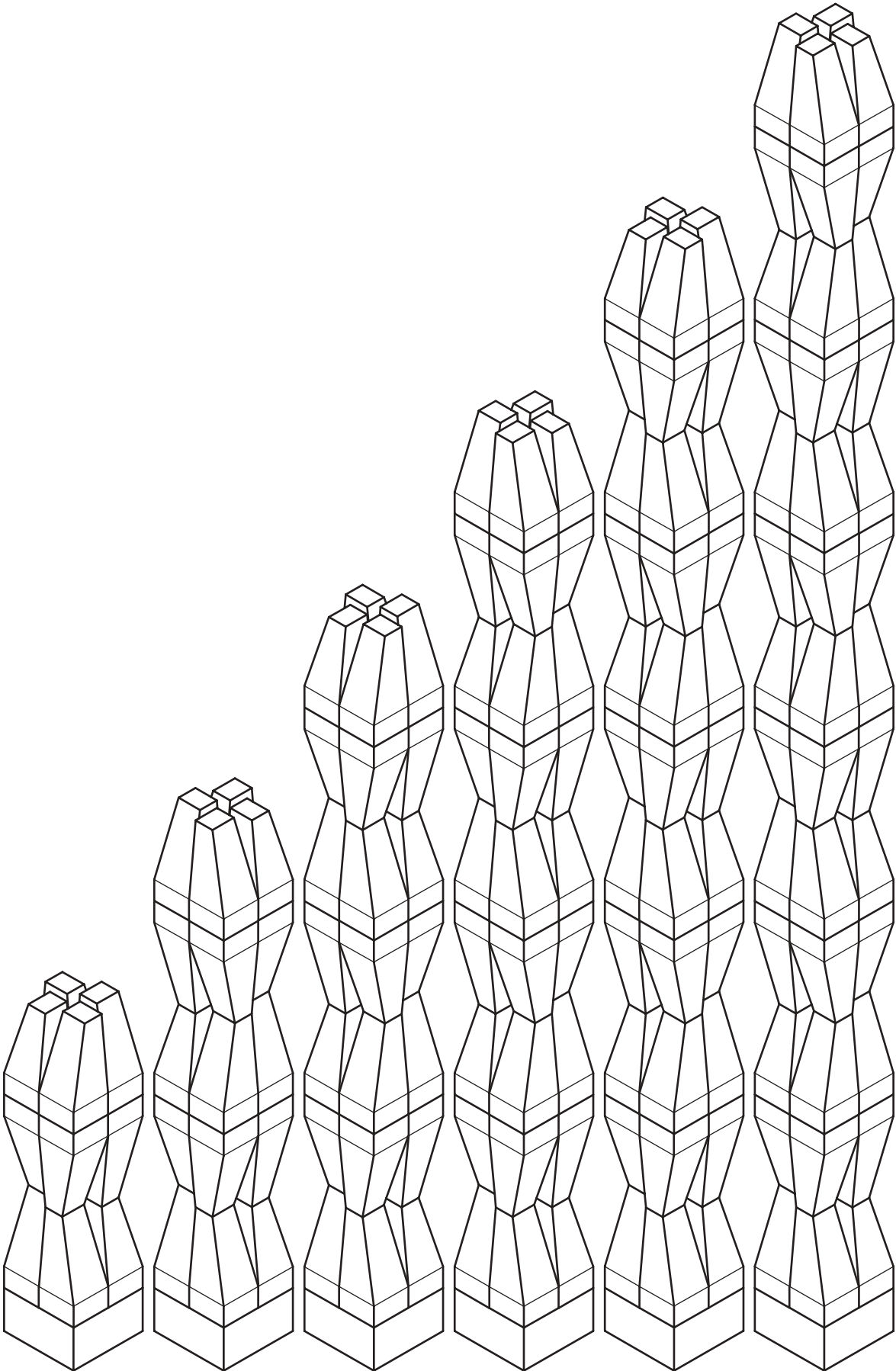

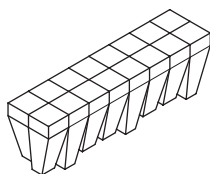
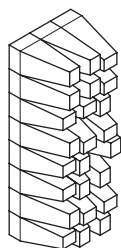

**NO SE VENDE
POR CASA MIAMI, GALERÍA ERRANTE
Y ALRATITO STUDIO
ART WEEK 2024 CDMX**

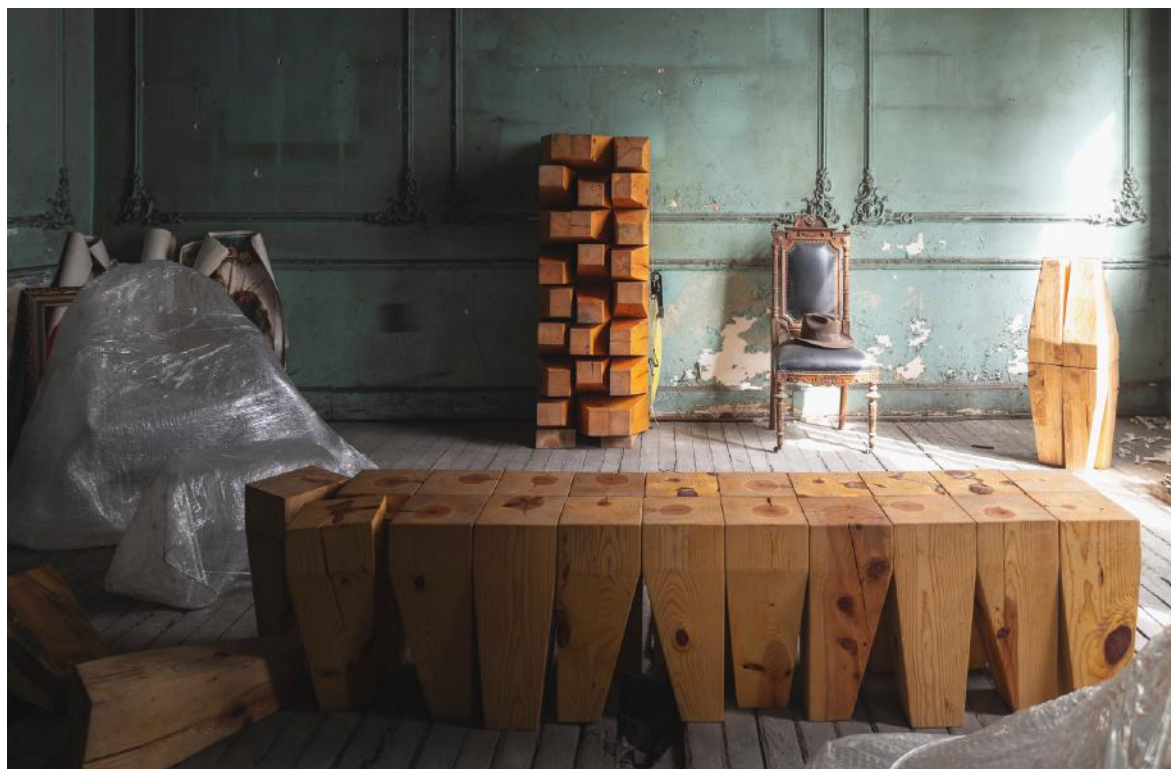

Antracita Banca et al.

Medidas generales:
37 x 148 x h 45 cm
Número de módulos: 20

Materiales: madera sólida de pino
acabada con aceite de linaza.

Exhibición: No se vende por Casa
Miami, Galería Errante y Alratito
Studio. Art Week 2024 CDMX

Dimensions:
14.60 x 58.30 x h 17.80 in
Number of modules: 20

Materials: solid pine wood, sanded,
and finished with linseed oil.

Exhibition: No se vende by Casa
Miami, Galería Errante, and Alratito
Studio. Art Week 2024 Mexico City

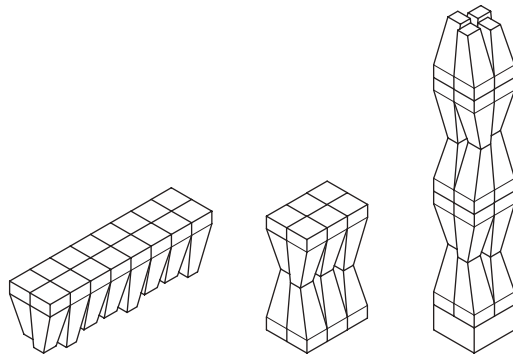
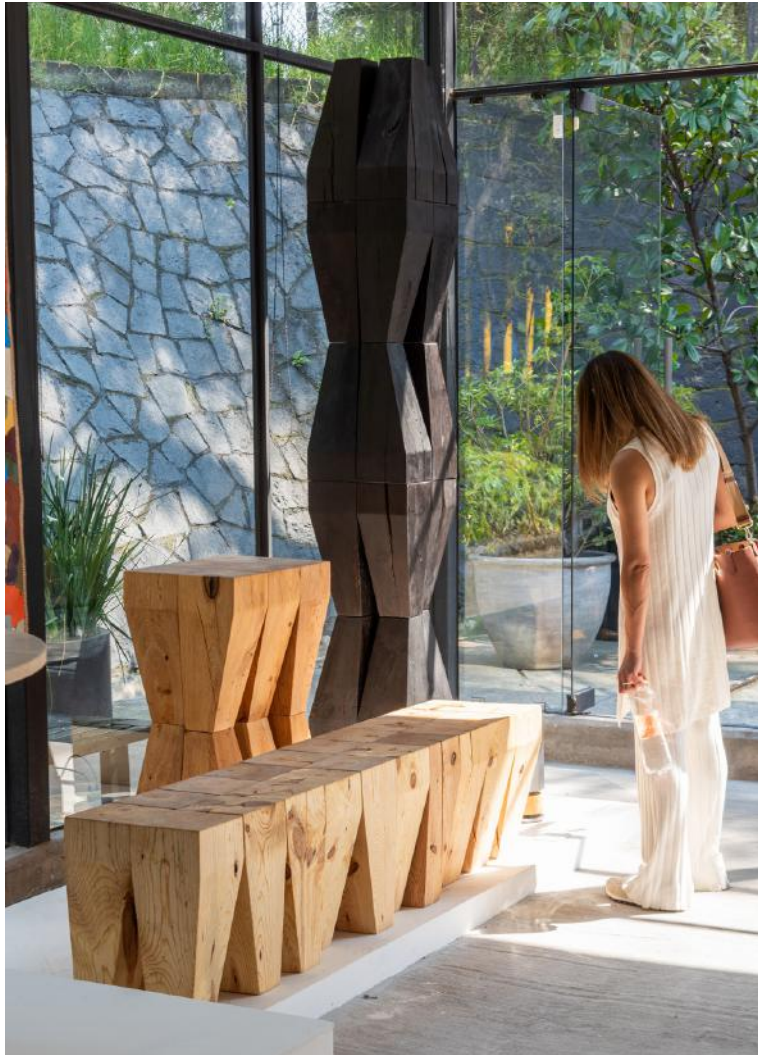

INÉDITO
DESIGN WEEK 2022
ESPACIO CDMX



Antracita Banca

Medidas generales:
37 x 148 x h 45 cm
Número de módulos: 20

Materiales: madera sólida de pino
acabada con aceite de linaza.

Exhibición: Inédito
Design Week 2022. Espacio CDMX

Dimensions:
14.60 x 58.30 x h 17.80 in
Number of modules: 20

Materials: solid pine wood, sanded,
and finished with linseed oil.

Exhibition: Inédito
Design Week 2022. Espacio CDMX
Mexico City



Antracita Mesa de apoyo

Medidas generales:
37 x 55.5 x h 90 cm
Número de módulos: 12

Materiales: madera sólida de pino
acabada con barniz de poliuretano.

Exhibición: Inédito
Design Week 2022. Espacio CDMX

Dimensions:
14.60 x 21.90 x h 35.40 in
Number of modules: 12

Materials: solid pine wood, sanded,
and finished with linseed oil.

Exhibition: Inédito
Design Week 2022. Espacio CDMX,
Mexico City



Antracita Tótem

Medidas generales:
37 x 37 x h 245 cm
Número de módulos: 20

Materiales: madera sólida de pino quemada con la técnica Shou Sugi Ban y acabada con barniz de poliuretano. Base de concreto con hidrofugante.

Exhibición: Inédito
Design Week 2022. Espacio CDMX

Dimensions:
14.60 x 14.60 x h 96.50 in
Number of modules: 20

Materials: solid pine wood charred with the Shou Sugi Ban technique and finished with polyurethane varnish. Concrete base with waterproof sealant.

Exhibition: Inédito
Design Week 2022. Espacio CDMX.
Mexico City

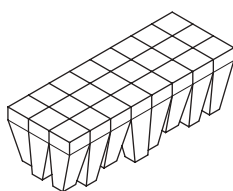
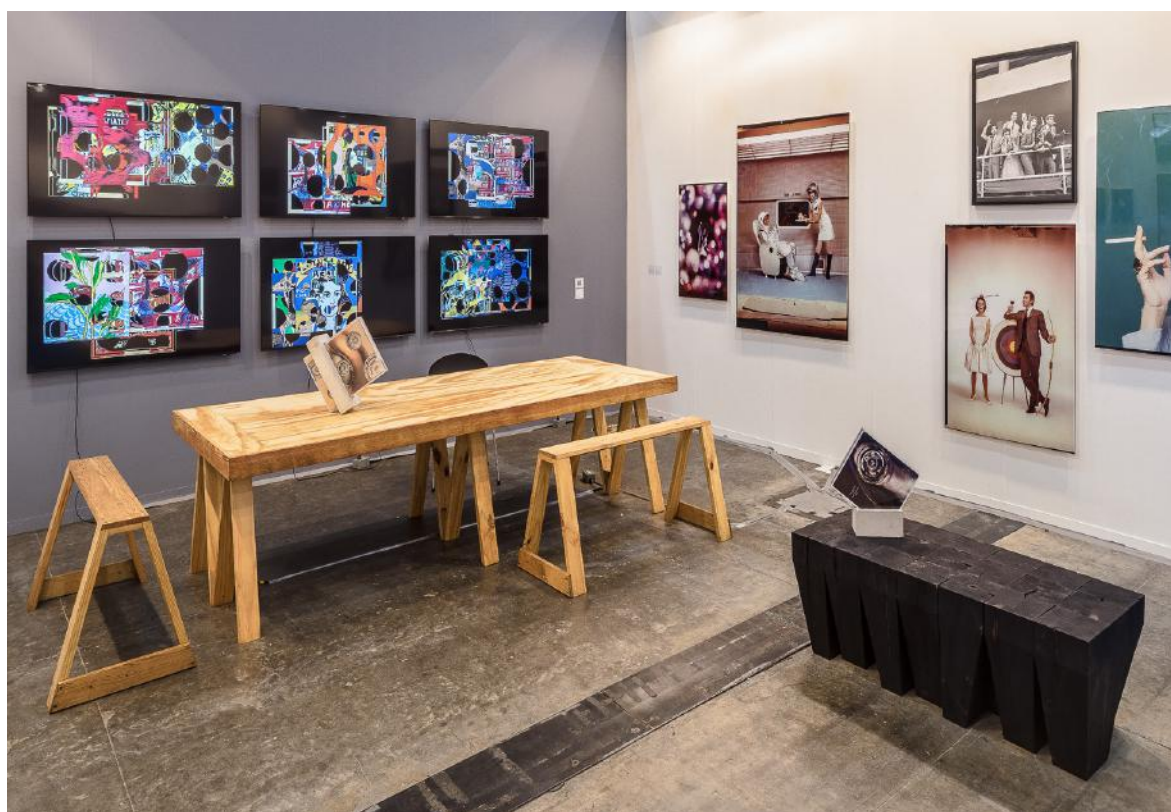

**ZONA MACO
MÉXICO ARTE CONTEMPORÁNEO
POR HEART EGO Y STRATA
CDMX 2022**



Antracita Banca

Medidas generales:
55.50 x 277.50 x h 45 cm
Número de módulos: 45

Materiales: madera sólida de pino quemada con la técnica Shou Sugi Ban y acabada con barniz de poliuretano.

Exhibición: Zona Maco México Arte Contemporáneo por Heart Ego y Strata. CDMX 2022

Dimensions:
21.90 x 109.30 x h 17.80 in
Number of modules: 45

Materials: solid pine wood charred with the Shou Sugi Ban technique and finished with polyurethane varnish.

Exhibition: Zona Maco México Arte Contemporáneo by Heart Ego and Strata. Mexico City 2022

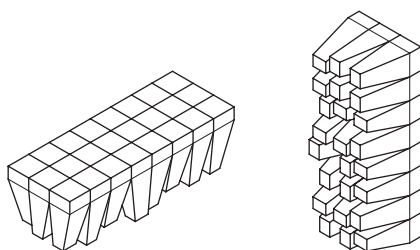

**OBJETOS ARQUITECTÓNICOS
POR CAPITALES GALLERY
ART WEEK 2022 CDMX**



Antracita Vertical

Medidas generales:
45 x 148 x h 55.50 cm
Número de módulos: 24

Materiales: madera sólida de pino
acabada con aceite de linaza.

Exhibición: Objetos Arquitectónicos
por Capitales Gallery. Art Week
2022 CDMX

Dimensions:
17.80 x 58.30 x h 21.85 in
Number of modules: 24

Materials: solid pine wood, sanded,
and finished with linseed oil.

Exhibition: Objetos Arquitectónicos by
Capitales Gallery. Art Week
2022 Mexico City

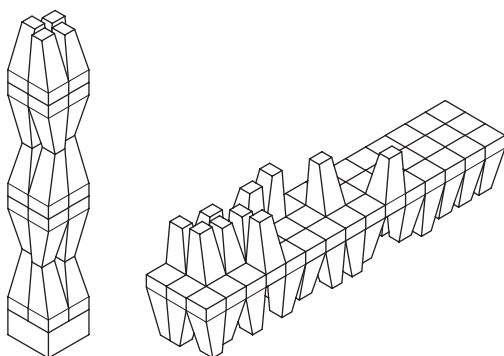

**PABELLÓN EDAA+FIRENZE
HABITAT EXPO 2023
CDMX**



Antracita Tótem

Medidas generales:
37 x 37 x h 245 cm
Número de módulos: 20

Materiales: madera sólida de pino quemada con la técnica Shou Sugi Ban y acabada con barniz de poliuretano. Base de concreto con hidrofugante.

Exhibición: Pabellón EDAA+Firenze. Habitat Expo 2023. CDMX

Dimensions:
14.60 x 14.60 x h 96.50 in
Number of modules: 20

Materials: solid pine wood charred with the Shou Sugi Ban technique and finished with polyurethane varnish. Concrete base with waterproof sealant.

Exhibition: EDAA+Firenze Pavilion. Habitat Expo 2023. Mexico City



Antracita Banca

Medidas generales:
55.50 x 277.50 x 45 cm
Número de módulos: 45

Materiales: madera sólida de pino quemada con la técnica Shou Sugi Ban y acabada con barniz de poliuretano.

Exhibición: Pabellón EDAA+Firenze.
Habitat Expo 2023. CDMX

Dimensions:
21.90 x 109.30 x 17.80 in
Number of modules: 45

Materials: solid pine wood charred with the Shou Sugi Ban technique and finished with polyurethane varnish.

Exhibition: EDAA+Firenze Pavilion.
Habitat Expo 2023. Mexico City

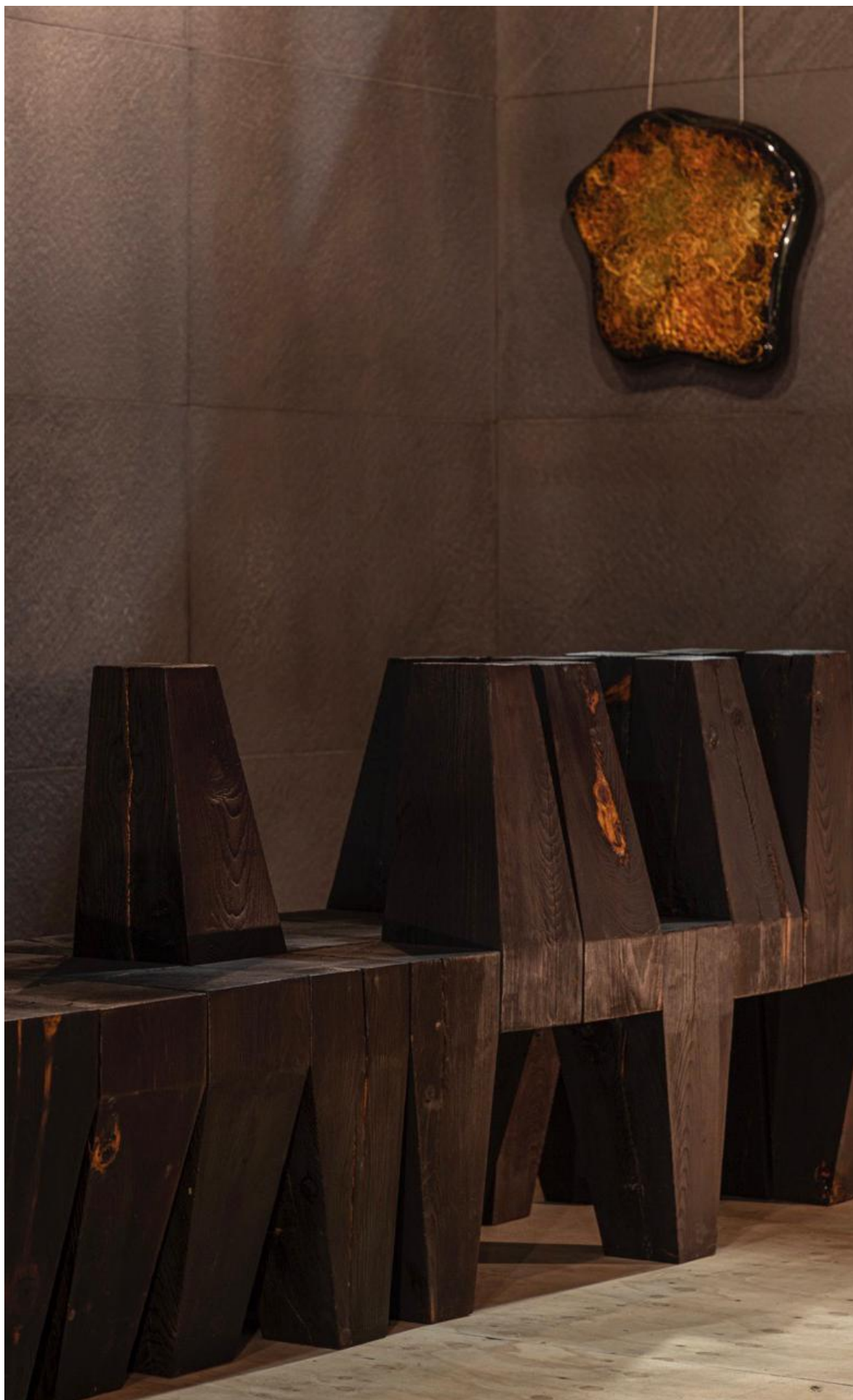

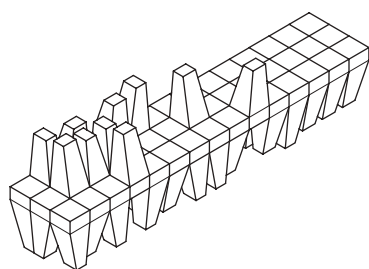
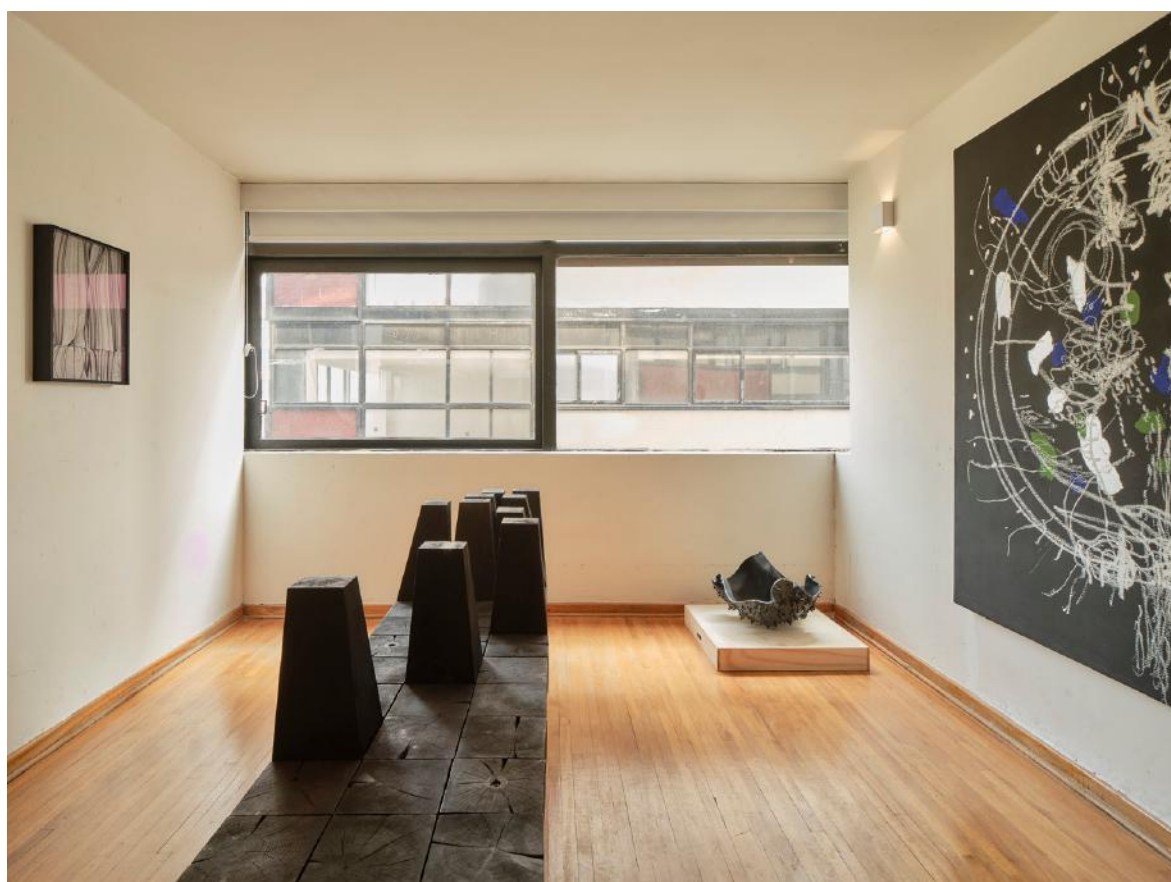

**DANCING MERIDIANS
POR ALRATITO STUDIO
Y POLINA STROGANOVA
CDMX 2023**

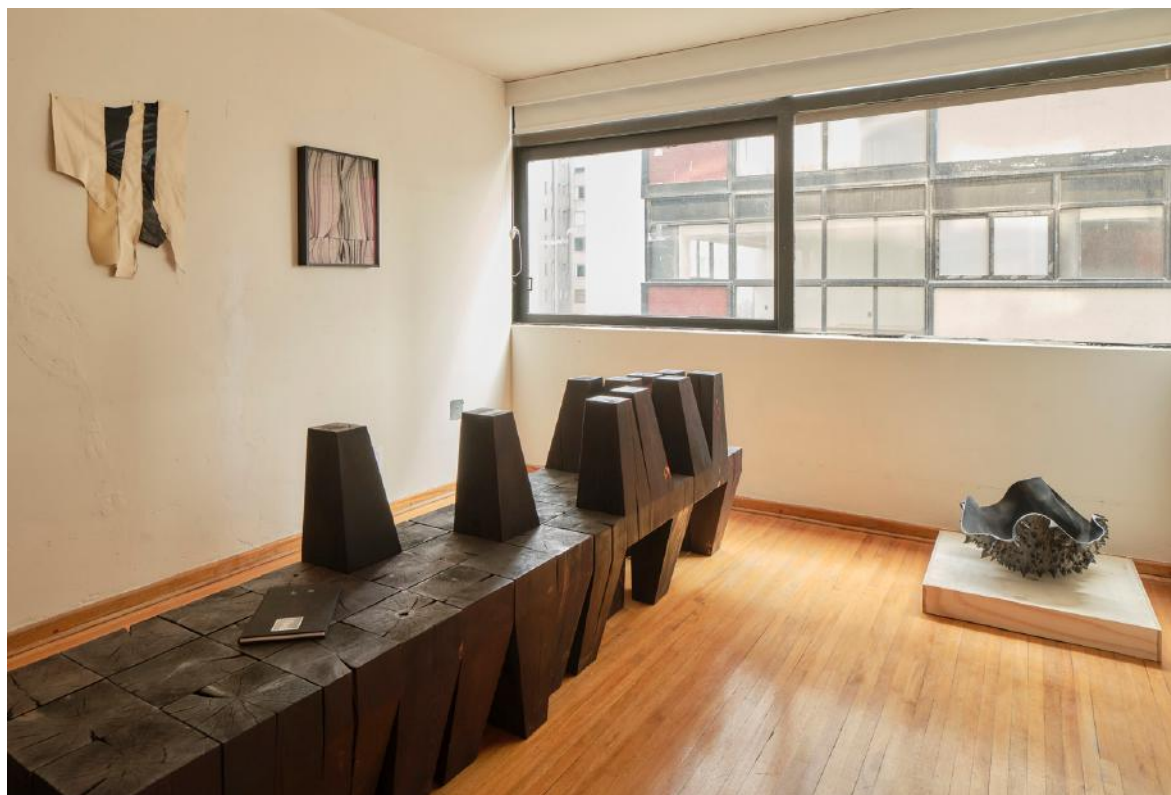

Antracita Banca

Medidas generales:
55.50 x 277.50 x h 45 cm
Número de módulos: 45

Materiales: madera sólida de pino quemada con la técnica Shou Sugi Ban y acabada con barniz de poliuretano.

Exhibición: Dancing Meridians por Alratito Studio y Polina Stroganova. CDMX 2023

Dimensions:
21.90 x 109.30 x h 17.80 in
Number of modules: 45

Materials: solid pine wood charred with the Shou Sugi Ban technique and finished with polyurethane varnish.

Exhibition: Dancing Meridians by Alratito Studio, and Polina Stroganova. Mexico City 2023

CATÁLOGO DE PIEZAS

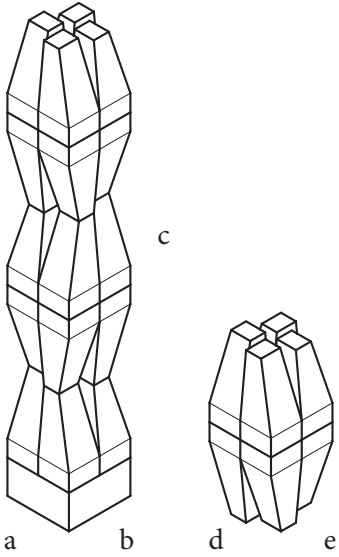

Antracita Tótem

Medidas generales: a 37, b 37, c 245 cm
Número de módulos: 20

Medidas generales: d 37, e 37, f 90 cm
Número de módulos: 8

Dimensions: a 14.60, b 14.60, c 96.50 in
Number of modules: 20

Dimensions: d 14.60, e 14.60, f 35.40 in
Number of modules: 8

Antracita Mesa de apoyo

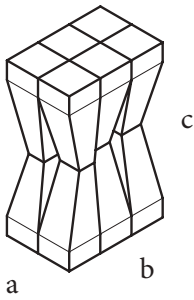

Medidas generales: a 37, b 55.5, c 90 cm
Número de módulos: 12

Dimensions: a 14.60, b 21.90, c 35.40 in
Number of modules: 12

Antracita Banca

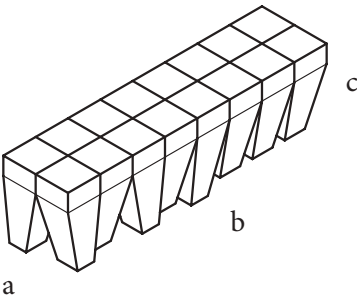

Medidas generales: a 37, b 148, c 45 cm
Número de módulos: 20

Dimensions: a 14.60, b 58.30, c 17.80 in
Number of modules: 20

Todas las piezas se pueden modificar por pedido al agregar o eliminar módulos de Antracita.

Materiales: madera sólida de pino.

Opciones de acabados: (i) quemada con la técnica Shou Sugi Ban y acabada con barniz de poliuretano, (ii) madera natural acabada con aceite de linaza.

Upon request, all pieces can be customized by adding or removing Antracita modules.

Materials: solid pine wood.

Finishing options: (i) charred with the Shou Sugi Ban technique and finished with polyurethane varnish, (ii) sanded wood finished with linseed oil.

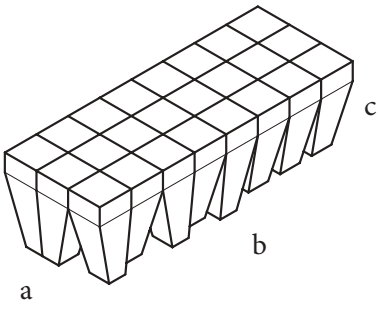

Antracita Blanca

Medidas generales: a 55.50, b 148, c 45 cm
Número de módulos: 24

Dimensions: a 21.90, b 58.30, c 17.80 in
Number of modules: 24

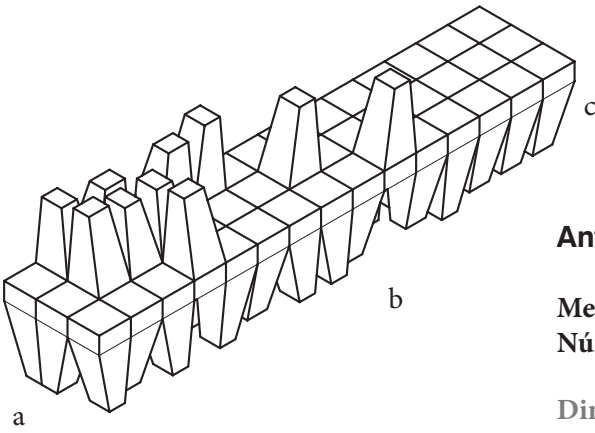

Antracita Blanca

Medidas generales: a 55.50, b 277.50, c 45 cm
Número de módulos: 45

Dimensions: a 21.90, b 109.30, c 17.80 in
Number of modules: 45

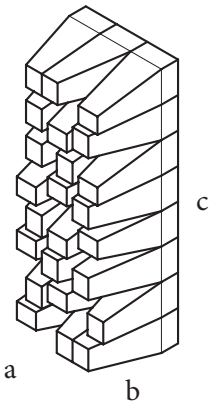

Antracita Vertical

Medidas generales: a 55.50, b 45, c 148 cm
Número de módulos: 24

Dimensions: a 21.85, b 17.80, c 58.30 in
Number of modules: 24

Todas las piezas se pueden modificar por pedido al agregar o eliminar módulos de Antracita.

Materiales: madera sólida de pino.

Opciones de acabados: (i) quemada con la técnica Shou Sugi Ban y acabada con barniz de poliuretano, (ii) madera natural acabada con aceite de linaza.

Upon request, all pieces can be customized by adding or removing Antracita modules.

Materials: solid pine wood.

Finishing options: (i) charred with the Shou Sugi Ban technique and finished with polyurethane varnish, (ii) sanded wood finished with linseed oil.

SOBRE EL CREADOR



Luis Arturo García es un arquitecto mexicano y fundador de EDAA (CDMX, 2007), una firma de arquitectura, diseño, producción de objetos y construcción. Inspirado en el cine y la literatura, las estrategias para el desarrollo arquitectónico se convierten en un pretexto, un dispositivo para generar narrativas de vida en su entorno inmediato, antes de cualquier consideración formal. Así mismo, funda junto con el artista multidisciplinario japonés Yupica, el colectivo EDAA+Yupica, el cual se adentra en conceptos espacio-temporales a través de prácticas transdisciplinarias en arquitectura, instalaciones de video, arte visual y sonoro; así como la producción de objetos.

El trabajo de EDAA ha sido reconocido nacional e internacionalmente a través de diversos premios. Entre sus logros destacados y recientes se encuentra la Mención de Honor al prestigioso Premio Golden Trezzini Awards en Rusia en 2022 y 2023, la Mención de Honor en la IV Bienal de Diseño de Iluminación de Iberoamérica en México en 2022, y en 2018 la Mención de Honor en los Architecture Master Prize en Los Angeles, CA, EEUU. Anteriormente, el estudio ganó la Medalla de Oro del Premio Internacional Dedalo Minosse en Vicenza, Italia en 2017 y fue nominado para el Premio Mies Crown Hall Americas Prize en Chicago, EEUU, en 2016. A nivel nacional, EDAA se destacó al obtener la Medalla de Oro en la Primera Bienal de Jóvenes Arquitectos (FCARM) en México en 2015 con la cual se nominó para su participación en el Premio Oscar Niemeyer para la Arquitectura Latinoamericana en el 2016, por mencionar algunos.

Luis Arturo García is a Mexican architect and founder of EDAA (Mexico City, 2007), an architecture, design, object production, and construction firm. Inspired by cinema and literature, the architectural development strategies become an excuse and trigger to create life narratives in their immediate surroundings before any formal considerations. In addition, he founded the collective EDAA+Yupica, together with multidisciplinary Japanese artist Yupica. The collective addresses the concepts of time and space through interdisciplinary practices in architecture, video installations, sound and visual art, and the production of objects.

The work of EDAA has gained international and national recognition through various awards. Among its most prominent and recent achievements is the Honorable Mention for the prestigious Golden Trezzini Awards in Russia in 2022 and 2023, the Honorable Mention at the IV Ibero-American Lighting Design Biennial in Mexico in 2022, and the Honorable Mention at the Architecture MasterPrize in Los Angeles, CA, USA in 2018. The firm formerly won the Gold Medal of the International Dedalo Minosse Award in Italy in 2017 and was nominated for the Mies Crown Hall Americas Prize in Chicago, USA, in 2016. National awards and recognitions include the Gold Medal at the First Biennial of Young Architects (FCARM) in Mexico in 2015, with which the firm was nominated for its participation at the Oscar Niemeyer Prize for Latin American Architecture in 2016 just to mention a few.

Créditos

Antracita

Diseño: Luis Arturo García, Juan Hernández
Supervisión y logística: Hans Álvarez
Manufactura: Hugo Hernández, Manuel Espindola
Transporte: Oficina Cobalto

Editorial

Dirección: Luis Arturo García
Diseño editorial: Luis Arturo García, Hans Álvarez, Karina Caballero.
Corrección de estilo: Emilse Tartabini
Traducción: Emilse Tartabini, Hans Álvarez

Fotografía	PP.
Christian Morales	16, 17
Gabriela Cardona	8, 9
Hans Álvarez	24, 25
Jaime Navarro Soto	3, 9-11, 13, 14, 18-21, 26-29, 34
Sergio López	12, 30, 31
Studio Chirika	22, 23

Arte

Anna Virnich	31
Christine N. Eyer	30, 31
Coco Brun	14
Desconocido	24
Galia Eibenschutz	30, 31
Héctor Falcón	22, 23
Kaucyila Brooke	10
Martin Soto Clement	30, 31
Mobiliario EDAA	22, 26, 27
Mutable Studio	13
Nuria López Torres	10
Tufic Yazbek	22, 23
Yupica	26, 29

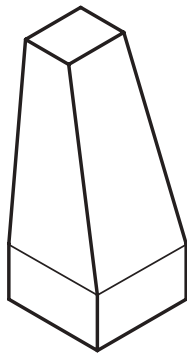

ig: edaa.mx
www.edaa.mx

Ciudad de México

