



Polaris Introduces  
**THE ALL-NEW TAYLOR-DUNN TT-416**



The most ergonomic tow tractor in its class.



65 Years of  
Vehicle Innovation



70 Years of  
Industrial Reliability

## ALL-NEW **TT-416** STAND UP TOW TRACTOR

Polaris introduces the Taylor-Dunn TT-416, the industry's only tow tractor with full front and rear suspension, and largest operator compartment in its class. The **TT-416** delivers the reliability and performance you'd expect from Taylor-Dunn, all the ingress and egress benefits of a stand-up, but in the most ergonomic package ever offered in its class.

**5' x 5'**  
Aisle Turning

**36-Volt**  
AC Motor

**16,000 LB**  
Towing



Largest Operator  
Compartment

Only Tug with Front &  
Rear Suspension

# ENGINEERED IN PARTNERSHIP WITH MAJOR MANUFACTURERS TO OPTIMIZE...



## SAFETY

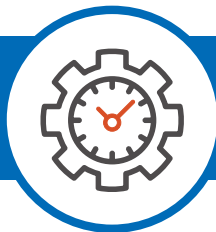

## LABOR EFFICIENCY



## PRODUCTIVITY



Safety Headlights and  
Large Front Push Bumper



350 LB Capacity  
Operator Compartment



Two Sided Emergency  
Shut Off Buttons



Easy Access  
Battery Compartment



Control Panel with Battery Meter,  
Horn, Hi-Low Speed Switch



Front Dual Coil Suspension and Rear  
Coil Suspension with Shock Absorbers

**PERFORMANCE**

|                             |                                                                                          |
|-----------------------------|------------------------------------------------------------------------------------------|
| <b>DRAWBAR PULL</b>         | 320 lb / 1.4kN                                                                           |
| <b>MAX SPEED (UNLOADED)</b> | 7 mph / 11.3 km/h                                                                        |
| <b>TURNING RADIUS</b>       | 60 in / 152.4 cm                                                                         |
| <b>TOW CAPACITY</b>         | 14,000 lb / 6,350 kg at 7mph (Equipped)<br>16,000 lb / 7,257 kg at 6mph (Factory Option) |

**DIMENSIONS**

|                         |                                |
|-------------------------|--------------------------------|
| <b>OVERALL LENGTH</b>   | 102 in / 259 cm                |
| <b>OVERALL WIDTH</b>    | 40.5 in / 103 cm               |
| <b>OVERALL HEIGHT</b>   | 87 in / 221 cm (with Lightbar) |
| <b>WHEEL BASE</b>       | 41 in / 104 cm                 |
| <b>GROUND CLEARANCE</b> | 2.5 in / 6.4 cm                |

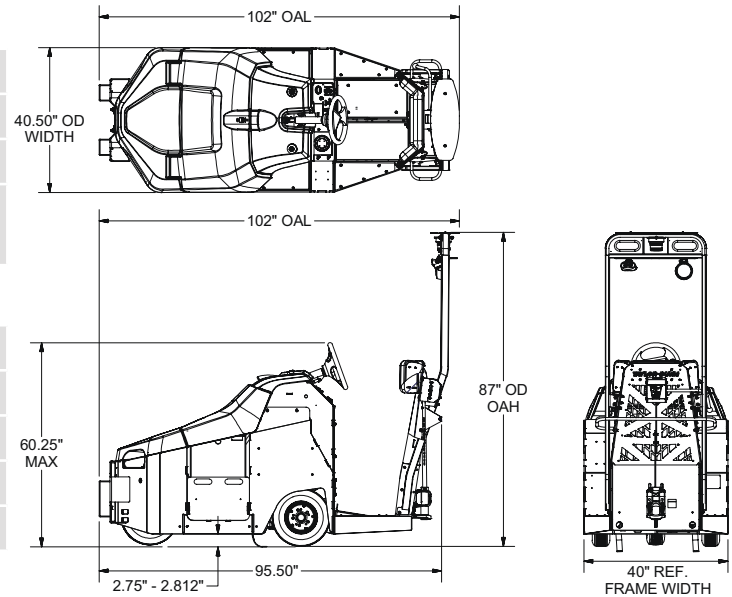
**POWER SUPPLY / DRIVE TRAIN**

|                            |                                                                                 |
|----------------------------|---------------------------------------------------------------------------------|
| <b>SYSTEM VOLTAGE</b>      | 36 Volt                                                                         |
| <b>MOTOR</b>               | 10 Hp AC                                                                        |
| <b>DRIVE AXLE</b>          | GT automotive differential                                                      |
| <b>BATTERY</b>             | Multiple options                                                                |
| <b>BATTERY COMPARTMENT</b> | 37.75" L x 15.25" W x 23.625" H / 95cm L x 38cm W x 60cm H                      |
| <b>CHARGER</b>             | AC Controller, 36V, DC/DC Converter, on with key switch, with automatic e-brake |
| <b>CONTROLLER</b>          | AC speed controller, 480 amp                                                    |

**CHASSIS**

|                   |                                                                                        |
|-------------------|----------------------------------------------------------------------------------------|
| <b>FRAME</b>      | Fully welded, unitized, 3/8 inch steel                                                 |
| <b>STEERING</b>   | Power steering with adjustable wheel height                                            |
| <b>SUSPENSION</b> | Front dual coil suspension and rear coil suspension with shock absorbers               |
| <b>BRAKES</b>     | Rear wheel hydraulic disc brakes with regenerative braking and automatic parking brake |
| <b>TIRES</b>      | 4.00 x 8, soft solid, non-marking, traction tread                                      |

**GENERAL**

|                             |                                                                                                                                                                                                                         |
|-----------------------------|-------------------------------------------------------------------------------------------------------------------------------------------------------------------------------------------------------------------------|
| <b>MAXIMUM OCCUPANCY</b>    | 1 / 350 lb (159 kg)                                                                                                                                                                                                     |
| <b>UNIT WEIGHT</b>          | 2,200 lb / 998 kg (LESS BATTERY)                                                                                                                                                                                        |
| <b>INSTRUMENTATION</b>      | Smart View Display: (battery status indicator, hour meter, fault code display), key switch, light switch, reverse beeper and light switch, emergency power stop switch, DC / DC converter, dual USB port, electric horn |
| <b>OPTIONAL ACCESSORIES</b> | Dual LED headlights, running lights, brake lights, pedestrian warning light, light bar, front bumper, seatback wings, soft solid tires, and electronic power steering                                                   |
| <b>HITCH</b>                | *Spring loaded E-type with hand release lever (*Optional)                                                                                                                                                               |
| <b>STORAGE COMPARTMENTS</b> | Cup holder, dual document slots and tablet compartment                                                                                                                                                                  |
| <b>CONFORMANCE</b>          | Type E OSHA 1910.178, ANSI B56.9                                                                                                                                                                                        |
| <b>WARRANTY</b>             | 2 YEAR / 2,000 HR                                                                                                                                                                                                       |

**FOR MORE INFORMATION VISIT**  
**POLARIS.COM/MATERIALHANDLING**

Final vehicle configurations to be determined. Specs are subject to change.