

# SERVICE DEPARTMENT

## A SERVICE DEPARTMENT IN YOUR OWN IMAGE

---

Rousseau's workcenters for technicians are the most complete and versatile solutions on the market. Our specialists will help you find a custom configuration that meets your unique requirements and reflects the professional image of your company.



Mercedes-Benz Winnipeg (MB)

## A COMPLETE SOLUTION

---

We have the perfect solution, whether you are looking for basic workstations with a little or a lot of storage, or a more comprehensive workcenter with integrated lift motor control, computer systems, reels and much more.

We have a wide range of additional options, including MultiTek Carts for technicians, waste containers, utility panels and power feed panels, so you can add everything you need to your workstation.

## A PERSONALIZED SOLUTION

---

Rousseau designs and manufactures its workstations with a height of 36" to ensure they are as ergonomic as possible. This is the perfect height to work standing up in a service department for the vast majority of people. However, if your team members need extra height, 40"H work surfaces are also available.

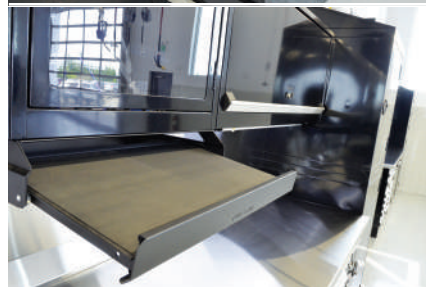
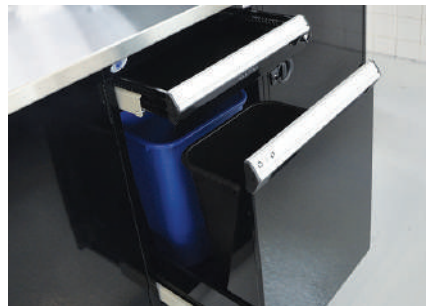

## TRY OUT OUR BAY DESIGN TOOL!

Do you have an idea what kind of workcenter you need? If you do and would like a quick preview of what your ideal workcenter would look like, be sure to try out our Bay Design tool on MyModel-r.com.

In just a few easy steps, you can configure your very own workcenter. If you can't find exactly what you're looking for with our Bay Design tool, don't worry. The tool only shows the most popular dimensions, options and accessories, but others are available. For a personalized solution, our team of specialists will suggest options and help you find a configuration that meets your requirements.

The Bay Design tool offers a way for you to create and preview a custom layout in just a few easy steps. When you're happy with your design, you can save it or request a quote with your desired specifications.

Give it a try!



SCAN THE QR CODE TO SET UP YOUR WORKSTATION TO SUIT YOUR NEEDS.

## OPTIMIZING WORKSPACES FOR ELECTRIC VEHICLE MAINTENANCE

With the growing popularity of electric vehicles (EVs), adapting workspaces for their specific maintenance is crucial. While the layout of workbenches and toolboxes is similar for servicing any vehicle, certain elements can make a difference when customizing a workstation for EVs.

An ideal approach is to maintain a versatile workspace that provides a tailored work surface as needed and has dedicated locations for EV-specific tools.

Essential tools to consider for effective EV maintenance include insulated tools, personal protective equipment, safety signage, a high-voltage rescue hook, a shutdown key, fire blankets, and a car charger.

Effective identification methods, such as color-coded drawers, and doors containing tools specific to EVs can help provide an efficient and secure workspace.



GT-C1044X

## NEED INSPIRATION?

Take a look at our Portfolio on [www.rousseau.com/industries/automotive](http://www.rousseau.com/industries/automotive)

### ROUSSEAU EXPERTISE

#### DESIGNED, DEVELOPED AND MANUFACTURED IN NORTH AMERICA

We invest heavily in product development, modernization of our facilities, new technologies and our employees to offer premium-quality products, from design to manufacturing to end product. Our goal is to understand your requirements so we can create tailored solutions that meet your expectations and needs in terms

of your environment (new construction or existing construction) and priorities.



SERVICE DEPARTMENT		2-3
Ergonomic Workstation		4-5
Create Your Own Workcenter		6-17
Double Workcenters		18-25
Single Workcenters		26-31
Corner Workstations		32-37
TekZone Hutch		38-41
Toolboxes		42-52
R2V Vertical Storage		53-58
Cabinet for two users		59-60



SCAN THE QR CODE TO DISCOVER THE PROJECTS COMPLETED BY ROUSSEAU

# ERGONOMIC WORKSTATION

## FACTORS TO CONSIDER

The first step in creating an optimal storage solution is to list all the tools and items to be stored. You can't store all these items in the same cabinet, drawer or shelf, so you need to categorize them.

To do this, there are four factors and four reach zones to consider when organizing your storage solution.



### 1- FREQUENCY OF USE

It's important to know how often your tools are used. This generally determines the location of your equipment. We can divide frequency of use into four categories: frequent, average, occasional and specific. We recommend storing frequently used items in easy-to-reach zones (green and yellow).

### 2- IMPORTANCE OF QUICK IDENTIFICATION

We recommend using the 5S methodology for organizing your tools. Items that need to be found or used quickly should be placed in easy-to-reach zones.

### 3- SIZE AND WEIGHT

The weight of items handled is an other important factor to take into account. By considering this in conjunction with frequency of use, it's easier to determine the best storage location. A heavy item used frequently should always be stored where the risk of injury is lowest. This will rule out zones that are too high or too low. However, a less ergonomic location is suitable if the heavy item is not used frequently. We should only be retrieving light items in high-reach zones.

### 4- PURPOSE AND CATEGORY

In some situations, you might want to group several items together according to type or how they are used. For example, you may want to group all screwdrivers together in the same drawer, even if you don't use all sizes with the same frequency.

## STORING AND ORGANIZING ITEMS

Place your items in the storage solution according to these four factors within the four zones shown here. In this illustration, we have used a person of average height. We recommend using a 50th percentile adult when more than one person works in the same space. See technical guide R69 for ergonomic designs for taller or smaller people.

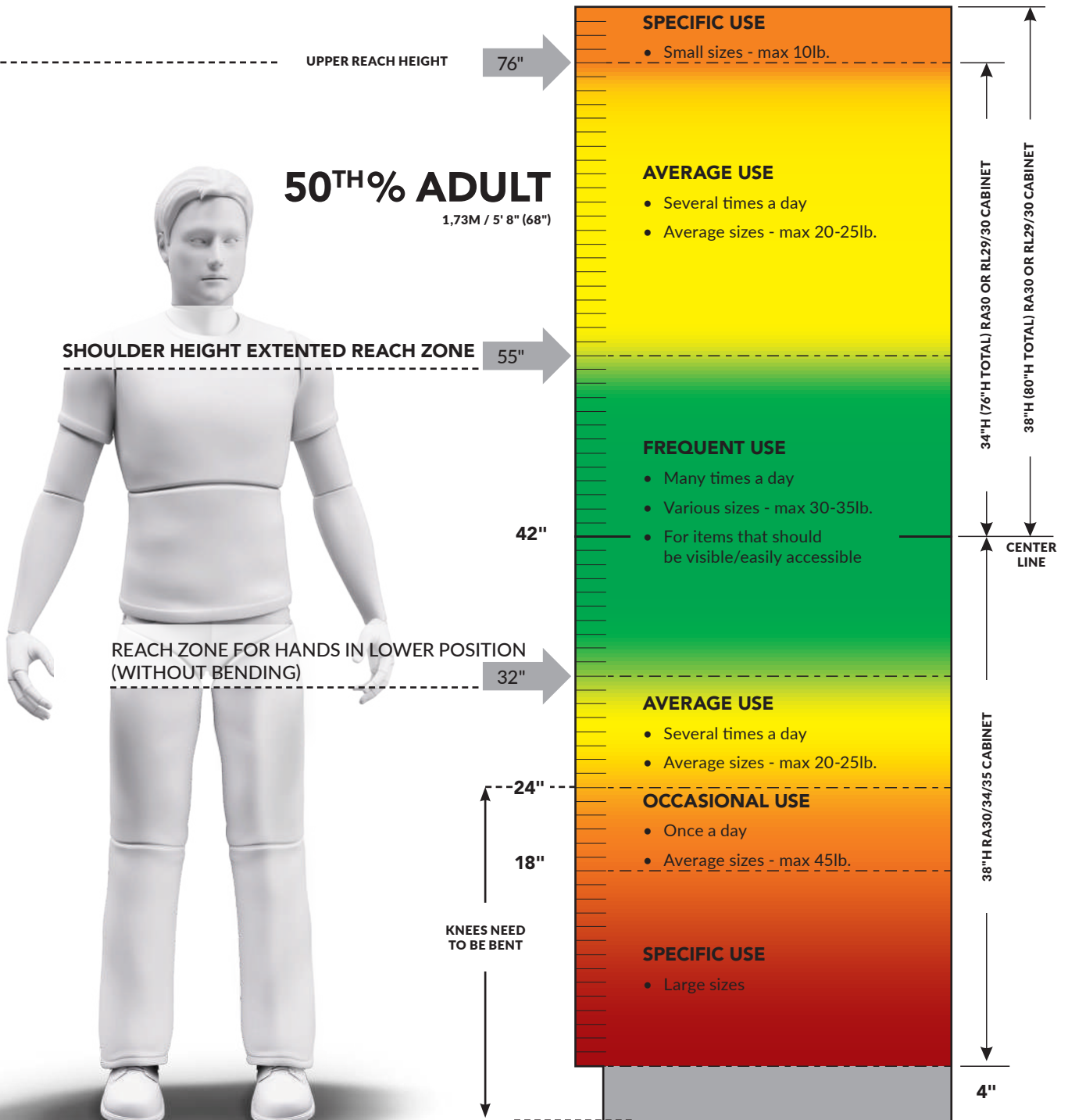

# CREATE YOUR OWN WORKCENTER

## 5 EASY STEPS

Our specialists will work with you to evaluate the best configurations for your situation. They will take into consideration many different factors by asking various questions:

- What is the total amount of space available?
- Is computer access required?
- How much space is needed for tools?
- Where do the reels come from (air, electricity, oil, etc.)?

- How much space is needed for storage of bulky items?
- What type of lift do you use (integrated or posts, what brand)?
- Do you need task lighting?
- Etc.

In just five steps, we can help you create your own layout quickly and easily. The following pages take you through these steps.

## SEE THE DIFFERENCE...



# HOW TO CREATE YOUR OWN WORKCENTER

Following the steps below, you can create a custom layout by choosing models from those suggested on [pages 20-33](#) (144"W, 120"W, 96"W, 84"W, 72"W, 60"W and 48"W models).

To order, complete the product numbers as shown in the steps below.

## 1 TYPE OF WORK SURFACE

Widths: **48", 60", 72", 84", 96", 120"** and **144"** (2 × 72")

Type of work surface: 16ga painted or stainless steel

Rubber mat available: Mats are 26" deep to accommodate tech uprights, cover panels and power feed panels.

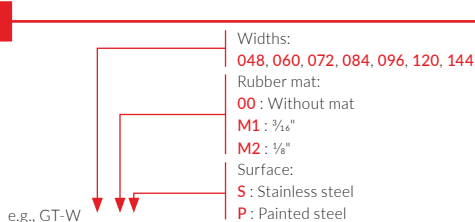

## 2 UNDER THE WORK SURFACE

The suggested models are some of the most popular. Simply add **S** to the end of the model number for a stainless steel base, or **P** for a painted steel base.

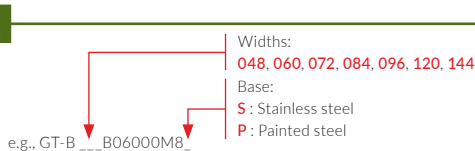

## 3 ABOVE THE WORK SURFACE

Widths: **48", 60", 72", 84", 96", 120"** and **144"** (2 × 72")

Includes: storage cabinet, computer cabinet, power feed panel, cover panel, tech uprights and panel support

Panel: painted or stainless steel

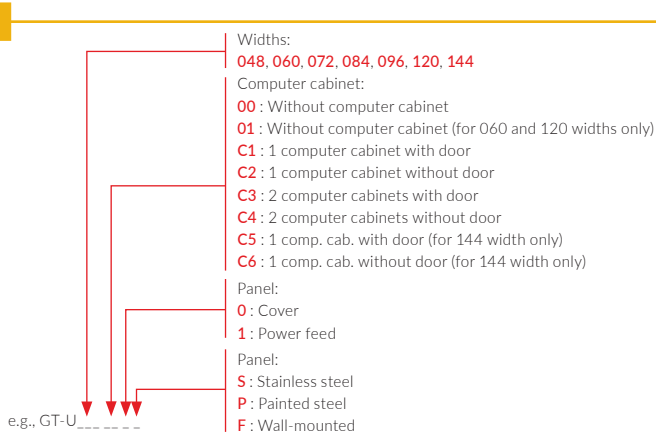

## 4 CENTER

### WITH CABINETS (ABOVE THE WORK SURFACE)

Widths: **48", 60", 72", 84", 96", 120"** and **144"** (2 × 72")

Includes: finishing panel, utility panel and plastic bin panel

Finishing and utility panel: painted or stainless steel

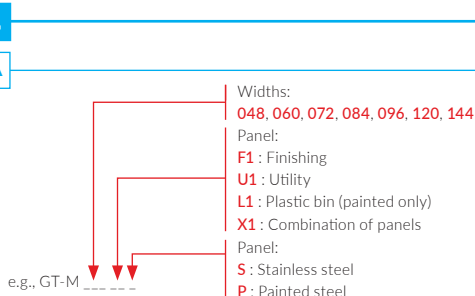

### WITHOUT CABINETS (ABOVE THE WORK SURFACE)

Widths: **48", 60", 72", 84", 96", 120"** and **144"** (2 × 72")

Includes: finishing panel, tech uprights, panel support, cover panel and power feed panel

Panel: painted or stainless steel

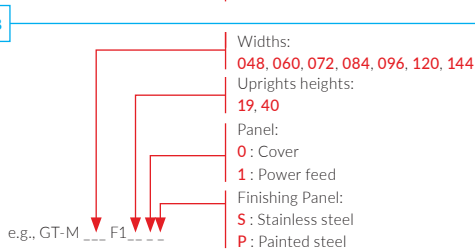

### WITHOUT TECH UPRIGHTS (ABOVE THE WORK SURFACE)

Widths: **48", 60", 72", 84", 96", 120"** and **144"** (2 × 72")

Includes: finishing panel for computer arm, cover panel and power feed panel without tech uprights, monitor mount

Finishing panel: painted steel or stainless steel

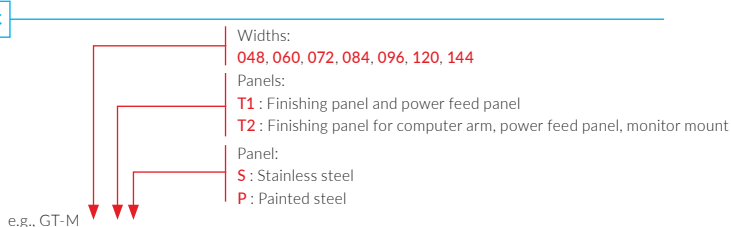

## 5 SIDES OF BAYS

See page 19

# 1 TYPE OF WORK SURFACE

NOTE: THE WIDTH OF THE WORK SURFACE DETERMINES THE WIDTH FOR STEPS **2**, **3** AND **4**.

## STAINLESS STEEL TOP



- Acts as a work surface and protects the top of the cabinet from impacts
- Particle board top with stainless steel cover (#4 brushed finish)
- Excellent chemical resistance
- Excellent corrosion resistance
- Welded corners for an attractive appearance
- Available in 12ga or 16ga steel (12ga steel top provides better impact resistance)
- 12ga top thickness: 1<sup>3</sup>/<sub>16</sub>"
- 16ga top thickness: 1<sup>3</sup>/<sub>4</sub>"

PRODUCT NO.	W × D
RC35-4830-__	48" × 30"
RC35-6030-__	60" × 30"
RC35-7230-__	72" × 30"
RC35-8430-__	84" × 30"
RC35-9630-__	96" × 30"
RC35-12030-__	120" × 30"

NOTES: Add **12** to the product number for a 12ga steel top.  
For a 144"W workstation, order two 72"W tops.

## MARINE EDGE STAINLESS STEEL TOP



- The edge stops hardware and liquids from falling off
- Acts as a work surface and protects the top of the cabinet from impacts
- Particle board top with stainless steel cover (#4 brushed finish)
- Excellent chemical resistance
- Excellent corrosion resistance
- Welded corners for an attractive appearance
- Available in 12ga or 16ga steel (12ga steel top provides better impact resistance)
- 12ga top thickness: 1<sup>3</sup>/<sub>16</sub>" and 2" edge
- 16ga top thickness: 1<sup>3</sup>/<sub>4</sub>" and 1<sup>5</sup>/<sub>16</sub>" edge

PRODUCT NO.	W × D
RC35-4830-__M	48" × 30"
RC35-6030-__M	60" × 30"
RC35-7230-__M	72" × 30"
RC35-8430-__M	84" × 30"
RC35-9630-__M	96" × 30"
RC35-12030-__M	120" × 30"

NOTES: Add **12** to the product number for a 12ga steel top, or **16** for a 16ga steel top.  
For a 144"W workstation, order two 72"W tops.

## PAINTED STEEL TOP



- Acts as a work surface and protects the top of the cabinet from impacts
- Particle board top with painted steel cover
- Welded corners for an attractive appearance
- Thickness: 1<sup>3</sup>/<sub>4</sub>"

PRODUCT NO.	W × D
RC37-4830	48" × 30"
RC37-6030	60" × 30"
RC37-7230	72" × 30"
RC37-8430	84" × 30"
RC37-9630	96" × 30"
RC37-12030	120" × 30"

NOTE: For a 144"W workstation, order two 72"W tops.

## NEOPRENE RUBBER MAT



- Neoprene mat for protecting the work surface
- Thickness: 1/8"
- Order a 26"D mat for use with tech uprights, or 30"D for use without tech uprights.

WIDTH	DEPTH	
	26"	30"
48"	RG45-4826	RG45-4830
60"	RG45-6026	RG45-6030
72"	RG45-7226	RG45-7230
84"	RG45-8426	RG45-8430
96"	RG45-9626	RG45-9630
120"	RG45-12026	RG45-12030
144"	RG45-14426	RG45-14430

NOTE: Not compatible with the marine edge stainless steel top.

## NITRILE RUBBER MAT



- Nitrile mat with excellent hydrocarbon and shock resistance
- Thickness: 3/16"
- Order a 26"D mat for use with tech uprights, or 30"D for use without tech uprights.

WIDTH	DEPTH	
	26"	30"
48"	RG48-4826	RG48-4830
60"	RG48-6026	RG48-6030
72"	RG48-7226	RG48-7230
84"	RG48-8426	RG48-8430
96"	RG48-9626	RG48-9630
120"	RG48-12026	RG48-12030
144"	RG48-14426	RG48-14430

NOTE: Not compatible with the marine edge stainless steel top.

## 2 UNDER THE WORK SURFACE

### SLIDING LIFT MOTOR UNIT FOR ROTARY SHOCKWAVE™



- Quick and easy access to the lift control by sliding the unit out
- Easy access to the lift control on both sides
- Unit includes housing and a removable front
- 4"H base: painted or stainless steel
- Compatible with 120V only
- Optional leveling glides: RA75-01

PRODUCT NO.	TYPE OF BASE	W×D×H
RC05-18273401	Painted steel	18"×27"×34"
RC06-18273401	Stainless steel	18"×27"×34"
RC05-18273801	Painted steel	18"×27"×38"
RC06-18273801	Stainless steel	18"×27"×38"

### STRUCTURAL CLOSED LEG



- Available for ends or middle of workstation
- Provides adequate support for integrating non-structural elements under the work surface (for over 18"W). Leg is 3" wide
- The middle leg can be used to create workstations wider than 72" without needing another structural element for support
- Two options available: Two 15A power outlets, or one 15A power outlet with two USB ports
- Use a stringer (RC77) for applications that only use legs
- Two base types available (4"H): recessed or full depth
- The base is available in painted or stainless steel
- Includes leveling glides
- An inside finishing panel (RC74) is also available for a more finished look

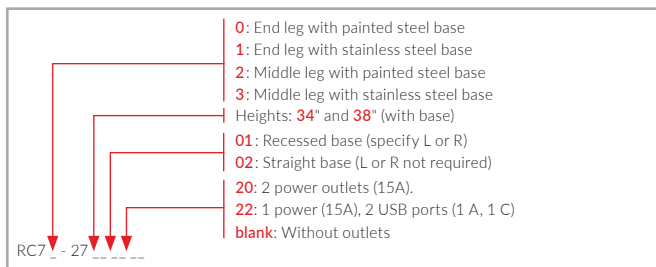

### CROSSMEMBER



- Supports closed legs when used at the end of the workstation
- Connects the leg to another structural element on the workstation to provide extra rigidity at the bottom
- Stainless steel

PRODUCT NO.
RC78-__

NOTE: Complete the product number with the width required: 18", 21", 24", 27", 30", 36", 42" or 48".

### SLIDING LIFT MOTOR UNIT



- Quick and easy access to the lift control by sliding the unit out
- Easy access to the lift control on both sides
- Available for Rotary Mechanical, Rotary inground SmartLift®, Challenger with BMC and Challenger EnviroLift®
- Includes housing
- 4"H base: painted or stainless steel
- Compatible with 220 V only
- Optional leveling glides: RA75-01

PRODUCT NO.	TYPE OF LIFT
RC__-1227__01	Challenger with BMC (controls on the workstation)
RC__-1227__05	Rotary inground SmartLift® (2007 version to present)
RC__-1227__07	Rotary Mechanical (conventional controls, September 2010 to present)
RC__-1227__08	Challenger EnviroLift® without BMC before 2015
RC__-1227__09	Challenger with BMC (controls integrated into sliding lift motor unit)
RC__-1227__10	Challenger EnviroLift® without BMC after 2015

NOTES: Add 20 to the RC\_\_ product number for a painted steel base, or 21 for a stainless steel base.  
 Add 34 to the product number for a 36"H workstation, or 38 for a 40"H workstation.

### HIDEAWAY DOOR



- Designed to conceal waste containers (RK06), MultiTek Carts and L Mobile Cabinets under the work surface
- Includes a handle to easily open the door
- Available with or without a lock

PRODUCT NO.	W×H	NOMINAL HEIGHT
RB52-1834__	18"×34"	30"
RB52-2134__	21"×34"	30"
RB52-2434__	24"×34"	30"
RB52-2734__	27"×34"	30"
RB52-1838__	18"×38"	34"
RB52-2138__	21"×38"	34"
RB52-2438__	24"×38"	34"
RB52-2738__	27"×38"	34"

NOTES: Add L3 to the end of the product number to order a hideaway door with L3 key lock.  
 Add L to the end of the product number to have the hinges on the left or R for the hinges on the right.  
 Order a 21"W or 24"W hideaway door to fit an L Mobile Cabinet.

### DOOR EXTENSION



- Compatible with RB52 Hideaway Door
- Provides an immaculate finish
- Available in painted steel or stainless steel
- Compatible with a 23"W MultiTek Cart

PRODUCT NO.	W×H
RB__-180401	18"×4"
RB__-210401	21"×4"
RB__-240401	24"×4"
RB__-270401	27"×4"

NOTE: Add 59 to the product number for a painted steel extension or 60 for a stainless steel extension.

## 2 UNDER THE WORK SURFACE

### WASTE & RECYCLING DOOR



- Designed to seamlessly integrate waste and recycling containers (RK08/RK09) under the work surface without affecting the usable surface area
- Includes a stainless steel flipper door for discarding waste without needing to open the panel
- A panel support (RB57) must be ordered for units installed at the end of a bay
- A base (RA59/RA60) must be ordered for seamless integration under the work surface

PRODUCT NO.	HINGE	HEIGHT
RB53-2434L	Left	34"
RB53-2434R	Right	34"
RB53-2438L	Left	38"
RB53-2438R	Right	38"

### WASTE & RECYCLING DRAWER



- Used for sorting waste and items for recycling
- Logos on the side to facilitate sorting
- Drawer heights available: 17", 26" and 30"
- Holds two containers (one black and one blue) with a divider that secures the containers and allows items to be stored behind

PRODUCT NO.	W × D × H	CONTAINER SIZE
R51CG-X1701	24" × 27" × 17"	Small (7 gallons/26.5 liters)
R51DG-X1701	30" × 27" × 17"	Small (7 gallons/26.5 liters)
R51CG-X2601	24" × 27" × 26"	Large (10 gallons/39 liters)
R51DG-X2601	30" × 27" × 26"	Large (10 gallons/39 liters)
R51CG-X3001	24" × 27" × 30"	Large (10 gallons/39 liters)
R51DG-X3001	30" × 27" × 30"	Large (10 gallons/39 liters)

### WASTE & RECYCLING CABINET



- Can be used as a standalone unit, as part of a cabinet configuration or integrated underneath the work surface
- Used for sorting waste and items for recycling
- The 30"H unit includes a 26"H drawer with labeled handle to facilitate sorting; the 34"H unit also includes a 4"H drawer
- Includes two 15 ¼"W × 11"D × 20"H containers: a black one for waste (RK09-02) and a blue one for recycling (RK09-01)
- The drawer includes a divider which secures the containers and also allows items to be stored behind
- Optional leveling glides: RA74-01

PRODUCT NO.	W × D × H	WORKSTATION HEIGHT
GT-5ACG30050_	24" × 27" × 34"	36"
GT-5ACG34050_	24" × 27" × 38"	40"
GT-5ADG30050_	30" × 27" × 34"	36"
GT-5ADG34050_	30" × 27" × 38"	40"

NOTE: Add **S** to the end of the product number for a stainless steel base or **P** for a painted steel base.

### WASTE & RECYCLING DOORS



- Hide RK10 Waste & Recycling Containers under the work surface
- The doors are not full height so users can dispose of waste without opening the door
- Include hinges for opening door when emptying containers
- Include magnets to keep the door closed
- Include self-adhesive labels attached to the doors to identify the waste and recycling sides

PRODUCT NO.		WIDTH
RB58-24_-01L	Recycling	24"
RB58-24_-02R	Waste	24"
RB58-30_-01L	Recycling	30"
RB58-30_-02R	Waste	30"

NOTES: 17"H panels are recommended for 36"H workstations; 21"H panels are recommended for 40"H workstations. Complete the product number with the height required: **17"** or **21"**.

By default, the recycling door is on the left and the waste door is on the right.

### WASTE CONTAINER



- Capacity: 28 gallons (the square bin has 14% greater capacity than the round bin)
- Rounded corners for easier cleaning
- Dimensions: 21 ½"W (25"W with handles) × 21 ½"D × 22 ½"H
- Optional door is available for seamless integration under the work surface (RB52)
- Mobile pedestal also available (RK07)

PRODUCT NO.	INCLUDES
RK06-01	Waste container
RK07-01	Mobile pedestal

### WASTE AND RECYCLING CONTAINERS



- Used for sorting waste and items for recycling
- 3 sizes:
  - **Small** (14 ¾"W × 10 ¼"D × 15"H) for a 17"H Waste & Recycling Drawer (R51CG-X1701 and R51DG-X1701)
  - **Large** (15 ¼"W × 11"D × 20"H) for use with an RB53 Waste & Recycling Drawer or a 26"H Waste & Recycling Drawer (R51CG-X2601) and R51DG-X2601)
  - **Extra large** (18 ¾"W × 23 ½"D × 16 ½"H) recommended for RB58 Waste & Recycling Doors

PRODUCT NO.	SIZE	COLOR
RK08-01	Small (7 gallons/26.5 liters)	Blue
RK08-02	Small (7 gallons/26.5 liters)	Black
RK09-01	Large (10 gallons/39 liters)	Blue
RK09-02	Large (10 gallons/39 liters)	Black
RK10-01	Extra large (18 gallons/68 liters)	Blue
RK10-02	Extra large (18 gallons/68 liters)	Gray

## HEIGHT-ADJUSTABLE ARTICULATING ARM

All models featured here have the following characteristics:

- Installs on the work surface with an RC68 or RC69 cover panel for electronics mounts, does not install directly on the housing
- Compatible with the following work surfaces: RC35, RC37 and WS14
- Includes an 18"H pole
- The work surface must extend beyond the rear by 1½"
- Optimum ergonomics

## WITHOUT UPRIGHTS

EASY CABLE MANAGEMENT



## MONITOR ARM



- Compatible with most monitors (max. 21") on the market
- Complies with VESA 75 and 100 monitor mounting standards
- Includes a height adjustable articulating arm(s) with two joints
- The articulating arm with two joints provides extra adjustment options
- Screen can be rotated and tilted
- Single and dual arm versions are available
- Arm includes a channel for cable management
- Height can be adjusted tool free
- Capacity: 20 lb
- Color: Black

PRODUCT NO.	FOR
RC59-03	Single Monitor
RC59-04	Two Monitors

## LAPTOP ARM



- Holds a laptop, electronic device or any other object
- Tray's usable area: 19"W × 14"D
- Includes a height adjustable articulating arm with two joints
- The articulating arm with two joints provides extra adjustment options
- Includes ½"H edges on the sides and back
- Tray can be rotated and tilted
- Arm includes a channel for cable management
- Height can be adjusted tool free
- Capacity: 20 lb
- Color: Black

PRODUCT NO.
RC59-42

## MONITOR MOUNT AND KEYBOARD AND MOUSE ARM



- Holds a computer monitor, keyboard and mouse
- Compatible with most monitors (max. 21") on the market
- Complies with VESA 75 and 100 monitor mounting standards
- Keyboard tray's usable area: 23½"W × 8½"D
- Includes a height adjustable articulating arm with one joint
- Screen and tray can be rotated and tilted
- Arm includes a channel for cable management
- Height can be adjusted tool free
- Capacity: 14 lb
- Color: Black

PRODUCT NO.
RC59-21

## TABLET ARM



- Compatible with most tablets on the market
- The clamps and mount have a non-slip surface to keep the tablet stable
- Compatible tablet sizes:
  - Small: 7¾"W to 10"W
  - Large: 9¾"W to 12¼"W
- Includes a height adjustable articulating arm with or two joints
- The articulating arm with two joints provides extra adjustment options
- Height can be adjusted tool free
- Tablet can be rotated and tilted
- Arm includes a channel for cable management
- Capacity: 14 lb
- Color: Black

PRODUCT NO.	FOR
RC59-62-01	Small tablet
RC59-62-02	Large Tablet

# 3 ABOVE THE WORK SURFACE

## POWER FEED PANEL WITHOUT UPRIGHTS



- Includes a power bar with three 15A outlets for a 15A circuit
- Additional versions available: with a knockout for a pneumatic connection and a perforation (with a cover plate) for a telephone / Ethernet jack; or with two USB ports; or with knockout, perforation and two USB ports
- Installs on RC35 and RC37 tops
- Available in painted steel or stainless steel

4: Without uprights, painted steel  
 5: Without uprights, stainless steel  
 Widths:  
 30", 36", 42", 48", 54", 60" and 72"  
 10: 3 power outlets (15A)  
 11: 3 power outlets (15A), perforations  
 12: 3 power outlets (15A), 2 USB ports (1 A, 1 C)  
 13: 3 power outlets (15A), 2 USB ports (1 A, 1 C), knockout and perforation  
 01: Without back panel  
 02: With back panel (only available for applications without uprights)

RC6 \_ \_ \_ \_

e.g., RC64-361201 for a 36"W painted steel power feed panel with power outlet strip with 3 power outlets (15A), 2 USB ports, and without a back panel.



GC-C11675

## COVER PANEL FOR COMPUTER MOUNTS



- Provides a more aesthetic finish when installing computer mounts (RC59-03/RC59-04/RC59-21/RC59-42/RC59-62-01/02)
- Can be combined with a power feed panel (RC64/RC65) or cover panel (RC66/RC67) if required
- Available in painted steel or stainless steel
- Width: 24"

8: Painted steel  
 9: Stainless steel  
 01: Without back panel  
 02: With back panel

RC6 \_-24 \_ \_

## COVER PANEL WITHOUT UPRIGHTS



- Can be combined with a power feed panel when necessary, or used on its own for a perfect finish
- Available in stainless or painted steel

6: Without uprights, painted steel  
 7: Without uprights, stainless steel  
 Widths:  
 24", 30", 36", 42", 48", 54", 60" and 72"  
 01: Without back panel  
 02: With back panel (available for applications without uprights only)

RC6 \_ \_ \_ \_

e.g., RC66-3001 for a painted steel cover panel, 30" wide, without back panel.

## TECH UPRIGHTS



- For installation of a storage cabinet (RD02), computer cabinet (R5MCA), panel support (RC47), power feed panels (RC60/RC61) and cover panels (RC62/RC63)
- Allows height of cabinets to be adjusted in 4" increments
- Anchors securely to the work surface

PRODUCT NO.	HEIGHT
RD44-19	19"
RD44-40	40"

## PANEL SUPPORT



- Supports finishing panels (RC41/RC42), plastic bin panels (RC45), utility panels (RC93/RC94) and finishing panels for computer arm (RC81/RC82)
- Enables a combination of different panel types to be installed

PRODUCT NO.	WIDTH
RC47-24 _ _	24"
RC47-30 _ _	30"
RC47-36 _ _	36"
RC47-42 _ _	42"
RC47-48 _ _	48"
RC47-60 _ _	60"

NOTES: For 19" RD44 uprights, add 03 to the number.

For 40" RD44 uprights, add 01 to the number for the lower section and 02 for the upper section.

## SLOPED TOP FOR STORAGE CABINET AND COMPUTER CABINET



- Keeps the workspace clean and safe while reducing clutter
- Fits perfectly into the "5S" storage method
- 35° sloped top for computer cabinet and storage cabinet
- The top for computer cabinets includes a fan
- Height: 8"

PRODUCT NO.	FOR	W × D
RD42-241408	Storage cabinet	24" × 14"
RD42-301408	Storage cabinet	30" × 14"
RD42-361408	Storage cabinet	36" × 14"
RD42-421408	Storage cabinet	42" × 14"
RD42-481408	Storage cabinet	48" × 14"
RD42-601408	Storage cabinet	60" × 14"
RD43-241408	Computer cabinet	24" × 14"

## FLIPPER DOOR STORAGE CABINET



- Can be wall mounted or installed on RD44 tech uprights
- The back is removable when wall mounted allowing easy access to electrical components (power outlets)
- The flipper door has a large handle for a comfortable grip (RD20)
- Optional lamp produces optimized lighting (RD45)

PRODUCT NO.	W × D × H
R5MCB-2111	24" × 14" × 21"
R5MDB-2111	30" × 14" × 21"
R5MEB-2111	36" × 14" × 21"
R5MHB-2111	42" × 14" × 21"
R5MGB-2111	48" × 14" × 21"
R5MKB-2111	60" × 14" × 21"

NOTE: Flipper door storage cabinets include an L3 key lock. For an L50 digital lock or an L100 smart lock, please contact Customer Service.

## SLIDING DOOR STORAGE CABINET



- Can be wall mounted or installed on RD44 tech uprights
- The back is removable when wall mounted allowing easy access to electrical components (power outlets)
- Integrated door provides maximum clearance for handling items stored in the cabinet
- Polycarbonate door provides excellent impact resistance

PRODUCT NO.	W × D × H
R5MEB-21__	36" × 14" × 21"
R5MHB-21__	42" × 14" × 21"
R5MGB-21__	48" × 14" × 21"
R5MKB-21__	60" × 14" × 21"

NOTE: Add **07** to the product number for a solid integrated door or **08** for a polycarbonate integrated door.

## COMPUTER CABINET



- Includes a monitor mount to create room for a CPU and monitor
- Available with fan (for standalone use) or without fan (for use with sloped top)
- Includes a power outlet strip
- The keyboard tray (optional) can be tucked away under the cabinet when not in use
- Width: 24"

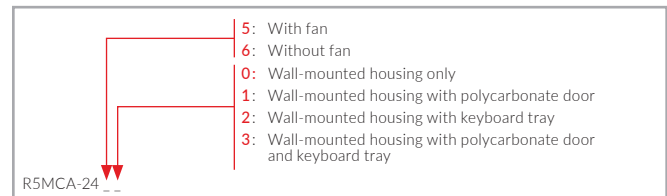

## LAPTOP, KEYBOARD & MOUSE TRAY



- Allows a laptop or keyboard and mouse to be used under a cabinet. Maximum laptop screen size: 15"
- Tucks away under the cabinet when not in use
- Tilts 17° when pulled out
- Includes a neoprene mat for better grip underneath the laptop or keyboard and mouse
- Opens easily and smoothly

PRODUCT NO.	FOR
RD47-2414	

## STORAGE UNIT



- Installs underneath a storage cabinet with or without an RD47 Laptop, Keyboard & Mouse Tray
- Can be installed underneath a computer cabinet with or without an RD47 Laptop, Keyboard & Mouse Tray
- Provides extra storage space
- Allows Laptop, Keyboard & Mouse Tray to be lowered by 4"
- Width: 24"

PRODUCT NO.	FOR
RD48-24140401	Computer cabinet and storage cabinet (24"W)
RD48-24140403	Storage cabinet over 24"W

# 3 ABOVE THE WORK SURFACE

## LED LIGHT



- Brighter and more energy efficient than a fluorescent tube
- Brightens shaded areas under cabinets
- Can be installed under RD00/ RD02 cabinets
- Color temperature: 5000-6000K (day white)
- Includes a galvanized steel adapter
- Includes a 10' power cord
- The recommended operating temperature for our LED lights is between 5 and 40 °C (41 to 104 °F)
- An optional motion sensor can be added

PRODUCT NO.	STORAGE CABINET WIDTH	LIGHT WIDTH
RD45-1814__	24"	15"
RD45-2414__	30", 36"	21"
RD45-3614__	42", 48", 24"+ 24"	33"
RD45-4814__	60", 30" + 30"	45"
RD45-6014__	36" + 36"	57"

NOTES: To order an LED light with motion sensor, add **MS** to the product number.  
Not compatible with computer cabinets.

## CONNECTING CABLE



- Up to 7 lights can be connected in series
- Each light is independent and controlled by its own switch

PRODUCT NO.	CABLE LENGTH
70001108	8"
70001112	12"
70001124	24"

## PLASTIC WRAP ROLL HOLDER



- Ideal for rolls of protective plastic for car seats
- Installs under an RD02 storage cabinet
- Total load capacity: 50lb.

PRODUCT NO.	WIDTH
RD46-4814	48"
RD46-6014	60"

NOTE: Not compatible with LED light.

## POWER FEED PANEL WITH UPRIGHTS



- Includes a power bar with three 15A outlets for a 15A circuit
- Additional versions available: with a knockout for a pneumatic connection and a perforation (with a cover plate) for a telephone/Ethernet jack; or with two USB ports; or with knockout, perforation and two USB ports
- Installs on RC35 and RC37 tops
- Designed for use with tech uprights (RD44)
- Available in painted steel or stainless steel

	0: With uprights, painted steel
	1: With uprights, stainless steel
Widths:	
30", 36", 42", 48" and 60"	
10: 3 power outlets (15A)	
11: 3 power outlets (15A), perforations	
12: 3 power outlets (15A), 2 USB ports (1 A, 1 C)	
13: 3 power outlets (15A), 2 USB ports (1 A, 1 C), knockout and perforation	

e.g., RC61-361201 for a 36"W stainless steel power feed panel with uprights, with a power outlet strip with 3 power outlets (15A) and 2 USB ports.



10: 3 power outlets (15A)



11: 3 power outlets (15A), a knockout for a pneumatic connection and a perforation (with cover plate) for installing a telephone or network jack

## COVER PANEL WITH UPRIGHTS



- Can be combined with a power feed panel or used on its own to cover the feet of tech uprights for an immaculate finish
- Designed for use with tech uprights (RD44);
- Available in painted steel or stainless steel

	2: With uprights, painted steel
	3: With uprights, stainless steel
Widths:	
24", 30", 36", 42", 48" and 60"	

e.g., RC62-3001 for a 30"W painted steel cover panel with uprights.



12: 3 power outlets (15A) and 2 USB ports



13: 3 power outlets (15A), 2 USB ports, a knockout for a pneumatic connection and a perforation (with cover plate) for installing a telephone or network jack

UTILITY PANEL

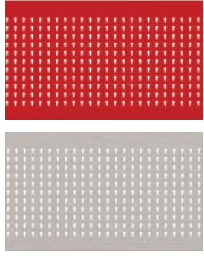

- Includes perforations spaced 1" apart c/c and is compatible with all WM9\_ hooks and holders (see page 119)

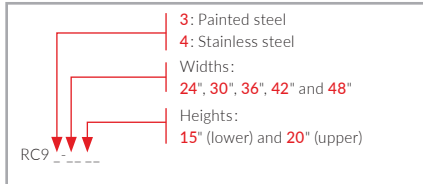

NOTE: Not compatible with the WM21 Tilttable Shelf for Utility Panel.

PLASTIC BIN PANEL



- Compatible with RG20 plastic bins (see page 121) and all brands of plastic bins with hanging lip on the market

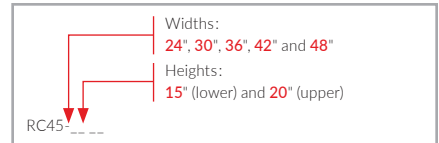

FINISHING PANEL

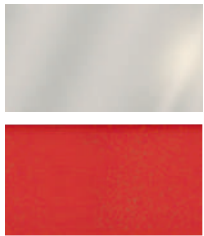

- Provides an immaculate finish
- Available in painted and stainless steel
- Can be used with or without a cabinet on top
- Two panels can be stacked (15"H + 20"H) to create a full height wall, which can hold accessories as needed
- Panels are compatible with the following accessories: multi-purpose holders (RC51), monitor mounts (RC52), keyboard & mouse tray (RC53), multi-purpose supports (RC54)

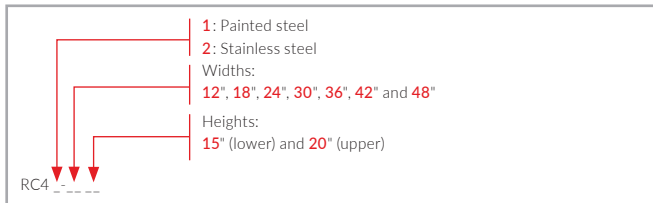

FINISHING PANEL FOR COMPUTER ARM



- Available in painted and stainless steel
- Can be used with or without a cabinet on top
- Two panels can be stacked (15" + 20")
- Panels are compatible with the following accessories: RC58-03/RC58-21/RC58-42/RC58-62
- Includes perforation for running cables through
- Width: 12"

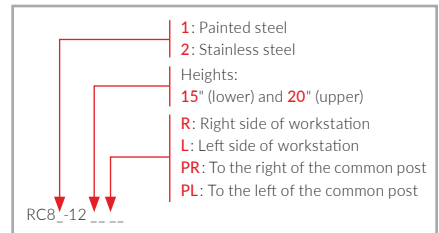

NOTE: Determine where the panel will be placed on the workstation and order the appropriate part (R, L, PR, PL). The panel cannot be installed anywhere other than the designated location.



## MULTI-PURPOSE HOLDER



- Holds up to 4 aerosol cans
- Also compatible with drinks cans
- Hooks securely onto RC41/RC42/RC93/RC94/RC45 panels
- Can be installed anywhere across the width of the bay

PRODUCT NO.	COMBINATION
RC51-120303	Panels only
RC51-120312	Panels and storage cabinets



## PHONE AND DOCUMENT HOLDER

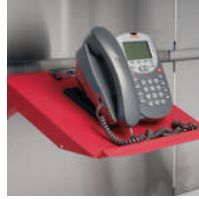

- Usable surface area: 14"W x 12"D
- Includes a clip to keep documents in place
- Hooks securely onto RC41/RC42/RC93/RC94/RC45 panels
- Can be installed anywhere across the width of the bay

PRODUCT NO.	COMBINATION
RC54-1412	Panels only
RC54-141202	Panels and storage cabinets



GT-C2047S

**HEIGHT-ADJUSTABLE ARTICULATING ARM**

All models featured here have the following characteristics:

- Installs on finishing panel for computer arm
- Easy cable management
- Optimum ergonomics

**EASY CABLE MANAGEMENT**

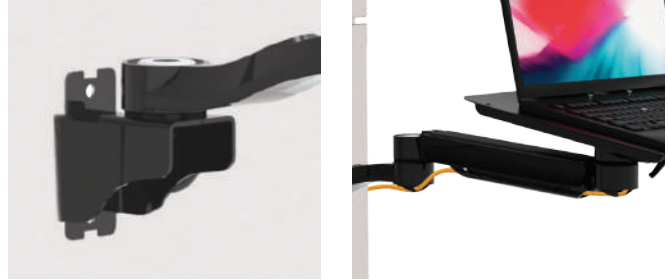

**MONITOR ARM**



- Compatible with most monitors (max. 21") on the market
- Complies with VESA 75 and 100 monitor mounting standards
- Includes an articulating arm with two joints
- The articulating arm with two joints provides extra adjustment options
- Monitor can be rotated and tilted
- Installs on a lower (15") finishing panel for computer arm (RC81/RC82)

**PRODUCT NO.**  
RC58-03

**LAPTOP ARM**



- Holds a laptop, electronic device or any other object
- Tray's usable area: 14"W x 12"D
- Includes an articulating arm with two joints
- The articulating arm with two joints provides extra adjustment options
- Tray can be rotated and tilted
- Installs on a lower (15") finishing panel for computer arm (RC81/RC82)

**PRODUCT NO.**  
RC58-42

**MONITOR MOUNT AND KEYBOARD & MOUSE ARM**



- Holds a computer monitor, keyboard and mouse
- Keyboard tray's usable area: 23 5/8"W x 8 1/2"D
- Includes an articulating arm with a single joint
- Compatible with most monitors (max. 21") on the market
- Complies with VESA 75 and 100 monitor mounting standards
- Monitor and tray can be rotated and tilted
- Installs on a lower (15) and upper (20) finishing panel for computer arm (RC81/RC82)

**PRODUCT NO.**  
RC58-21

**TABLET ARM**



- Compatible with most tablets on the market
- The clamps and mount have a non-slip surface to keep the tablet stable
- Includes an articulating arm with two joints
- The articulating arm with two joints provides extra adjustment options
- Tablet can be rotated and tilted
- Installs on a lower (15") finishing panel for computer arm (RC81/RC82)
- Compatible tablet sizes:
  - Small: 7 5/8"W to 10"W
  - Large: 9 7/8"W to 12 1/4"W

PRODUCT NO.	FOR
RC58-62-01	Small
RC58-62-02	Large



# 4 CENTER

## KEYBOARD & MOUSE TRAY



- Usable surface area: 24"W x 12"D for a keyboard and mouse
- Includes a series of bends at the front (3/4" surface) that act as a palm rest
- Hooks securely onto RC41/RC42/RC93/RC94/RC45 panels
- Can be installed anywhere across the width of the bay

PRODUCT NO.	COMBINATION
RC53-2412	Panels only
RC53-241202	Panels and storage cabinets

## LAPTOP TRAY



- Supports laptops of up to 14"W x 12"D
- Hooks securely onto RC41/RC42/RC93/RC94/RC45 panels
- Includes a series of bends at the front (3/4" surface) that act as a palm rest
- Can be installed anywhere across the width of the bay

PRODUCT NO.
RC54-1412

## MONITOR MOUNT



- Supports monitors and RC41/RC42/RC93/RC94/RC45 panels
- Complies with VESA 75 and 100 monitor mounting standards
- Includes a central cutout for cable management from the rear of the mount
- Two positions: vertical or angled 10° forward to reduce reflections

PRODUCT NO.
RC52-20



GT-C1034S



GT-C1069S



### 5A TOOLBOXES - PAGES 44-54

- Toolboxes can be ordered on their own or as components of a workcenter as featured on [pages 20-33](#)
- 10 drawer heights and 7 toolbox heights available for a wide range of custom combinations
- Drawer lock-in mechanisms available for all models
- Stationary and mobile versions available

### 5B R2V VERTICAL STORAGE - PAGES 55-60

- This vertical storage system provides easy access to stored items, increases storage density and reclaims floor space
- Compatible with a wide variety of 5S accessories for simple and efficient inventory management
- Drawer lock-in mechanism included with all models
- Optional One-Drawer-at-a-Time System available
- Installs on standard widths of Rousseau R cabinets
- To ensure unit stability, the unit must be anchored to a cabinet

### 5C REEL CABINETS - PAGES 63-66

- A range of reel cabinets available that vary according to number of reels required and layout
- Cabinets include a door and/or panel for easy access and maintenance
- Removable drip tray included

### 5D STORAGE UNITS - PAGES 67-70

- Unit provides secure storage for technicians' personal belongings and for an oil waste container or MultiTek Cart
- Heights available: 48", 76" and 80". Can be used in a workcenter or as a standalone unit
- To ensure unit stability, the unit must be anchored to a workstation, toolbox, storage cabinet or the wall
- Several configurations available: with or without storage for a MultiTek Cart, L Compact Mobile Cabinet or oil waste container

### 5E STORAGE UNITS AND LOCKERS - PAGES 71-72

- Unit provides secure storage for technicians' personal belongings
- Heights available: 48", 76" and 80". Can be used in a workcenter or as a standalone unit
- To ensure unit stability, the unit must be anchored to a workstation, toolbox, storage cabinet or the wall
- Several configurations possible: 1 door or 2 doors with or without ventilation holes

# PRECONFIGURED MODELS - DOUBLE WORKCENTERS

## 12'W (144"W) WORK SURFACE



Customizing a technicians workcenter has never been easier. Simply follow the steps below to configure your bays.

FOR HELP COMPLETING PRODUCT NUMBERS, [SEE PAGE 7](#)

The complete GT-C2153S unit to the left includes the following products:

- |                           |                         |
|---------------------------|-------------------------|
| <b>1</b> GT-W144M1S       | <b>AA</b> GT-M144F2S    |
| <b>2</b> GT-B144B01AC1K1S | <b>SC</b> GT-RDG720401S |
| <b>3</b> GT-U144C31S      |                         |

### 1 TYPE OF SURFACE



Our stainless steel and painted steel tops have a particle board core for excellent impact resistance.

- The stainless steel top adds stylish aesthetics
- The rubber mat is oil resistant and protects the work surface (available for painted and stainless steel tops)

### 2 UNDER THE WORKSURFACE

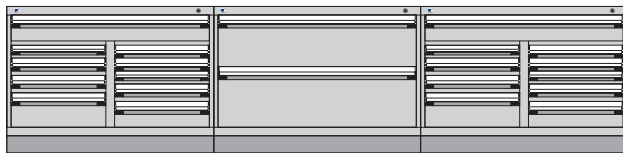

3 Toolboxes

GT-B144001000X3\_

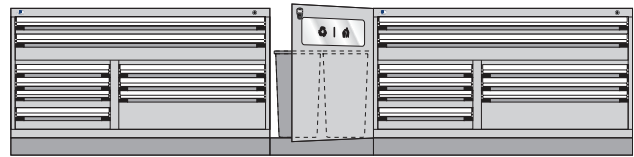

2 Toolboxes - Waste & Recycling Door and Containers

GT-B144B06000K8\_

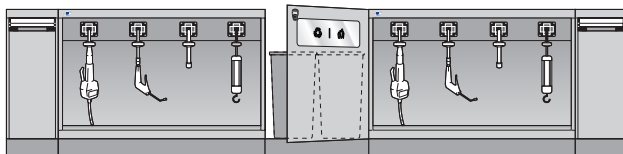

2 Reel Cabinets - Waste & Recycling Door and Containers 2 Lift Control Units

GT-B144A14CR400\_

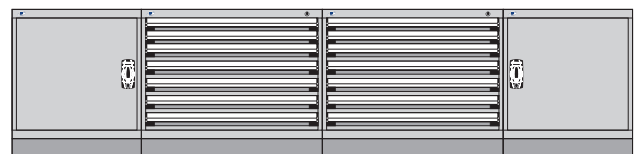

4 Toolboxes

GT-B144001000X2\_

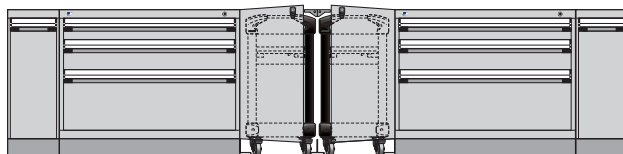

2 Toolboxes - 2 Hideaway Doors - 2 Lift Control Units 2 MultiTek Carts

GT-B144B07AR4A9\_



2 Toolboxes - 2 Lift Control Units

GT-B144B01AR4K9\_

# PRECONFIGURED MODELS - DOUBLE WORKCENTERS

## 3 OVER THE WORKSURFACE

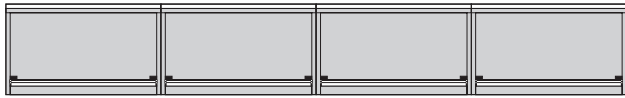

4 Storage Cabinets (wall-mounted)

GT-U14400F

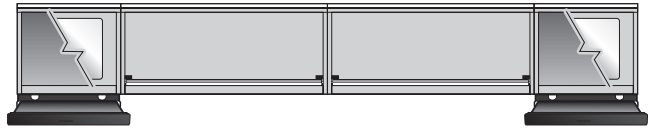

2 Storage Cabinets - 2 Computer Cabinets with Fan (wall-mounted)

GT-U144C\_OF

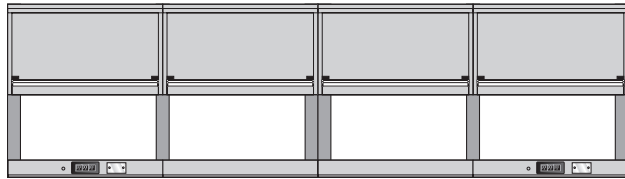

4 Storage Cabinets - Tech Uprights - Panels

GT-U14400\_

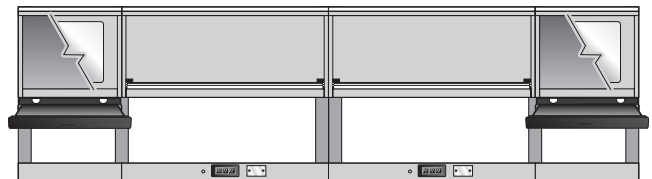

2 Storage Cabinets - 2 Computer Cabinets with Fan - Tech Uprights - Panels

GT-U144C\_

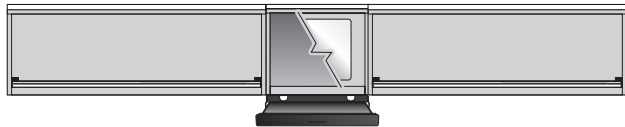

2 Storage Cabinets - Computer Cabinet with Fan (wall-mounted)

GT-U144C\_OF

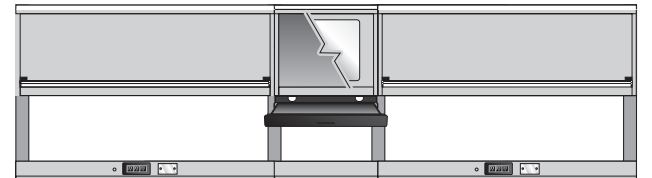

2 Storage Cabinets - Computer Cabinet with Fan - Tech Uprights - Panels

GT-U144C\_

## 4 CENTER

### 4A CENTER - WITH CABINETS



Finishing Panels

GT-M144F1\_

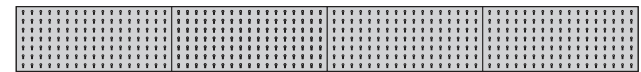

Utility Panels

GT-M144U1\_

### 4B CENTER - WITHOUT CABINETS



Finishing Panels - 19"H Tech Uprights - Panels

GT-M144F119\_

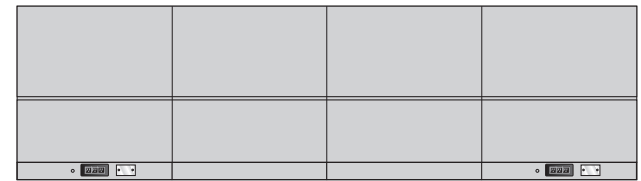

Finishing Panels - 40"H Tech Uprights - Panels

GT-M144F140\_

### 4C CENTER - WITHOUT TECH UPRIGHTS



Power Feed Panels

GT-M144T1\_

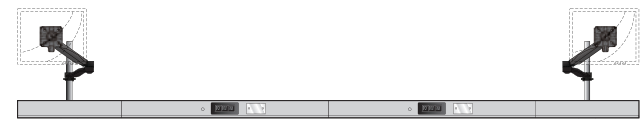

Finishing and Power Feed Panels - Monitor Arms

GT-M144T2\_

## 5 SIDES OF BAYS

5A

TOOLBOXES  
PAGES 44-54

5B

R2V VERTICAL STORAGE  
PAGES 55-60

5C

REEL CABINETS  
PAGES 63-66

5D

STORAGE UNITS  
PAGES 67-70

5E

STORAGE UNITS  
AND LOCKERS  
PAGES 71-72



Not sure what solution you need? Our specialists will help you find a customized solution for your specific needs. Contact us.

# PRECONFIGURED MODELS - DOUBLE WORKCENTERS

## 10'W (120"W) WORK SURFACE

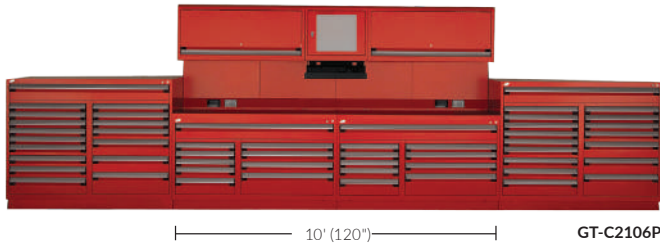

Customizing a technicians workcenter has never been easier. Simply follow the steps below to configure your bays.

FOR HELP COMPLETING  
PRODUCT NUMBERS, **SEE PAGE 7**

The complete GT-C2106P unit to the left includes the following products:

- |                           |                              |
|---------------------------|------------------------------|
| <b>1</b> GT-W120M1P       | <b>4A</b> GT-M120F1P         |
| <b>2</b> GT-B120001000K2P | <b>5A</b> GT-5KKG44004P (2x) |
| <b>3</b> GT-U120C11P      |                              |

### 1 TYPE OF SURFACE



Our stainless steel and painted steel tops have a particle board core for excellent impact resistance.

- The stainless steel top adds stylish aesthetics
- The rubber mat is oil resistant and protects the work surface (available for painted and stainless steel tops)

### 2 UNDER THE WORKSURFACE

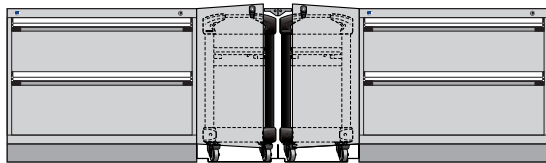

2 Toolboxes - 2 Hideaway Doors - 2 MultiTek Carts  
GT-B120001000A8\_

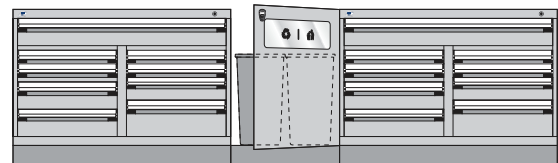

2 Toolboxes - Waste & Recycling Door and Containers  
GT-B120B02000K9\_

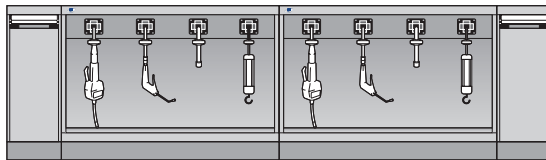

2 Reel Cabinets - 2 Lift Control Units  
GT-B120A01CR400\_

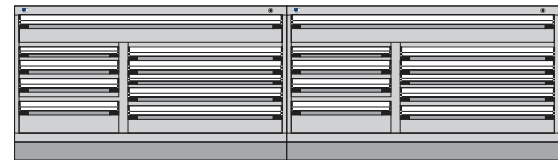

2 Toolboxes  
GT-B120001000K2\_



2 Toolboxes - 2 Hideaway Doors - 2 Lift Control Units - 2 MultiTek Carts  
GT-B120B03AR4C2\_

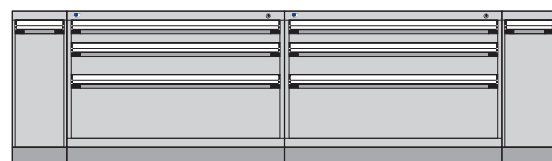

2 Toolboxes - 2 Lift Control Units  
GT-B120B01CR4A9\_

# PRECONFIGURED MODELS - DOUBLE WORKCENTERS

## 3 OVER THE WORKSURFACE



2 Storage Cabinets (wall-mounted)

GT-U120010F

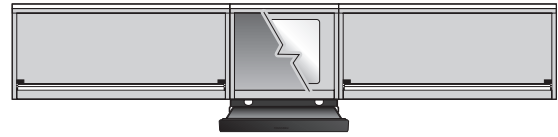

2 Storage Cabinets - Computer Cabinet with Fan (wall-mounted)

GT-U120C\_0F

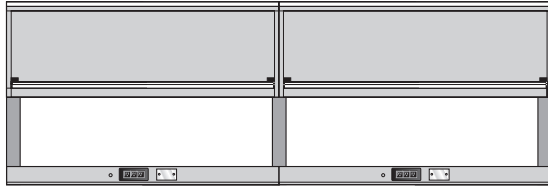

2 Storage Cabinets - Tech Uprights - Panels

GT-U12001\_

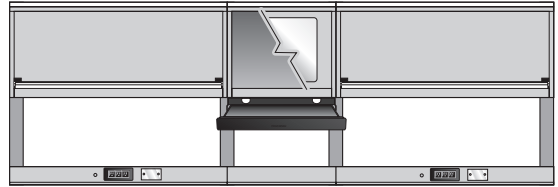

2 Storage Cabinets - Computer Cabinet with Fan - Tech Uprights - Panels

GT-U120C\_

## 4 CENTER

### 4A CENTER - WITH CABINETS



Finishing Panels

GT-M120F1\_



Utility Panels

GT-M120U1\_

### 4B CENTER - WITHOUT CABINETS



Finishing Panels - 19"H Tech Uprights - Panels

GT-M120F119\_



Finishing Panels - 40"H Tech Uprights - Panels

GT-M120F140\_

### 4C CENTER - WITHOUT TECH UPRIGHTS



Power Feed Panels

GT-M120T1\_



Finishing and Power Feed Panels - Monitor Arms

GT-M120T2\_

## 5 SIDES OF BAYS

5A

TOOLBOXES  
PAGES 44-54

5B

R2V VERTICAL STORAGE  
PAGES 55-60

5C

REEL CABINETS  
PAGES 63-66

5D

STORAGE UNITS  
PAGES 67-70

5E

STORAGE UNITS  
AND LOCKERS  
PAGES 71-72



GT-C2020P



GT-C2048S



Not sure what solution you need? Our specialists will help you find a customized solution for your specific needs. Contact us.

# PRECONFIGURED MODELS - DOUBLE WORKCENTERS

## 8'W (96"W) WORK SURFACE

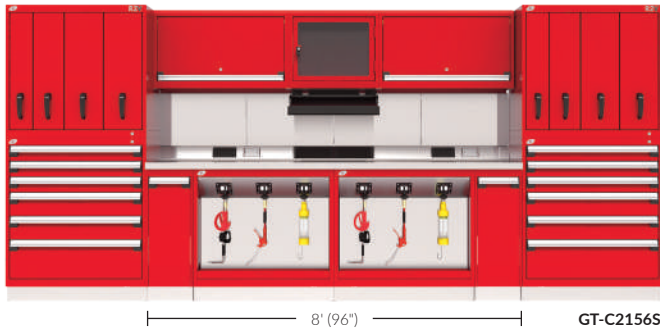

Customizing a technicians workcenter has never been easier. Simply follow the steps below to configure your bays.

FOR HELP COMPLETING  
PRODUCT NUMBERS, [SEE PAGE 7](#)

The complete GT-C2156S unit to the left includes the following products:

- |                           |                              |
|---------------------------|------------------------------|
| <b>1</b> GT-W09600S       | <b>AA</b> GT-M096F1S         |
| <b>2</b> GT-B096A03CR400S | <b>SB</b> GT-5KKG44004P (2x) |
| <b>3</b> GT-U096C11S      |                              |

### 1 TYPE OF SURFACE



GT-W09600P



GT-W09600S



GT-W096M1\_



GT-W096M2\_

Our stainless steel and painted steel tops have a particle board core for excellent impact resistance.

- The stainless steel top adds stylish aesthetics
- The rubber mat is oil resistant and protects the work surface (available for painted and stainless steel tops)

### 2 UNDER THE WORKSURFACE

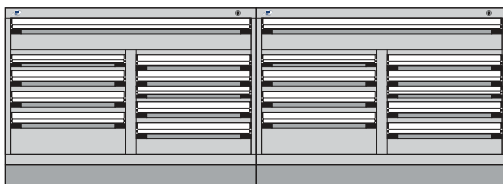

2 Toolboxes

GT-B096001000K2\_

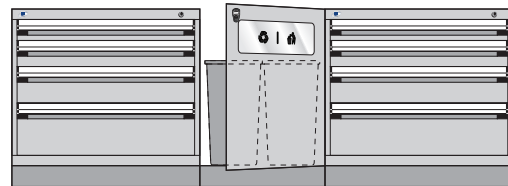

2 Toolboxes - Waste & Recycling Door and Containers

GT-B096B03000A7\_

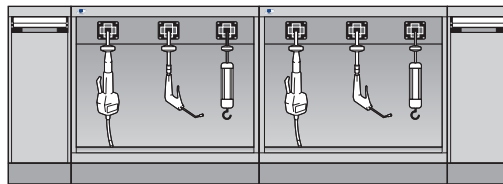

2 Reel Cabinets - 2 Lift Control Units

GT-B096A03CR400\_



4 Toolboxes

GT-B096001000X1\_

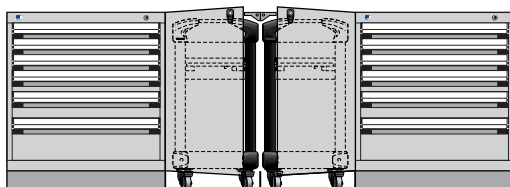

2 Toolboxes - 2 Hideaway Doors - 2 MultiTek Carts

GT-B096B01000A1\_

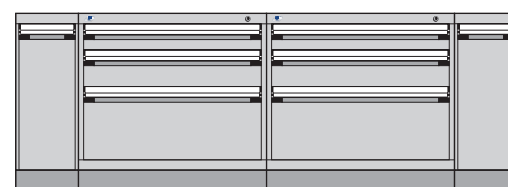

2 Toolboxes - 2 Lift Control Units

GT-B096B01AR4A9\_

# PRECONFIGURED MODELS - DOUBLE WORKCENTERS

## 3 OVER THE WORKSURFACE

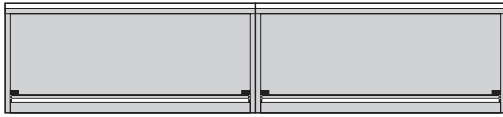

2 Storage Cabinets (wall-mounted)

GT-U09600F

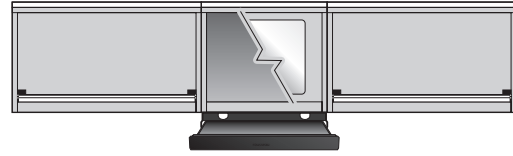

2 Storage Cabinets - Computer Cabinet with Fan (wall-mounted)

GT-U096C\_OF

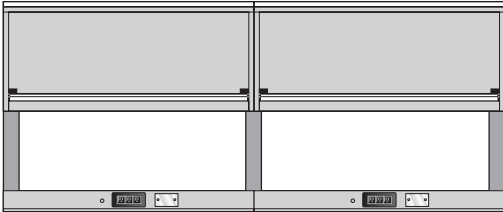

2 Storage Cabinets - Tech Uprights - Panels

GT-U09600\_

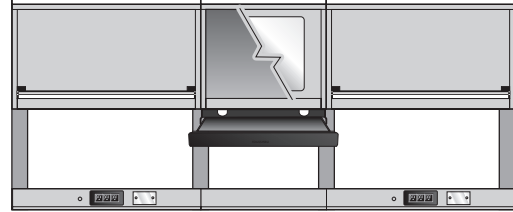

2 Storage Cabinets - Computer Cabinet with Fan - Tech Uprights - Panels

GT-U096C\_

## 4 CENTER

### 4A CENTER - WITH CABINETS



Finishing Panels

GT-M096F1\_



Utility Panels

GT-M096U1\_

### 4B CENTER - WITHOUT CABINETS

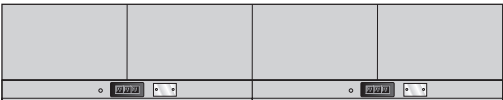

Finishing Panels - 19"H Tech Uprights - Panels

GT-M096F119\_



Finishing Panels - 40"H Tech Uprights - Panels

GT-M096F140\_

### 4C CENTER - WITHOUT TECH UPRIGHTS



Power Feed Panels

GT-M096T1\_



Finishing and Power Feed Panels - Monitor Arms

GT-M096T2\_

## 5 SIDES OF BAYS

5A

TOOLBOXES  
PAGES 44-54

5B

R2V VERTICAL STORAGE  
PAGES 55-60

5C

REEL CABINETS  
PAGES 63-66

5D

STORAGE UNITS  
PAGES 67-70

5E

STORAGE UNITS  
AND LOCKERS  
PAGES 71-72



GT-C2101P



GT-C2036S



Not sure what solution you need? Our specialists will help you find a customized solution for your specific needs. Contact us.

# PRECONFIGURED MODELS - DOUBLE WORKCENTERS

## 7'W (84"W) WORK SURFACE



Customizing a technicians workcenter has never been easier. Simply follow the steps below to configure your bays.

FOR HELP COMPLETING  
PRODUCT NUMBERS, [SEE PAGE 7](#)

The complete GT-C2044S unit to the left includes the following products:

- |                           |                               |
|---------------------------|-------------------------------|
| <b>1</b> GT-W08400S       | <b>4B</b> GT-M084F1402S       |
| <b>2</b> GT-B084001000A8S | <b>5A</b> GT-5GHG34502PS (2x) |

### 1 TYPE OF SURFACE



GT-W08400P



GT-W08400S



GT-W084M1\_



GT-W084M2\_

Our stainless steel and painted steel tops have a particle board core for excellent impact resistance.

- The stainless steel top adds stylish aesthetics
- The rubber mat is oil resistant and protects the work surface (available for painted and stainless steel tops)

### 2 UNDER THE WORKSURFACE

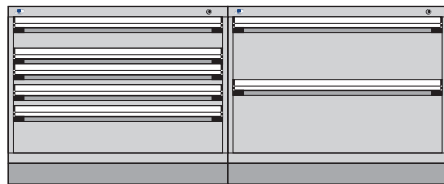

2 Toolboxes

GT-B084001000X2\_

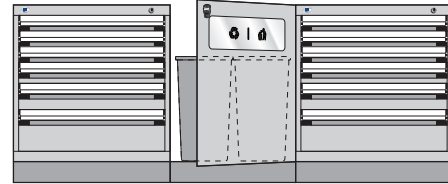

2 Toolboxes - Waste & Recycling Door and Containers

GT-B084B01000A1\_

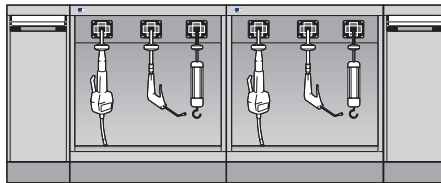

2 Reel Cabinets - 2 Lift Control Units

GT-B084A01CR400\_

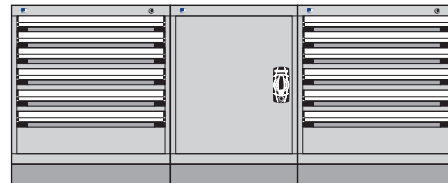

3 Toolboxes

GT-B084001000X1\_

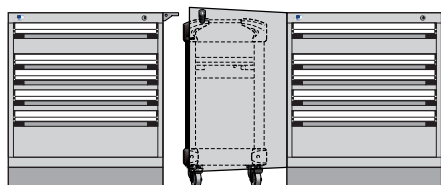

2 Toolboxes - Hideaway Door - MultiTek Cart

GT-B084B02000C3\_

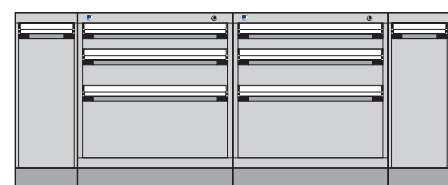

2 Toolboxes - 2 Lift Control Units

GT-B084B01AR4A9\_

# PRECONFIGURED MODELS - DOUBLE WORKCENTERS

## 3 OVER THE WORKSURFACE

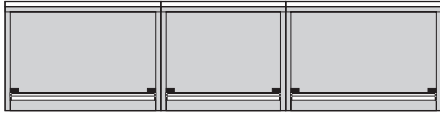

3 Storage Cabinets (wall-mounted)

GT-U08400F

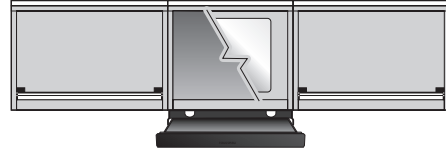

2 Storage Cabinets - Computer Cabinet with Fan (wall-mounted)

GT-U084C\_OF

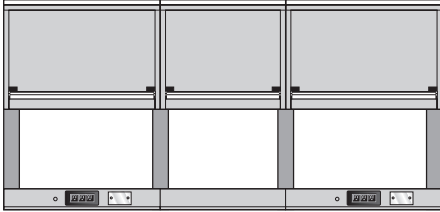

3 Storage Cabinets - Tech Uprights - Panels

GT-U08400\_

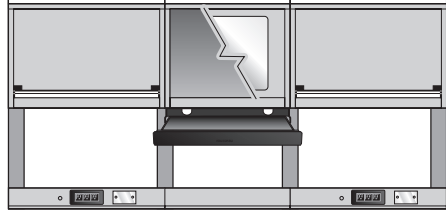

2 Storage Cabinets - Computer Cabinet with Fan - Tech Uprights - Panels

GT-U084C\_

## 4 CENTER

### 4A CENTER - WITH CABINETS



Finishing Panels

GT-M084F1\_

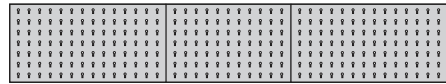

Utility Panels

GT-M084U1\_

### 4B CENTER - WITHOUT CABINETS

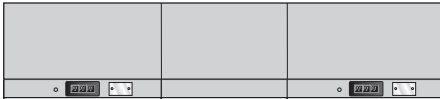

Finishing Panels - 19"H Tech Uprights - Panels

GT-M084F119\_



Finishing Panels - 40"H Tech Uprights - Panels

GT-M084F140\_

### 4C CENTER - WITHOUT TECH UPRIGHTS



Power Feed Panels

GT-M084T1\_



Finishing and Power Feed Panels - Monitor Arms

GT-M084T2\_

## 5 SIDES OF BAYS

5A

TOOLBOXES  
PAGES 44-54

5B

R2V VERTICAL STORAGE  
PAGES 55-60

5C

REEL CABINETS  
PAGES 63-66

5D

STORAGE UNITS  
PAGES 67-70

5E

STORAGE UNITS  
AND LOCKERS  
PAGES 71-72



GT-C2139S



GT-C2038S



Not sure what solution you need? Our specialists will help you find a customized solution for your specific needs. Contact us.

# PRECONFIGURED MODELS - SINGLE WORKCENTERS

## 6'W (72"W) WORK SURFACE



Customizing a technicians workcenter has never been easier. Simply follow the steps below to configure your bays.

FOR HELP COMPLETING  
PRODUCT NUMBERS, **SEE PAGE 7**

The complete GT-C1111S unit to the left includes the following products:

- |                           |                         |
|---------------------------|-------------------------|
| <b>1</b> GT-W072M1S       | <b>4A</b> GT-M072F1S    |
| <b>2</b> GT-B072B01AC1K1S | <b>5A</b> GT-5KKG44002S |
| <b>3</b> GT-U072C11S      |                         |

### 1 TYPE OF SURFACE



GT-W07200P



GT-W07200S



GT-W072M1\_



GT-W072M2\_

Our stainless steel and painted steel tops have a particle board core for excellent impact resistance.

- The stainless steel top adds stylish aesthetics
- The rubber mat is oil resistant and protects the work surface (available for painted and stainless steel tops)

### 2 UNDER THE WORKSURFACE

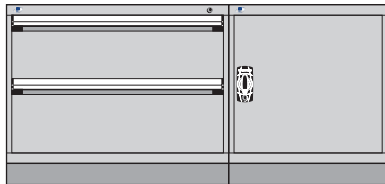

2 Toolboxes

GT-B072001000X1\_

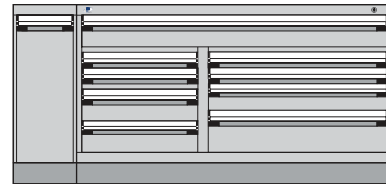

Toolbox - Lift Control Unit

GT-B072B01AR4K9\_

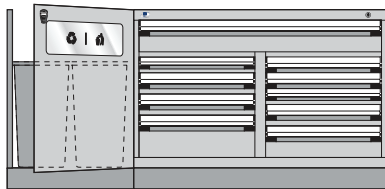

Toolbox - Waste & Recycling Door and Containers

GT-B072B01000K2\_

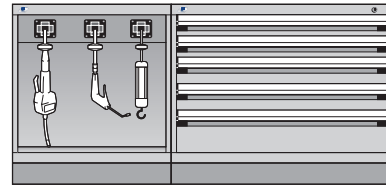

Toolbox - Reel Cabinet

GT-B072A12000A4\_

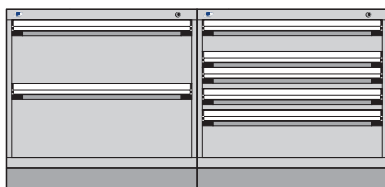

2 Toolboxes

GT-B072001000X3\_

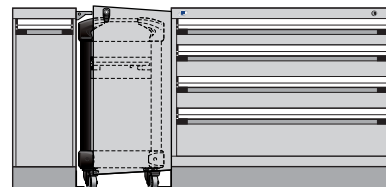

Toolbox - Hideaway Door - Lift Control Unit MultiTek Cart

GT-B072B02AR4C2\_

# PRECONFIGURED MODELS - SINGLE WORKCENTERS

## 3 OVER THE WORKSURFACE

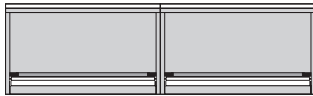

2 Storage Cabinets (wall-mounted)  
GT-U072000F

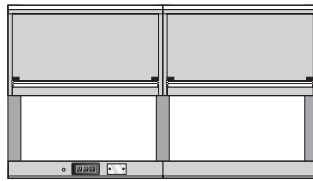

2 Storage Cabinets  
Tech Uprights - Panels  
GT-U07200 \_ \_

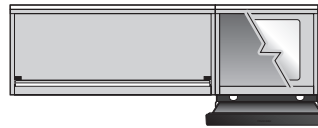

Storage Cabinet - Computer Cabinet  
with Fan (wall-mounted)  
GT-U072C\_OF

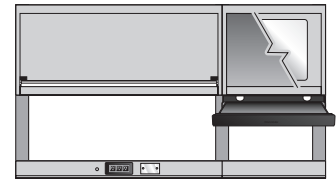

Storage Cabinet - Computer Cabinet  
with Fan - Tech Uprights - Panels  
GT-U072C \_ \_ \_

## 4 CENTER

### 4A CENTER - WITH CABINETS



Finishing Panels  
GT-M072F1\_

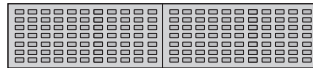

Plastic Bin Panels  
GT-M072L1P

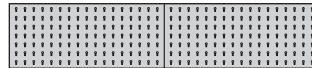

Utility Panels  
GT-M072U1 \_

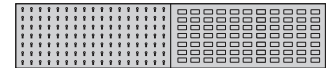

Plastic Bin and Utility Panels  
GT-M072X1P

### 4B CENTER - WITHOUT CABINETS



Finishing Panels - 19"H Tech Uprights - Panels  
GT-M072F119\_ \_



Finishing Panels - 40"H Tech Uprights - Panels  
GT-M072F140\_ \_

### 4C CENTER - WITHOUT TECH UPRIGHTS



Power Feed Panel  
GT-M072T1\_



Cover Panel and Power Feed Panel Monitor Arm  
GT-M072T2\_

## 5 SIDES OF BAYS

5A

TOOLBOXES  
PAGES 44-54

5B

R2V VERTICAL STORAGE  
PAGES 55-60

5C

REEL CABINETS  
PAGES 63-66

5D

STORAGE UNITS  
PAGES 67-70

5E

STORAGE UNITS  
AND LOCKERS  
PAGES 71-72



GT-C1103P



GT-C1110P



GT-C1004P



Not sure what solution you need? Our specialists will help you find a customized solution for your specific needs. Contact us.

# PRECONFIGURED MODELS - SINGLE WORKCENTERS

## 5'W (60"W) WORK SURFACE

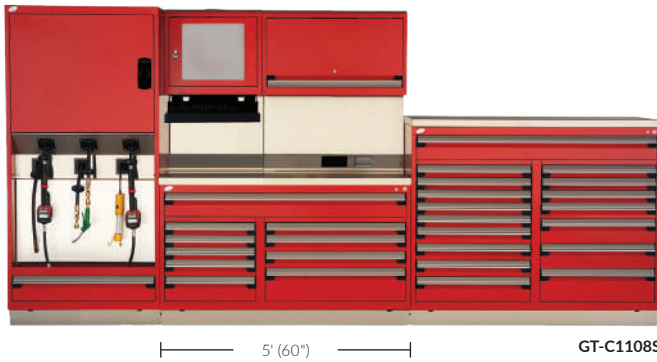

Customizing a technicians workcenter has never been easier. Simply follow the steps below to configure your bays.

FOR HELP COMPLETING  
PRODUCT NUMBERS, **SEE PAGE 7**

The complete GT-C1108S unit to the left includes the following products:

- |                           |                         |
|---------------------------|-------------------------|
| <b>1</b> GT-W060M1S       | <b>4A</b> GT-M060F2S    |
| <b>2</b> GT-B060001000K2S | <b>5A</b> GT-5KKG44004S |
| <b>3</b> GT-U060C11S      | <b>5C</b> GT-REG720601S |

### 1 TYPE OF SURFACE



Our stainless steel and painted steel tops have a particle board core for excellent impact resistance.

- The stainless steel top adds stylish aesthetics
- The rubber mat is oil resistant and protects the work surface (available for painted and stainless steel tops)

### 2 UNDER THE WORKSURFACE

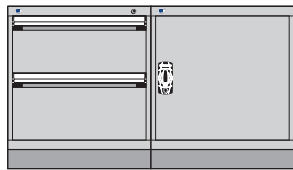

2 Toolboxes

GT-B060001000X1\_

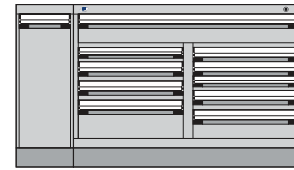

Toolbox - Lift Control Unit

GT-B060B01AR4K2\_

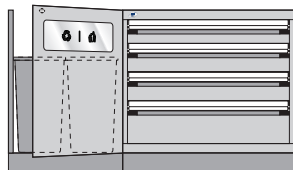

Toolbox - Waste & Recycling - Door and Containers

GT-B060B01000C2\_

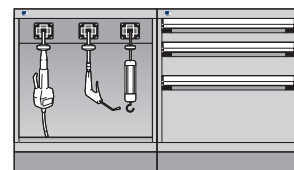

Toolbox - Reel Cabinet

GT-B060A10000A9\_



2 Toolboxes - Lift Control Unit

GT-B060B01AR4X1\_

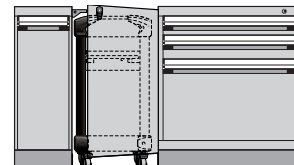

Toolbox - Hideaway Door - Lift Control Unit - MultiTek Cart

GT-B060B03AR4C1\_

# PRECONFIGURED MODELS - SINGLE WORKCENTERS

## 3 OVER THE WORKSURFACE



Storage Cabinet (wall-mounted)  
GT-U060010F

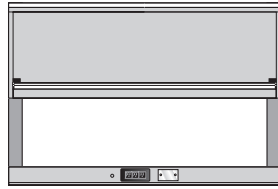

Storage Cabinet - Tech Uprights - Panel  
GT-U06001\_

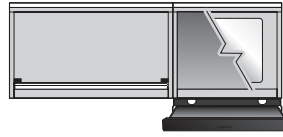

Storage Cabinet - Computer Cabinet  
with Fan (wall-mounted)  
GT-U060C\_0F

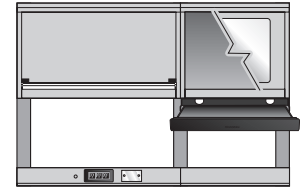

Storage Cabinet - Computer Cabinet  
with Fan - Tech Uprights - Panels  
GT-U060C\_ \_ \_

## 4 CENTER

### 4A CENTER - WITH CABINETS



Finishing Panels  
GT-M060F1\_



Finishing Panels  
GT-M060F2\_

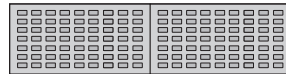

Plastic Bin Panels  
GT-M060L1P



Utility Panels  
GT-M060U1\_

### 4B CENTER - WITHOUT CABINETS



Finishing Panels - 19\"/>

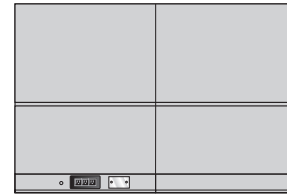

Finishing Panels - 40\"/>

### 4C CENTER - WITHOUT TECH UPRIGHTS



Power Feed Panel  
GT-M060T1\_



Cover Panel and Power Feed Panel - Monitor Arm  
GT-M060T2\_

## 5 SIDES OF BAYS

5A

TOOLBOXES  
PAGES 44-54

5B

R2V VERTICAL STORAGE  
PAGES 55-60

5C

REEL CABINETS  
PAGES 63-66

5D

STORAGE UNITS  
PAGES 67-70

5E

STORAGE UNITS  
AND LOCKERS  
PAGES 71-72



GT-C1020P



GT-C1163S



GT-C1034S



Not sure what solution you need? Our specialists will help you find a customized solution for your specific needs. Contact us.

# PRECONFIGURED MODELS - SINGLE WORKCENTERS

## 4'W (48"W) WORK SURFACE



Customizing a technicians workcenter has never been easier. Simply follow the steps below to configure your bays.

FOR HELP COMPLETING  
PRODUCT NUMBERS, **SEE PAGE 7**

The complete GT-C1053S unit to the left includes the following products:

- |                           |                         |
|---------------------------|-------------------------|
| <b>1</b> GT-W04800S       | <b>4A</b> GT-M048F1S    |
| <b>2</b> GT-B048B04000A7S | <b>5A</b> GT-5ADG44506S |
| <b>3</b> GT-U048000S      |                         |

### 1 TYPE OF SURFACE



GT-W04800P



GT-W04800S



GT-W048M1\_



GT-W048M2\_

Our stainless steel and painted steel tops have a particle board core for excellent impact resistance.

- The stainless steel top adds stylish aesthetics
- The rubber mat is oil resistant and protects the work surface (available for painted and stainless steel tops)

### 2 UNDER THE WORKSURFACE

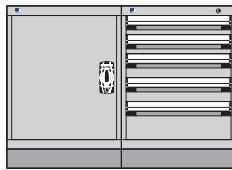

2 Toolboxes

GT-B048001000X3\_

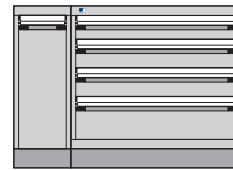

Toolbox - Lift Control Unit

GT-B048B01AR4C2\_

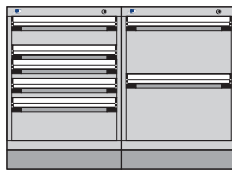

2 Toolboxes

GT-B048001000X4\_

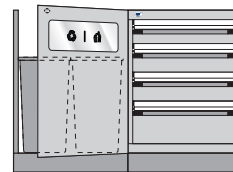

Toolbox - Waste & Recycling Door and Containers

GT-B048B03000C2\_

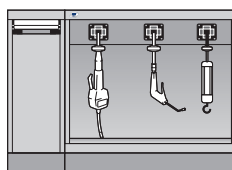

Reel Cabinet - Lift Control Unit

GT-B048A03CR400\_

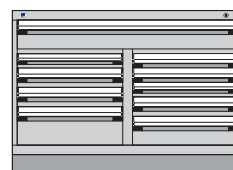

Toolbox

GT-B048001000K2\_

# PRECONFIGURED MODELS - SINGLE WORKCENTERS

## 3 OVER THE WORKSURFACE



Storage Cabinet (wall-mounted)  
GT-U04800F

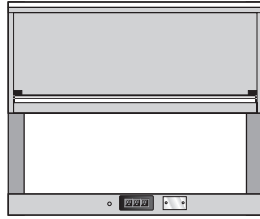

Storage Cabinet - Tech Uprights - Panel  
GT-U04800\_ \_

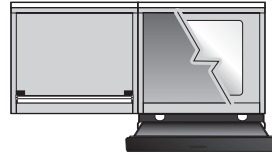

Storage Cabinet - Computer Cabinet  
with Fan (wall-mounted)  
GT-U048C\_0F

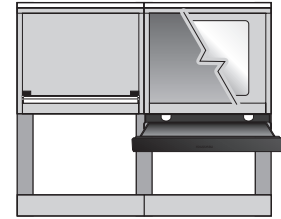

Storage Cabinet - Computer Cabinet  
with Fan - Tech Uprights - Panels  
GT-U048C\_0\_ \_

## 4 CENTER

### 4A CENTER - WITH CABINETS



Finishing Panels  
GT-M048F1\_ \_

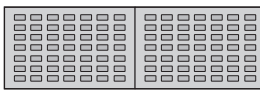

Plastic Bin Panels  
GT-M048L1P

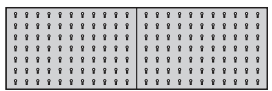

Utility Panels  
GT-M048U1\_ \_

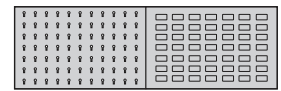

Plastic Bin and Utility Panels  
GT-M048X1P

### 4B CENTER - WITHOUT CABINETS



Finishing Panels - 19\"/>

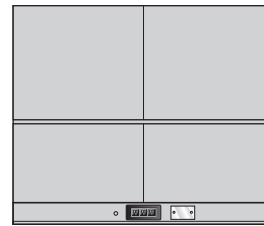

Finishing Panels - 40\"/>

### 4C CENTER - WITHOUT TECH UPRIGHTS



Power Feed Panel  
GT-M048T1\_ \_

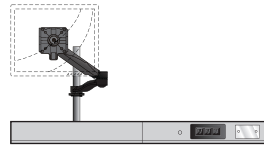

Cover Panel and Power Feed Panel - Monitor Arm  
GT-M048T2\_ \_

## 5 SIDES OF BAYS

5A

TOOLBOXES  
PAGES 44-54

5B

R2V VERTICAL STORAGE  
PAGES 55-60

5C

REEL CABINETS  
PAGES 63-66

5D

STORAGE UNITS  
PAGES 67-70

5E

STORAGE UNITS  
AND LOCKERS  
PAGES 71-72



GT-C1044S



GT-C1142S



GT-C1101P



Not sure what solution you need? Our specialists will help you find a customized solution for your specific needs. Contact us.

# CORNER WORKSTATIONS

## MAXIMIZE SPACE FOR WORK AND STORAGE



Ferrari Lake Forest (IL)

Corner workstations allow for a more complete and integrated layout. They also make use of all available space for work and storage.

- Ergonomic 36" or 40" work surface height
- Standard 30" work surface depth
- Choice of two configurations: with or without cabinet under the work surface
- Leveling glides included in each model for a stable and level workstation
- Designed to be placed against a wall or back to back
- Must be anchored to two cabinets of the same height and depth, one on each side (RA30 or RA35)

To order, choose "WITH" or "WITHOUT" cabinet under the work surface.

Then configure your workstation. Options vary depending on the configuration chosen.

### WITHOUT CABINET UNDER THE WORK SURFACE

0030

Right-angled corner  
(2"W finishing panel)

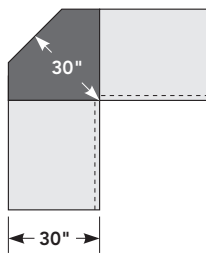

0630

9"W finishing panel

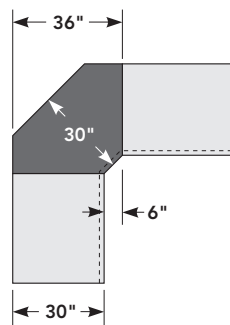

### WITH CABINET UNDER THE WORK SURFACE

1230

L cabinet

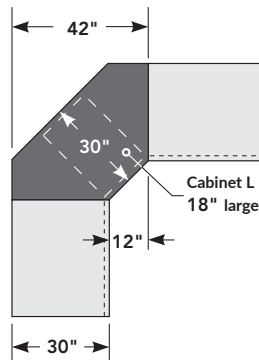

1830

R cabinet

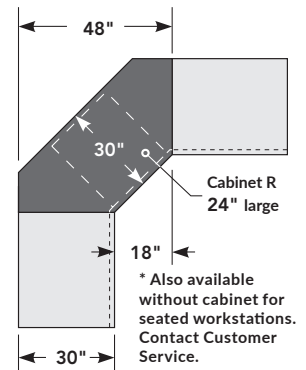

RS-C084X



RS-C002X



RS-C080S



RS-C008X

# CORNER WORKSTATIONS - 0030

## 1 TYPE OF SURFACE

### Choose your work surface

For a neoprene or nitrile rubber mat, choose the desired finish: painted steel (P) or stainless steel (S).



Painted Steel  
RS-W003001P



Stainless Steel  
RS-W003001S



Nitrile Mat - 3/16"  
RS-W0030M3



Neoprene Mat - 1/8"  
RS-W0030M4

## 2 UNDER THE WORKSURFACE

Choose your workstation height and a finish for the base.

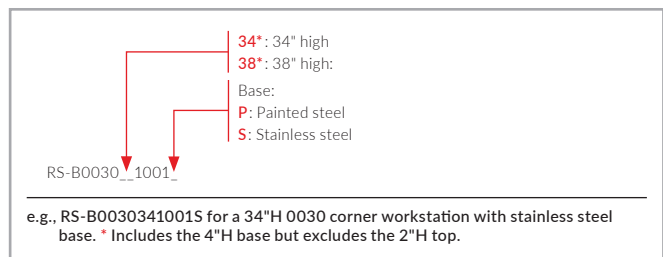
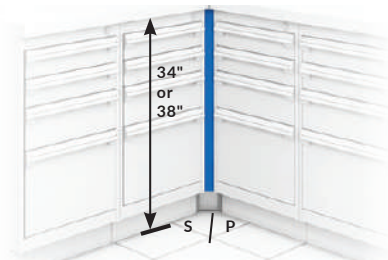

## 3 OVER THE WORKSURFACE

Choose from the following models

Choose a finish for the power feed and finishing panel: painted steel (P) or stainless steel (S).

**A**

Upper finishing panels + power feed panel\*

RS-U0030F14\_

For this model, the power feed panel determines the panel finish, P or S.



Finishing panels + monitor arm and keyboard & mouse tray + power feed panel\*

RS-M0030S1404\_

For this model, the power feed panel determines the panel finish, P or S.

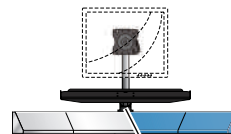

Cover panel + monitor arm and keyboard & mouse tray

RS-M0030T3\_



Power feed panel\*

RS-M0030T4\_

NOTE: \* Includes three 15A power outlets

## 4 CENTER - LOWER PANELS

Choose your panels for model **A** and finish: painted steel (P) or stainless steel (S)



Finishing panels  
RS-M0030F1\_



Utility panels  
RS-M0030U1\_



Plastic bin panels  
RS-M0030L1P



Finishing panels + tablet arm  
RS-M0030S2\_

# CORNER WORKSTATIONS - 0630



RS-J06303404P

## 1 TYPE OF SURFACE

### Choose your work surface

For a neoprene or nitrile rubber mat, choose the desired finish: painted steel (P) or stainless steel (S).



Painted Steel

RS-W063001P



Stainless Steel

RS-W063001S



Nitrile Mat - 3/16"

RS-W0630M3



Neoprene Mat - 1/8"

RS-W0630M4\_

## 2 UNDER THE WORKSURFACE

Choose your workstation height and a finish for the base.

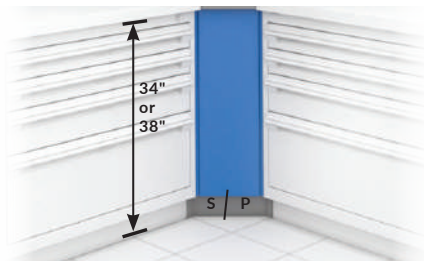

34\*: 34" high  
38\*: 38" high  
Base:  
P: Painted steel  
S: Stainless steel

RS-B0630\_\_1001\_

e.g., RS-B0630341001S for a 34"H 0630 corner workstation with stainless steel base. \* Includes the 4"H base but excludes the 2"H top.

## 3 OVER THE WORKSURFACE

Choose from the following models

Choose a finish for the power feed and finishing panel: painted steel (P) or stainless steel (S).

**A**

Storage cabinet with flipper door + power feed panel<sup>2</sup>

RS-U0630R01\_

**B**

Computer cabinet + cover panel

RS-U0630C10\_

**C**

Upper finishing panels + power feed panel<sup>2</sup>

RS-U0630F11\_

For this model, the power feed panel determines the panel finish, P or S.



Finishing panels + monitor arm and keyboard & mouse tray + power feed panel<sup>1 2</sup>

RS-M0630S1401\_

In this model the power feed panel determines the panel finish, P or S.

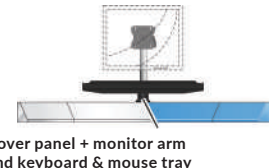

Cover panel + monitor arm and keyboard & mouse tray

RS-M0630T3\_



Power feed panel<sup>2</sup>

RS-M0630T1\_

NOTES: <sup>1</sup>The computer mount is positioned on the right by default in this model.

<sup>2</sup>Includes three 15A power outlets, a knockout for a pneumatic connection and a perforation for installing a telephone or Ethernet jack.

## 4 CENTER - LOWER PANELS

Choose your panels for models **A**, **B** and **C** and finish: painted steel (P) or stainless steel (S).



Finishing panels

RS-M0630F1\_



Utility panels

RS-M0630U1\_

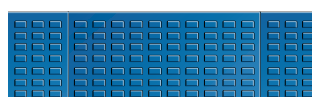

Plastic bin panels

RS-M0630L1P



Finishing panels + tablet arm<sup>3</sup>

RS-M0630S2\_

NOTE: <sup>3</sup>The tablet arm is positioned on the right by default in this model.

# CORNER WORKSTATIONS - 1230

## 1 TYPE OF SURFACE

### Choose your work surface

For a neoprene or nitrile rubber mat, choose the desired finish: painted steel (P) or stainless steel (S).



RS-J12303402X



Painted Steel  
RS-W123001P



Stainless Steel  
RS-W123001S



Nitrile Mat - 3/16"  
RS-W1230M3



Neoprene Mat - 1/8"  
RS-W1230M4\_

## 2 UNDER THE WORKSURFACE

### Choose your workstation and cabinet height and a finish for the base.

Cabinet models include a key lock (L3), attachments bars under the surface and finishing panels. Cabinet dimensions are 18"W x 27"D x 34"H/38"H.

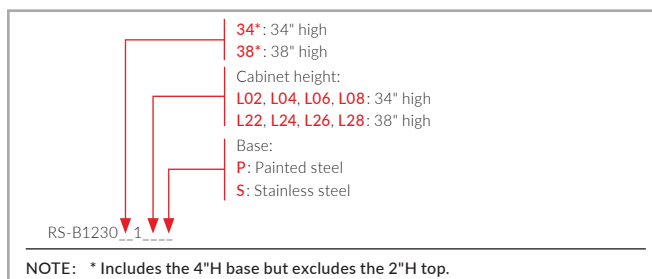
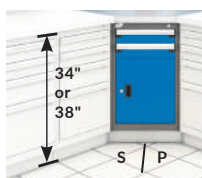

### 34" H CABINETS

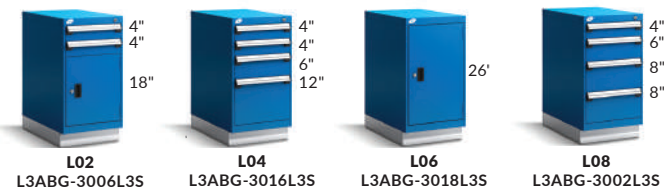

### 38" H CABINETS



## 3 OVER THE WORKSURFACE

### Choose from the following models

Choose a finish for the power feed and finishing panel: painted steel (P) or stainless steel (S).

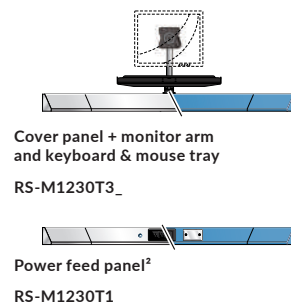
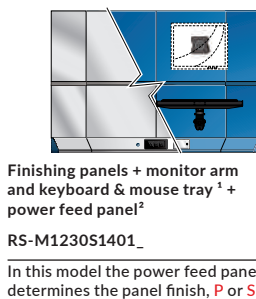
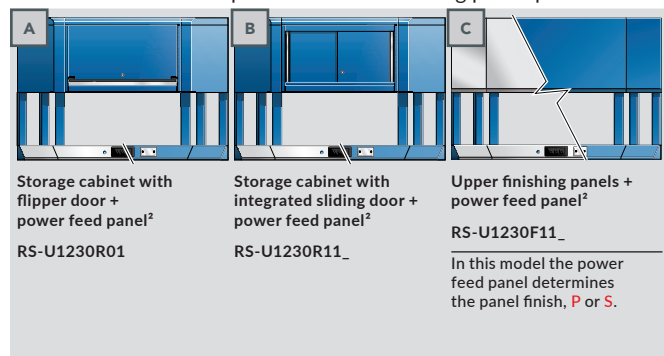

NOTES: <sup>1</sup>The computer mount is positioned on the right by default in this model.  
<sup>2</sup>Includes three 15A power outlets, a knockout for a pneumatic connection and a perforation for installing a telephone or Ethernet jack.

## 4 CENTER - LOWER PANELS

Choose your panels for models **A**, **B** and **C** and panel finish: painted steel (P) or stainless steel (S).

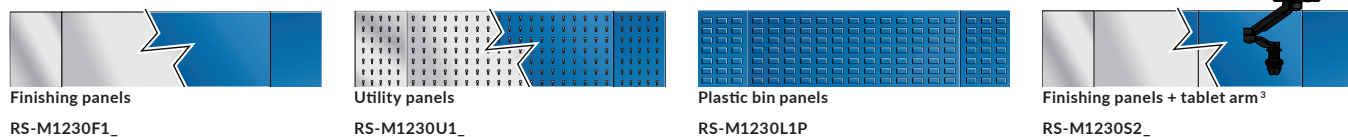

NOTE: <sup>3</sup>The tablet arm is positioned on the right by default in this model.

# CORNER WORKSTATIONS - 1830

## 1 TYPE OF SURFACE

### Choose your work surface

For a neoprene or nitrile rubber mat, choose the desired finish: painted steel (P) or stainless steel (S).



Painted Steel  
RS-W183001P



Stainless Steel  
RS-W183001S



Nitrile Mat - 3/16"  
RS-W1830M3



Neoprene Mat - 1/8"  
RS-W1830M4\_



## 2 UNDER THE WORKSURFACE

### Choose your workstation and cabinet height and a finish for the base.

Cabinet models include a key lock (L3), attachments bars under the surface and finishing panels. Cabinet dimensions are 24"W x 27"D x 34"H/38"H.

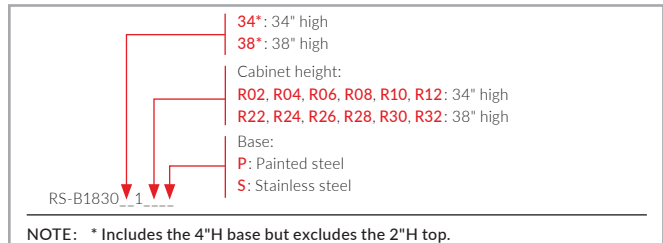
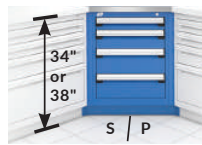

### 34" H CABINETS

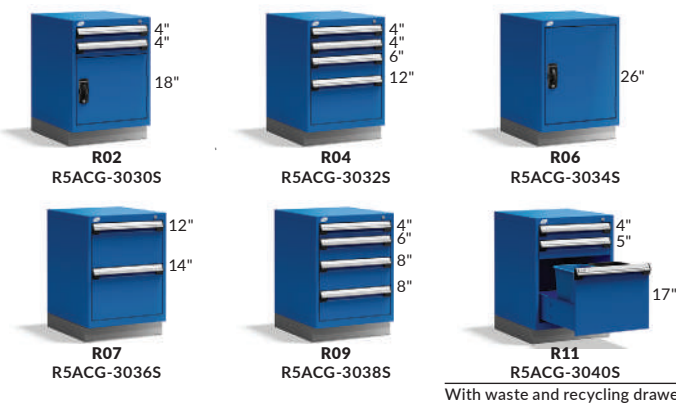

### 38" H CABINETS

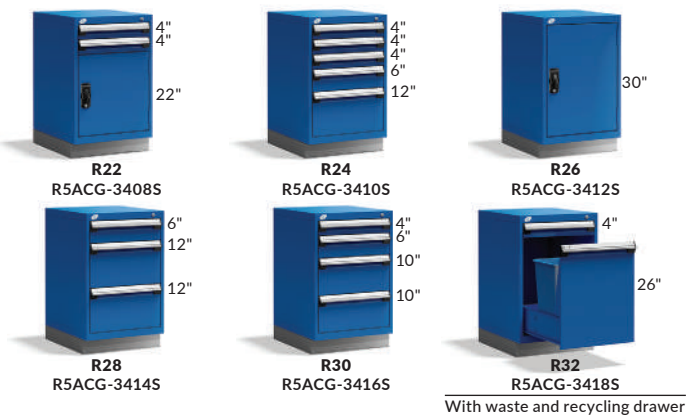

## 3 OVER THE WORKSURFACE

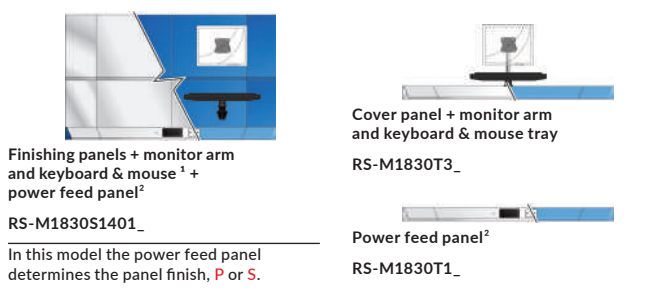
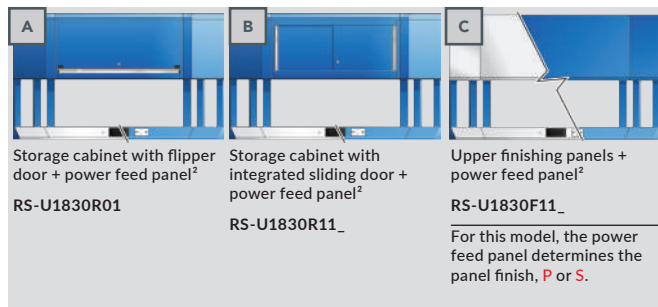

NOTE: For ordering guidelines, (P), (S) and notes 1 & 2, please see page 36.

## 4 CENTER - LOWER PANELS

Choose your panels for models A, B or C and panel finish: painted steel (P) or stainless steel (S).

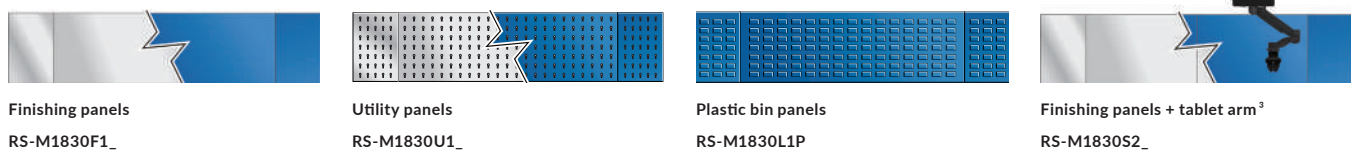

NOTE: <sup>3</sup> The tablet arm is positioned on the right by default in this model.

### LED LIGHT



- Brighter and more energy efficient than a fluorescent tube
- Brightens shaded areas under cabinets
- Color temperature: 5000-6000K (day white)
- Includes a galvanized steel fitting
- Includes a 10' power cord
- The recommended operating temperature for our LED lights is between 5 and 40 °C (41 to 104 °F)
- An optional motion sensor can be added

PRODUCT NO.	CONFIGURATION	LED WIDTH
RD45-2416__	0630 and 1230	21"
RD45-3616__	1830	33"

NOTES To order an LED light with motion sensor, add **MS** to the product number.  
Not compatible with computer cabinets.

### MULTI-PURPOSE HOLDER



- Holds up to four aerosol cans
- Also compatible with drinks cans

PRODUCT NO.	FOR
RC51-120312	With or without top cabinet
RC51-120303	With panel configurations only

### TOOL HOLDERS

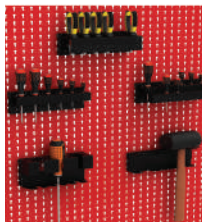

- Variety of hooks and holders available for hanging items and tools. Here are our most popular products:

PRODUCT NO.	
WM9N-01	Single Screwdriver Holder
WM9H-05	Double Back Single Hook
WM9M-01	Pliers Holder
WM9G-200	2" dia. Single Loop Hook

### MULTI-PURPOSE SUPPORT



- Includes a clip to keep documents in place

PRODUCT NO.	FOR
RC54-141202	With or without top cabinet
RC54-1412	With panel configurations only

### SLOPED TOP



- Keeps the workspace clean and safe while reducing clutter
- The top for computer cabinets includes a fan

PRODUCT NO.	CONFIGURATION	FOR
RS31-063008	0630	Storage cabinet
RS31-123008	1230	Storage cabinet
RS31-183008	1830	Storage cabinet
RS32-063008	0630	Computer cabinet

### TABLET ARM



- Compatible with most tablets on the market
- Installs on a lower (15") finishing panel for computer arm (RS81/RS82)
- Compatible tablet sizes:
  - Small: 7 $\frac{1}{8}$ "W to 10"W
  - Large: 9 $\frac{1}{8}$ "W to 12 $\frac{1}{4}$ "W

PRODUCT NO.	FOR
RC58-62-01	Small
RC58-62-02	Large



# TEKZONE WORKSTATION HUTCH

SECURITY – FLEXIBILITY – EFFICIENCY



With the TekZone Workstation Hutch, you can create a personalized and organized workspace.

- The work area it provides is spacious and well lit. Each TekZone Hutch is equipped with an LED light with motion sensor so the workspace lights up as soon as you open the door
- A wide range of accessories helps you to stay tidy by freeing up the work surface, while keeping your essential tools close at hand
- The ingenious door mechanism allows you to open and close the hutch easily, smoothly and safely. With the full-width handle, you can open the door with any hand position. The door is fitted with a lock to secure the contents of the hutch
- An L3 key lock is included with the hutch. For an L50 digital lock or an L100 smart lock, please contact Customer Service

OPEN/CLOSED VIEW



TZ-C044S



## 4 EASY STEPS

In just four steps, we can help you configure your own layout quickly and easily.

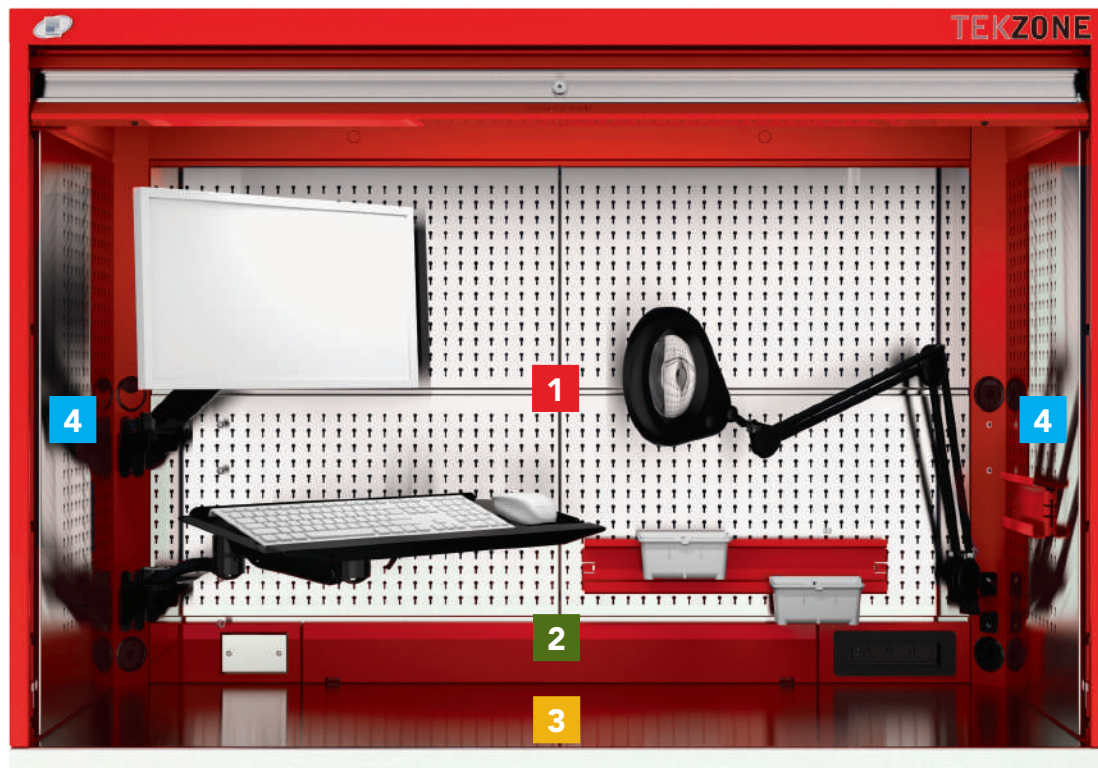

# TEKZONE WORKSTATION HUTCH

## 1 DIMENSIONS AND PANEL TYPES

### UTILITY PANELS

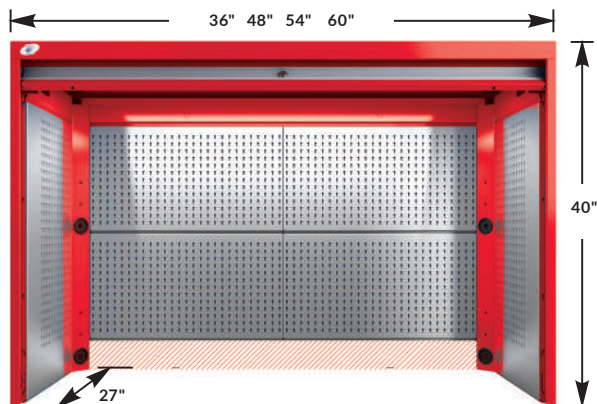

Width:  
**E:** 36"; **G:** 42"; **H:** 48"; **J:** 54"; **K:** 60"  
 Panel types:  
**P:** Painted steel  
**S:** Stainless steel

TZ-U\_G40U002\_L3

### UTILITY AND PLASTIC BINS PANELS

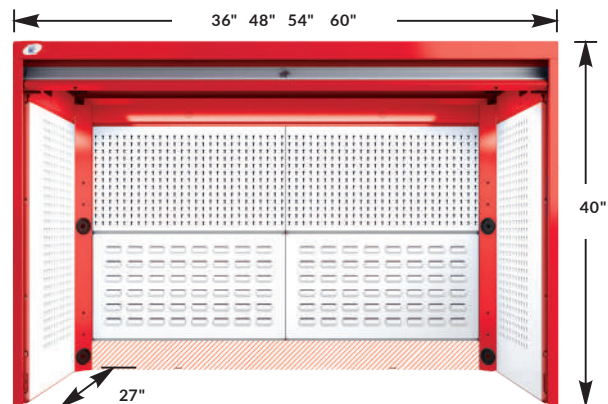

Width:  
**E:** 36"; **G:** 42"; **H:** 48"; **J:** 54"; **K:** 60"  
 Panel types:  
**P:** Painted steel

TZ-U\_G40X002PL3

## 2 POWER FEED PANEL

**3 Power Outlets (15A)**  
 TZ-M0\_ \_ T4\_

**3 Power Outlets (15A), 2 USB Ports**  
 TZ-M0\_ \_ T2\_

Widths:  
**36", 42", 48", 54" and 60"**  
 Panel types:  
**P:** Painted steel  
**S:** Stainless steel

TZ-M0\_ \_ T4\_

**3 Power Outlets (15A), Knockout and Perforation**  
 TZ-M0\_ \_ T1\_

**3 Power Outlets (15A), 2 USB Ports, Knockout and Perforation**  
 TZ-M0\_ \_ T3\_

**Cover Panel**  
 TZ-M0\_ \_ 00\_

## 3 TYPE OF SURFACE

**Slim Painted Steel Top**  
 RH10- \_ \_27 For R cabinets

**Slim Stainless Steel Top**  
 RH11- \_ \_27 For R cabinets

**1 3/4" Painted Steel Top**  
 RC37- \_ \_ \_-02 For R cabinets or GT workstations

**1 3/4" Stainless Steel Top**  
 RC35- \_ \_ \_-02 For R cabinets or GT workstations

**Resistant Rubber Mat (Top must be ordered separately)**  
 RH90- \_ \_ \_ 3/4" oil-resistant nitrile  
 RH91- \_ \_ \_ 1/2" neoprene

Widths:  
**36", 42", 48", 54" and 60"**  
 Depths:  
**27" and 30"**

RH90- \_ \_ \_

# TEKZONE WORKSTATION HUTCH

## 4 ACCESSORIES

### TABLET ARM



- Compatible with most tablets on the market
- The clamps and mount have a non-slip surface to keep the tablet stable
- Includes an articulating arm with two joints
- The articulating arm with two joints provides extra adjustment options
- Tablet can be rotated and tilted
- Compatible tablet sizes:
  - Small: 7 $\frac{3}{8}$ "W to 10"W
  - Large: 9 $\frac{7}{8}$ "W to 12 $\frac{1}{4}$ "W

PRODUCT NO.	FOR
EA64-62-01	Small
EA64-62-02	Large

### LAPTOP ARM



- Holds a laptop, electronic device or any other object
- Tray's usable area: 14"W x 12"D
- Includes an articulating arm with two joints
- The articulating arm with two joints provides extra adjustment options
- Tray can be rotated and tilted

PRODUCT NO.
EA64-42

### LAMP WITH MAGNIFIER AND LED LIGHT

RH50



- Diopter: 5 (2.25x magnification)

PRODUCT NO.	USE
RH50-02	Support and Lamp with magnifier and LED light

### WIRE SPOOL AND ROLL HOLDERS

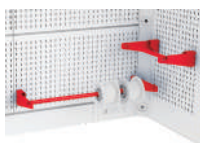

- Hooks onto utility panels at the desired height
- Ideal for wire spools or paper towel rolls
- Tube diameter:  $\frac{3}{4}$ "
- Load capacity: 50lb.

PRODUCT NO.	WIDTH	USE
WM9P-1201	12"	For 27"D side panels
WM9P-2001	20"	For half-width back panels on a 48"W hutch
WM9P-2301	23"	For half-width back panels on a 54"W hutch
WM9P-2601	26"	For half-width back panels on a 60"W hutch For back panels on a 36"W and 42"W hutch

### MONITOR MOUNT AND KEYBOARD & MOUSE ARM



- Holds a computer monitor, keyboard and mouse
- Keyboard tray's usable area: 23 $\frac{3}{8}$ "W x 8 $\frac{1}{2}$ "D
- Includes an articulating arm with a single joint and an articulating arm with two joints
- The articulating arm with two joints provides extra adjustment options
- Compatible with most monitors (max. 21") on the market
- Complies with VESA 75 and 100 monitor mounting standards
- Monitor and tray can be rotated and tilted

PRODUCT NO.	USE
EA64-02	Articulating arm for monitor
EA64-32	Articulated arm for keyboard and mouse

### MONITOR MOUNT



- Supports a monitor compliant with the VESA 75 and 100 standards
- Includes a central cutout for cable management from the rear of the mount
- Two positions: vertical or angled 10° forward to reduce reflections

PRODUCT NO.
RH52-15

### KEYBOARD TRAY



- Hooks onto back utility panels at the desired height
- Unique and heavy-duty design with palm rests
- 25"W to accommodate a keyboard and mouse
- Includes a non-slip protective mat

PRODUCT NO.
RH53-25

### PLASTIC BIN RAIL

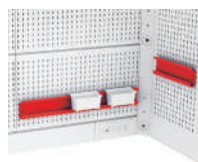

- Hooks onto utility panels at the desired height
- Plastic bins hook onto the rail for efficient storage of small parts
- Compatible with RG20 plastic bins (sold separately)

PRODUCT NO.	WIDTH	USE
WM9C-12	12"	For 27"D side panels
WM9C-20	20"	For half-width back panels on a 48"W hutch
WM9C-23	23"	For half-width back panels on a 54"W hutch
WM9C-26	26"	For half-width back panels on a 60"W hutch For back panels on a 36"W and 42"W hutch

# TEKZONE WORKSTATION HUTCH

## 4 ACCESSORIES

### SLOPED TOP



- Keeps the workspace clean and safe while reducing clutter
- Height: 8"

PRODUCT NO.	W x D
RH89-362708	36" x 27"
RH89-422708	42" x 27"
RH89-482708	48" x 27"
RH89-542708	54" x 27"
RH89-602708	60" x 27"

### CAN HOLDER

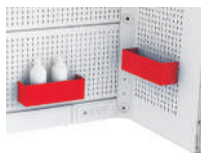

- Hooks onto utility panels at the desired height
- Ideal for storing cans and other containers of different sizes
- Compatible with side and back panels

PRODUCT NO.	W x D x H
WM9D-12	12" x 3" x 4"

### SHELF AND DIVIDERS

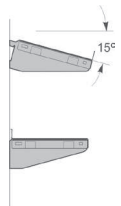

- Hooks onto back utility panels at the desired height
- Can be installed at a right angle or angled 15°
- The shelf is reversible and its edge can act as a back stop for plastic bins and ring binders
- Load capacity: 100lb. (evenly distributed)
- Compatible with SH52-1206 dividers in 2" increments c/c
- Width compatibility:  
36" and 42" hutches: full-width shelf  
48", 54" and 60" hutches: half-width shelf

PRODUCT NO.	WIDTH	COMPATIBILITY
RH60-24__	20"	½ shelf for 48"W hutch
RH60-27__	23"	½ shelf for 54"W hutch
RH60-30__	26"	½ shelf for 60"W hutch
RH61-36__	29"	Shelf for 36"W hutch
RH61-42__	35"	Shelf for 42"W hutch
SH52-1206		Divider

NOTE: Add 08 to the product number for an 8"D shelf and 12 for a 12"D shelf.

### MIDDLE SHELF AND BOTTOM SHELF

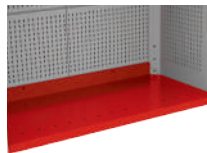
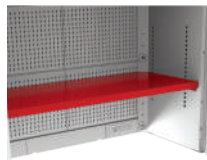

- Full-length and full-depth shelf
- Load capacity: 200lb. (evenly distributed)
- Compatible with SH52-2106 dividers in 3" increments c/c
- Compatible with RH20 and RH21 back utility panels (the panel area right next to the shelf will be unusable)
- Not compatible with RH22/RH23 back plastic bin panels
- RH64 Middle Shelf:**
  - Attaches to RH35 side panels only
  - To add to a preconfigured TZ model, replace the side panels with RH35 side panels
  - Not compatible with the following side panels: RH32 plastic bin panels, RH30/RH31 utility panels and RH28/RH29 finishing panels
- RH65 Bottom Shelf:**
  - A top (see page 41) is required for joining the hutch to the cabinet underneath

PRODUCT NO.	WIDTH	ACTUAL DEPTH
RH__-3627	36"	20 7/16"
RH__-4227	42"	20 7/16"
RH__-4827	48"	20 7/16"
RH__-5457	54"	20 7/16"
RH__-6027	60"	20 7/16"

NOTES: Add 64 to the product number for a middle shelf and 65 for a bottom shelf. RH40/41 power feed panels, RH38/39 cover panels and RH36/37 cable management modules cannot be used with the bottom shelf.

### BATTERY CHARGER SHELF

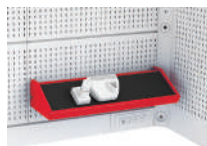

- Hooks onto back utility panels at the desired height
- 25" usable width accommodates several chargers at once
- Includes a non-slip protective mat
- Includes a built-in power strip with six power outlets (15A/120V, with switch, circuit breaker and 15' power cord)
- Includes storage space for cable management

PRODUCT NO.	WIDTH
RH54-26	26"

## TEKZONE: KEEPING YOUR WORKSPACE ORGANIZED AND YOUR TOOLS SECURE



# TOOLBOXES

QUALITY - DURABILITY - VERSATILITY



Richmond Hill Toyota (ON)

Forget everything you think you know about toolboxes because Rousseau toolboxes are in a different league. Those who try them never look back!

You will love their distinctive looks and impressive versatility.

Whether you need just one unit or one hundred, our specialists will help you build your ideal configuration.

## ROUSSEAU: A VAST RANGE OF SOLUTIONS

Many different dimensions available

- Different work surface options
- A choice of 20 standard colors
- Duotone available
- A wide variety of accessories
- An L3 key lock is included on all preconfigured toolbox models. For an L50 digital lock or an L100 smart lock, please contact Customer Service.



## ROUSSEAU TOOLBOXES ARE DESIGNED, DEVELOPED AND MANUFACTURED IN NORTH AMERICA

Choose one of our preconfigured models or build your own.

UNDER THE WORK SURFACE - PAGES 45-47



SIDE - PAGE 48



MOBILE - PAGES 49-51



TOOLBOX ACCESSORIES - PAGES 52-54



DRAWER ACCESSORIES - PAGES 123-124



## 2 UNDER THE WORKSURFACE

Toolboxes can be ordered on their own or as components of workcenters (2 "Under the Work Surface") as featured on pages 20-33.

- Multi-drawer cabinets include stabilizing bars to provide extra rigidity to the housing
- An L3 key lock is included on all preconfigured toolbox models. For an L50 digital lock or an L100 smart lock, please contact Customer Service
- A range of optional accessories are also available, see pages 52-54 and pages 123-124



### SOME OF OUR MOST POPULAR MODELS ARE SHOWN BELOW:

Widths: 1 bank of drawers: 24" (C); 30" (D); 36" (E); 42" (G); 48" (H); 54" (J); 60" (K);  
 3 banks of drawers: 48" (H); 54" (J); 60" (K);  
 4 banks of drawers: 72" (L); 84" (U); 96" (R);

Depth: 27"

Heights: 34", 38" (including the 4"H base)

NOTE	WIDTH
1	Available in 48"W, 54"W and 60"W
2	H (48"W) 1 bank 48"W, 2 banks 24"W
	J (54"W) 1 bank 54"W, 1 bank 24"W, 1 bank 30"W
	K (60"W) 1 bank 60"W, 2 banks 30"W
3	H (48"W) 1 bank 48"W, 2 banks 24"W
	J (54"W) 1 bank 54"W, 1 bank 18"W, 1 bank 36"W
4	K (60"W) 1 bank 60"W, 1 bank 24"W, 1 bank 36"W
	24"W Single integrated swing door
5	30"W+ Double integrated swing doors
	Only available in 24"W and 30"W

NOTE: The 18"W and 24"W banks of drawers are always installed on the left side of a 54"W and 60"W housing.



### 34"H

<p>6 Drawers GT-5A_G30002_</p>	<p>7 Drawers GT-5A_G30004_</p>	<p>6 Drawers GT-5A_G30006_</p>	<p>5 Drawers GT-5A_G30008_</p>
<p>7 Drawers GT-5A_G30010_</p>	<p>4 Drawers GT-5A_G30020_</p>	<p>4 Drawers GT-5A_G30032_</p>	<p>2 Drawers GT-5A_G30042_</p>

# TOOLBOXES

## 2 UNDER THE WORKSURFACE

34"H



3 Drawers  
GT-5A\_G30044\_



2 Drawers - 1 Waste & Recycling Drawer  
GT-5A\_G30046\_ (Note 5)



4 Drawers  
GT-5A\_G30048\_



Integrated Swing Doors - 2 Shelves  
GT-5A\_G30012\_ (Note 4)

NOTE: See page 10 for more details on the Waste & Recycling Drawer.



Integrated Sliding Doors - 2 Shelves  
GT-5A\_G30014\_ (Note 1)



11 Drawers  
GT-5K\_G30002\_ (Note 2)



10 Drawers  
GT-5K\_G30004\_ (Note 3)



7 Drawers  
GT-5K\_G30010\_ (Note 2)



7 Drawers  
GT-5K\_G30008\_ (Note 2)



7 Drawers  
GT-5K\_G30016\_ (Note 2)



9 Drawers  
GT-5K\_G30018\_ (Note 3)



9 Drawers  
GT-5K\_G30020\_ (Note 3)



9 Drawers  
GT-5K\_G30024\_ (Note 2)

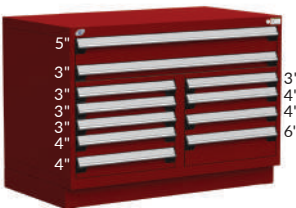

11 Drawers  
GT-5K\_G30026\_ (Note 2)



14 Drawers  
GT-5KUG30004\_

NOTE: Width: 84"

## 2 UNDER THE WORKSURFACE

38" H



5 Drawers

GT-5A\_G34006\_



5 Drawers

GT-5A\_G34008\_



3 Drawers

GT-5A\_G34010\_



4 Drawers

GT-5A\_G34012\_



10 Drawers

GT-5K\_G34002\_ (Note 2)



8 Drawers

GT-5K\_G34004\_ (Note 2)



8 Drawers

GT-5K\_G34006\_ (Note 2)



9 Drawers

GT-5K\_G34008\_ (Note 3)



Integrated Swing Doors - 2 Shelves

GT-5A\_G34014\_ (Note 4)



Integrated Sliding Doors - 2 Shelves

GT-5A\_G34018\_ (Note 1)



10 Drawers

GT-5K\_G34010\_ (Note 3)

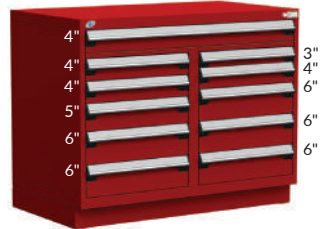

11 Drawers

GT-5K\_G34012\_ (Note 3)



14 Drawers

GT-5KLG34002\_



14 Drawers

GT-5KUG34002\_



14 Drawers

GT-5KRG34002\_

NOTE: Width: 72"

NOTE: Width: 84"

NOTE: Width: 96"

# TOOLBOXES

## 5A SIDES OF BAYS

Toolboxes can be ordered on their own or as components of a workcenter as featured on [pages 20-33](#).

- Multi-drawer cabinets include stabilizing bars to provide extra rigidity to the housing
- An L3 key lock is included on all preconfigured toolbox models. For an L50 digital lock or an L100 smart lock, please contact Customer Service
- A range of optional accessories are also available, see [pages 49-52](#) and [pages 119-120](#)



### SOME OF OUR MOST POPULAR MODELS ARE SHOWN BELOW:

Widths: 1 bank of drawers: 24" (C); 30" (D); 36" (E); 42" (G); 48" (H); 54" (J); 60" (K);  
 3 banks of drawers: 48" (H); 54" (J); 60" (K);  
 4 banks of drawers: 96" (R);

Depth: 27"

Heights: 42", 48", 62" (including the 4"H base)

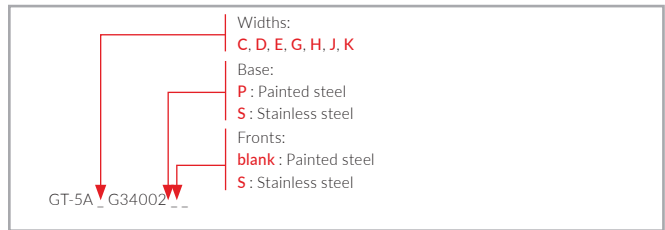

NOTE	WIDTH	
	<b>H</b> (48"W)	1 bank 48"W, 2 banks 24"W
1	<b>J</b> (54"W)	1 bank 54"W, 1 bank 18"W, 1 bank 36"W
	<b>K</b> (60"W)	1 bank 60"W, 2 banks 30"W

NOTE: The 18"W and 24"W banks of drawers are always installed on the left side of a 54"W or 60"W housing.

### 42" H



12 Drawers  
 GT-5K \_ G38002 \_ (Note 1)

### 48" H



9 Drawers  
 GT-5A \_ G44010 \_



15 Drawers  
 GT-5K \_ G44010 \_ (Note 1)



17 Drawers  
 GT-5K \_ G44004 \_ (Note 1)

### 48" H



16 Drawers  
 GT-5K \_ G44008 \_ (Note 1)



8 Drawers  
 GT-5A \_ G44008 \_

### 62" H



15 Drawers  
 GT-5K \_ G58004 \_ (Note 1)



14 Drawers  
 GT-5K \_ G58006 \_ (Note 1)

Toolboxes can be ordered on their own or as components of a workcenter as featured on [pages 20-33](#).

- An L3 key lock is included on all preconfigured toolbox models. For an L50 digital lock or an L100 smart lock, please contact Customer Service
- Preconfigured models include 6" polyurethane casters (total height: 7 1/2"), including two rigid and two swivel casters with total-lock brakes. 4" polyurethane casters are also available
- A range of optional accessories are also available, see [pages 52-54](#) and [pages 123-124](#)



### SOME OF OUR MOST POPULAR MODELS ARE SHOWN BELOW:

Widths: 1 bank of drawers: 30" (D); 36" (E); 48" (H); 54" (J); 60" (K);  
 3 banks of drawers: 48" (H); 54" (J); 60" (K);  
 4 banks of drawers: 72" (L); 78" (V); 84" (U); 96" (R); 108" (S);

Depth: 27"  
 Heights: 37 1/2", 41 1/2", 45 1/2" (including casters)



NOTE	WIDTH	
1	H (48")	1 bank 48"W, 2 banks 24"W
	J (54")	1 bank 54"W, 1 bank 18"W, 1 bank 36"W
	K (60")	1 bank 60"W, 1 bank 24"W, 1 bank 36"W

NOTE: The 18"W and 24"W banks of drawers are always installed on the left side of a 54"W or 60"W housing.

### 37 1/2" H



6 Drawers

GT-5B \_ G30002P \_



5 Drawers

GT-5B \_ G30004P \_



4 Drawers

GT-5B \_ G30008P \_



10 Drawers

GT-5G \_ G30006P \_ (Note 1)

### 41 1/2" H



7 Drawers

GT-5G \_ G34006P \_ (Note 1)



10 Drawers

GT-5G \_ G34004P \_ (Note 1)

### 45 1/2" H



12 Drawers

GT-5G \_ G38010P \_ (Note 1)



16 Drawers

GT-5G \_ G38002P \_ (Note 1)

# TOOLBOXES

## MOBILE

37 1/2" H



6 Drawers  
GT-5G\_G30010P\_(Note 1)

41 1/2" H



9 Drawers  
GT-5G\_G34008P\_(Note 1)

45 1/2" H



9 Drawers  
GT-5G\_G38012P\_(Note 1)



11 Drawers  
GT-5G\_G38014P\_(Note 1)

37 1/2" H



12 Drawers  
GT-5GLG30002P\_

NOTE: Width: 72"



13 Drawers  
GT-5GUG30002P\_

NOTE: Width: 84"



13 Drawers  
GT-5GRG30002P\_

NOTE: Width: 96"

41 1/2" H



14 Drawers  
GT-5GVG34002P\_

NOTE: Width: 78"



14 Drawers  
GT-5GLG34002P\_

NOTE: Width: 72"



13 Drawers  
GT-5GRG34002P\_

NOTE: Width: 96"

45 1/2" H



15 Drawers  
GT-5GVG38002P\_

NOTE: Width: 78"



13 Drawers  
GT-5GRG38002P\_

NOTE: Width: 96"



16 Drawers  
GT-5GSG38002P\_

NOTE: Width: 108"

### HANGING SIDE CABINET - SIDE ACCESS



- For additional storage space in your mobile toolbox, consider our hanging side cabinets.
- Adjustable shelves in 1" increments c/c
- Available with bottom and adjustable shelves
- Both shelf types are compatible with SH52 dividers
- For 27"D toolboxes
- Load capacity: 600lb. per cabinet
- Choice of door. Complete the product number as follows:
  - **01**: Solid door
  - **02**: Polycarbonate door

W x D x H	PRODUCT NO.	NO. OF ADJUSTABLE SHELVES (RD05)
27" x 14" x 24"	R5QPA-24__	-
27" x 14" x 28"	R5QPA-28__	1
27" x 14" x 30"	R5QPA-30__	1
27" x 14" x 34"	R5QPA-34__	1
27" x 14" x 38"	R5QPA-38__	2

### POLYURETHANE CASTERS



- Polyurethane casters provide ultra-quiet and excellent maneuverability without marking floors
- 4" and 6" casters available in rigid, swivel and swivel with total-lock brake, with 440lb. and 1,100lb. load capacity per wheel respectively
- An optional directional locking pedal is available for swivel casters (4" and 6") for better control over long distances

PRODUCT NO.	CASTER TYPE	HEIGHT	ACTUAL HEIGHT
RB81-01	Rigid	4 "	5 1/8"
RB81-02	Swivel	4 "	5 1/8"
RB81-03	Swivel with total-lock brake	4 "	5 1/8"
RB84-01	Rigid	6 "	7 1/2"
RB84-02	Swivel	6 "	7 1/2"
RB84-03	Swivel with total-lock brake	6 "	7 1/2"
RB8E-02	Swivel caster directional locking kit		

NOTE: Directional locking pedals are sold in pairs.

### SIDE HANDLE



- Wide-grip handle for easier toolbox handling

PRODUCT NO.	ACTUAL DEPTH OF HANDLE
RB90-27	24"

### LOCK-IN MECHANISM



Activates when handle is lifted



Closes with a simple push

- Each drawer includes a lock-In mechanism that automatically activates when the drawer is opened
- Stops drawer from opening on its own

PRODUCT NO.
A

### FOLDAWAY SHELF



- Provides an additional work surface
- Folds easily to the side when not in use
- Includes a protective neoprene surface

PRODUCT NO.	W x D
RC00-152701	15" x 27"

### SIDE AND BACK STOP FOR FOLDAWAY SHELF



- Prevents parts and tools from falling
- Height: 1"

PRODUCT NO.	WIDTH
RC01-15	15"
RC01-27	27"



Troy High School (IL)

# TOOLBOXES

## TOOLBOX ACCESSORIES



### STAINLESS STEEL TOP



- Acts as a work surface and protects the top of the cabinet from impacts
- Particle board top with stainless steel cover (#4 brushed finish)
- Excellent chemical resistance
- Excellent corrosion resistance
- Welded corners for an attractive appearance
- Available in 12ga or 16ga steel (12ga steel top provides better impact resistance)
- 12ga top thickness: 1<sup>13</sup>/<sub>16</sub>"
- 16ga top thickness: 1<sup>3</sup>/<sub>4</sub>"

PRODUCT NO.	W × D
RC35-2427-__	24" × 27"
RC35-3027-__	30" × 27"
RC35-3627-__	36" × 27"
RC35-4227-__	42" × 27"
RC35-4827-__	48" × 27"
RC35-5427-__	54" × 27"
RC35-6027-__	60" × 27"

NOTE: Complete number with **12** for a 12-gauge steel top.

### MARINE EDGE STAINLESS STEEL TOP

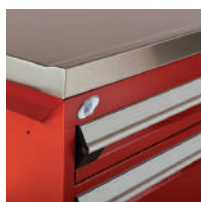

- The edge stops hardware and liquids from falling off
- Acts as a work surface and protects the top of the cabinet from impacts
- Particle board top with stainless steel cover (#4 brushed finish)
- Excellent chemical resistance
- Excellent corrosion resistance
- Welded corners for an attractive appearance
- Available in 12ga or 16ga steel (12ga steel top provides better impact resistance)
- 12ga top thickness: 1<sup>13</sup>/<sub>16</sub>" and 2" edge
- 16ga top thickness: 1<sup>3</sup>/<sub>4</sub>" and 1<sup>13</sup>/<sub>16</sub>" edge

PRODUCT NO.	W × D
RC35-2427-__M	24" × 27"
RC35-3027-__M	30" × 27"
RC35-3627-__M	36" × 27"
RC35-4227-__M	42" × 27"
RC35-4827-__M	48" × 27"
RC35-5427-__M	54" × 27"
RC35-6027-__M	60" × 27"

NOTES: Add **12** to the product number for a 12ga steel top, or **16** for a 16ga steel top.  
Not compatible with the nitrile or neoprene rubber mat

We have a wide range of accessories so you can gain maximum benefit from your toolbox. Take a look at our selection of tops, doors, stacking cabinets, and other useful add-ons.

### PAINTED STEEL TOP

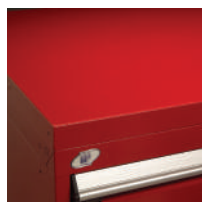

- Acts as a work surface and protects the top of the cabinet from impacts
- Particle board top with painted steel cover
- Welded corners for an attractive appearance
- Thickness: 1<sup>3</sup>/<sub>4</sub>"

PRODUCT NO.	W × D
RC37-2427	24" × 27"
RC37-3027	30" × 27"
RC37-3627	36" × 27"
RC37-4227	42" × 27"
RC37-4827	48" × 27"
RC37-5427	54" × 27"
RC37-6027	60" × 27"

### PAINTED STEEL COVER

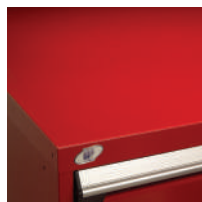

- Adds a protective work surface to the top of the toolbox
- Welded corners for an attractive appearance
- Compatible with the toolbox lock

PRODUCT NO.	W × D
RC38-2427L	24" × 27"
RC38-3027L	30" × 27"
RC38-3627L	36" × 27"
RC38-4227L	42" × 27"
RC38-4827L	48" × 27"
RC38-5427L	54" × 27"
RC38-6027L	60" × 27"

### STAINLESS STEEL COVER



- Adds a protective work surface to the top of the toolbox
- Stainless steel adds stylish aesthetics
- Excellent chemical resistance
- Excellent corrosion resistance
- Welded corners for an attractive appearance
- Compatible with the toolbox lock

PRODUCT NO.	W × D
RC39-2427L	24" × 27"
RC39-3027L	30" × 27"
RC39-3627L	36" × 27"
RC39-4227L	42" × 27"
RC39-4827L	48" × 27"
RC39-5427L	54" × 27"
RC39-6027L	60" × 27"

### NITRILE RUBBER MAT



- Nitrile mat with excellent hydrocarbon and shock resistance
- Thickness: 3/16"

PRODUCT NO.	W×D
RG48-2427	24"×27"
RG48-3027	30"×27"
RG48-3627	36"×27"
RG48-4227	42"×27"
RG48-4827	48"×27"
RG48-5427	54"×27"
RG48-6027	60"×27"

NOTE: Not compatible with the marine edge stainless steel top.

### NEOPRENE RUBBER MAT



- Neoprene mat for protecting the work surface
- Thickness: 1/8"

PRODUCT NO.	W×D
RG45-2427	24"×27"
RG45-3027	30"×27"
RG45-3627	36"×27"
RG45-4227	42"×27"
RG45-4827	48"×27"
RG45-5427	54"×27"
RG45-6027	60"×27"

NOTE: Not compatible with marine edge stainless steel top.

### ADJUSTABLE KICK PLATE FOR LEVELING GLIDES



- Provides an immaculate finish
- Prevents dust from entering
- Available in stainless steel only
- Please contact your customer service representative for more details

### LEVELING GLIDES



- For easy height adjustment and leveling of toolbox without removing drawers (1 1/2" to 2" from the ground)
- Compatible with toolbox bases
- Sold in packs of 4

PRODUCT NO.
RA74-01

### SIDE UTILITY PANEL



- Maximizes toolbox storage space
- Installs on the sides of toolboxes
- Compatible with all WM9\_ hooks and holders, [see page 119](#)

PRODUCT NO.	DEPTH
RC02-27_	27"

NOTES: Complete the product number with the housing height required: 28", 30", 34", 38", 44", 58".

Full height installation only.

Not compatible with RC00 foldaway shelves.

### BUMPERS FOR TOOLBOXES



- Protects toolboxes from bumps and damage
- Protection kit for all four corners of toolboxes
- Vertical bumpers and endcaps made from resistant soft PVC
- Quick and easy installation with double-sided adhesive tape
- Tool-free installation

PRODUCT NO.	COMPATIBLE WITH
RB9J-_ _01	RA30/RA35 toolbox
RB9J-_ _02	RA30/RA35 toolbox and RD01 side cabinet
RB9J-_ _03	RA30/RA35 toolbox and 1 RC02/RC04 side panel
RB9J-_ _04	RA30/RA35 toolbox and 2 RC02/RC04 side panels

NOTES: Complete the product number with the housing height required: 28", 30", 34", 38", 44", 58".

Not compatible with RC00 foldaway shelves.

### SIDE PLASTIC BIN PANEL



- Maximizes toolbox storage space
- Holds RG20 plastic bins, [see page 121](#)
- Installs on the sides of toolboxes
- Compatible with all commercially available brands of plastic bins with a hanging lip

PRODUCT NO.	DEPTH
RC04-27_	27"

NOTES: Complete the product number with the housing height required: 28", 30", 34", 38", 44", 58".

Full height installation only.

Not compatible with RC00 foldaway shelves.



# TOOLBOXES

## TOOLBOX ACCESSORIES

### STACKING CABINET



- For storage of large and bulky items, choose a stacking cabinet.
- Shelves are height adjustable in 1" increments c/c and include an edge that prevents items from falling
- Housing heights available: 24" and 30"
- Available with or without doors (solid steel or polycarbonate)
- A range of dimensions available

PRODUCT NO.	W x D
R5HDG-___	30" x 27"
R5HEG-___	36" x 27"
R5HHG-___	48" x 27"
R5HJG-___	54" x 27"
R5HKG-___	60" x 27"

DOOR TYPE	CABINET WIDTHS				
	30"	36"	48"	54"	60"
00 Without door	X	X	X	X	X
01 Single integrated door	X	X			
02 Single integrated polycarbonate door	X	X			
03 Double integrated doors	X	X	X	X	X
04 Double integrated polycarbonate doors	X	X	X	X	X
05 Double doors with frame	X	X	X	X	X
06 Double polycarbonate doors with frame	X	X	X	X	X
07 Integrated sliding doors			X	X	X
08 Integrated sliding polycarbonate doors			X	X	X
09 Sliding doors with frame			X	X	X
10 Sliding polycarbonate doors with frame			X	X	X

NOTE: When ordering, specify the housing height and type of door required: e.g., R5HEG-24 03 for a 36"W x 27"D x 24"H cabinet with double integrated doors.

### SLOPED TOP



- Keeps the workspace clean and tidy while reducing clutter
- 16° slope angle
- Height: 8"

PRODUCT NO.	W x D
RC31-362708	36" x 27"
RC31-422708	42" x 27"
RC31-482708	48" x 27"
RC31-542708	54" x 27"
RC31-602708	60" x 27"

### DRAWER WITH STAINLESS STEEL FRONT



- Adds stylish aesthetics to workstations and toolboxes
- Excellent chemical and corrosion resistance
- #4 brushed finish

Drawer widths:	18", 24", 30", 36", 42", 48", 54", 60"
Drawer heights:	03", 04", 05", 06", 07", 08", 09", 10", 12", 14"

RF35-\_\_\_27"

NOTE: Order an RA30 or RA35 housing and RF35 drawers with stainless steel fronts.

### DOORS



- Doors are ideal for secure and discrete storage.
- Available in the following combinations: single or double (double door can be sliding), polycarbonate or solid steel
- All door models include an L3 key lock
- The L50 digital lock option or the L100 smart lock is compatible with swing doors. Please contact our customer service.

PRODUCT NO.	TYPE	SURFACE
RB62	Single integrated	Steel
RB67	Double integrated	Steel
RB75	Double with frame	Steel
RB50	Integrated sliding	Steel
RB55	Sliding with frame	Steel
RB61	Single integrated	Polycarbonate
RB66	Double integrated	Polycarbonate
RB76	Double with frame	Polycarbonate
RB51	Integrated sliding	Polycarbonate
RB56	Sliding with frame	Polycarbonate

### L50 DIGITAL LOCK



- Simple, fast and easy to use
- No key required
- Up to 20 different users
- 4-to 8-digit access codes
- Retrofits on existing Rousseau R or L cabinets with drawers
- Simplifies access management to drawers
- Can be used in all configurations of cabinets with drawers
- Compatible with RC35 and RC37 tops

PRODUCT NO.	FOR
RB00-DDHHL50	RA30 (R Cabinet)
RB01-WWDDHHL50	RA35 (Multi-Drawer Cabinet)
LB00-DDHHL50	LA30 (L Cabinet)

NOTE: Not compatible with RC38 and RC39 tops.

### L100 SMART LOCK



- Intuitive use
- No key required
- Simple and complete management
- Handy unlocking via a transponder or smartphone
- Retrofits on existing Rousseau R or L cabinets with drawers
- Can be used in all configurations of cabinets with drawers
- Compatible with RC35 and RC37 tops

PRODUCT NO.	FOR
RB00-DDHHL100	RA30 (R Cabinet)
RB01-WWDDHHL100	RA35 (Multi-Drawer Cabinet)
LB00-DDHHL100	LA30 (L Cabinet)

NOTE: Not compatible with RC38 and RC39 tops.



The R2V Vertical Storage System is the only product of its type on the market. Stacked above an R cabinet (sold separately), it is ideal for storing more tools and equipment while keeping them within easy reach. By using all vertical space available, you can free up floor space and stay perfectly organized.

The drawers – which are fitted with a lock-in mechanism – open to full extension and boast a load capacity of 200lb. They provide high-density and tidy storage, which helps boost your productivity and efficiency.

- Widths: 24", 30", 36", 42", 48", 54" and 60"
- Depth: 27"
- Heights: 34" and 38"
- Drawer widths: 6", 7", 8", 9", 10", 11" and 12"



## DISTINCTIVE FEATURES

### DRAWER INTERIOR

Pale-gray 071 interior for better visibility



### ERGONOMIC HANDLE

Comfort-grip handle with integrated drawer lock-in mechanism



### ORGANIZATION

Front and rear panels with perforations for hanging tools. Optional utility panels and 5S accessories also available



### LOCKS

Key lock included on all models. Optional electronic locks and two-user lock also available

### 100% EXTENSION

Quick and easy access and identification of tools

HEIGHT COMBINATIONS

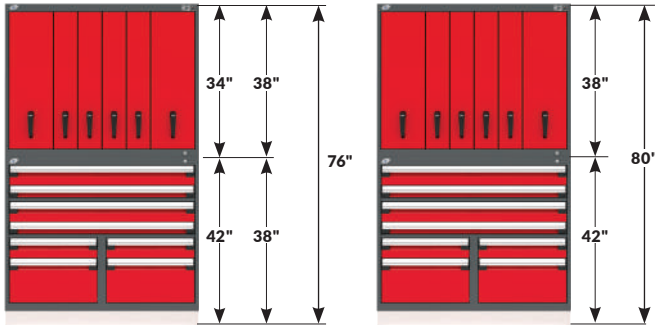

DRAWER SUBDIVISION

To subdivide your drawers, see the layouts and accessories on [pages 59 and 60](#).

OPTIONS UNDERNEATH

TOOLBOXES  
SEE PAGES 44-48

REEL CABINET  
SEE PAGE 63-66

CABINET WITH WASTE AND RECYCLING DRAWER  
SEE PAGE 10

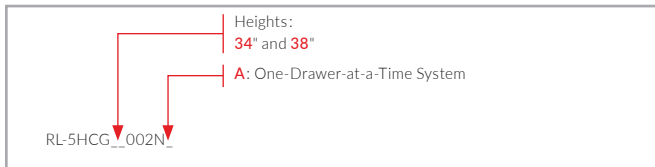

NOTES: The R2V Vertical Storage System must be installed on top of an R cabinet of the same width. It cannot be installed directly on the ground.

For stability reasons, the stacked cabinet must be anchored to the R cabinet underneath.

For compatibility with RD86 / 87 storage unit, contact Customer Service.



There is no mobile version of this product available.

24" W



3 drawers

RL-5HCG\_002N\_



3 drawers

RL-5HCG\_004N\_



2 drawers

RL-5HCG\_006N\_

30" W



3 drawers

RL-5HDG\_002N\_



4 drawers

RL-5HDG\_004N\_



3 drawers

RL-5HDG\_006N\_

36" W



4 drawers

RL-5HEG\_\_002N\_



4 drawers

RL-5HEG\_\_004N\_



3 drawers

RL-5HEG\_\_006N\_

42" W



4 drawers

RL-5HGG\_\_002N\_



5 drawers

RL-5HGG\_\_004N\_



4 drawers

RL-5HGG\_\_006N\_

48" W



6 drawers

RL-5HHG\_\_002N\_



6 drawers

RL-5HHG\_\_004N\_



4 drawers

RL-5HHG\_\_006N\_

54" W



5 drawers  
RL-5HJG\_\_002N\_



6 drawers  
RL-5HJG\_\_004N\_



5 drawers  
RL-5HJG\_\_006N\_



5 drawers  
RL-5HJG\_\_008N\_

60" W



8 drawers  
RL-5HKG\_\_002N\_



6 drawers  
RL-5HKG\_\_004N\_



5 drawers  
RL-5HKG\_\_006N\_



6 drawers  
RL-5HKG\_\_008N\_



You have a project? Our specialists will help you find a customized solution. Contact us.

Choose the interior layout of each drawer using the preconfigured suggestions on this page. Complete your layouts with the accessories on [page 60](#) or [118-121](#) in the 5S section as needed.

- NOTES: 1: Hook perforations on both sides of the panel. Panel position is adjustable across the shelf width.  
 2: Not available for 7"W drawers.  
 3: Available for 10"W drawers and over.  
 4: Panel position is adjustable across the shelf width.

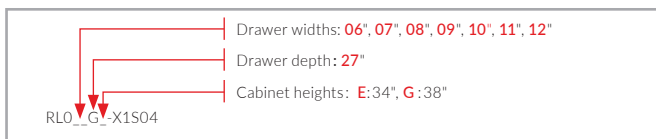



Refer to technical guide R68 for details on accessories compatibility.



Tray, 8 magnetic dividers

RLO\_G-T1001



Adjustable utility panel<sup>1</sup>, 20 hooks

RLO\_G-U0C02



Side utility panel, 20 hooks, plastic bins<sup>2</sup>

RLO\_G-U0S03



2 trays, 12 magnetic dividers

RLO\_G-T2001



Adjustable utility panel<sup>1</sup>, 2 trays, 16 magnetic dividers<sup>3</sup>

RLO\_G-X2C01



Side utility panel, 1 tray, 4 magnetic dividers, plastic bins<sup>2</sup>

RLO\_G-X1S04



RL-XCG76S002NS



RL-XEG76S002NS



RL-XHG76S002NS



RL-XKG76S002NS

### SIDE UTILITY PANEL



- For locating tools quickly and easily
- Full-height and full-depth panel
- Installs on the far right of the drawer but can be easily repositioned on the left
- Color: light gray 071

PRODUCT NO.	CABINET HEIGHT
RL40-2734	34"
RL40-2738	38"

### ADJUSTABLE TRAY



- Ideal for storing assorted products and tools (cans, bottles, etc.)
- Tool-free installation and adjustment
- Includes edges to prevent objects from falling to the bottom of the drawer
- Height adjustable in 1" increments (c/c)
- Compatible with side utility panels. For compatibility with adjustable utility panels, refer to technical guide R68
- Color: light gray 071

PRODUCT NO.
RL21-__27

NOTE: Complete the product number with the drawer width: 06", 07", 08", 09", 10", 11" and 12".

### NON-SLIP DRAWER/TRAY LINER



- Protects tools stored in the drawer or on a tray
- Thick 3/32"

PRODUCT NO.	DEPTH
RL49-__24	24"
RL49-__27	27"

NOTES: Complete the product number with the drawer width: 06", 07", 08", 09", 10", 11" and 12".  
Not compatible with magnetic dividers.

### LABEL HOLDER



- For 7/8"H paper labels
- Label holder height: 15/16"
- Widths available: 6" and 9"

PRODUCT NO.	
RL81-__	Self-adhesive
RL82-__	Magnetic

NOTE: Complete the product number with the desired width: 06", 09".

### ADJUSTABLE UTILITY PANEL



- For locating tools quickly and easily
- Full-height and full-depth panel
- Tools can be hung on each side of the panel without obstructing the drawer
- Width adjustable in 1/2" increments c/c
- Color: light gray 071

PRODUCT NO.	CABINET HEIGHT
RL43-2734	34"
RL43-2738	38"

### MAGNETIC DIVIDER

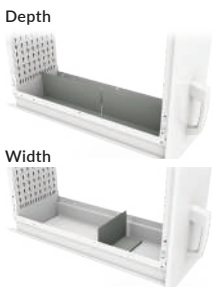

- Installs on drawer bottoms and adjustable trays
- Includes a magnetic strip for easy repositioning
- Divider height: 4"
- Color: light gray 071

PRODUCT NO.	DIVIDER
RL60-2704	Depth
RL61-__04	Width

NOTES: Complete the RL61 number with the drawer width: 06", 07", 08", 09", 10", 11" and 12".  
Not compatible with non-slip drawer/tray liners.

### ONE-DRAWER-AT-A-TIME SYSTEM



- Prevents more than one drawer from opening at the same time for greater stability
- To order: Add "A" to the model numbers on pages 56-58

### L50 DIGITAL LOCK



- Simple, fast and easy to use
- No key required
- Up to 20 different users
- 4- to 8-digit access codes

PRODUCT NO.
RL00-__27L50

NOTE: Complete the product number with the cabinet width: 24", 30", 36", 42", 48", 54" and 60".

### L100 SMART LOCK



- Intuitive use
- No key required
- Simple and complete management
- Handy unlocking via a transponder or smartphone

PRODUCT NO.
RL00-__27L100

NOTE: Complete the product number with the cabinet width: 24", 30", 36", 42", 48", 54" and 60".

# CABINET FOR TWO USERS



Sharing toolboxes between two users is now easy with two-user access. Available for multi-drawer toolboxes and the R2V Vertical Storage System, two-user access allows each technician to lock their own bank of drawers individually. This solution is ideal when two employees share the same workstation and floor space is a challenge. Furthermore, by stacking R2V storage over an R toolbox, you can increase the number of tools stored without using any extra floor space.

- Widths available: 48" and 60"
- Two locks and two distinct locking mechanisms for each housing
- L3 key lock, LP safety hasp, L50 digital lock or L100 smart lock available
- Drawer banks split in two equal parts, from left to right

## SAME WORK SHIFT

Each user has their own workstation while sharing the toolbox (R + R2V)

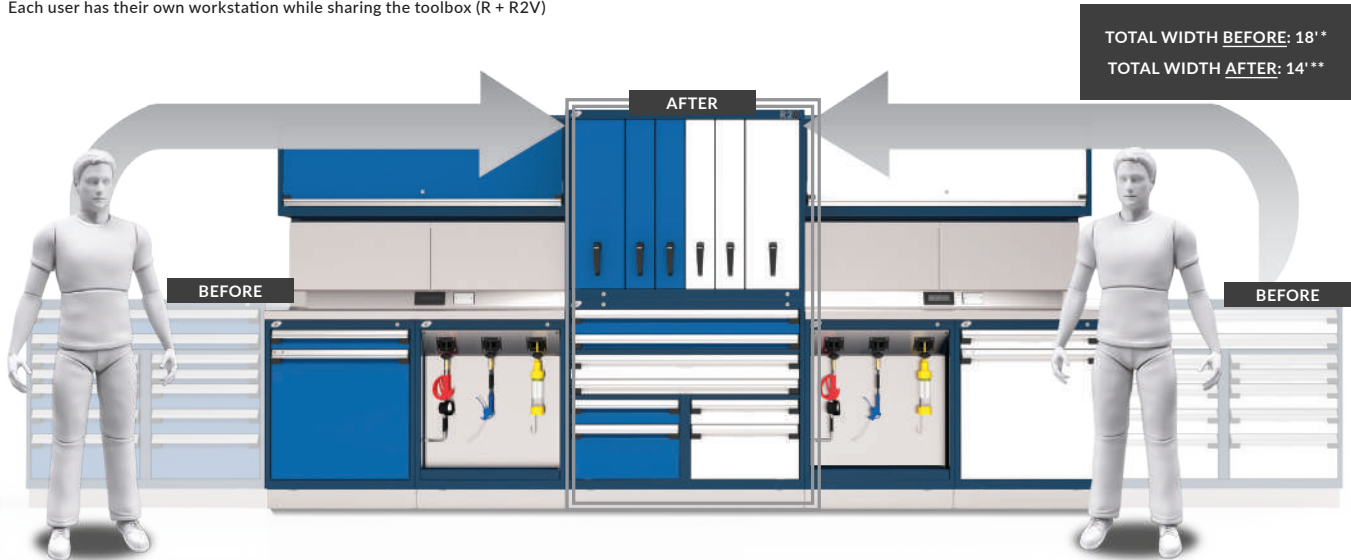

## DIFFERENT WORK SHIFT

Users share the workstation space and the toolbox (R + R2V).

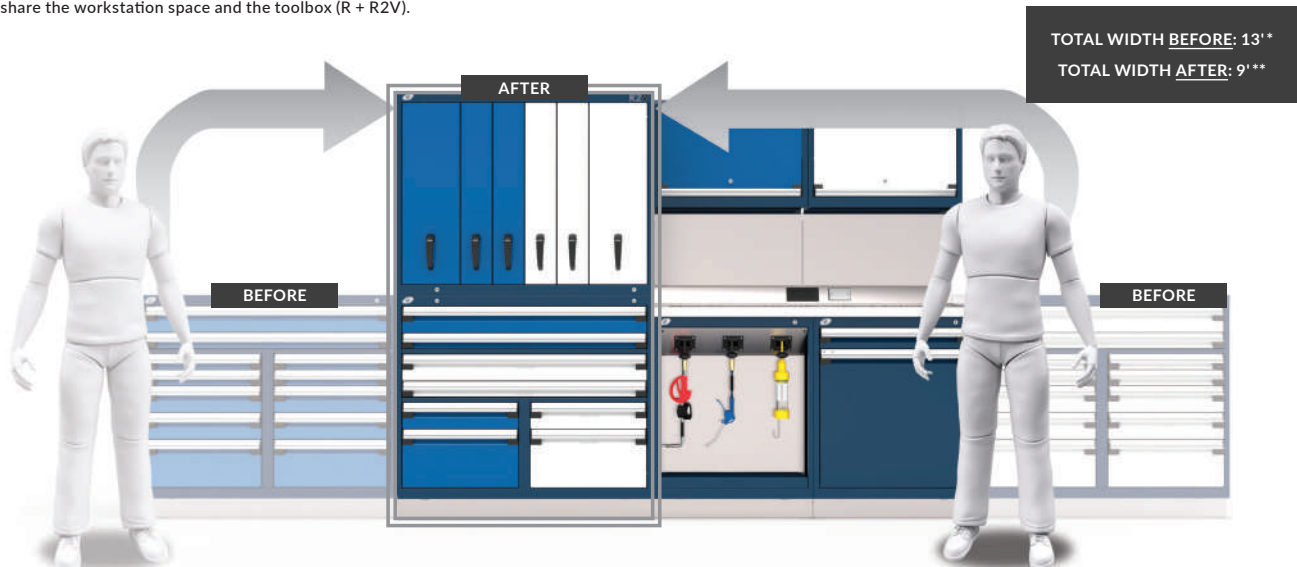

NOTES: \* WITHOUT two-user access \*\* WITH two-user access

Different colors are only shown to help visualize the access and shared space for two different users.

# CABINET FOR TWO USERS

## INDIVIDUAL LOCK FOR USER 1 AND 2



L3 LOCK



L50 DIGITAL LOCK



LP SAFETY LOCK



L100 SMART LOCK

## ONE-DRAWER-AT-A-TIME SYSTEM (OPTIONAL)

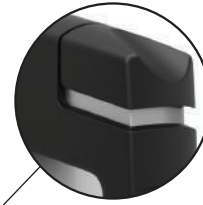
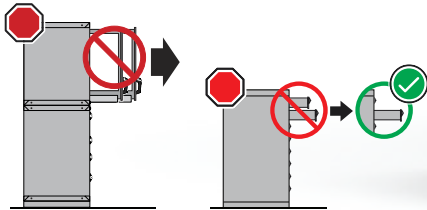

## LOCK-IN MECHANISM

Each vertical drawer includes a mechanism to stop the drawer from opening on its own



## SECURITY PANELS

Blocks access between two banks of drawers



RL91



RF91



RF92

## HERE ARE SOME PRECONFIGURED MODELS



### W×D×H

48"×27"×42"

R6KHG-3802S



### W×D×H

48"×27"×76"

RL-XHG76D002NS



### W×D×H

48"×27"×76"

RL-XHG76D004NS

## FOR CUSTOMIZED MODELS:

### R2V VERTICAL HOUSING



- An RL91 security panel must be ordered to separate the drawers

PRODUCT NO.	W×D
RL29-4827__-L3_	48"×27"
RL29-6027__-L3_	60"×27"

NOTES: Complete the product number with the cabinet height: **34"** or **38"**.

For an digital lock, replace L3 with **L50**.

For a smart lock, replace L3 with **L100**.

For a One-Drawer-at-a-Time mechanism, add **A** to the end of product number.

### MULTI-DRAWER HOUSING



- RF91 and RF92 security panels must be ordered to separate full-width drawers and banks of drawers

PRODUCT NO.	W×D
RA34-4827__-L3_	48"×27"
RA34-6027__-L3_	60"×27"

NOTES: Complete the product number with the cabinet height: **28"**, **30"**, **34"**, **38"**, **44"** or **58"**. The height excludes the 4"H base.

An RA45 partition and RA46 cross tie must be ordered.

For an digital lock, replace L3 with **L50**.

For a smart lock, replace L3 with **L100**.

For a One-Drawer-at-a-Time mechanism, add **A** to the end of product number.

NOTES: Only the housing needs to be ordered for two users; the drawers and other accessories are the same as single-user access.

Two-user access cannot be added to an RA30, RA35 or RL30 cabinet.

For the ideal height combination to reach 76" or 80" high, [see page 56](#).

# SC REEL CABINETS

## DISTINCTIVE SOLUTIONS



Ferrari Maserati Québec (QC)

We know every dealership is unique, which is why we offer a range of reel cabinets that vary according to the number of reels required and where they are placed.

- All our cabinets include a door and/or front panel for easy access and maintenance (optional lock available)
- Removable drip tray included
- Widths: 24", 30", 36" and 48"
- Heights: 30", 38" and 72" (without base)
- 4"H base and quick access panel: painted or stainless steel

## CONSIDERATIONS

Placement of service reels is a very important consideration to achieve the optimal configuration for a technician's workcenter. When reels are to be integrated into the workcenter, we help you determine the best place to store them.

After analyzing technicians' movements between the workcenter and vehicle, we have the following recommendations:

- Place toolboxes near to the technician, under the work surface
- Place reel cabinets in direct line with the automobile, beside the work surface. The reels will therefore not block access to the work surface
- If many different tools are used, we recommend storing the most frequently used tools below the work surface and others in toolboxes at the sides of the work surface

The technician's overall efficiency is increased when there is fast and easy access to tools, and direct and safe access to service reels.

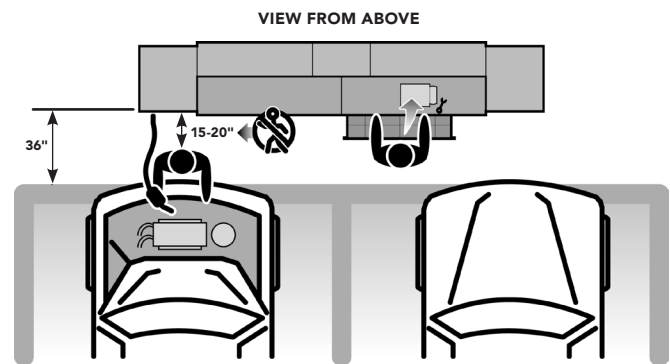

GT-RCG720401S

NOTES: It is your responsibility to check if there are any regulations regarding reel locations in your region.  
Reels are not available from Rousseau.

# 5C REEL CABINETS



GT-REG720601S

Widths available: 24", 30" and 36". The cabinet can store up to six reels.

- Includes a 6"H drawer for meters or other storage and a removable drip tray above the drawer
- Height: 76" (including the 4"H base)
- Can be used in a workcenter or as a standalone unit

GT-RCG720401 \_ 4" base and quick access panel:  
 S: Stainless steel  
 P: Painted steel

NOTE: For a workcenter with a 40"H work surface that includes storage cabinets and finishing panels, we recommend combining the 42"H (including base) reel cabinet with a 38"H toolbox to obtain the same height as the workcenter (80"H).

## 76" H CABINET



24"W - 4 openings

GT-RCG720401 \_



30"W - 4 openings

GT-RDG720401 \_



30"W - 6 openings

GT-RDG720601 \_



36"W - 6 openings

GT-REG720601 \_



GT-C1105P

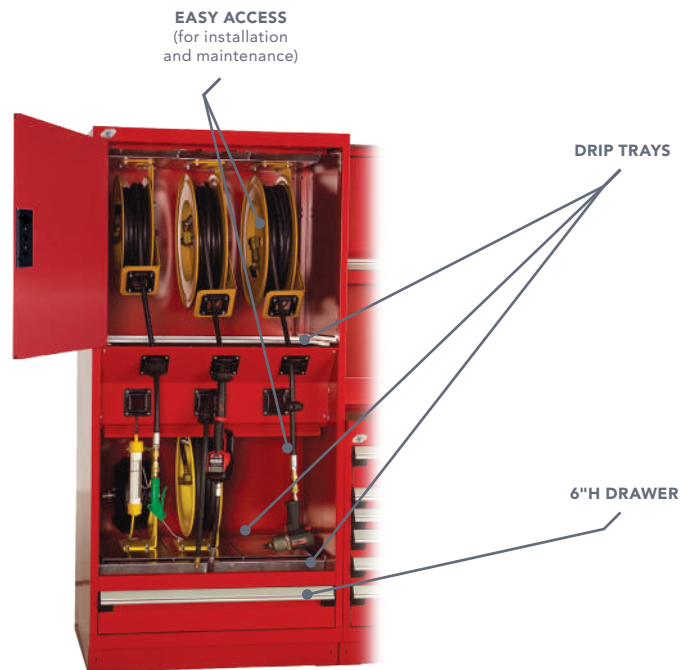



GT-5XEG1001P

Widths available: 24", 30" and 48". The cabinet can store up to six reels.

- The reel cabinet can be stacked on a toolbox (ordered separately). It can also be used in a workcenter or as a standalone unit
- Heights: 38" (without base) and 42" (with base)
- Includes a removable drip tray

Quick access panel:  
**S**: Stainless steel  
**P**: Painted steel

Base:  
**blank**: without base  
**S**: Stainless steel  
**P**: Painted steel

GT-RCG380201 \_\_

---

**NOTE:** For a workcenter with a 40"H work surface that includes storage cabinets and finishing panels, we recommend combining the 42"H (including base) reel cabinet with a 38"H toolbox to obtain the same height as the workcenter (80"H).

38"H AND 42"H CABINETS



24"W - 2 openings

GT-RCG380201 \_\_



30"W - 2 openings

GT-RDG380201 \_\_



30"W - 3 openings

GT-RDG380301 \_\_



36"W - 3 openings

GT-REG380301 \_\_



48"W - 4 openings

GT-RHG380401 \_\_



48"W - 5 openings

GT-RHG380501 \_\_



GT-C1020P



EASY ACCESS  
(for installation  
and maintenance)

DRIP TRAY

# 5C REEL CABINETS



GT-RHG300401P

Widths available: 24", 30" and 48". The cabinet can store up to five reels.

- Installs under the work surface
- Height: 34" (including the 4"H base)
- Includes a removable drip tray

GT-RCG300201 \_

4" base and quick access panel:  
 S: Stainless steel  
 P: Painted steel

## 34" H CABINET



24"W - 2 openings

GT-RCG300201 \_



30"W - 2 openings

GT-RDG300201 \_



30"W - 3 openings

GT-RDG300301 \_



36"W - 3 openings

GT-REG300301 \_



48"W - 4 openings

GT-RHG300401 \_



48"W - 5 openings

GT-RHG300501 \_



GT-C1130S



EASY ACCESS  
(for installation  
and maintenance)

DRIP TRAY

TRUE VERSATILITY AND FUNCTIONALITY



Ferrari Lake Forest (IL)

This is a great solution for your technicians: a unit that can safely store personal belongings as well as an oil barrel, a MultiTek Cart or an L Compact Mobile Cabinet.

- Heights available: 48", 76" and 80".  
Can be used in a workcenter or as a standalone unit
- Two widths available for storage of different items. The 24"W unit can be combined with a MultiTek Cart or L Compact Mobile Cabinet. The 30"W unit can be combined with a MultiTek Cart, oil barrel or L Compact Mobile Cabinet
- Depth: 27"
- An L3 key lock is included with storage units and lockers.  
For an L50 digital lock or an L100 smart lock, please contact Customer Service.
- Leveling glides available, order RA76-03 (pack of 4)

SOME OF OUR MOST POPULAR MODELS ARE SHOWN BELOW:

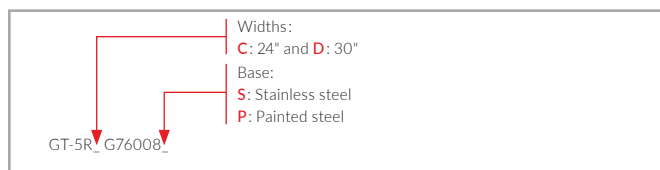

48" H

SLOPED TOP



- Keeps the workspace clean and tidy while reducing clutter
- Fits perfectly into the 5S storage method
- 16° slope angle
- Height: 8"

PRODUCT NO.	W x D
RC31-242708	24" x 27"
RC31-302708	30" x 27"

DOOR EXTENSION



- Compatible with RD86/RD87 storage cabinet doors
- Provides an immaculate finish
- Available in painted or stainless steel

PRODUCT NO.	W x H
RD__-2404	24" x 4"
RD__-3004	30" x 4"

NOTE: Add 81 to the product number for a painted steel extension, or 82 for a stainless steel extension.



Door  
GT-5R\_G48002\_ (Note 1)



Roll-Out Shelf, Door  
GT-5R\_G48004\_ (Note 1)



Door  
GT-5R\_G48002\_ (Note 2)



Clothes Hanging Rail, Door  
GT-5R\_G48001\_ (Note 3)

NOTE #	
1	MultiTek Carts and L Compact Mobile Cabinets must be ordered separately. The photos on pages 67-69 feature the 37"H MultiTek Cart.
2	Oil barrels are not available from Rousseau. They are only compatible with 30"W cabinets.
3	For storage cabinets with clothes hanging rails, the height of the MultiTek Cart is 33". The MultiTek Cart must be ordered separately.



Heavy-duty drawers and roll-out shelves are not compatible with these storage units.  
To ensure unit stability, the unit must be anchored to a workstation, toolbox, storage cabinet or the wall.

76" H



2 Shelves, Clothes Hanging Rail, Door

GT-5R\_G76004\_



2 Shelves, 2 Doors

GT-5R\_G76006\_(Note1)



2 Shelves, Door

GT-5R\_G76007\_(Note 1)



5 Shelves, Door

GT-5R\_G76003\_



Shelf, 2 Doors

GT-5R\_G76002\_(Note 2)



2 Shelves, Clothes Hanging Rail, 2 Doors

GT-5R\_G76008\_(Note 3)



Ferrari Maserati Québec (QC)



Valley Lexus (CA)

76" H



Shelf, 2 Half-Shelves, Half Clothes Hanging Rail, 2 Doors  
GT-5R\_G76014\_ (Note 1)



2 Shelves, 3 Half-Shelves, Half Clothes  
Hanging Rail, Door

GT-5R\_G76009\_



Shelf, 2 Half-Shelves, 2 Half Clothes Hanging Rails, Door  
GT-5R\_G76011\_



2 Shelves, 6 Half-Shelves, Door

GT-5R\_G76010\_



2 Roll-Out Shelves, Door

GT-5R\_G76019\_ (Note 1)



Shelf, 3 Half-Shelves (2 x 12"W, 1 x 18"W), 2 Doors

GT-5R\_G76013\_ (Note 1)



Roll-Out Shelf, Door

GT-5R\_G76020\_ (Note 2)



5 Roll-Out Shelves, Door

GT-5R\_G76021\_



2 Shelves, Clothes Hanging Rail, Door

GT-5R\_G76022\_ (Note 3)

80" H



Shelf, 3 Half-Shelves, 2 Doors  
GT-5X\_G80002\_(Note 1)



3 Shelves, Clothes Hanging Rail, 2 Doors  
GT-5X\_G80004\_



Shelf, 4 Half-Shelves, 2 Doors  
GT-5X\_G80006\_



2 Shelves, 2 Doors  
GT-5X\_G80008\_(Note 2)



Shelf, 2 Half-Shelves, Clothes Hanging Rail,  
Roll-Out Shelf, 2 Doors  
GT-5X\_G80010\_



Shelf, 2 Half-Shelves, 2 Doors  
GT-5X\_G80012\_(Note 2)

NOTE #

- |   |  |
|---|--|
| 1 | MultiTek Carts and L Compact Mobile Cabinets must be ordered separately. The photos on pages 67-69 feature the 37"H MultiTek Cart.     |
| 2 | Oil barrels are not available from Rousseau. They are only compatible with 30"W cabinets.  |
| 3 | For storage cabinets with clothes hanging rails, the height of the MultiTek Cart is 33". The MultiTek Cart must be ordered separately. |



Prémont Harley-Davidson (QC)



Complexe Volkswagen 440 (QC)

Storage units and lockers are an ideal solution for secure storage of technicians' personal belongings or to provide additional storage space for a neat and organized workspace. They also integrate seamlessly with your workstations.

A wide selection of dimensions and options are available to meet your needs:

- Standard widths: 12", 15" and 18" (15"W and 18"W models will store a motorcycle helmet)
- Depth: 27"
- Heights: 48", 76" and 80" (including the 4"H base)
- Includes hanging zones for installing hooks inside the door
- An L3 key lock is included with storage units and lockers. For an L50 digital lock or an L100 smart lock, please contact Customer Service
- Optional accessories include: leveling glides, shelf dividers, hooks and sloped tops

SOME OF OUR MOST POPULAR MODELS ARE SHOWN BELOW:

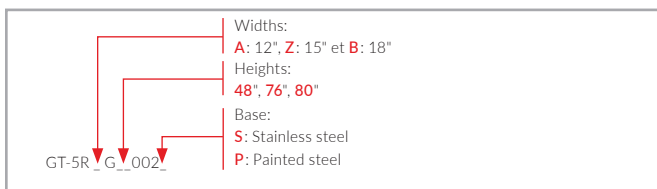

STORAGE CABINETS

DISTINCTIVE FEATURES



48\"H Storage Cabinet,  
2 Adjustable Shelves, Solid Door

GT-5R\_G48001\_



76\"H or 80\"H Storage Cabinet,  
4 Adjustable Shelves, Solid Door

GT-5R\_G\_\_002\_



Heavy-duty  
and ergonomic handle



Vented door  
for lockers



Compatible with  
light-duty hooks



Pale-gray interior for better visibility



Storage cabinets and lockers are sold unassembled.  
To ensure unit stability, the unit must be anchored to a workstation, toolbox, storage cabinet or the wall.

## LOCKERS



48"H Locker, 2 Hooks, Clothes Hanging Rail, Vented Door

GT-5R\_G48003\_



76"H or 80"H Locker, Adjustable Shelf, 2 Hooks, Clothes Hanging Rail, Vented Door

GT-5R\_G\_\_004\_



76"H or 80"H Locker, 4 Hooks, 2 Clothes Hanging Rails, Middle Shelf, 2 Vented Doors

GT-5R \_ G\_\_005\_

## ACCESSORIES

### SLOPED TOP



- Keeps the workspace clean and safe while reducing clutter
- 16° slope angle
- Height: 8"

PRODUCT NO.	W x D
RK90-122708	12" x 27"
RK90-152708	15" x 27"
RK90-182708	18" x 27"

### ADJUSTABLE SHELF



- For storage of equipment
- Height can be adjusted in 1" increments c/c
- Load capacity: up to 100lb.

PRODUCT NO.	W x D
RK93-1227	12" x 27"
RK93-1527	15" x 27"
RK93-1827	18" x 27"

### HOOK



- Attaches under the shelf or top
- Load capacity: 10lb. per hook
- Sold individually

PRODUCT NO.	
RK94-01	1 Hook

### PARTIAL DIVIDER



- Unique concept facilitates position changes
- Height: 5 1/2"
- Easy tool-free installation

PRODUCT NO.
SH52-2406

### LEVELING GLIDES



- Adjusts your storage unit or locker to make it level

PRODUCT NO.	
RA75-01	Pack of 4

### ADJUSTABLE KICK PLATE FOR LEVELING GLIDES



- Provides an immaculate finish
- Prevents dust from entering
- Only available in stainless steel
- Please contact your customer service representative for more details

## A COMPLETE AND INTEGRATED SOLUTION



Honda Queensway (ON)

To perform vehicle repairs and maintenance, technicians need a variety of tools and replacement parts near the vehicle and within easy reach. Every technician has their own way of working, and the requirements of each task can vary considerably between vehicles and between dealerships. The MultiTek Cart's design allows for a high level of personalization based on different work habits and requirements.

- Minimizes trips back and forth
- Transports tools, original parts and spare parts
- Ensures important tools are within easy reach
- Ergonomic working height
- 36"W x 24"D and 48"W x 24"D models are available on [page 114](#) in the Parts Department section

## DISTINCTIVE FEATURES



### LOCKABLE SECURITY COVER

Opens 90° for unrestricted access to the work surface. The cover features strategically placed gas springs to allow access to the top shelf when open. It is also equipped with a lock to secure the contents when closed.



**COMFORTABLE AND ERGONOMIC HANDLES**

### ROLL-OUT SHELF

Expand your work surface area with a roll-out shelf.



### FRONT OR SIDE DRAWERS

Transport tools safely and securely. 4"H drawers feature a lock-in mechanism to keep them closed. 50lb. load capacity per drawer.

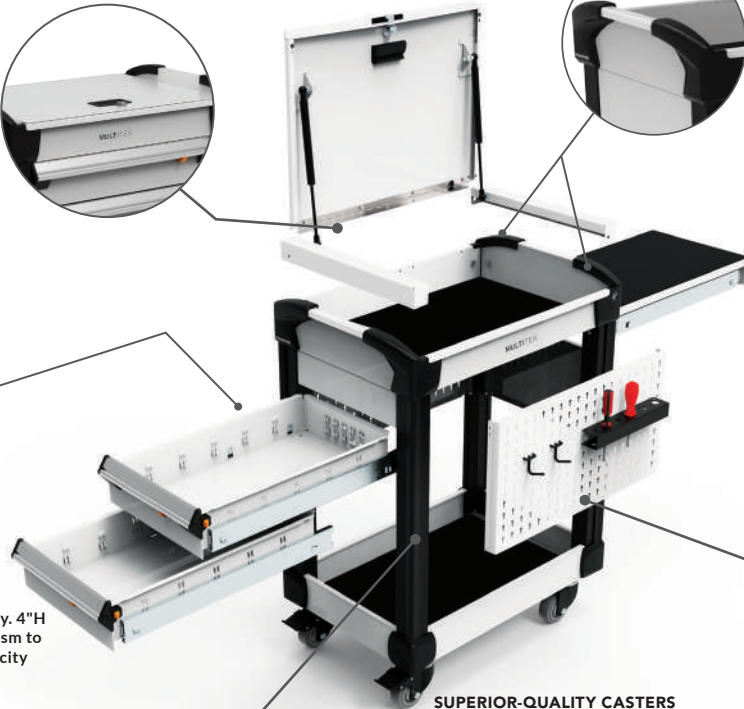

### FINISHING PANELS, UTILITY PANELS OR PLASTIC BIN PANELS

Add accessories to ensure everything you need is always within reach.

### SUPERIOR-QUALITY CASTERS

### UPRIGHT BUMPERS

Protect vehicles from accidental bumps.



Whether you need just one unit or one hundred, our specialists will help you build your ideal configuration.

# MULTITEK CART

## FITS IN STORAGE UNITS AND UNDER WORK SURFACES

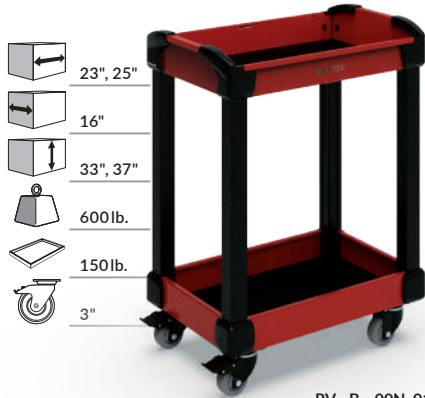

RV-\_B\_\_00N\_01

The 16\"D MultiTek Cart is designed to fit underneath the work surface, behind a hideaway door or inside a side storage unit.

- The 33\"H MultiTek Cart is compatible with a 36\"H workstation; the 37\"H cart is compatible with a 40\"H workstation and a 24\"W or 30\"W storage unit
- For a storage cabinet with clothes hanging rail, the 33\"H MultiTek Cart must be used
- Only the 23\"W version is compatible with RB59/60 and RD81/82 door extensions
- Each shelf can be lined with a rubber mat and has a 150lb. load capacity
- The side roll-out shelf is lined with a rubber mat, has a 15lb. load capacity and provides an extra work surface

	<p>Widths:  <b>D</b>: 23"  <b>G</b>: 25"</p> <p>Heights:  <b>33</b>", <b>37</b>"</p> <p>Rubber mat on each shelf:  <b>0</b>: with  <b>1</b>: without  <b>L3</b>: Drawer lock</p>
--	--

RV-\_B\_\_A1F\_04\_\_B

NOTES: 1: For this model without a rubber mat, replace the letter C with L.  
 2: See page 119 for compatible hooks.



Front drawer

RV-\_B\_\_A1F\_04\_\_B



2 front drawers

RV-\_B\_\_A2F\_04\_\_B



Front drawer, side roll-out shelf



RV-\_B\_\_A1F\_02\_\_B



2 front drawers, side roll-out shelf

RV-\_B\_\_A2F\_02\_\_B



Front drawer, cover, utility panel

RV-\_B\_\_A1UC10\_\_B (Note 1 and 2)



2 front drawers, cover, utility panel, upright bumpers

RV-\_B\_\_A2UC12\_\_B (Note 1 and 2)



# MULTITEK CART



Side drawer



RV\_B\_\_S1F\_04\_\_B



2 side drawers



RV\_B\_\_S2F\_04\_\_B



2 side drawers, side roll-out shelf



RV\_B\_\_S2F\_06\_\_B



2 side drawers, side roll-out shelf,  
cover, utility panels, upright bumpers

RV\_B\_\_S2X\_02\_\_B (Note 2)



Side drawer, side roll-out shelf



RV\_B\_\_S1F\_06\_\_B



Side roll-out shelf



RV\_B\_\_00F\_01

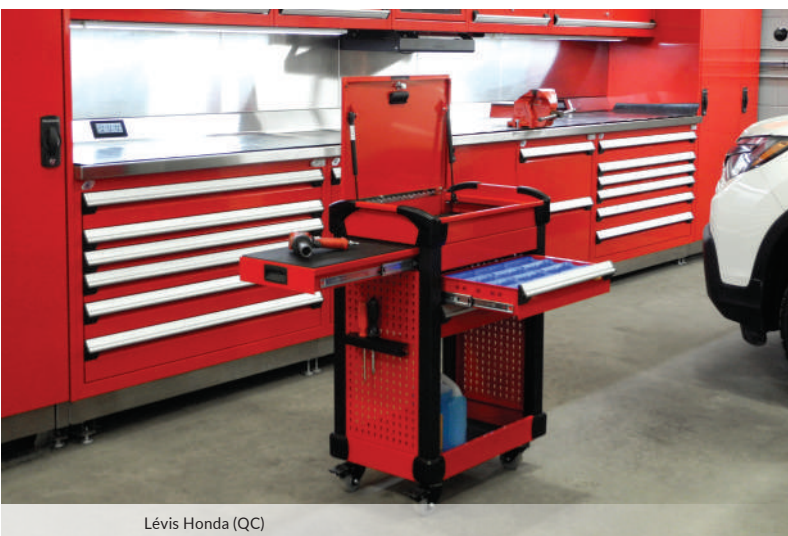

Lévis Honda (QC)



Budds' Imported Cars (ON)

# MULTITEK CART

## INCREDIBLY PRACTICAL AND VERSATILE – NEXT TO THE WORK SURFACE

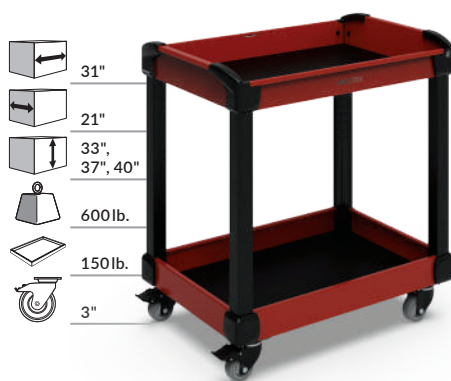

RV-NH\_\_00K\_01 (Note 3)

The 31"W×21"D MultiTek cart is ideal as a freestanding unit. It offers plenty of storage space and multiple configurations. With this size, you can have roll-out half-shelves or half-drawers on both sides of the MultiTek Cart.

- Each shelf can be lined with a rubber mat and has a 150lb. load capacity
- The side roll-out shelf is lined with a rubber mat, has a 15lb. load capacity and provides an extra work surface

Heights:  
33", 37"

Rubber mat on each shelf:  
0: with  
1: without  
L3: Drawer lock

RV-NH\_\_S1F\_04\_\_B

---

NOTES: 1: For this model without a rubber mat, replace the letter C with L.  
2: See pages 119-121 for compatible hooks and plastic bins.  
3: Sold unassembled.



Side drawer

RV-NH\_\_S1F\_04\_\_B



2 side drawers

RV-NH\_\_S2F\_04\_\_B



3 side drawers

RV-NH\_\_S3F\_04\_\_B



3 front drawers, cover, plastic bins panels, upright bumpers

RV-NH\_\_A3X\_02\_\_B (Note 2)



3 front drawers, cover, utility panel, upright bumpers

RV-NH\_\_A3UC16\_\_B (Note 1 and 2)



Side roll-out shelf

RV-NH\_\_00F\_01



Front drawer, 2 side roll-out half-shelves

RV-NH\_\_A1F\_06\_\_B



2 front drawers, 2 side roll-out half-shelves

RV-NH\_\_A2F\_06\_\_B



2 front drawers, 2 side roll-out half-shelves, cover, utility panels

RV-NH\_\_A2UC06\_\_B (Note 1 and 2)



2 side half-drawers

RV-NH\_\_B2F\_02\_\_B



Front drawer, 2 side half-drawers

RV-NH\_\_M3F\_02\_\_B



2 side roll-out half-shelves

RV-NH\_\_00F\_02



3 shelves

RV-NH\_\_00K\_07 (Note 3)



3 shelves, utility panels

RV-NH\_\_00U\_07 (Note 2)



2 front drawers, cover, utility and plastic bin panels

RV-NH\_\_A2X\_08\_\_B (Note 2)

## ACCESSORIES

### NON-SLIP PVC LINER FOR SHELF



- Non-slip PVC protects items stored on shelves
- Thickness: 1/16"

PRODUCT NO.	W x D
RV__-2316-01	23" x 16"
RV__-2516-01	25" x 16"
RV__-3121-01	31" x 21"
RV__-3624-01	36" x 24"
RV__-4824-01	48" x 24"

NOTES: To order a PVC liner for a top or bottom shelf, add **44** to the product number.  
To order a PVC liner for a middle shelf, add **74** to the product number.

### PROTECTIVE FOAM FOR SHELF



- Oil-resistant and non-absorbent foam protects items stored on shelves
- 1/4" blue foam

PRODUCT NO.	W x D
RV__-2316-01	23" x 16"
RV__-2516-01	25" x 16"
RV__-3121-01	31" x 21"
RV__-3624-01	36" x 24"
RV__-4824-01	48" x 24"

NOTES: To order protective foam for a top or bottom shelf, add **46** to the product number.  
To order protective foam for a middle shelf, add **76** to the product number.

### TOOL FOAM FOR SHELF



- Missing tools can be spotted quickly with this oil-resistant and non-absorbent foam on shelves
- The blue foam is 1/4" thick and the black self-adhesive foam is 1/2" thick

PRODUCT NO.	W x D
RV__-2316-01	23" x 16"
RV__-2516-01	25" x 16"
RV__-3121-01	31" x 21"
RV__-3624-01	36" x 24"
RV__-4824-01	48" x 24"

NOTES: To order tool foam for a top or bottom shelf, add **47** to the product number.  
To order tool foam for a middle shelf, add **77** to the product number.  
Sold without cut-outs.

### NON-SLIP PVC LINER FOR DRAWER



- Non-slip PVC protects items stored in drawers
- Thickness: 1/16"

PRODUCT NO.	DRAWER	CART WIDTH
RV49-1623-01S	Side	23"
RV49-1625-01S	Side	25"
RV49-2131-01S	Side	31"
RV49-2131-01S2	Side half	31"
RV49-2316-01F	Front	23"
RV49-2516-01F	Front	25"
RV49-3121-01F	Front	31"

NOTE: Not compatible with partitions and dividers.

### PROTECTIVE FOAM FOR DRAWER

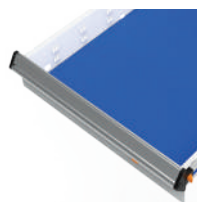

- Oil-resistant and non-absorbent foam protects items stored in drawers
- 1/4" blue foam

PRODUCT NO.	DRAWER	CART WIDTH
RV41-1623-01S	Side	23"
RV41-1625-01S	Side	25"
RV41-2131-01S	Side	31"
RV41-2131-01S2	Side half	31"
RV41-2316-01F	Front	23"
RV41-2516-01F	Front	25"
RV41-3121-01F	Front	31"

### TOOL FOAM FOR DRAWER

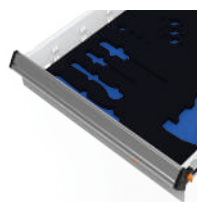

- Missing tools can be spotted quickly with this oil-resistant and non-absorbent foam in drawers
- The blue foam is 1/4" thick and the black self-adhesive foam is 1/2" thick

PRODUCT NO.	DRAWER	CART WIDTH
RV42-1623-01S	Side	23"
RV42-1625-01S	Side	25"
RV42-2131-01S	Side	31"
RV42-2131-01S2	Side half	31"
RV42-2316-01F	Front	23"
RV42-2516-01F	Front	25"
RV42-3121-01F	Front	31"

NOTE: Sold without cut-outs.

### DRAWER LOCK



- Drawer can be locked with the same key used for other products (MultiTek Cart cover, toolboxes, storage cabinets, etc.)
- To order: Add **L3** to the product number

NOTE: 36"W x 24"D and 48"W x 24"D models are available in the parts department section on page 114.

### MIDDLE SHELF



- Load capacity: 150lb. per shelf, 600lb. max. per cart
- One or two shelves can be added to the cart
- Compatible with finishing panels, utility panels and plastic bin panels
- Thickness: 2"

PRODUCT NO.	W × D
RV25-2316	23" × 16"
RV25-2516	25" × 16"
RV25-3121	31" × 21"
RV25-3624	36" × 24"
RV25-4824	48" × 24"

### LONG TOOL HOLDER



- For storing long tools, e.g., pry bars
- Easy to install
- Holds up to three long tools
- Space available for two smaller tools, e.g., screwdrivers

PRODUCT NO.	W × D × H
WM9Q-08	8" × 2" × 4"

### STORAGE UNIT



- A storage unit is perfect for storing MultiTek Carts and L Compact Mobile Cabinets as well as providing enough storage space for personal belongings and other items.
- Available in different heights and configurations, [see pages 67-70](#)
- Optional door extension available
- Accessories available: fixed shelf, roll-out shelf, clothes hanging rail

PRODUCT NO.	TYPE OF BASE
RD86	Painted Steel Base
RD87	Stainless Steel Base

### HIDEAWAY DOOR



- Integrates a MultiTek Cart into the workcenter
- Includes a handle to easily open the door
- Optional door extension available

PRODUCT NO.	W × H	MULTITEK HEIGHT
RB52-1834_ _ _	18" × 34"	33"
RB52-2134_ _ _	21" × 34"	33"
RB52-2434_ _ _	24" × 34"	33"
RB52-2734_ _ _	27" × 34"	33"
RB52-1838_ _ _	18" × 38"	37"
RB52-2138_ _ _	21" × 38"	37"
RB52-2438_ _ _	24" × 38"	37"
RB52-2738_ _ _	27" × 38"	37"

NOTES: Add **L3** to the end of the product number to order a hideaway door with lock.  
Add **L** to the end of the product number to have the hinges on the left or **R** for the hinges on the right.

### UPRIGHT BUMPERS



- Kit of four protective bumpers
- Protects vehicles, surrounding objects and the MultiTek Cart itself
- Made from soft PVC

PRODUCT NO.	MULTITEK CART (W × D)		
	23 × 16	31 × 21	36 × 24
RV63-29	33"H	33"H	35"H
RV63-33	37"H	37"H	39"H
RV63-36		40"H	42"H
RV63-42			48"H

### CASTERS



- Available in two heights: 3" and 5"
- Sold in pairs
- Three types of casters available: fixed, swivel, swivel with brake
- Ultra-quiet casters
- Good chemical resistance to many products found in a vehicle garage (oils, hydrocarbons, water with de-icing salts, antifreeze, lubricants, etc.)

PRODUCT NO.	TYPE	HEIGHT	ACTUAL
RV82-01	Rigid	3"	4¼"
RV82-02	Swivel	3"	4¼"
RV82-03	Swivel with brake	3"	4¼"
RV83-01	Rigid	5"	6"
RV83-02	Swivel	5"	6"
RV83-03	Swivel with brake	5"	6"

NOTES: 23"W × 16"D, 25"W × 16"D and 31"W × 21"D MultiTek Carts include 3" casters by default.  
36"W × 24"D and 48"W × 24"D MultiTek models include 5" wheels by default (see page 114)

# SPECIALIZED UNITS



Budds Jaguar Land Rover (ON)

Bays are often dedicated to specific functions, such as changing tires or express lube.

This means that different accessories may be required to create compact units that are tailored to the task being performed. This section features various suggestions for specialized workspaces.

S: Stainless steel  
P: Painted steel

To complete the product numbers, specify the type of finish for the base, top and power feed panel

e.g.: GT-C1025\_

## OIL CHANGE



### MOBILE EXPRESS LUBE UNIT

- Keeps all the lube equipment you need within easy reach
- 8 sloped shelves with edge for damage-free transportation
- Includes containers for disposing of waste wherever you are

W × D × H	PRODUCT NO.
32" × 27" × 60"	EMA2072



### BASIC OIL CHANGE STATION

- Organized and secure storage for oil change equipment (oil cans, towels, small tools, etc.)
- Power feed panel for constant access to power

W × D × H	PRODUCT NO.
48" × 30" × 36"	GT-C1072_
60" × 30" × 36"	GT-C1075_



### QUICK OIL CHANGE STATION

- Multiple storage compartments for tools and equipment of assorted sizes
- Includes a waste & recycling door to keep the work surface clear and tidy
- Power feed panel for constant access to power

W × D × H	PRODUCT NO.
48" × 30" × 36"	GT-C1073_
60" × 30" × 36"	GT-C1076_



## ILLUMINATED OIL CHANGE STATION

- Complete solution with drawer cabinet, waste & recycling door and top storage cabinet for even more storage
- LED light provides a well-lit work surface
- Power feed panel for constant access to power

W x D x H	PRODUCT NO.
48" x 30" x 76"	GT-C1074_
60" x 30" x 76"	GT-C1077_



## COMPLETE OIL CHANGE STATION

- Reel cabinet with two openings and a removable drip tray for easy cleaning
- Top cabinet for taller items, such as bottles and cans
- Power feed panel for constant access to power
- Drawers of varying heights for flexible storage options

W x D x H	PRODUCT NO.
48" x 30" x 76"	GT-C1025_



## OIL CHANGE STATION WITH COMPUTER CABINET

- Perform oil changes, book appointments and complete your invoicing all at the same workstation
- Reel cabinet with four openings and a removable drip tray for easy cleaning
- The hydraulic hoses are neatly hidden behind a door
- Drawers of varying heights for flexible storage options

W x D x H	PRODUCT NO.
48" x 30" x 76"	GT-C1019_

# SPECIALIZED UNITS

## TIRE CHANGE



### TIRE CHANGE STATION

- This compact workstation installs near tire changer machines to cut down on unnecessary trips back and forth
- Includes many plastic bins for well-organized storage of small parts
- Power feed panel for constant access to power
- Lots of storage for items of different sizes

W×D×H	PRODUCT NO.
36"×30"×76"	GT-C1071_

NOTE: The plastic bin panel is only available in painted steel.

## VEHICLE PREPARATION



### VEHICLE PREPARATION STATION

- Shelf for discreet storage of protective sheets for floor mats while keeping them within easy reach
- Includes a roll holder for car seat protective plastic wrap
- Waste & recycling doors for concealing the containers behind
- Top storage cabinet for keeping finishing equipment within easy reach

W×D×H	PRODUCT NO.
48"×30"×76"	GT-C1078_
60"×30"×76"	GT-C1079_

## WHEEL ALIGNMENT



### ALIGNMENT STATION

- Easily keep an eye on the screen while performing tire tests
- Install wheel alignment tools on the utility panel for quick access
- Power feed panel for constant access to power

W×D×H	PRODUCT NO.
96"×30"×76"	GT-C1170_

## CAR DETAILING



### WALL-MOUNTED CLEANING STATION



- Workspace designed to facilitate car detailing tasks
- Two storage cabinets for storing equipment after use
- Includes shelves to keep cleaning products within easy reach at all times

W × D × H	PRODUCT NO.
60" × 14" × 72"	EMC1000



### WALL-MOUNTED DETAILING STATION

- Ideal for keeping the floor clear while cleaning or to prevent clutter accumulating under the work surface
- All detailing equipment can be stored in the wall-mounted cabinets

W × D	PAINTED STEEL	STAINLESS STEEL
60" × 30"	R5WH5-1010	R5WH5-6010

## HAND WASHING



### SINK STATION

- Provides a sink for technicians to wash their hands when needed
- Extra storage for towels and equipment
- Waste and recycling drawer for keeping the surface clean and tidy at all times

W × D × H	PRODUCT NO.
48" × 30" × 36"	GT-XHG0026S

NOTES : Work surface cutting is not provided by Rousseau.  
Sink not included.



Can't find what you're looking for? Our specialists will help you find a customized solution. Contact us.

# BASIC WORKBENCHES

## A SOLUTION FOR EVERY NEED



Whether you need a basic workbench consisting of two legs and a top, or a more specialized table for mobile or stationary applications, we have a solution for every use case.

Our painted and stainless steel work surfaces are available in a wide range of dimensions, so you can have a single or double workbench tailored to your requirements.

Our solutions also provide unlimited layout possibilities, both above and below the work surface.



### OPEN WORKBENCH – STATIONARY OR MOBILE



- With its sturdy construction and stylish aesthetics, this workbench fits in with almost any environment
- Height: stationary = 34"; mobile = 35"
- To order: Add **A** to the product number for the stationary version and **W** for the mobile version (includes a pair of 4" rigid casters and a pair of 4" swivel casters with total-lock brake system)
- Available with a painted steel or stainless steel top

W×D	PAINTED STEEL	STAINLESS STEEL
60"×30"	<a href="#">WS_1031</a>	WS_6031
72"×30"	WS_1035	WS_6035
72"×36"	WS_1039	WS_6039



### MOBILE WORKBENCH WITH STORAGE UNIT



- The ideal combination of a work surface, storage unit and mobility
- Includes a back edge to prevent your tools and parts from falling
- Available with a painted steel or stainless steel top

W×D×H	PAINTED STEEL	STAINLESS STEEL
60"×30"×39"	<a href="#">LJ1013</a>	LJ6013



### CLOSED WORKBENCH WITH SLIDING DOORS AND CLOSED LEGS

- Provides secure and neat storage of various items with enclosed shelves underneath
- Includes two shelf levels (1 single and 1 double)
- Available with a painted steel or stainless steel top

W×D×H	PAINTED STEEL	STAINLESS STEEL
60"×30"×34"	<a href="#">WSA1170</a>	WSA6170
72"×30"×34"	WSA1171	WSA6171
72"×36"×34"	WSA1172	WSA6172

# BASIC WORKBENCHES

## TEARDOWN BENCH - STATIONARY OR MOBILE



WSA7000

- This workbench has been specially designed to allow liquids to drain cleanly and effectively when repairing transmissions
- The top includes a rim (back and sides) to prevent spills while oil is draining
- The steel surface includes a 2" dia. threaded drain for connecting a drainage pipe
- Stainless steel top

W×D	28"H LEG	32"H LEG	34"H LEG
48"×30"	WS_7000	WS_7010	WS_7020
48"×36"	WS_7001	WS_7011	WS_7021
60"×30"	WS_7002	WS_7012	WS_7022
60"×36"	WS_7003	WS_7013	WS_7023



WSW7000

WS_7000	A: stationary
	W: with 4" casters: 2 rigid and 2 swivel with total-lock brake
	P: with 4" casters: 2 swivel and 2 swivel with total-lock brake



LD75-3201

## DRAWER UNIT WITH 6"H DRAWER

UNIT DEPTH	PRODUCT NO.
21"	LD75-3201__
27"	LD75-4201__

NOTE: Add L3 to the end of the product number to order a drawer lock.



WSC01-01

## DRIP TRAY

PRODUCT NO.	W×D×H
WSC01-01	16"×9"×6"

# BASIC WORKBENCHES

## WORKBENCH WITH L COMPACT CABINET - STATIONARY OR MOBILE



- An L Compact Cabinet is ideal for storing small items and office supplies. With its painted or stainless steel top, this workbench is a great choice as part of a complete storage solution
- Add **G** to the product number for a 21" D cabinet, **H** for a 27" D cabinet and **J** for the mobile version (includes a pair of 4" rigid casters and a pair of 4" swivel casters with total-lock brake)
- Height: stationary = 34"; mobile = 35"
- A range of drawer accessories are also available

W x D	PAINTED STEEL	STAINLESS STEEL
60" x 30"	L_8131L3C	L_7131L3C
72" x 30"	L_8132L3C	L_7132L3C
72" x 36"	LH8133L3C	LH7133L3C

## OPEN DOUBLE WORKBENCH



- With its sturdy construction and stylish aesthetics, this workbench fits in with almost any environment.
- It can be adapted to your requirements by simply adding accessories
- Includes one shelf level
- Available with a painted steel or stainless steel top

W x D x H	PAINTED STEEL	STAINLESS STEEL
96" x 30" x 34"	WSA1902	WSA6902
120" x 30" x 34"	WSA1904	WSA6904
144" x 30" x 34"	WSA1906	WSA6906

## WORKBENCH WITH SLIDING DOORS



- Provides secure and neat storage of various items
- Two toolboxes: 2 x 60" W with two integrated sliding doors
- Includes two shelf levels
- Available with a painted steel or stainless steel top

W x D x H	PAINTED STEEL	STAINLESS STEEL
120" x 30" x 34"	R5XWG-3002	R5XWG-3004



# SERVICE ADVISOR DESKS

WELCOMING - PROFESSIONAL - MODERN



Oxford Dodge Chrysler (ON)

Rousseau's service advisor desks create a dedicated space for greeting customers. As well as its welcoming and contemporary looks, it has been designed to facilitate all tasks performed by a service advisor.

This includes initial greeting, delivery of keys, explanation of work to be performed, work order planning, car preparation and payment. For all this and more, the service advisor desk excels and impresses both visitors and advisors.

- Spacious work surface including a cable grommet to keep the surface clear
- Work surface and riser shelf have rounded fronts for a distinctive and welcoming look
- Choice of models with or without cabinet (18"W x 27"D x 38"H) to meet the advisor's needs
- Work surface and riser shelf options: stainless steel, gray laminate and wood
- No visible cables
- Sold assembled



## LAYOUT OPTIONS

Choose one or more stationary or mobile desks to meet the needs of your dealership. You can join stationary desks together in either a side-by-side or offset configuration. With a wide range of accessories available, you can build a truly personalized service advisor desk.

### MOBILE



### STATIONARY (SINGLE)



### SIDE BY SIDE



### OFFSET



# SERVICE ADVISOR DESKS

METICULOUSLY DESIGNED TO PROVIDE AN ORGANIZED WORKSPACE

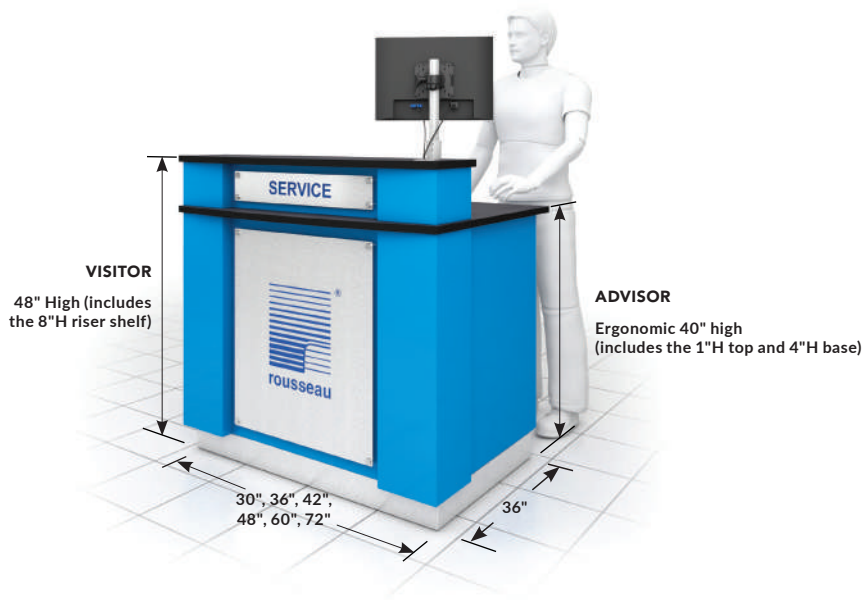

**OPTIONS**  
Panel with or without personalization

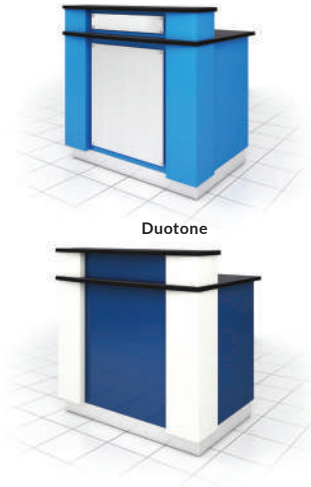

## DESKTOP:

- monitor mount
- Multiple top and riser shelf options

## UNDER THE WORK SURFACE:

- Fixed shelf
- Waste and recycling containers
- Printer shelf
- Adjustable shelf
- Door with lock to secure personal belongings

## UNDER THE RISER SHELF:

- Power outlets and USB ports
- LED light

## WITH OR WITHOUT CABINET:

- Multiple drawer heights available
- 12"H drawer for file storage
- The drawer has a 100lb. load capacity and the total load capacity of the cabinet is 250lb.

**STATIONARY AND MOBILE VERSIONS AVAILABLE**

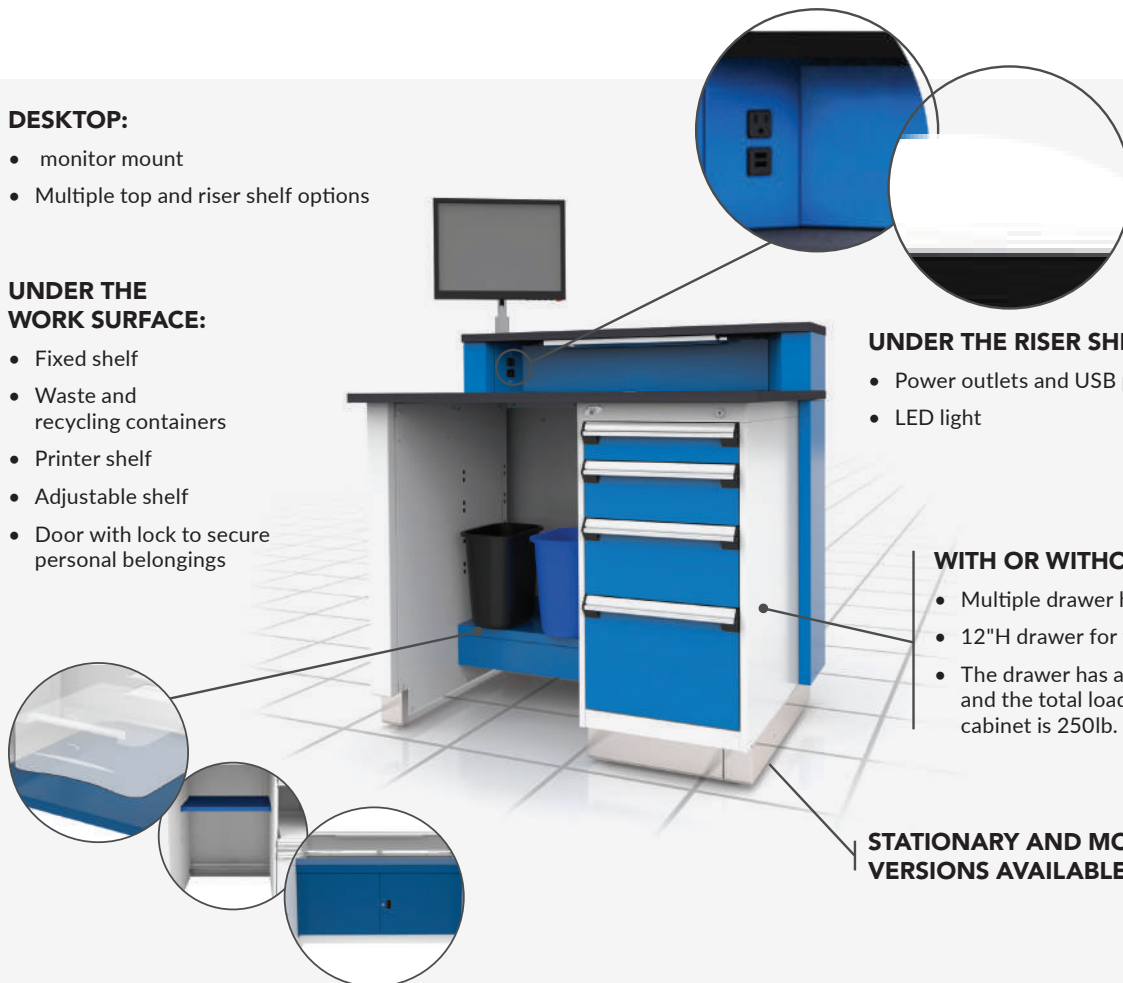

NOTE: To add accessories to preconfigured models, please contact Customer Service.

# SERVICE ADVISOR DESKS

## BUILD YOUR OWN

Follow the steps below to order your own customized service advisor desk. By choosing the various options available, you can build a desk that fulfills your requirements and matches your brand image. You can choose the top, finishing panels, and six different widths for both mobile and stationary desks.

**1** B: Mobile  
D: Stationary

**2** Widths:  
D: 30", E: 36", G: 42", H: 48", K: 60", L: 72"

**3** Top:  
5: Laminate, O: Stainless Steel, 2: Wood

**4** Panel:  
S: Stainless Steel, P: Painted Steel

RP-    J38\_0020    

---

Complete the model number on pages 90-92 with the options below.

### 1 TOPS



#### MOBILE (B)

- Includes 2" casters for moving the desk easily when required
- Four casters are included for desks with two legs
- Six casters are included for models with one leg and a cabinet

NOTE: Side-by-side desks and offset desks cannot be mobile.



#### STATIONARY (D)

- The stainless steel bases include leveling glides for easy leveling
- Includes four leveling glides, except the 60"W and 72"W versions with cabinet, which include five
- Side-by-side and offset configurations are possible by adding desk joining kit RP-K001S

### 2 WIDTHS

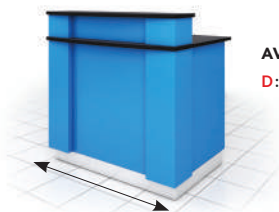

#### AVAILABLE WIDTHS:

D: 30", E: 36", G: 42", H: 48", K: 60", L: 72"

### 3 TOPS

Tops and riser shelves have rounded corners (visitor side).

#### STAINLESS STEEL (O)



#### GRAY LAMINATE (5)



#### WOOD (2)



### 4 PANEL CHOICE AND COLORS

#### NO PANEL



NOTE: No code to add. Base models come without a panel.

#### WITH PAINTED (P) OR STAINLESS (S) STEEL PANEL



With this option, you can personalize your desk by adding a logo or name, see page 94.

NOTE: Not available for the 30"W version.

#### FOR DUOTONE



Simply specify your chosen colors when ordering. There is no code to add.

### 5 ACCESSORIES

See page 93

To join two or more service advisor desks together, side by side or offset, please order desk joining kit RP-K001S, see page 92.

NOTE: Side-by-side desks and offset desks cannot be mobile.

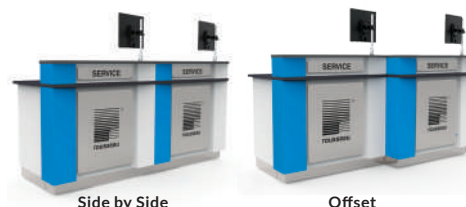

# SERVICE ADVISOR DESKS

## FRONT VIEW FOR PRECONFIGURED MODELS

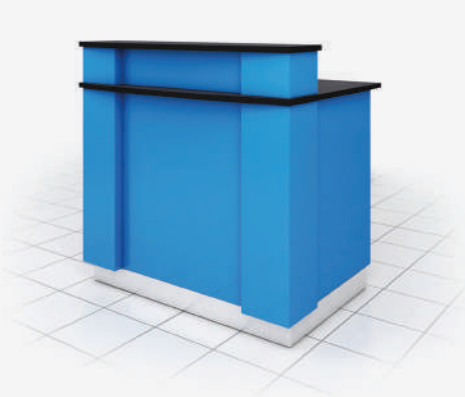

**1** B: Mobile  
 D: Stationary  
**2** Widths:  
 D: 30", E: 36", G: 42", H: 48", K: 60", L: 72"  
**3** Top:  
 5: Laminate, O: Stainless Steel, 2: Wood  
**4** Panel:  
 S: Stainless Steel, P: Painted Steel

RP-\_\_J38\_0020S\_

Complete the model number on pages 90-92 with the options below.

### NOTE #

1	Only available for 42, 48"W, 60"W and 72"W desks.
2	The shelf width varies according to the desk width. 24"W for a 48"W desk; 36"W for a 60"W desk; 48"W for a 72"W desk.
3	48"W desk = 24"W double doors; 60"W desk = 36"W double doors; 72"W desk = 48"W double doors.
4	Available in 30"W only.
5	Desks with doors cannot be mobile.

## REAR VIEW

### BASIC DESK



- Riser shelf

PRODUCT NO.

RP-\_\_J38\_0020S\_

### BASIC DESK WITH MONITOR MOUNT



- Riser shelf with 1 power outlet and 2 USB ports
- monitor mount
- LED light
- Full-width shelf
- Waste and recycling containers

PRODUCT NO.

RP-\_\_J38\_0040S\_

### DESK WITH CABINET



- Riser shelf
- 18"W cabinet with 4 drawers

PRODUCT NO.

RP-\_\_J38\_002RS\_ (Note 1)

### DESK WITH CABINET AND MONITOR MOUNT



- Riser shelf with 1 power outlet and 2 USB ports
- monitor mount
- LED light
- 18"W cabinet with 4 drawers
- Shelf
- Waste and recycling containers

PRODUCT NO.

RP-\_\_J38\_004RS\_ (Note 1 and 2)

# SERVICE ADVISOR DESKS

## DESK WITH CABINET



- Riser shelf
- 18"W cabinet with 2 drawers and 1 roll-out shelf

**PRODUCT NO.**  
RP-\_J38\_006RS\_ (Note 1)

## DESK WITH CABINET AND MONITOR MOUNT



- Riser shelf with 1 power outlet and 2 USB ports
- monitor mount
- LED light
- 18"W cabinet with 2 drawers and 1 roll-out shelf
- Shelf
- Waste and recycling containers

**PRODUCT NO.**  
RP-\_J38\_008RS\_ (Note 1 and 2)

## DESK WITH CABINET, MONITOR MOUNT AND SECURE STORAGE UNDER THE WORK SURFACE

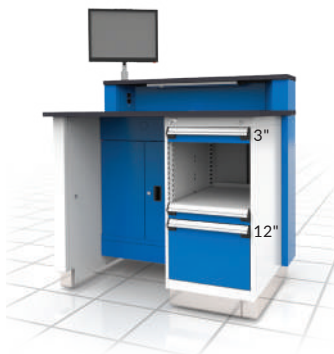

- Riser shelf with 1 power outlet and 2 USB ports
- monitor mount
- LED light
- 18"W cabinet with 2 drawers and 1 roll-out shelf
- Adjustable shelf
- Shelf
- Door with lock to secure personal belongings

**PRODUCT NO.**  
RP-D\_J38\_012RS\_ (Note 1, 2, 3 and 5)

## DESK WITH CABINET AND SECURE STORAGE UNDER THE WORK SURFACE



- Riser shelf with 1 power outlet and 2 USB ports
- LED light
- 18"W cabinet with 4 drawers
- Adjustable shelf
- Shelf
- Door with lock to secure personal belongings

**PRODUCT NO.**  
RP-D\_J38\_010RS\_ (Note 1, 2, 3 and 5)

## DESK WITH PRINTER SHELF



- Riser shelf with 1 power outlet and 2 USB ports
- Power feed panel under the work surface
- Printer shelf
- LED light

**PRODUCT NO.**  
RP-\_DJ38\_0060S (Note 4)



Grimsby Ford (ON)

# SERVICE ADVISOR DESKS

## DOUBLE SERVICE ADVISOR DESKS



### DESKS WITH CABINETS AND MONITOR MOUNTS

- Gray laminate tops
- 2 shelves (24"W)
- 2 riser shelves with 1 power outlet and 2 USB ports each
- Waste and recycling containers
- 2 monitor mounts
- Stainless steel finishing panels
- 2 LED lights
- 2 cabinets (18"W) with 4 drawers each

PRODUCT NO.	WIDTH
RP-C252004SS	96"

NOTE: This model number is effectively 2 × model RP-DHJ385004RS on [page 90](#), plus desk joining kit RP-K001S.



### DESK WITH CABINET AND MONITOR MOUNT COMBINED WITH DESK WITH PRINTER SHELF

- Wood tops
- 2 riser shelves with 1 power outlet and 2 USB ports each
- monitor mount
- 2 LED lights
- 18"W cabinet with 4 drawers
- 24"W shelf
- Waste and recycling containers
- Printer shelf
- Power feed panel under the work surface
- Stainless steel finishing panels

PRODUCT NO.	WIDTH
RP-C221002SS	78"

NOTE: This model number is effectively model RP-DHJ382004RSS and RP-DDJ3820060S on [pages 90-91](#), plus desk joining kit RP-K001S.

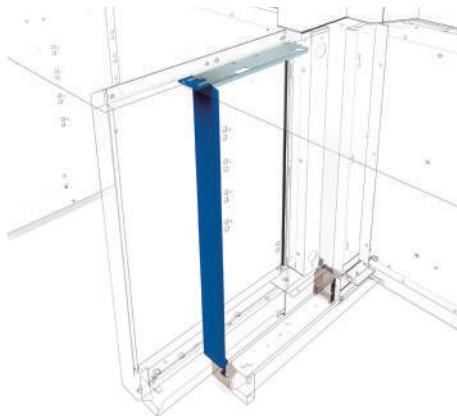

### DESK JOINING KIT

- For joining two or more stationary service advisor desks together
- Suitable for side-by-side (linear) and offset configurations
- In offset configurations, the offset distance between desks is 8"
- One kit required per additional desk
- Includes finishing strips and attachment bars

PRODUCT NO.
RP-K001S

NOTE: Side-by-side desks and offset desks cannot be mobile.

# SERVICE ADVISOR DESKS

## ACCESSORIES



**WASTE AND RECYCLING CONTAINERS**

<b>PRODUCT NO.</b>	
RP46-01	Recycling Container
RP46-02	Waste Container



**DOOR WITH LOCK TO SECURE PERSONAL BELONGINGS**

<b>PRODUCT NO.</b>
RP48



**ADJUSTABLE SHELF**

<b>PRODUCT NO.</b>
RP41



**PRINTER SHELF**

<b>PRODUCT NO.</b>
RP43-2121

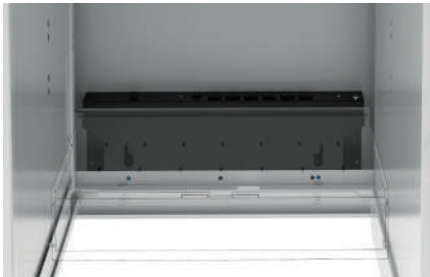

**POWER FEED PANEL UNDER THE WORK SURFACE**

<b>PRODUCT NO.</b>
RP95

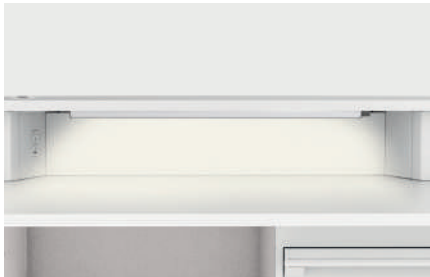

**LED LIGHT**

<b>PRODUCT NO.</b>
RP89



**PHONE AND NETWORK CABLE KIT**

<b>PRODUCT NO.</b>
RP95-01



**CABLE MANAGEMENT KIT**

<b>PRODUCT NO.</b>
RP95-02



**10 ADHESIVES CABLE TIES MOUNTING KIT**

<b>PRODUCT NO.</b>
RP95-03

NOTE: To add accessories to preconfigured models, please contact Customer Service.

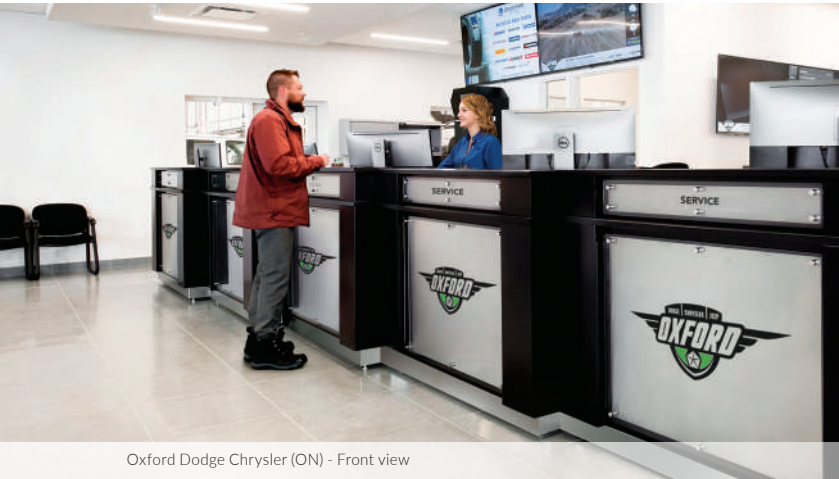

Oxford Dodge Chrysler (ON) - Front view

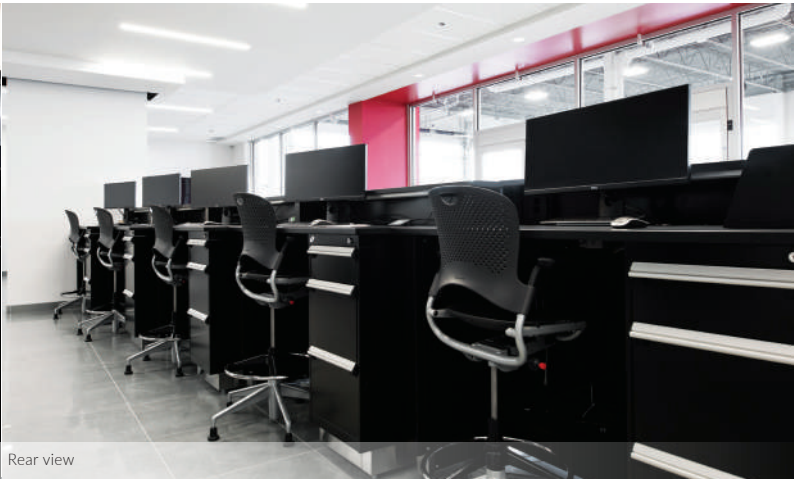

Rear view

# PERSONALIZED PANELS

STAND OUT FROM THE COMPETITION!



Oxford Dodge Chrysler (ON)

Rousseau offers a personalization service for painted or stainless steel panels installed on GT workstations, service advisor desks and corner service counters.

Panels can be personalized with a logo, a name or even a slogan. Personalization is performed using digital printing with UV ink. It is a highly durable process that creates an immaculate finish and is easy to clean.

- Endless color possibilities
- For maximum impact, the design is always centered (vertically and horizontally)
- Existing panels can be replaced with new personalized panels

## SEVERAL OPTIONS AVAILABLE



Digital printing with UV ink



Mirror finish to simulate a chrome finish

AVAILABLE FOR:

### GT WORKSTATIONS



Order:  
Stainless: RC42 + RZ99-43  
Painted: RC41 + RZ99-43

### CORNER WORKSTATIONS



Order:  
Stainless: RS83 + RZ99-43  
Painted: RS87 + RZ99-43

### SERVICE ADVISOR DESKS



Order:  
Stainless: RP96 + RZ99-43  
Painted: RP99 + RZ99-43

### SERVICE COUNTERS



Order:  
Stainless: RS96 + RZ99-43  
Painted: RS99 + RZ99-43