

SIGNAGE

FLOOR MARKING

TICKETS & LABELLING

RACKSACK®

SHADOW BOARDS

DOCUMENT DISPLAY

IMPACT PROTECTION

SHELVING & STORAGE



Edition 33

EST. 1984

BEAVERSWOOD®

making the workplace work smarter



Visual Management Solutions



About Us

We are Beaverswood®

We make the workplace work smarter with our range of visual management products, suitable for lean manufacturing and 5S - or any workplace that needs to be safe, productive, and in order.

Simple Products, Big Results

The beauty of our products is their quality and simplicity - simple to install and simple to use - ensuring you get the best performance from day one.

Our Story

Since 1984 Beaverswood® has been involved in the design, manufacture and development of alpha-numeric labelling systems for quick and easy identification of products and locations. Beginning humbly in a small bedroom - with just one product - our self-adhesive numbers and letters.

Quality Assurance Policy

Meeting and exceeding the high standards expected of our customers calls for a systematic and disciplined approach by all employees to the principles of Quality Assurance. That's why we have an established Quality Management System based on the requirements of BS EN ISO 9001:2015.



UKWA Membership

We are a member of the UKWA - the leading trade organisation for the warehousing sector.



We are part of IWS Group

A family of specialist industrial product owners, manufacturers and service companies, each of which are market-leaders in their niche.

Collectively, the group's range of products and solutions cover workplace safety; impact protection; racking safety solutions and protection; storage; recycling; 5S and visual communications.



Installation Service

Our fully trained in-house team of labelling installers offer a professional, high-quality service throughout the UK. [See more info on page 28.](#)

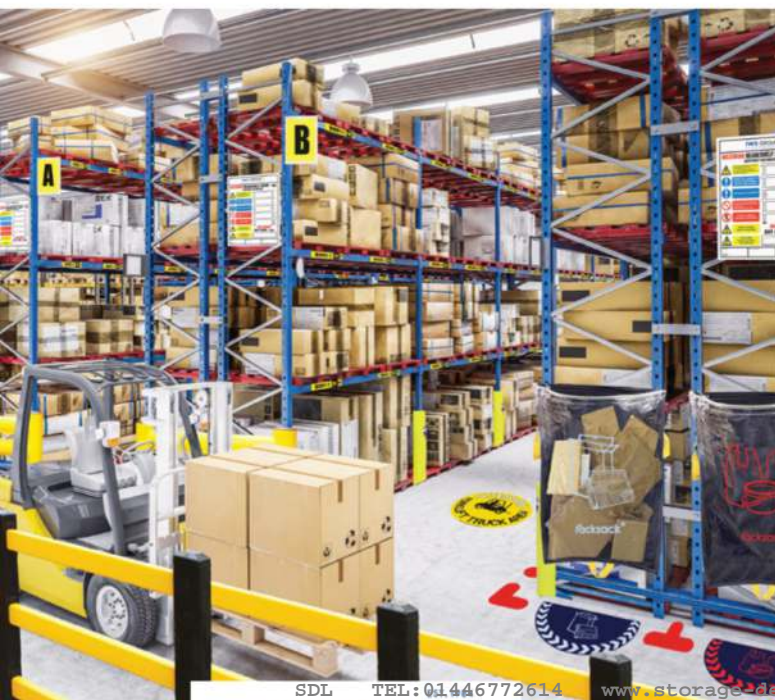

Product Demonstration Videos



Head over to our YouTube channel to watch all of our product demonstration videos.



www.youtube.com/user/BeaverswoodSupply

Catalogue Categories

Pages 8 - 39

Tickets & Labelling

Premium quality tickets and labelling for organising your racking, shelving, and storage locations.



Pages 40 - 47

Signs

Clearly identify racking and pallet locations, highlight hazards and provide crucial rack-loading information.



Pages 48 - 61

Floor Marking

Floor signs and markers with multiple purposes, from highlighting warnings to marking storage locations.



Pages 62 - 77

Document Display

A range of document frames and holders to display important messages within the workplace.



Pages 78 - 83

Shadow Boards

Modulean® - a range of modular standard boards that aid in compliance with the 5S lean system.



Pages 84 - 95

Impact Protection

Brandsafe® - products that are intelligently designed to protect your workspace and improve human resource safety.



Pages 96 - 105

Shelving & Storage

Anco® - a range of robust and versatile storage solutions from packing workstations to plastic storage bins and more.



Pages 106 - 118

racksack®

The original waste segregation solution, simplifying a complicated and laborious process to separate waste.



Where To Find...

- Adhesive Backed Pockets 73
- Aisle Markers 42 - 43
- Angled Aisle Markers 42
- Angled Ticket Holders 9
- Anti-slip Feet 61
- Anti-slip Stair Treads 61
- Anti-slip Tapes 60
- Armco Accessories 85
- Bay Markers 41
- Bespoke Floor Markers 49
- Bollards 93
- Clicka Shelving 101
- Clear Document Pockets 63 - 65
- Column Protectors 86 - 87
- Component Organisers 100
- Consecutive Number Tiles 37
- Electric Vehicle Charging Kits 90
- Electric Vehicle Charging Stencils 90
- Flexi Delineators 88
- Floor Level Barriers 93
- Floor Signals 50 - 51
- Floor Graphic Markers 54 - 55
- Floor Identification Markers 58
- Floor Marking Tape 59
- frames4docs® 74 - 77
- frames4floors® 52 - 53
- Half Circle Floor Graphic Markers 56 - 57
- Hanging Pockets 69
- Hold-All® Ring Binders 70 - 71
- Identification Tiles 37
- Information Labels 47
- Label Holders 14 - 17
- Lamp and Sign Post Protectors 89
- Lane Marking Applicator 59
- Location Labelling 28 - 31
- Low Level Bumper Barriers 91
- Mag-grip 26 - 27
- Magnetic Location Markers 22
- Magnetic Easy-wipe Racking Strip 18 - 19
- Magnetic Label Holders 16 - 17
- Magnetic Numbers and Letters 36
- Magnetic Self-adhesive Strip 20 - 21
- Magnetic Ticket Holders 12 - 13
- Magnetic Wrap-around Pockets 68
- Modulean® Lite 79
- Modulean® Rack End Boards 82 - 83
- Modulean® Shadow Boards 80 - 81
- Numbers and Letters 32 - 36
- Packing Workstation 102 - 103
- Pallet Marker 38
- Pedestrian Barriers 92
- Pedestrian Bumper Barriers 92
- Plastic Storage Bins 104
- Projection Markers 42
- Rack Armour® Upright Protection 94 - 95
- Rack End Barriers 91
- racksack® 107 - 110
- racksack® clear 111
- racksack® mini 112 - 113
- racksack® nano 114 - 115
- racksack® rollcage 116 - 117
- racksack® trolley 118
- Rainbow Pockets 66 - 67
- Rivet Racking 98
- Rivet Racking Bays with Bins 99
- Self-adhesive Label Holders 14
- Self-adhesive Magnetic Clip 26 - 27
- Self-adhesive Numbers and Letters 32 - 35
- Self-adhesive Ticket Holders 10 - 11
- Shelving Aisle Marker 43
- Shelf Trays on Racks 97
- Speed Bumps 88
- Stock Identity Slider 39
- Stock Indicator Wheel 38
- Ticket Holders 9 - 13
- Ticket Pouches 24 - 25
- Wall Louvre Kits 105
- Weather Resistant Pockets 72
- Weight Load Identification 44 - 46
- Wheel Stops 89
- Wire Shelving Clip Holders 23

Page No.

Our Brands

Each of our product brands has its own history and personality, but they all have one thing in common – making the workplace work smarter!



racksack® is the original waste segregation solution. Instead of a standard industrial floor bin, racksack® hangs from end-of-aisle racking. The clever design ensures it doesn't encroach on valuable floor space even when full, helping you utilise your warehouse space more effectively.



frames4docs® are a unique range of colour-coded frames designed for easy and prominent document display. Perfect for use in offices, shops, libraries and throughout the workplace to display all types of literature, certificates and information.



Modulean® has taken away the need (and the headache) for custom shadow boards, by creating a genius range of standard boards that are widely used across the workplace, removing a great deal of expense and time that's associated with purchasing shadow boards.



A range of coloured document pockets, perfect for 5S and lean management systems. They're available in 5 colours to transform plain notices into eye-catching displays.



Hold-All® ring binders for walls are ideal for keeping those important documents not just clean and tidy but also all in one place, helping to create a central information point.



Rack Armour®'s innovative design and functionality has revolutionised racking protection and provides a proven 80% reduction in damage levels – saving time, money and hassle.



Bespoke Solutions

As a manufacturer, we excel at bespoke solutions. In fact, 40 – 60% of all products we supply are bespoke requests, tailored to meet the unique needs of customers.

Whether we're designing and producing products from scratch or modifying existing products to suit specific requirements – we're ready to tackle the challenge!



Get in touch by phone on
0118 979 6096
 or email us at
sales@beaverswood.co.uk



YOUR COMPANY DETAILS HERE

MAXIMUM BEAM/SHELF LOADS - kgs
(UNIFORMLY DISTRIBUTED)

- Consult regular inspections to check for:
 - correct application and use
 - loads within allocated safe limits
 - structural damage or disengagement of structure components
- REPORT ALL DAMAGE TO PERSON RESPONSIBLE FOR SITE MANAGEMENT
- REPORT ALL ACCIDENTS
- Do not alter the structure without either:
 - obtaining written approval from our technical staff
 - written approval from supplier
- DO NOT CLIMB ON SHELVING OR RACKING
- REFER TO SEMA CODE OF PRACTICE
- IF IN DOUBT ALWAYS CONTACT THE SUPPLIER

MAXIMUM BAY LOAD - kgs

JOB REF: _____ DATE SUPPLIED: _____ NOTES: _____
 CONTACT TEL. NO: _____

THIS NOTICE SHOULD NOT BE REMOVED

Become a Reseller



We're dedicated to helping our resellers succeed by providing superior products, specialist support, and best-in-class service.

Many of our resellers have been in business with us for over 20 years. We're proud of that. When we ask them why, they tell us it's because we're responsive, knowledgeable, and our service levels are outstanding.

Beaverswood® has been making the workplace work smarter since 1984. We manufacture innovative products that improve the efficiency, safety, and sustainability of the physical workplace. The beauty of our products is their quality and simplicity – simple to install and simple to use. This makes their features easy for your sales team to understand and demonstrate, while your customers can easily see the benefits they'll bring to their workplace.

Now, with over 35 years' experience and over 2,000 SKUs across 30 product groups, we continually strive to innovate simplified solutions.

Our product range includes: warehouse ID, tickets and labelling, magnetic tapes, floor marking, document display, shadow boards, racksack® waste segregation, storage and impact protection.

Some of our current Resellers



All you need. With love.



CROMWELL

KAISER+KRAFT

RAJAPACK
N°1 IN EUROPE FOR PACKAGING

SSETON
Signs, Labels & Solutions for a Safer Workplace

BRADY
WHEN PERFORMANCE MATTERS MOST

Slingsby
Your workplace partner

arco
Experts in Safety

OT GROUP
PART OF PARAGON GROUP

integra
Business Solutions Limited

nemo
the power of independence

nectere
your business, our support

superstat.

officefriendly

35+



years' experience in warehouse identification solutions and more



60,000

square foot warehouse and production facilities

2,000+

SKUS across



30

different product categories

Unbeatable service and support

26



year average length of relationship with our top 10 customers

Global reach with a local feel



50%

of total sales are to continental Europe



Quality management system EN ISO 9001:2015 - we continually improve our products and services

Reasons to Partner with Beaverswood®

Increase revenue



for your business

Benefit from a



discounted reseller rate

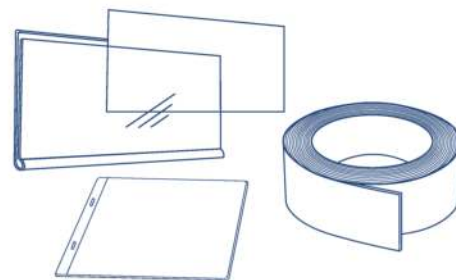

Our products are relevant to a wide variety of sectors



Reseller toolkit with product images, videos, spec sheets and more

Bespoke



flyers and brochures

Sample packs



Reseller virtual warehouse



You sell it, we ship it



We drop-ship on your behalf

Sales team product training



We are a manufacturer with bespoke product development capabilities



In-depth e-commerce audits to maximise your sales opportunities

We're part of **IWS GROUP**
the Industrial Workspace Specialists
grow with us!

Get in touch to become a Beaverswood Reseller by phoning us on 0118 979 6096, emailing us at sales@beaverswood.co.uk or visit our website www.beaverswood.co.uk



Tickets & Labelling

Organise your racking, shelving, and storage locations with Beaverswood® premium quality tickets and labelling solutions. These products are simple to install (thanks to self-adhesive and magnetic fixings) and deliver reusability and scannability to keep your operations running smoothly.

Although perfect for warehousing, our labels suit many other workplaces that require clear identification systems, such as offices, shops, schools, retail, packaging, factories, and 5S and lean manufacturing environments.



Angled Ticket Holders

- ➔ Provides the perfect angle to read information and scan barcodes, even on the lowest shelves
- ➔ Strong adhesive tape strip, perfect for fixed locations
- ➔ Ideal for warehouses, retail, supermarkets, etc.
- ➔ Available in two angled options: 106° and 126°



Self-adhesive



This ticket holder hangs at an angle from the shelf to ensure optimum visibility, allowing operatives or customers to get a clear view of the information within.

Manufactured from clear PVC, barcodes are easy to scan through this holder without removing the insert. Additionally, the strong adhesive backing is perfect for permanent locations.

Supplied with blank white card inserts (pre-printed inserts can also be supplied – please get in touch!)

ATHS220

ATHS320



Angled Ticket Holders

Ref	Angle	Size (h x w)	Pack
ATHS210	106°	26mm x 100mm	100
ATHS220	106°	26mm x 200mm	50
ATHS310	126°	39mm x 100mm	100
ATHS320	126°	39mm x 200mm	50

➔ For non-standard lengths please contact our sales office.

Self-adhesive Ticket Holders



- ➔ Ideal for fixed locations but inserts offer the ability to change data
- ➔ Pull forward front allows easy loading and updates of information
- ➔ Industrial, heavy duty strength
- ➔ Barcodes can be scanned without removing the insert
- ➔ Pre-cut sizes from stock

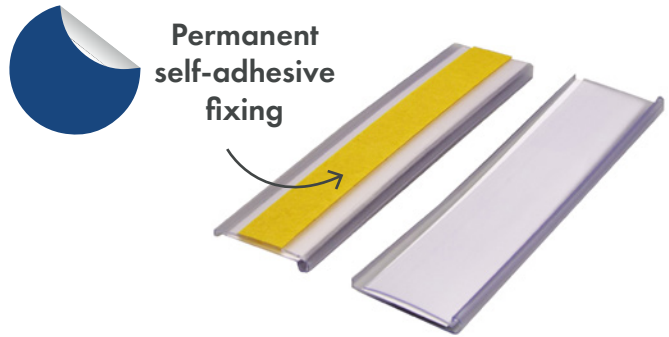

With a choice of 5 heights and up to 3M lengths, this clear PVC strip is supplied with an aggressive adhesive backing for permanent locations. Simply remove the yellow strip and stick into position.

Special sizes are available upon request, with lengths up to 3M. If you need any help choosing a size, please contact the sales office for more information.

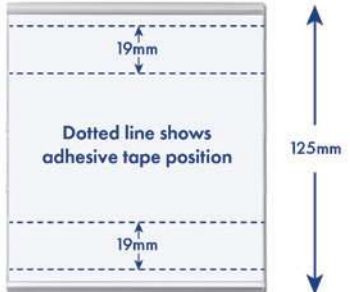
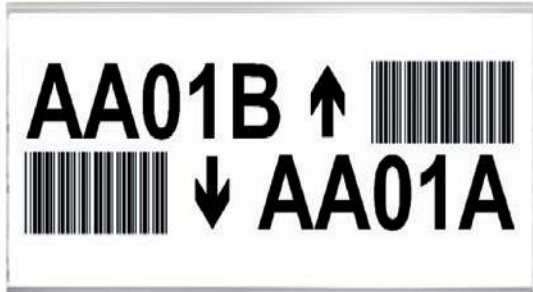

Ticket Holder profiles size showing tape position on reverse
Height in mm

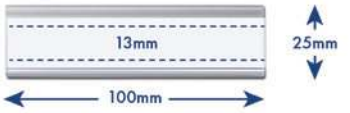
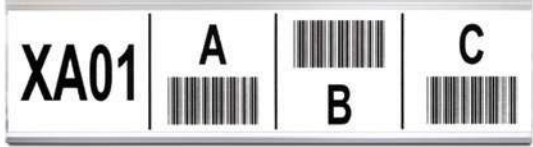

Can be used on all sealed surfaces

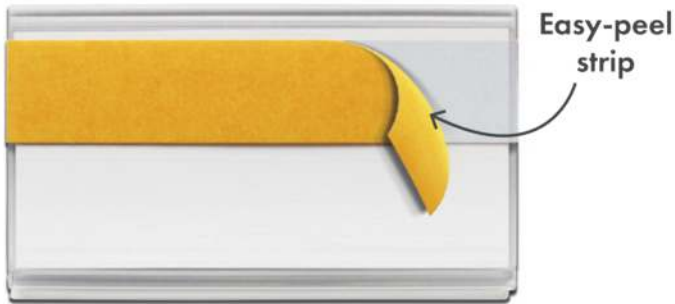
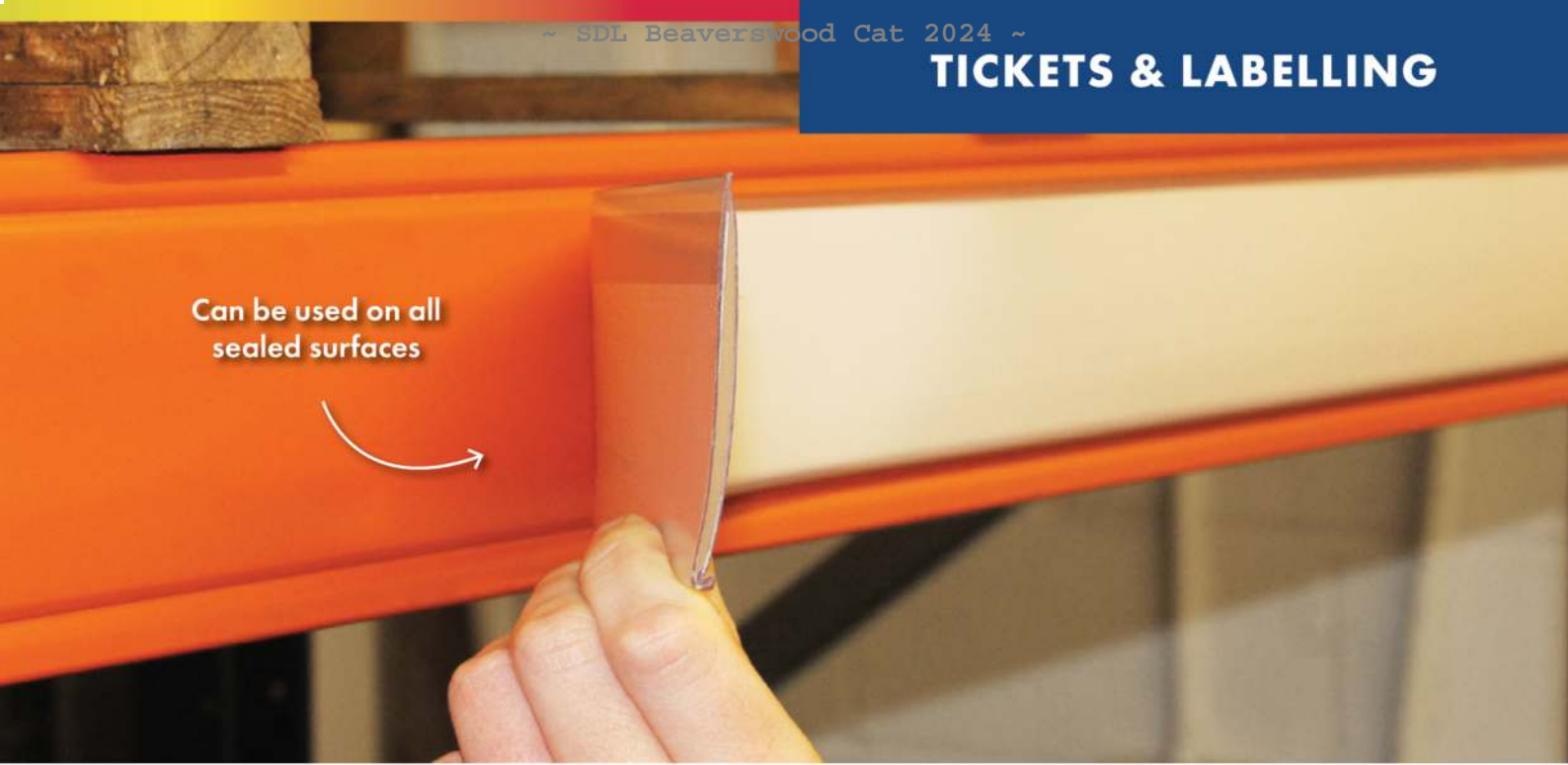

Self-adhesive Ticket Holders

Ref	Size (h x w)	Pack	Card Insert
TS210	25mm x 100mm	100	✓
TS220	25mm x 200mm	50	✓
TS25/10	25mm x 1M	10	✓
TS25/20	25mm x 2M	10	
TS25/60	25mm x 2M	30	
TS25/100	25mm x 2M	50	
TS25/250	25mm x 2M	125	
TS310	38mm x 100mm	100	✓
TS320	38mm x 200mm	50	✓
TS38/10	38mm x 1M	10	✓
TS38/20	38mm x 2M	10	
TS38/60	38mm x 2M	30	
TS38/100	38mm x 2M	50	
TS38/250	38mm x 2M	125	
TS510	54mm x 100mm	100	✓
TS520	54mm x 200mm	50	✓
TS54/10	54mm x 1M	10	✓
TS54/20	54mm x 2M	10	
TS54/60	54mm x 2M	30	
TS54/100	54mm x 2M	50	
TS54/250	54mm x 2M	125	
TS810	80mm x 100mm	100	✓
TS820	80mm x 200mm	50	✓
TS80/10	80mm x 1M	10	✓
TS80/20	80mm x 2M	10	
TS80/60	80mm x 2M	30	
TS80/100	80mm x 2M	50	
TS80/250	80mm x 2M	125	
TS125/200	125mm x 200mm	50	✓
TS125/10	125mm x 1M	10	✓



Would you like printing or label installation with that?



Printed Inserts

Don't run the risk of picking errors caused by unclear identification. We can also print and install labelling that will give you a clear and highly visible identification system.

See [page 28](#) for more details.

- ➔ For non-standard widths please contact our sales office.
- ➔ Supplied in lengths of up to 3M.
- ➔ Sizes over 1.2M will incur extra carriage charges.

Magnetic Ticket Holders

- ➔ Ideal for identifying locations on shelving and pallet racking
- ➔ Barcodes can be scanned without removing the insert
- ➔ Ideal for cold stores and chillers
- ➔ Pre-cut sizes from stock
- ➔ Special sizes upon request (up to 3M lengths)

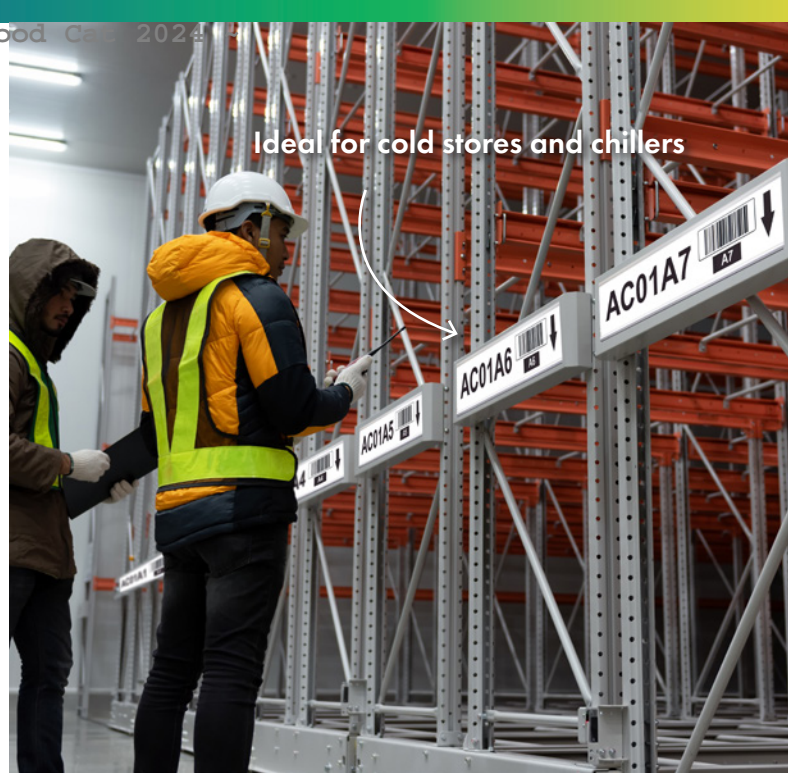

Ideal for cold stores and chillers

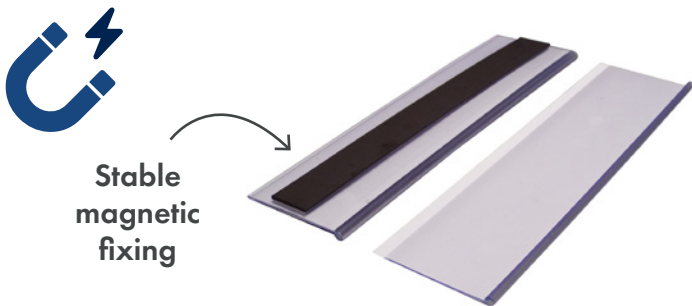

Available in a choice of 5 heights, this clear PVC strip is supplied as a magnetic option which offers the flexibility to change locations and is ideal for cold storage applications.

Special sizes are available upon request, with lengths up to 3M. Sizes over 1.2M will incur extra carriage charges. If you need any help choosing a size, please contact the sales office for more information.

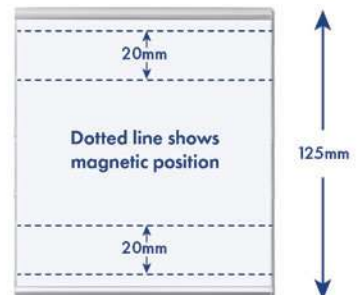
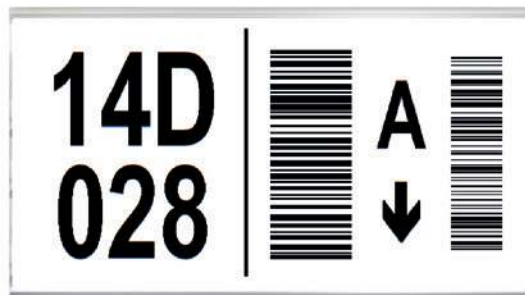

Ticket Holder profiles size showing tape position on reverse
Height in mm

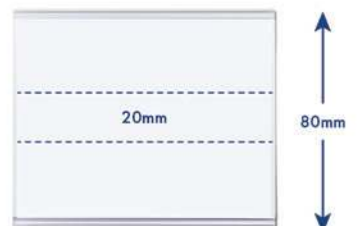



Extra large ticket holder, ideal for fitting on heavy duty beams

Position of magnetic strips can be changed to suit non flat beams



Magnetic strip on reverse



Easily update inserts

Would you like printing or label installation with that?



Printed Inserts

Don't run the risk of picking errors caused by unclear identification. We can also print and install labelling that will give you a clear and highly visible identification system.

See [page 28](#) for more details.

Magnetic Ticket Holders

Ref	Size (h x w)	Pack	Card Insert
TS210M	25mm x 100mm	100	✓
TS220M	25mm x 200mm	50	✓
TS25M/10	25mm x 1M	10	✓
TS25M/20	25mm x 2M	10	✓
TS310M	38mm x 100mm	100	✓
TS320M	38mm x 200mm	50	✓
TS38M/10	38mm x 1M	10	✓
TS38M/20	38mm x 2M	10	✓
TS510M	54mm x 100mm	100	✓
TS520M	54mm x 200mm	50	✓
TS54M/10	54mm x 1M	10	✓
TS54M/20	54mm x 2M	10	✓
TS810M	80mm x 100mm	100	✓
TS820M	80mm x 200mm	50	✓
TS80M/10	80mm x 1M	10	✓
TS80M/20	80mm x 2M	10	✓
TS125M/200	125mm x 200mm	50	✓
TS125M/10	125mm x 1M	10	✓

Additional White Card Inserts

Ref	Size (h x w)	Pack
TC210	25mm x 100mm	100
TC220	25mm x 200mm	50
TC250	25mm x 1M	10
TC310	38mm x 100mm	100
TC320	38mm x 200mm	50
TC350	38mm x 1M	10
TC510	54mm x 100mm	100
TC520	54mm x 200mm	50
TC550	54mm x 1M	10
TC810	80mm x 100mm	100
TC820	80mm x 200mm	50
TC850	80mm x 1M	10
TC125/200	125mm x 200mm	50
TC125/10	125mm x 1M	10

Self-adhesive Label Holders

Self-adhesive



- ➔ Instant and highly visible identification
- ➔ Long term fixing
- ➔ Standard sizes supplied from stock
- ➔ Ideal for pigeon holes and shelving

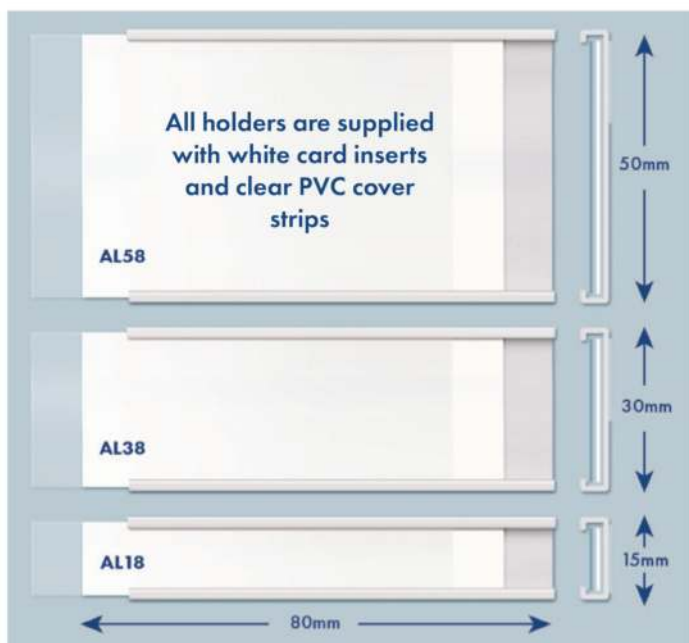

Our self-adhesive label holders are supplied with a strong adhesive to offer a long-term fixing option, providing extra stability in environments where the inserts need to be changed frequently.

The smaller holders are ideal for the identification of pigeon holes and also suit narrow edge shelving used in schools, libraries, and offices.

Self-adhesive Label Holders

Ref	Size (h x w)	Pack
AL18	15mm x 80mm	100
AL38	30mm x 80mm	100
AL58	50mm x 80mm	100
AL1/10	15mm x 1M	10
AL3/10	30mm x 1M	10
AL5/10	50mm x 1M	10

➔ For non-standard lengths please contact our sales office.

Card Inserts

Additional card and PVC inserts are available for the label holders.

Please specify whether it is to be used with the self-adhesive or magnetic holders.

See [page 15](#) for [PVC information](#).

Ref	Description	To suit holder size (h x w)	Pack	Ref	Description	To suit holder size (h x w)	Pack
LC18	Card Insert	15mm x 80mm	100	LC820	Card Insert	80mm x 200mm	50
LC28X	Card Insert	20mm x 80mm	100	LC150	Card Insert	15mm x 500mm	20
LC28	Card Insert	25mm x 80mm	100	LC250X	Card Insert	20mm x 500mm	20
LC38	Card Insert	30mm x 80mm	100	LC250	Card Insert	25mm x 500mm	20
LC48	Card Insert	40mm x 80mm	100	LC350	Card Insert	30mm x 500mm	20
LC58	Card Insert	50mm x 80mm	100	LC450	Card Insert	40mm x 500mm	20
LC610	Card Insert	60mm x 100mm	100	LC550	Card Insert	50mm x 500mm	20
LC620	Card Insert	60mm x 200mm	50	LC650	Card Insert	60mm x 500mm	20
LC710	Card Insert	70mm x 100mm	100	LC750	Card Insert	70mm x 500mm	20
LC720	Card Insert	70mm x 200mm	50	LC850	Card Insert	80mm x 500mm	20

Magnetic Label Holders Cut Pieces



- ➔ Instant and highly visible identification
- ➔ Easy to update and relocate
- ➔ Suitable for use in cold temperatures
- ➔ Standard sizes are available from stock, in 9 heights and 3 lengths
- ➔ Other lengths can be supplied upon request



Our magnetic label holders are supplied in pre-cut lengths from stock, however special lengths can be supplied upon request. These rubberised magnetic C profile holders are ideal for applications where regular changes are required. Suitable for use in cold stores and chillers.

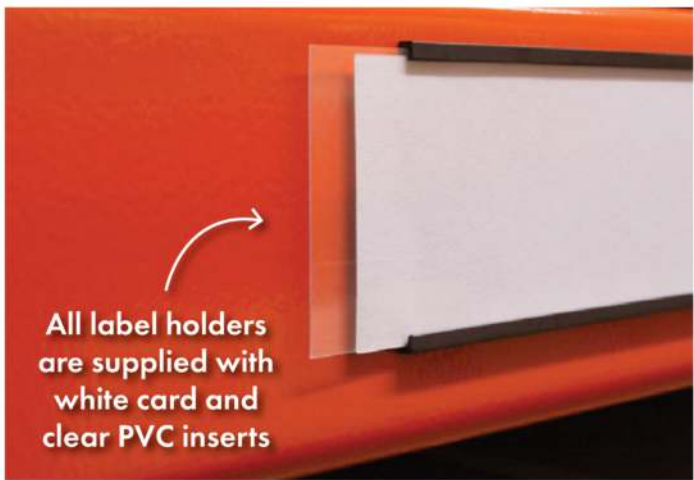

Magnetic Label Holders

Ref	Size (h x w)	Pack
ML18	15mm x 80mm	100
ML28X	20mm x 80mm	100
ML28	25mm x 80mm	100
ML38	30mm x 80mm	100
ML48	40mm x 80mm	100
ML58	50mm x 80mm	100
ML610	60mm x 100mm	100
ML620	60mm x 200mm	50
ML710	70mm x 100mm	100
ML720	70mm x 200mm	50
ML820	80mm x 200mm	50

PVC Inserts

Additional clear PVC inserts are available for the label holders.

Please specify whether it is to be used with the self-adhesive or magnetic holders.

See [page 14](#) for [card inserts](#).

Ref	Description	To suit holder size (h x w)	Pack
LP18	PVC Insert	15mm x 80mm	100
LP28X	PVC Insert	20mm x 80mm	100
LP28	PVC Insert	25mm x 80mm	100
LP38	PVC Insert	30mm x 80mm	100
LP48	PVC Insert	40mm x 80mm	100
LP58	PVC Insert	50mm x 80mm	100
LP610	PVC Insert	60mm x 100mm	100
LP620	PVC Insert	60mm x 200mm	50
LP710	PVC Insert	70mm x 100mm	100
LP720	PVC Insert	70mm x 200mm	50

Ref	Description	To suit holder size (h x w)	Pack
LP820	PVC Insert	80mm x 200mm	50
LP150	PVC Insert	15mm x 500mm	20
LP250X	PVC Insert	20mm x 500mm	20
LP250	PVC Insert	25mm x 500mm	20
LP350	PVC Insert	30mm x 500mm	20
LP450	PVC Insert	40mm x 500mm	20
LP550	PVC Insert	50mm x 500mm	20
LP650	PVC Insert	60mm x 500mm	20
LP750	PVC Insert	70mm x 500mm	20
LP850	PVC Insert	80mm x 500mm	20

Magnetic Label Holders

Longer Lengths



Perfect for 1 metre wide shelving

- ➔ Instant and highly visible identification
- ➔ Easy to cut to required size
- ➔ 500mm and 1M wide cut lengths
- ➔ All supplied from stock
- ➔ Other lengths can be supplied
- ➔ Supplied complete with white card inserts and PVC cover strips

These magnetic holders are ideal to affix across the full width of the shelf. They're quicker and easier to use in situations where lots of labels are required, and can be cut to size with scissors if needed.

Magnetic Label Holders - Shelf Width

Ref	Size (h x w)	Pack
ML150	15mm x 500mm	20
ML250X	20mm x 500mm	20
ML250	25mm x 500mm	20
ML350	30mm x 500mm	20
ML450	40mm x 500mm	20
ML550	50mm x 500mm	20
ML650	60mm x 500mm	20
ML750	70mm x 500mm	20
ML850	80mm x 500mm	20
ML1/10	15mm x 1M	10
ML2X/10	20mm x 1M	10
ML2/10	25mm x 1M	10
ML3/10	30mm x 1M	10
ML4/10	40mm x 1M	10
ML5/10	50mm x 1M	10
ML6/10	60mm x 1M	10
ML7/10	70mm x 1M	10
ML8/10	80mm x 1M	10

➔ *Non-standard lengths are our speciality, please contact our sales office for a personalised quotation.*

Label Holder profiles size
Height in mm

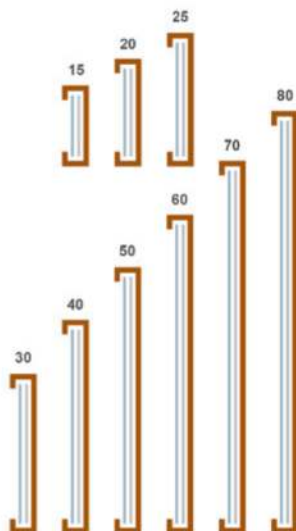

Card Inserts

Additional card and PVC inserts are available for the label holders.

Please specify whether it is to be used with the self-adhesive or magnetic holders.

See [page 17](#) for [PVC information](#).

Ref	Description	To suit holder size (h x w)	Pack	Ref	Description	To suit holder size (h x w)	Pack
LC18	Card Insert	15mm x 80mm	100	LC820	Card Insert	80mm x 200mm	50
LC28X	Card Insert	20mm x 80mm	100	LC150	Card Insert	15mm x 500mm	20
LC28	Card Insert	25mm x 80mm	100	LC250X	Card Insert	20mm x 500mm	20
LC38	Card Insert	30mm x 80mm	100	LC250	Card Insert	25mm x 500mm	20
LC48	Card Insert	40mm x 80mm	100	LC350	Card Insert	30mm x 500mm	20
LC58	Card Insert	50mm x 80mm	100	LC450	Card Insert	40mm x 500mm	20
LC610	Card Insert	60mm x 100mm	100	LC550	Card Insert	50mm x 500mm	20
LC620	Card Insert	60mm x 200mm	50	LC650	Card Insert	60mm x 500mm	20
LC710	Card Insert	70mm x 100mm	100	LC750	Card Insert	70mm x 500mm	20
LC720	Card Insert	70mm x 200mm	50	LC850	Card Insert	80mm x 500mm	20

Magnetic Label Holders Rolls

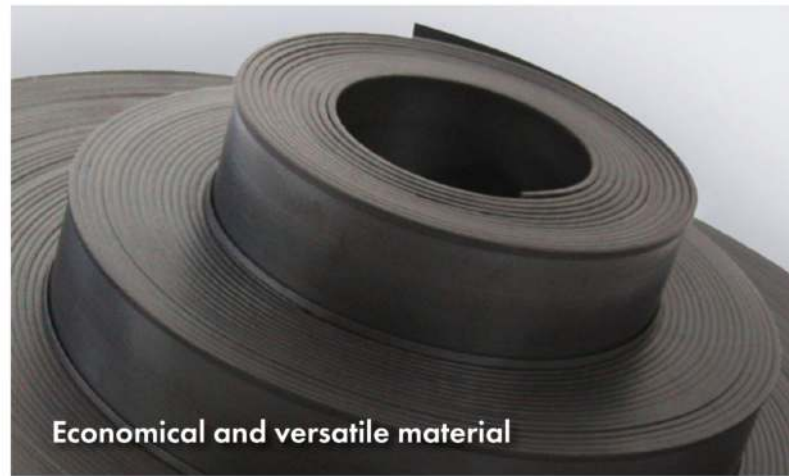

Economical and versatile material

- ➔ Ideal for cutting to your exact size
- ➔ Available in 5, 10 and 50M length rolls and in 9 heights
- ➔ Flexible to meet your changing needs
- ➔ Supplied complete with white card inserts and PVC cover strips
- ➔ Suitable for cold stores and chillers

These economical rolls of magnetic label holders are manufactured from a flexible material that enables the user to easily cut pieces into the length they require, using a knife or scissors. Each roll is supplied with a white card insert and a clear PVC cover strip.

Magnetic Label Holders - Roll Width

Ref	Size (h x w)	Pack
MLR1/5	15mm x 5M	1
MLR2X/5	20mm x 5M	1
MLR2/5	25mm x 5M	1
MLR3/5	30mm x 5M	1
MLR4/5	40mm x 5M	1
MLR5/5	50mm x 5M	1
MLR6/5	60mm x 5M	1
MLR7/5	70mm x 5M	1
MLR8/5	80mm x 5M	1
<hr/>		
MLR1/10	15mm x 10M	1
MLR2X/10	20mm x 10M	1
MLR2/10	25mm x 10M	1
MLR3/10	30mm x 10M	1
MLR4/10	40mm x 10M	1
MLR5/10	50mm x 10M	1
MLR6/10	60mm x 10M	1
MLR7/10	70mm x 10M	1
MLR8/10	80mm x 10M	1
<hr/>		
MLR1	15mm x 50M	1
MLR2X	20mm x 50M	1
MLR2	25mm x 50M	1
MLR3	30mm x 50M	1
MLR4	40mm x 50M	1
MLR5	50mm x 50M	1
MLR6	60mm x 50M	1
MLR7	70mm x 50M	1
MLR8	80mm x 50M	1

Label Holder profiles size
Height in mm

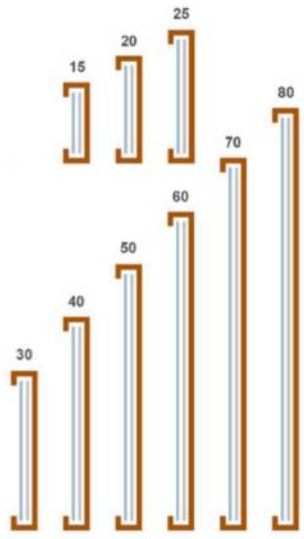

➔ For bespoke requirements please contact our sales office.

PVC Inserts

Additional clear PVC inserts are available for the label holders. Please specify whether it is to be used with the self-adhesive or magnetic holders. See [page 16](#) for [card inserts](#).

Ref	Description	To suit holder size (h x w)	Pack
LP18	PVC Insert	15mm x 80mm	100
LP28X	PVC Insert	20mm x 80mm	100
LP28	PVC Insert	25mm x 80mm	100
LP38	PVC Insert	30mm x 80mm	100
LP48	PVC Insert	40mm x 80mm	100
LP58	PVC Insert	50mm x 80mm	100
LP610	PVC Insert	60mm x 100mm	100
LP620	PVC Insert	60mm x 200mm	50
LP710	PVC Insert	70mm x 100mm	100
LP720	PVC Insert	70mm x 200mm	50

Ref	Description	To suit holder size (h x w)	Pack
LP820	PVC Insert	80mm x 200mm	50
LP150	PVC Insert	15mm x 500mm	20
LP250X	PVC Insert	20mm x 500mm	20
LP250	PVC Insert	25mm x 500mm	20
LP350	PVC Insert	30mm x 500mm	20
LP450	PVC Insert	40mm x 500mm	20
LP550	PVC Insert	50mm x 500mm	20
LP650	PVC Insert	60mm x 500mm	20
LP750	PVC Insert	70mm x 500mm	20
LP850	PVC Insert	80mm x 500mm	20

Magnetic Easy-wipe Racking Strip

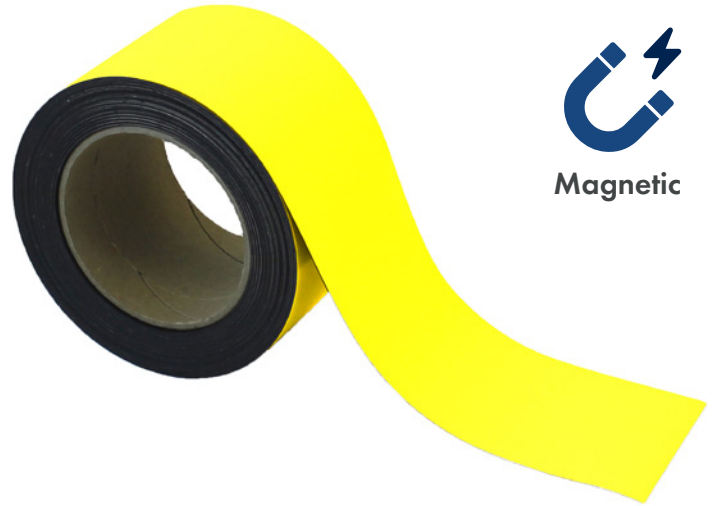

- ➔ Cost effective labelling system
- ➔ Gloss coloured surface (except matt black)
- ➔ Ideal for use as colour coding
- ➔ Write on – wipe off using a wet wipe marker pen
- ➔ Ideal for 5S and Lean environments



Available in 12 widths - 10mm to 100mm



The magnetic easy-wipe racking strip lets you quickly create labels and identification that's completely reusable and movable. The colour versions have the added benefit of allowing you to create colour-coded areas or highlight a particular message.

This product is extremely versatile and offers many other uses. For example, the narrow versions can be used as gridding tape on steel notice boards, and the wider rolls offer the ability to cut out or punch out different shapes.

All rolls are supplied in 10M lengths. Simply cut to the desired length, write on with a wet wipe marker pen and, if required, remove text with a damp cloth.



We Recommend!

Contact our sales team for Wet-Wipe Pens

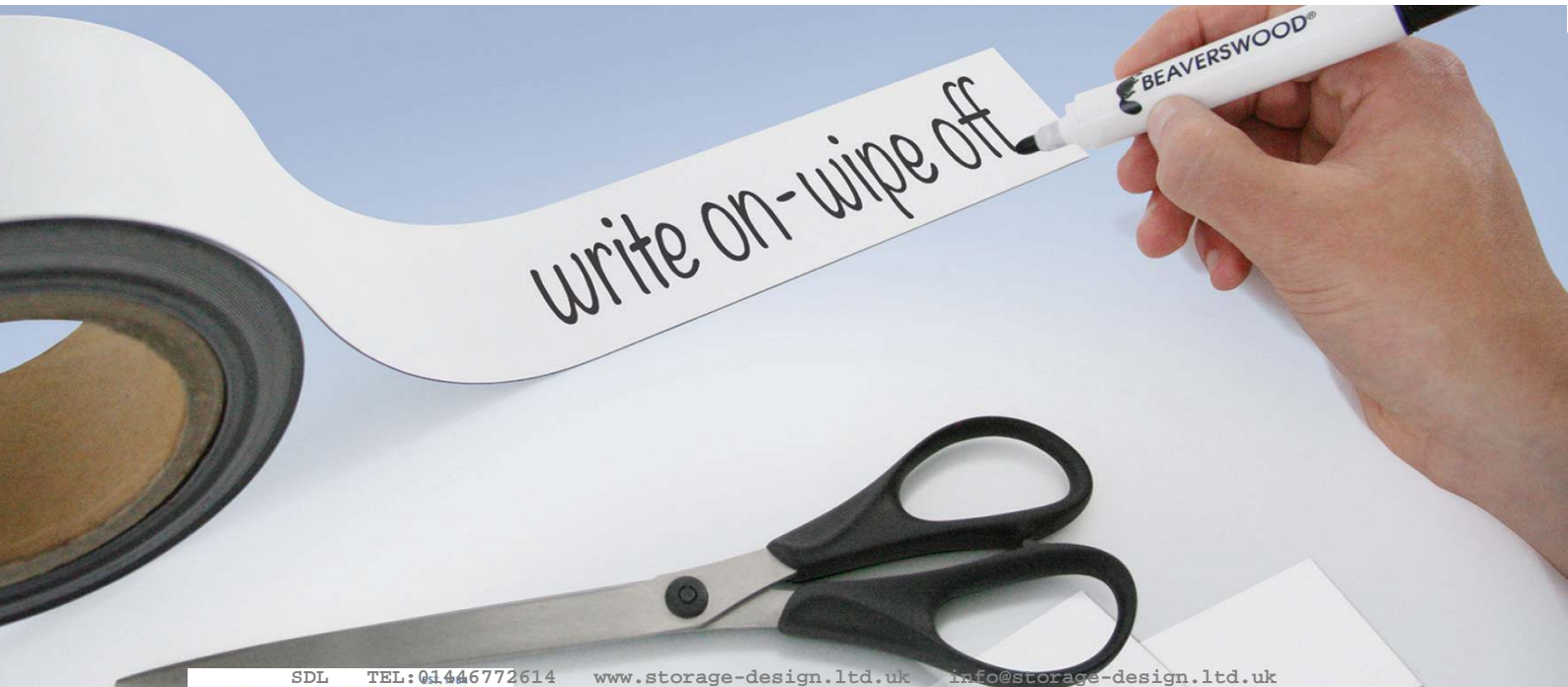

TICKETS & LABELLING



Allows for instant magnetic labelling

Available in 6 colours



Easily cut to required size



Write on - wipe off using a wet wipe marker pen

Size (h x w)	Quantity	Black Ref	White Ref	Blue Ref	Green Ref	Red Ref	Yellow Ref
10mm x 10M	1 Roll	MSR1BK	MSR1W	MSR1B	MSR1G	MSR1R	MSR1Y
15mm x 10M	1 Roll	MSR15BK	MSR15W	MSR15B	MSR15G	MSR15R	MSR15Y
20mm x 10M	1 Roll	MSR2BK	MSR2W	MSR2B	MSR2G	MSR2R	MSR2Y
25mm x 10M	1 Roll	MSR25BK	MSR25W	MSR25B	MSR25G	MSR25R	MSR25Y
30mm x 10M	1 Roll	MSR3BK	MSR3W	MSR3B	MSR3G	MSR3R	MSR3Y
40mm x 10M	1 Roll	MSR4BK	MSR4W	MSR4B	MSR4G	MSR4R	MSR4Y
50mm x 10M	1 Roll	MSR5BK	MSR5W	MSR5B	MSR5G	MSR5R	MSR5Y
60mm x 10M	1 Roll	MSR6BK	MSR6W	MSR6B	MSR6G	MSR6R	MSR6Y
70mm x 10M	1 Roll	MSR7BK	MSR7W	MSR7B	MSR7G	MSR7R	MSR7Y
80mm x 10M	1 Roll	MSR8BK	MSR8W	MSR8B	MSR8G	MSR8R	MSR8Y
90mm x 10M	1 Roll	MSR9BK	MSR9W	MSR9B	MSR9G	MSR9R	MSR9Y
100mm x 10M	1 Roll	MSR10BK	MSR10W	MSR10B	MSR10G	MSR10R	MSR10Y

Magnetic Self-adhesive Strip

- ➔ Makes anything magnetic
- ➔ Mounts items onto any steel surface
- ➔ 6 widths available
- ➔ No drilling required
- ➔ Industrial quality - 1.5mm thickness

Our magnetic strip is supplied in 6 widths, each backed with a strong permanent self-adhesive for mounting items onto steel surfaces.

This magnetic strip is ideal for many jobs in the office, factory or warehouse, eliminating the need for drilling, or other methods of fixing.

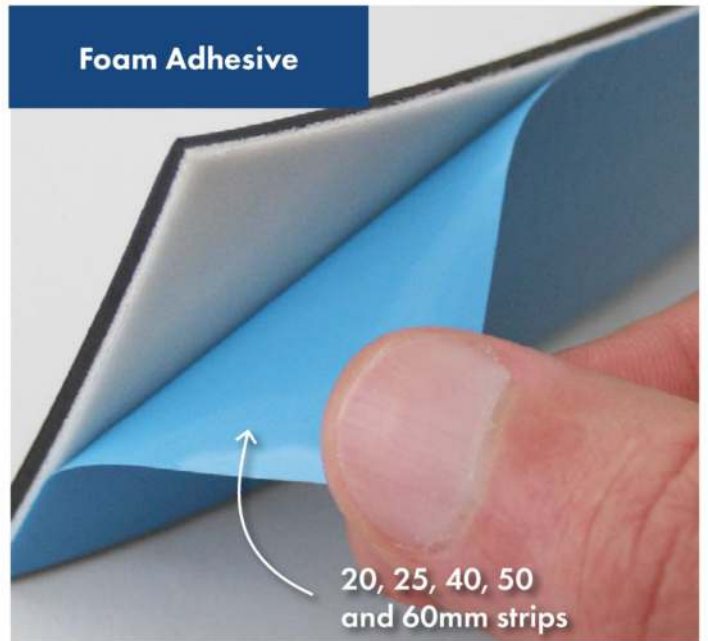
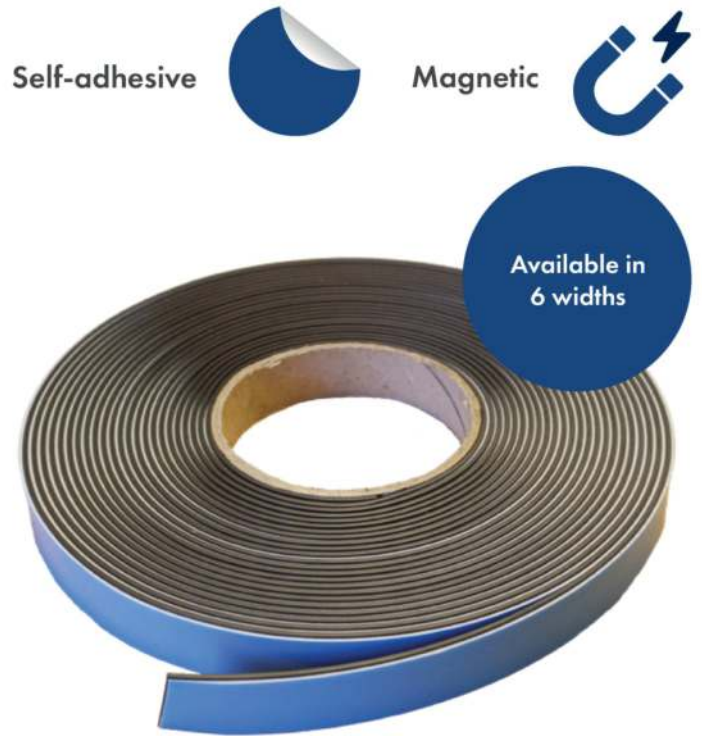

Magnetic Self-adhesive Strip

Ref	Size (h x w)	Adhesive
MSSA/13	13mm x 30M	Premium
MSSA/20	20mm x 10M	Foam
MSSA/25	25mm x 10M	Foam
MSSA/40	40mm x 10M	Foam
MSSA/50	50mm x 10M	Foam
MSSA/60	60mm x 10M	Foam



We Recommend!

See page 44 for our Weight Load ID Notices





Easily cut to size

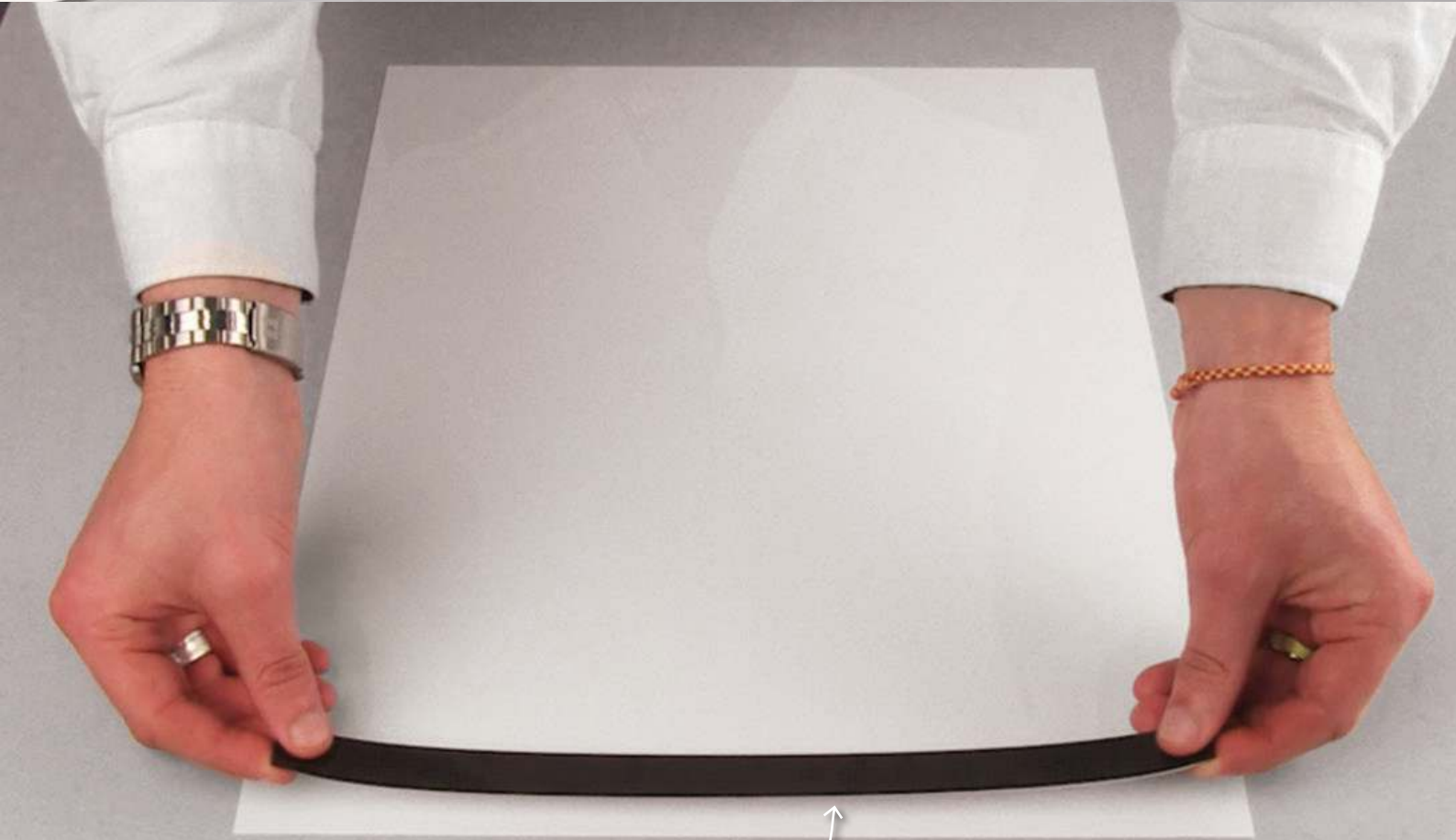

Ideal for attaching signs to ferrous metal surfaces

Magnetic Easy-wipe Location Markers

Write on -
wipe off



Magnetic



- ➔ Affixes to steel surfaces
- ➔ Write on - wipe off
- ➔ Quick and easy relocation
- ➔ Special sizes are available upon request

White magnetic location markers offer a quick and easy high visibility system of identifying locations, products or stock quantities etc.

Use a wet wipe marker pen to easily write on, update and move when required. Supplied in pre-cut single sized pieces.



We Recommend!



Contact our sales team
for Wet-Wipe Pens



Location markers shown are actual size (mm h x w)

LM158W 15 x 80

LM28W 20 x 80

LM258W 25 x 80

LM310W 30 x 100

A147

LM515W 50 x 150

Location Markers

Ref	Size (h x w)	Pack
LM158W	15mm x 80mm	100
LM28W	20mm x 80mm	100
LM258W	25mm x 80mm	100
LM38W	30mm x 80mm	100
LM48W	40mm x 80mm	100
LM58W	50mm x 80mm	100
LM310W	30mm x 100mm	100
LM410W	40mm x 100mm	100
LM510W	50mm x 100mm	100
LM610W	60mm x 100mm	100
LM710W	70mm x 100mm	100
LM810W	80mm x 100mm	100
LM105W	56mm x 105mm	100
LM515W	50mm x 150mm	100
LM815W	80mm x 150mm	100
LM1015W	100mm x 150mm	100
LM520W	50mm x 200mm	100
LM820W	80mm x 200mm	100
LM1020W	100mm x 200mm	100
LM219W	90mm x 210mm	10

Write on - wipe off using
a wet wipe marker pen

Wire Shelving Clip Holders

- ➔ Easily identify locations on wire shelving
- ➔ Pull forward front for loading
- ➔ Scan barcodes without removing insert
- ➔ Positioned flat or at an angled setting
- ➔ Holder can be reversed so higher levels are easier to read

↑ Flip vertically for high level view

High level view



Straight on view

Identifying locations on wire mesh shelving is difficult as traditional magnetic or self-adhesive holders don't suit wire mesh shelving. This clever holder solves the problem by using a quick and easy-to-use "clip-on" system.

This versatile holder can be used in three different formats: straight for shelves that are eye level, approx 33° for lower shelves, and approx 45° for the very bottom shelf, enabling easy reading. The holder is reversed for high level viewing.



33° angle

Wire Shelving Clip Holder Side Profile



45° angle

Supplied with white card inserts

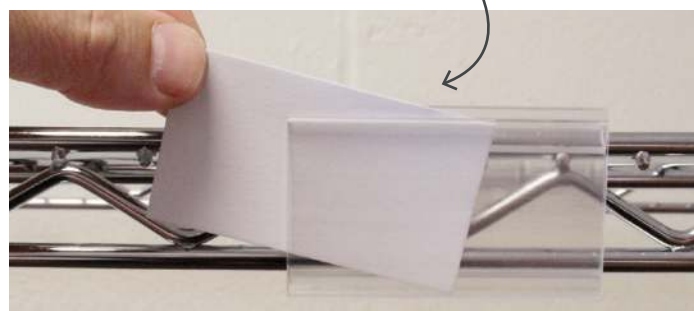

Spare Card Inserts

Wire Shelving Clip Holders

Ref	Size (h x w)	Pack
WSC47/12	43mm x 75mm	12
WSC47/50	43mm x 75mm	50

- ➔ Each holder is 43mm high x 75mm wide overall, supplied in packs of 12 or 50 with white card inserts.
- ➔ Suits wire shelves with maximum height of 35mm.

Ref	Size (h x w)	Pack
WSCC	43mm x 75mm	100

Ticket Pouches

Self-adhesive and Magnetic

- ➔ Cost effective ticket pouches
- ➔ Clear front enables barcodes to be scanned
- ➔ Available in 4 sizes and 5 colours
- ➔ Self-adhesive or magnetic fixing
- ➔ Supplied with white card inserts
- ➔ Ideal for 5S and Lean manufacturing

Highlight information using this economical range of coloured PVC ticket pouches. They feature a flexible pull forward clear front and coloured back.

There are 4 size options and 5 colours to choose from, designed for use on all types of shelving and racking. The colourful backing can be used for identifying picking areas, while the clear front allows a barcode insert to be scanned without removing the ticket.

The self-adhesive pouch is permanent, whereas the magnetic version can be easily relocated.

Magnetic versions of our ticket pouches are ideal for locations that change frequently, as well as being perfect for use on most steel surfaces including shelving, racking, and steel office cupboards, etc.



We Recommend!

See pages 28-31 for code labelling and printing





The clear front allows barcodes to be scanned



Spare Card Inserts

Ref	To Suit Holder	Pack
TPC310	30mm x 100mm	100
TPC412	40mm x 120mm	100
TPC610	60mm x 100mm	100
TPC614	60mm x 140mm	100

Self-adhesive Ticket Pouches

Ref	Description	Size (h x w)	Pack
Yellow - supplied as standard unless specified			
SAP310Y	Self-adhesive	30mm x 100mm	100
SAP412Y	Self-adhesive	40mm x 120mm	100
SAP610Y	Self-adhesive	60mm x 100mm	100
SAP614Y	Self-adhesive	60mm x 140mm	100
Blue			
SAP310B	Self-adhesive	30mm x 100mm	100
SAP412B	Self-adhesive	40mm x 120mm	100
SAP610B	Self-adhesive	60mm x 100mm	100
Black			
SAP310BK	Self-adhesive	30mm x 100mm	100
SAP412BK	Self-adhesive	40mm x 120mm	100
SAP610BK	Self-adhesive	60mm x 100mm	100
SAP614BK	Self-adhesive	60mm x 140mm	100
Green			
SAP310G	Self-adhesive	30mm x 100mm	100
SAP412G	Self-adhesive	40mm x 120mm	100
SAP610G	Self-adhesive	60mm x 100mm	100
SAP614G	Self-adhesive	60mm x 140mm	100
Red			
SAP310R	Self-adhesive	30mm x 100mm	100
SAP412R	Self-adhesive	40mm x 120mm	100
SAP610R	Self-adhesive	60mm x 100mm	100

➔ SAP614 is not available in blue or red as standard. Please get in touch for minimum order quantities.

Magnetic Ticket Pouches

Ref	Description	Size (h x w)	Pack
Yellow - supplied as standard unless specified			
MP310Y	Magnetic	30mm x 100mm	100
MP412Y	Magnetic	40mm x 120mm	100
MP610Y	Magnetic	60mm x 100mm	100
MP614Y	Magnetic	60mm x 140mm	100
Blue			
MP310B	Magnetic	30mm x 100mm	100
MP412B	Magnetic	40mm x 120mm	100
MP610B	Magnetic	60mm x 100mm	100
MP614B	Magnetic	60mm x 140mm	100
Black			
MP310BK	Magnetic	30mm x 100mm	100
MP412BK	Magnetic	40mm x 120mm	100
MP610BK	Magnetic	60mm x 100mm	100
MP614BK	Magnetic	60mm x 140mm	100
Green			
MP310G	Magnetic	30mm x 100mm	100
MP412G	Magnetic	40mm x 120mm	100
MP610G	Magnetic	60mm x 100mm	100
MP614G	Magnetic	60mm x 140mm	100
Red			
MP310R	Magnetic	30mm x 100mm	100
MP412R	Magnetic	40mm x 120mm	100
MP610R	Magnetic	60mm x 100mm	100
MP614R	Magnetic	60mm x 140mm	100

Mag-Grip Self-adhesive Magnetic Clip

Self-adhesive



- ➔ A document clip featuring strong magnets to secure materials within its grip
- ➔ Easily display documents within the magnetic clip and attach it to a wide range of surfaces using the self-adhesive backing
- ➔ Available in two sizes to fit both A4 and A5 documents
- ➔ Suitable for both landscape and portrait orientations
- ➔ Comes in packs of 10 or 50

This easy-to-use magnetic clip is the perfect solution to securely grip notes and documents.

Featuring a self-adhesive backing for attachment to any smooth, flat, sealed surface, such as cabinets, steel shelving, racking, refrigerators, whiteboards, doors, etc.

Simply peel off the back of the adhesive strip, attach to your chosen surface, and it's ready to go. Just open the clip, insert a document, and close again. **Easy!**

Perfect for holding documents, posters, information materials, order tickets, or notices, making it ideal for offices, retail, warehouses, kitchens, education, or homes.



Dimensions

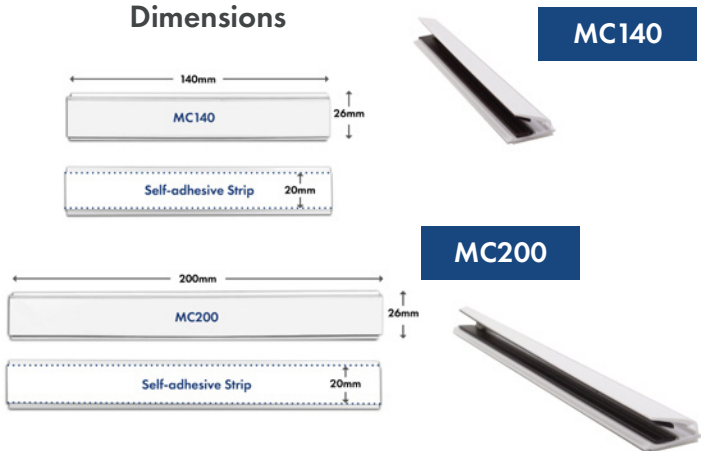

Mag-grip

Ref	For Use With	Size (h x w)	Pack
MC140/10	A5	26mm x 140mm	10
MC200/10	A4	26mm x 200mm	10
MC140/50	A5	26mm x 140mm	50
MC200/50	A4	26mm x 200mm	50

TICKETS & LABELLING



Easy to pull open



Easily replace documents when required

Your Complete Labelling Solution

From consultation to design, to print and install – Beaverswood® cover it all!

Let's be honest, planning and project managing the install of new warehouse racking and location labels can be mind-boggling.

There are so many aspects to factor in, from whether you need self-adhesive or magnetic fixings, to alpha or numeric systems (or a bit of both), to which type of barcoding is required, to the differences between split beam, summary, and upright labels – the list goes on!

We can take a load off your mind by being **your trusted partner** through the entire process from start to finish.

With **100+ years combined experience** in the label industry, you can rely on our specialist knowledge to ensure delivery of an effective labelling system for your warehouse.

Can't I just get my in-house team to label everything?

We might sound biased, but we highly recommend using an experienced labelling manufacturer to install your location labelling system.

At first glance, label installs might seem like an easy job (how hard can it be to slap some stickers around the place, right?). Yet we guarantee a DIY installation project will rarely go smoothly.

This is because of:

- ➔ **Loss of productivity** – using internal warehouse workers will create its own set of labour challenges, especially when factored with our second point...
- ➔ **Overruns** – DIY installations often take far longer to complete than those carried out by specialists, due to the level of expertise required to install signs, aisle and bay markers, dock signs, hanging zone markers, and more.
- ➔ **Mistakes** – out of sequence labels means costly re-prints and re-installations – eating up more valuable time and labour resources.
- ➔ **Poor end results** – in-house workers rarely have the experience required to ensure the labels effectively adhere to the surface, leading to labels that curl, peel, and eventually fall to the floor.



Let the experts handle it...

Save yourself the time, cost, and headache of a DIY install by contacting us today.

We can design and manufacture labels to suit your needs, including the incorporation of barcodes, directional arrows, and check digits as required. We can also provide full colour lamination on our labels, which not only enhances the look and feel of them but also protects them from spills and abrasions – not to mention dirt, grease, and smudges can be cleaned off more easily.

Additionally, we can carry out label installations in either new or occupied warehouses, working around your operations. Our service includes advice and consultation in the planning stage, hire of equipment, and installation fulfilled by trained and qualified personnel.

So, whether you're just after label printing or the full works including installation, we're here to help you every step of the way.



Get in touch to discuss your printing or installation requirements on 0118 979 6096.

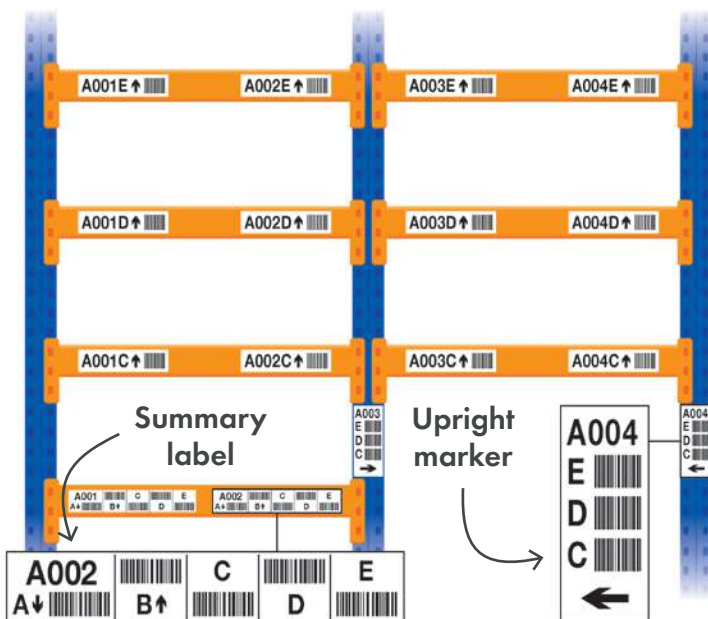

Already know what labels you need?

If this isn't your first warehouse labelling rodeo, simply contact us for a quotation with the following information:

- ➔ Quantity of labels and/or number of locations
- ➔ Typical code
- ➔ Colour requirement (full colour laminated available)
- ➔ Approximate label size
- ➔ Base material (paper based, vinyl, polyester, magnetic, block out, etc.)
- ➔ Height to top beam (for install purposes)
- ➔ Whether you require print, install, or both

A Label For Every Occasion

Self-adhesive



Magnetic



Not sure what type of label you need? Here's a handy guide...

Single Location Labels

A location label for each pallet location. This can incorporate location code, directional arrows, barcode, and check digits.

We recommend including barcodes on all locations for stock-taking purposes, even if you don't have man-up trucks.



Split Beam Labels

Ideal for locations on the floor and first beam level. The double text at eye level reduces the number of labels required for manufacture and installation.

These labels can include location code, directional arrows, barcodes, and check digits.



Summary Labels

Labels positioned on the first beam level detailing the locations and barcodes for all upper levels.

Suitable for use where man-up trucks aren't available, the user can scan the location from the ground without the need to leave the truck.



Upright Labels

Manufactured on a rigid plate, the upright markers are ideal for use in walkways, fire exits, or tunnel bays.

The plates act like the summary label and offer the user the ability to scan upper-level locations from the ground.



Wipe clean



Types of fixings and materials

Self-adhesive

These come in a variety of materials, be it polyester, paper, or vinyl. They provide a cost-effective, permanent solution for ambient room temperature warehousing.

Block-out

If you already have self-adhesive labels affixed to your racking but need to replace them, we're sorry to say they can prove tricky to remove! If you use thin paper to cover over the old label, barcode scanners may pick up the code on the label behind.

For this reason, block-out labels are a wise choice as the material is thicker to ensure the old code can't be accidentally scanned. They can be supplied plain or with the new code already printed on.



Magnetic

These are perfect for when you need a rack label that can be easily removed and switched to a different location. They're also great for cold store environments as they don't fall off or become illegible.

Don't forget Label Holders!

A labelling system only works for as long as the labels remain readable. As such, we highly recommend investing in label holders to protect them from scratches and general wear and tear (from forklifts, for example).

We offer a range of label holders which come with clear PVC covers to protect the label from dirt and abrasion, while still allowing barcode scanning. They're also durable and reusable, meaning if you buy from Beaverswood®, you only buy once!





Characters shown are actual size (mm)

F3
36 per card



F4
12 per card



F5
12 per card



When ordering...

Simply select the size you require, taking into account the tile size and confirm the quantity of each card required.



➔ *Minimum order of 20 cards. These can be mixed sizes, letters, numbers and arrows.*

Numbers and Letters

Complete Self-adhesive Packs

Self-adhesive

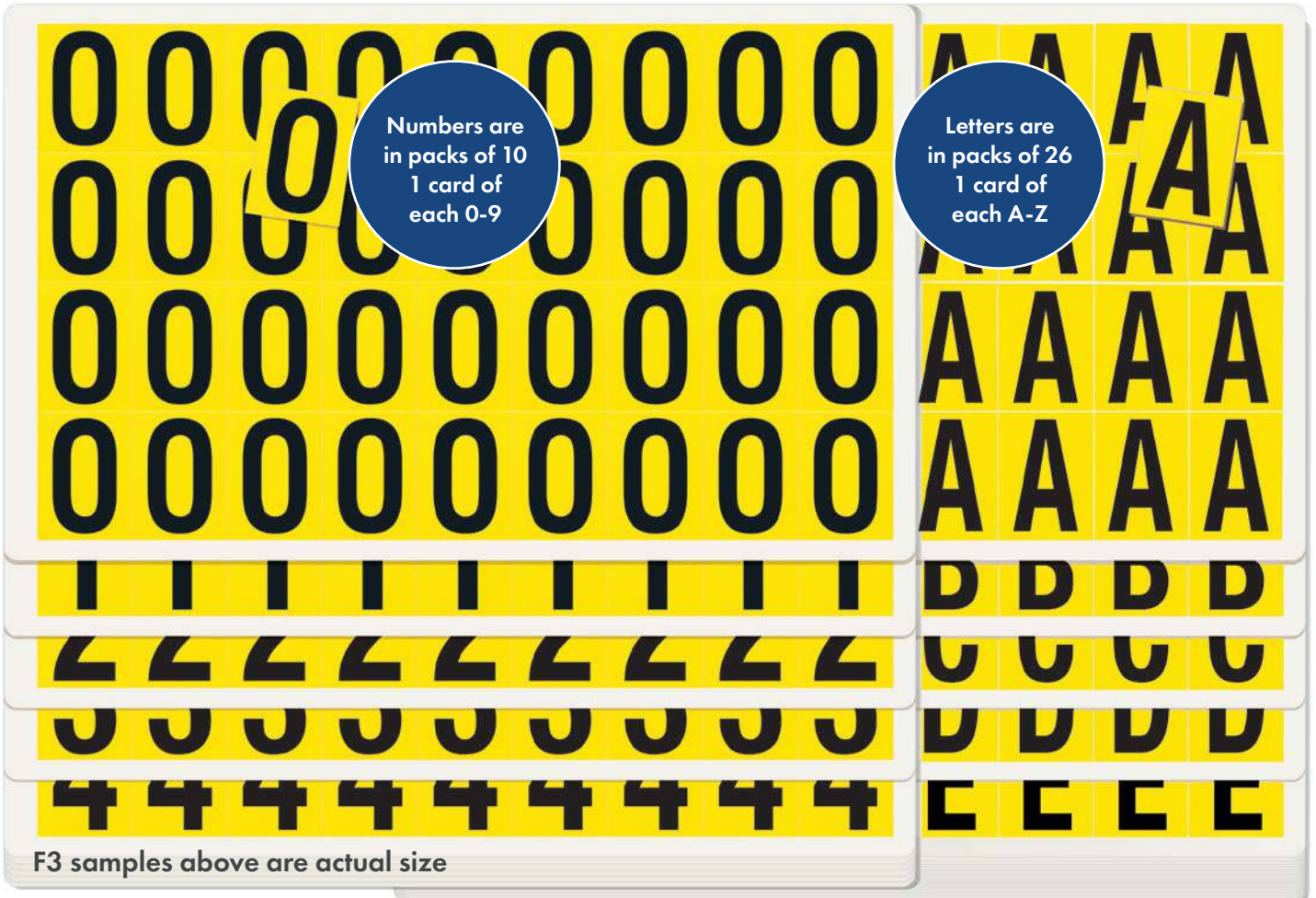

F3 samples above are actual size

- ➔ Choice of 6 different sizes
- ➔ 1 card of each character
- ➔ Supplied in complete packs of numbers 0-9 or letters A-Z
- ➔ Clean peel labelling - leaves no residue
- ➔ Cost effective method of creating bespoke identification



Complete Packs of Numbers

Ref	Size (h x w)	Character Height	Characters Per Card	Colour
F3	19mm x 14mm	16mm	36	Yellow
F4	38mm x 21mm	26mm	12	Yellow
F5	56mm x 21mm	50mm	12	Yellow
F6	90mm x 38mm	75mm	6	Yellow
F7	130mm x 45mm	100mm	5	Yellow
F8	230mm x 140mm	160mm	1	Yellow

Complete Packs of Letters

Ref	Size (h x w)	Character Height	Characters Per Card	Colour
F3	19mm x 14mm	16mm	36	Yellow
F4	38mm x 21mm	26mm	12	Yellow
F5	56mm x 21mm	50mm	12	Yellow
F6	90mm x 38mm	75mm	6	Yellow
F7	130mm x 45mm	100mm	5	Yellow
F8	230mm x 140mm	160mm	1	Yellow



Characters shown are actual size (mm)



When ordering...

Simply select the size you require, taking into account the tile size and confirm the quantity of packs.



Packs of identical cards of characters, numbers 0-9 and letters A-Z

Numbers and Letters Magnetic

- ➔ Magnetic tiles on sheets with either mixed alpha or numeric digits
- ➔ Two heights - 43mm with a 39mm high digit or 23mm with a 17mm high digit
- ➔ Available with black digits on a white or yellow background
- ➔ Die-cut A4 sheets



Available in 23mm and 43mm tile heights

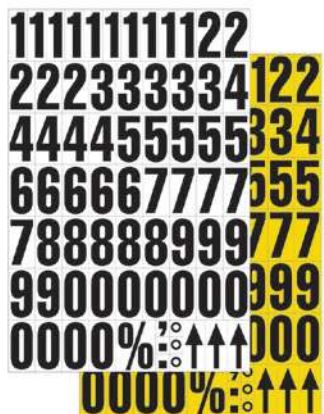

Allows for fast and easy labelling on any magnetic receptive steel surface



Each sheet consists of the following characters:

23mm Numbers

Ox31 1x31 2x17 3x17 4x17 5x17 6x17 7x17 8x17 9x17

23mm Letters

Ax12 Bx6 Cx8 Dx7 Ex21 Fx7 Gx7 Hx6 Ix16 Jx4
Kx5 Lx7 Mx8 Nx12 Ox12 Px5 Qx3 Rx9 Sx8 Tx9
Ux8 Vx7 Wx3 Xx2 Yx2 Zx4

43mm Numbers

Ox11 1x10 2x5 3x5 4x5 5x5 6x5 7x5 8x5 9x5

43mm Letters

Ax3 Bx2 Cx2 Dx2 Ex4 Fx2 Gx2 Hx2 Ix3 Jx1
Kx1 Lx2 Mx2 Nx3 Ox2 Px2 Qx1 Rx3 Sx3 Tx3
Ux3 Vx2 Wx1 Xx1 Yx1 Zx2

Magnetic Numbers and Letters

Ref	Size (height)	Type	Colour
M23MIXW/N	23mm	Numbers	White
M23MIXY/N	23mm	Numbers	Yellow
M23MIXW/L	23mm	Letters	White
M23MIXY/L	23mm	Letters	Yellow
M43MIXW/N	43mm	Numbers	White
M43MIXY/N	43mm	Numbers	Yellow
M43MIXW/L	43mm	Letters	White
M43MIXY/L	43mm	Letters	Yellow

Consecutive Number Tiles

Self-adhesive



- ➔ Sets of high visibility labels from 01 to 100
- ➔ Easy peel self-adhesive fixing
- ➔ Printed black on yellow
- ➔ For instant identification
- ➔ Available from stock with two sizes to choose from



Easily label anything from pick bins to racking with a numeral system

Consecutive Number Tiles

Ref	Size (h x w)	Digit (height)	Pack
CN23	25mm x 30mm	20mm	100
CN50	50mm x 50mm	40mm	100

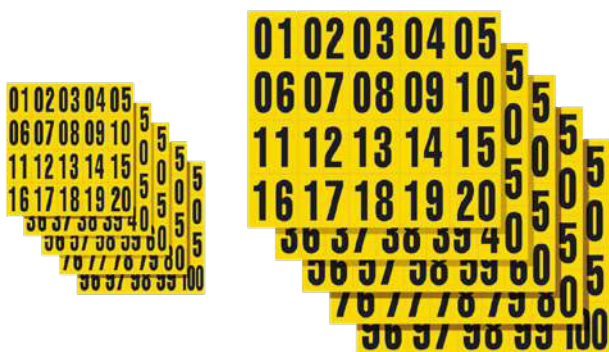

Identification Tiles

Self-adhesive and Magnetic

Self-adhesive



Magnetic



- ➔ Highly visible tiles printed black on yellow or black on white
- ➔ Printed to your sequence with 1 or 2 characters
- ➔ Choice of self-adhesive for permanent locations or magnetic for frequently changing locations
- ➔ Price includes printing

Identification Tiles

Ref	Size (h x w)	Fixing	Pack
TA50	50mm x 50mm	Self-adhesive	1
TA70	70mm x 70mm	Self-adhesive	1
TA90	90mm x 90mm	Self-adhesive	1
TM50	50mm x 50mm	Magnetic	1
TM70	70mm x 70mm	Magnetic	1
TM90	90mm x 90mm	Magnetic	1

- ➔ Please note there is a £25.00 minimum order for this product.
- ➔ Please specify when ordering which colour you require.



Pallet Marker



- ➔ Enables quick and easy pallet identification
- ➔ Water, grease and oil resistant
- ➔ Adjustable fit

Identifying stock on pallets has always been a problem. Our Pallet Marker is designed to fit securely around the corner of a Euro pallet, yet is adjustable to fit most other pallets. Manufactured in flexible white PVC, this unique Pallet Marker can be written on with a marker pen, or labels can be adhered to its smooth surface.



Pallet Marker

Ref	Size (h x w)	Pack
PM/50	75mm x 470mm	50

Stock Indicator Wheel



Our traffic light wheel can simply be rotated to show the level of stock that is available. **Green** for good, **Amber** for getting low and **Red** for out of stock. The indicator wheel is available with self-adhesive, magnetic or wire-clip fixings.

- ➔ Simple 3 colour coding system to show stock availability
- ➔ Visual aid when stock is not visible
- ➔ Plate dimensions: 90mm high (110mm overall) x 140mm wide

Stock Indicator Wheel

Ref	Fixing	Pack
SIWA/10	Self-adhesive	10
SIWM/10	Magnetic	10
SIWW/10	Wire-clip	10

Stock Identity Slider

- ➔ System to show stock availability
- ➔ Aggressive adhesive fixing
- ➔ Slider is 30mm high x 100mm wide
- ➔ Ideal for use on racking and shelving

Our 2 colour stock indicator slider has a permanent aggressive adhesive fixing and is simple to use.

Helps to instantly show where products are running low without the need to view inside boxes. The white slider can be written on (or affix a label) with the product code or stock locations to help identify the stored product.

Available in packs of 50 or 100.



We Recommend!

See pages 28-31 for code labelling and printing

LU26G2

Stock Identity Slider

Ref	Size	Fixing	Pack
SISA/50	30mm x 100mm	Self-adhesive	50
SISA/100	30mm x 100mm	Self-adhesive	100



Signs

We offer an extensive range of warehouse signs and markers to clearly identify racking and pallet locations, highlight hazards or dangers, and provide crucial rack-loading information to keep operations running smoothly and safely.

We can also design and manufacture bespoke signs and markers – simply get in touch with your requirements.



SIGNS

Bay Markers

Self-adhesive



Magnetic

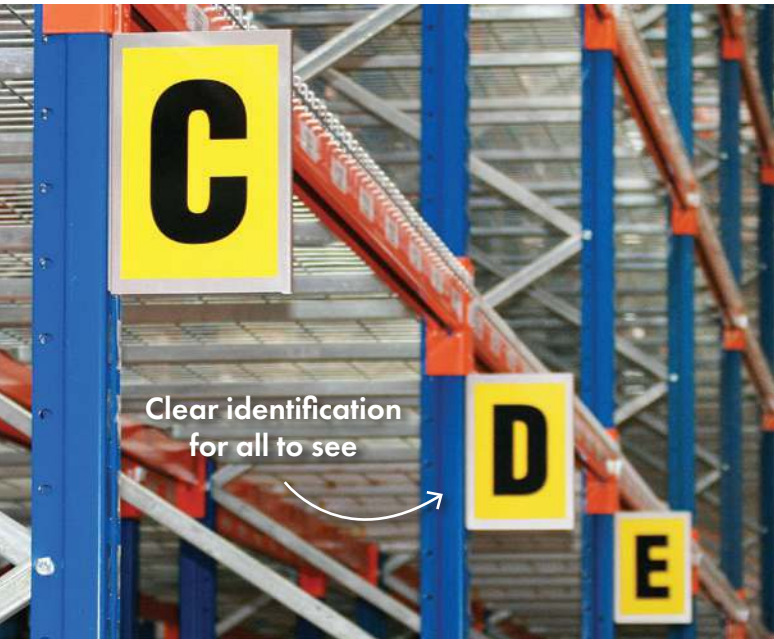

- ➔ Clear Identification
- ➔ Fixed or relocated in seconds
- ➔ Available in single or double digit markers
- ➔ No drilling required
- ➔ Magnetic or self-adhesive fixing
- ➔ Suitable for large installations



BA1 - Front view



BA1 - Rear view

Our high visibility Bay Markers offer clear identification throughout the warehouse.

A formed aluminium section with either a magnetic or self-adhesive edge, enables the marker to be easily mounted onto steel racking without drilling.

When locations need to be changed the magnetic marker can simply be lifted and relocated.

Please note adhesive characters are supplied separately and can be applied to both the front and back.

Bay Markers

Ref	Fixing	Size (h x w)	Accommodates
BM1	Magnetic	260mm x 167mm	1 character
BA1	Self-adhesive	260mm x 167mm	1 character
BM2	Magnetic	260mm x 310mm	2 characters
BA2	Self-adhesive	260mm x 310mm	2 characters
Character - Numbers and Letters			
F8	Self-adhesive	230mm x 140mm	

➔ When ordering, please specify characters and quantities required. Character not applied.



High Visibility Characters

High visibility black on yellow vinyl character - A to Z and 0 to 9 characters available.

The characters can be applied to the front and back of the marker allowing the location to be viewed from both sides.



Angled Aisle Markers

- ➔ Angled aisle markers for prominent visibility
- ➔ Available in a choice of fixings - magnetic or self-adhesive
- ➔ Price includes printing of characters

Our range of highly visible angled aisle markers are available with either magnetic or self-adhesive fixings and come in a choice of white or yellow.

Included in the price, the AM1F is supplied with one self-adhesive printed label for the user to apply. The label can be applied to the front or back depending on whether the marker is to be used right or left handed.

The AM1T is supplied with two printed labels.

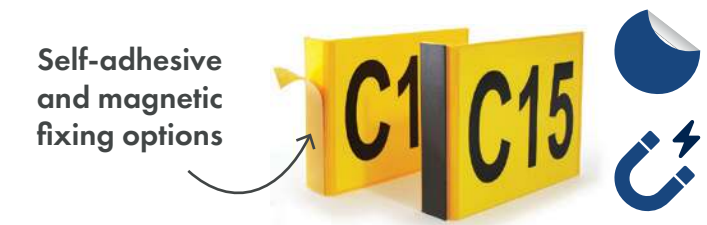

Angled Aisle Markers

Ref	Size (h x w)	Characters	Fixing	Colour
AM1F	95mm x 130mm	Up to 3 characters	Self-adhesive	White/Yellow
AM1FM	95mm x 130mm	Up to 3 characters	Magnetic	White/Yellow
AM1T	95mm x 130mm x 130mm	Up to 3 characters on each side	Self-adhesive	White/Yellow
AM1TM	95mm x 130mm x 130mm	Up to 3 characters on each side	Magnetic	White/Yellow

- ➔ When ordering, please specify sequencing.
- ➔ Please state colour required when ordering - (/Y) Yellow and (/W) White.

Projection Markers

- ➔ Larger angled markers for enhanced visibility
- ➔ Manufactured to order in various sizes to suit your requirements
- ➔ Available in styrene or foamex



➔ Please contact us for details on this bespoke product.

Our larger angled aisle markers are manufactured in various sizes and materials to suit your requirements. Generally manufactured in 1.5mm yellow or white styrene or 3mm foamex. These markers can be printed on two faces for multi angled enhanced visibility with digits or just about any other information of your choice.

They can be supplied either pre-drilled or with self-adhesive fixing tape for ease of application.

Aisle Markers

- ➔ Markers to identify aisles or bays
- ➔ Prominent identification
- ➔ Prices include printing of required characters up to the maximum allowed

Our range of robust end of aisle identification markers are available in various sizes, colours and designs for instant aisle locating.

These aisle markers are suitable for use in factory, warehouse or office environments.

Each aisle marker is supplied pre-drilled unless stated.

Bespoke markers can be manufactured incorporating directional arrows, logos, and entry/no entry symbols etc. Contact our sales office for further details.



Quickly and easily locate the right aisle



Aisle Markers

Ref	Size (h x w)	Characters	Colour
AM2/1	220mm x 270mm	1 x 180mm	Yellow
AM2/2	220mm x 270mm	2 x 180mm	Yellow
AM3/1	220mm x 450mm	1 x 180mm	White/Yellow
AM3/2	220mm x 450mm	2 x 180mm	White/Yellow
AM3/3	220mm x 450mm	3 x 180mm	White/Yellow
AM3X/1	300mm x 300mm	1 x 180mm	White/Yellow
AM3X/2	300mm x 300mm	2 x 180mm	White/Yellow
AM4	660mm x 343mm	1 x 500mm	Yellow

➔ Larger styrene markers up to 600mm x 600mm are available to order. Other materials and sizes are also available - please enquire for details.

Shelving Aisle Marker

- ➔ High visibility marker for shelving
- ➔ Price includes printing of up to 3 characters

This aisle marker is the ideal, highly visible and economical solution for shelving aisle and bay identification. The marker is supplied pre-drilled in 4 corners for cable tie or screw fixing.

Alternatively our Magnetic Self-adhesive Strip can be applied to the rear of the marker for quick and easy fixing.

➔ When ordering, please specify sequencing and colour option.



We Recommend!

For quick fixing solution, see page 20 for our Magnetic Self-adhesive Strip

Shelving Aisle Marker

Ref	Size (h x w)	Characters	Colour
AM1	95mm x 160mm	Up to 3 characters on one side	White/Yellow

Weight Load Identification PVC Notices

- ➔ Signs to identify weight loadings and procedures
- ➔ Choice of 5 different designs
- ➔ Manufactured from PVC
- ➔ Supplied blank from stock
- ➔ Price includes black digit printing with contact details and loadings

Tough and durable PVC weight load notices, detailing procedures for the maintenance of racking structures.

The range covers shelf/pallet racking, cantilever racking, drive-thru racking and mezzanine floors.

All our notices incorporate the latest Health and Safety recommendations. The signs can be overprinted with your corporate logo, address and contact details.



BLS1 Shelving & Racking (356mm x 254mm)

BLS5

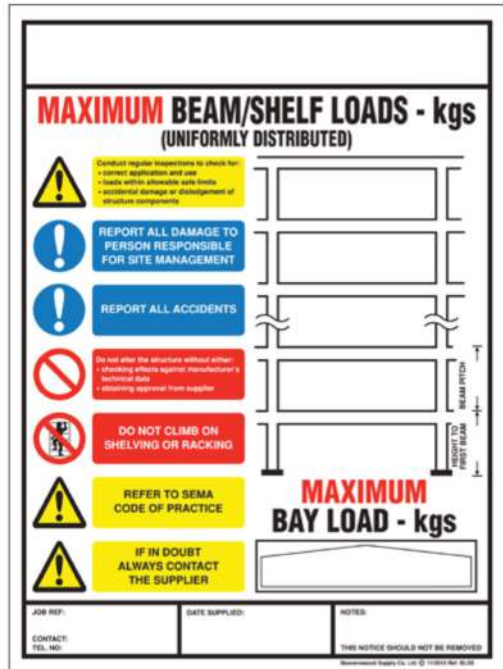

Please see page 46 for further designs



BLS1



Weight Load Identification - PVC Notices

Ref	Suitable For	Size (h x w)
BLS1	Shelving & Racking	356mm x 254mm
BLS5	Pallet Racking	470mm x 350mm



We Recommend!

See page 20 for our Magnetic Self-adhesive Strip

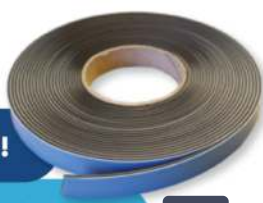

- ➔ All of our notices can be colour printed with your logo, etc. (subject to minimum quantity). Please call for further details.
- ➔ Templates can be emailed to you upon request, simply enter your details and forward them with your purchase order.

YOUR COMPANY DETAILS HERE

MAXIMUM BEAM/SHELF LOADS - kgs (UNIFORMLY DISTRIBUTED)



Conduct regular inspections to check for:
• correct application and use
• loads within allowable safe limits
• accidental damage or dislodgement of structure components



REPORT ALL DAMAGE TO PERSON RESPONSIBLE FOR SITE MANAGEMENT



REPORT ALL ACCIDENTS



Do not alter the structure without either:
• checking effects against manufacturer's technical data
• obtaining approval from supplier



DO NOT CLIMB ON SHELVING OR RACKING



REFER TO SEMA CODE OF PRACTICE



IF IN DOUBT ALWAYS CONTACT THE SUPPLIER

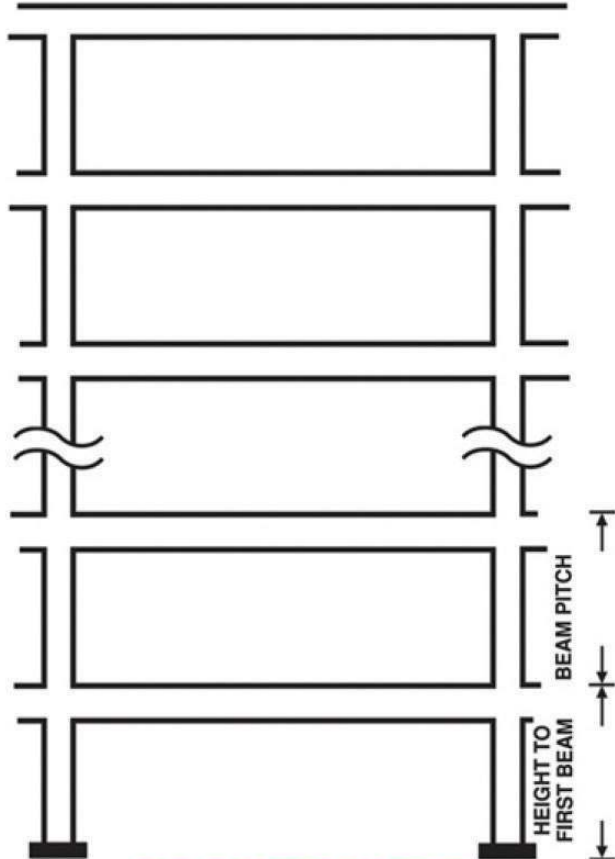

MAXIMUM BAY LOAD - kgs

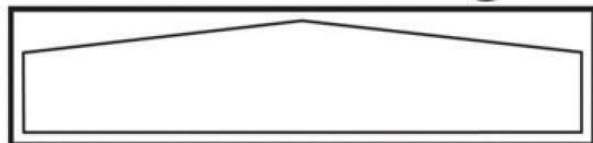

JOB REF:

DATE SUPPLIED:

NOTES:

CONTACT:
TEL. NO:

THIS NOTICE SHOULD NOT BE REMOVED

Beaverswood Supply Co. Ltd © 11/2013 Ref. BLS5

Weight Load Identification PVC Notices

BLS2 Cantilever Racking
(356mm x 254mm)

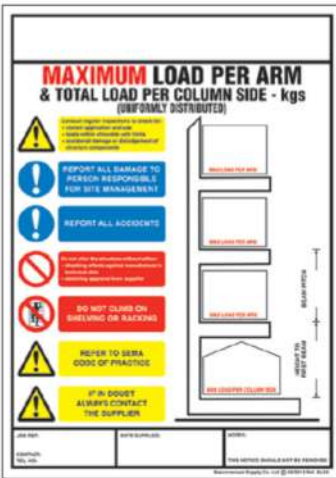

BLS3 Drive Thru' Racking
(356mm x 254mm)



BLS4 Mezzanine Floor
(210mm x 295mm)



Weight Load Identification - PVC Notices

Ref	Suitable For	Size (h x w)
BLS2	Cantilever Racking	356mm x 254mm
BLS3	Drive Thru' Racking	356mm x 254mm
BLS4	Mezzanine Floor	210mm x 295mm



Weight Load Identification Styrene Notices

- ➔ Landscape format load notices
- ➔ Choice of 2 standard designs
- ➔ Manufactured from styrene
- ➔ Supplied blank or label printed with black text at no extra charge

These landscape weight load notices for racking and shelving are made from white, rigid styrene. They detail all relevant information relating to the safe load limits of racking and shelving.

We can supply them blank or printed with black text. Colour print is also available (subject to quantity).

Weight Load Identification - Styrene Notices

Ref	Suitable For	Size (h x w)
BLS6	Pallet Racking	297mm x 420mm
BLS7	Shelving Racking	215mm x 220mm

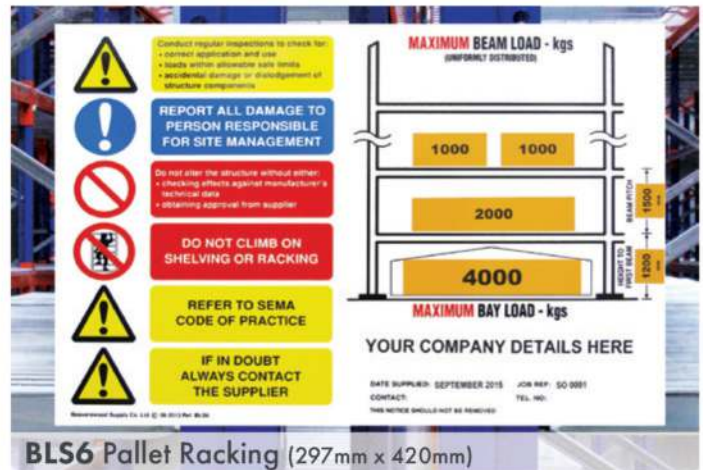

BLS7 Shelving Racking
(215mm x 220mm)

Can be labelled with weight loads and company information

SIGNS

Information Labels



Important information for a safe warehouse environment

MAX UDL 2000 KGS

- ➔ Highly visible information labels
- ➔ Price includes printing to your design
- ➔ Black text on white or yellow background
- ➔ Choice of 4 standard sizes - other sizes are available
- ➔ Magnetic or self-adhesive fixing

Our highly visible labels were originally designed to highlight Max UDL or SWL on shelving and pallet racking beams, but these labels can be used virtually anywhere and on most surfaces.

Simply select the size, confirm the text, pictograms, colour and quantity required.

Information Labels

Ref	Fixing	Size (h x w)	Colours
BL23	Self-adhesive	25mm x 200mm	White/Yellow
BL53	Self-adhesive	50mm x 300mm	White/Yellow
BL73*	Self-adhesive	70mm x 300mm	White/Yellow
BL93*	Self-adhesive	90mm x 300mm	White/Yellow
BL23M	Magnetic	25mm x 200mm	White/Yellow
BL53M	Magnetic	50mm x 300mm	White/Yellow
BL73M*	Magnetic	70mm x 300mm	White/Yellow
BL93M*	Magnetic	90mm x 300mm	White/Yellow

- ➔ *Print may appear on two lines.
- ➔ Please note there is a minimum order value of £25.00.

MAX SHELF LOAD 100 KG

1200 Kg
UNIFORMLY DISTRIBUTED
LOAD PER LEVEL

CLEANING STATION CT01

1500 KG
UNIFORMLY DISTRIBUTED LOAD PER LEVEL

**KEEP ALL LIMBS
INSIDE CAB**

**RESTRICTED
AREA**

3000 KG

MAX UDL 2000 KGS

GOODS IN BAY

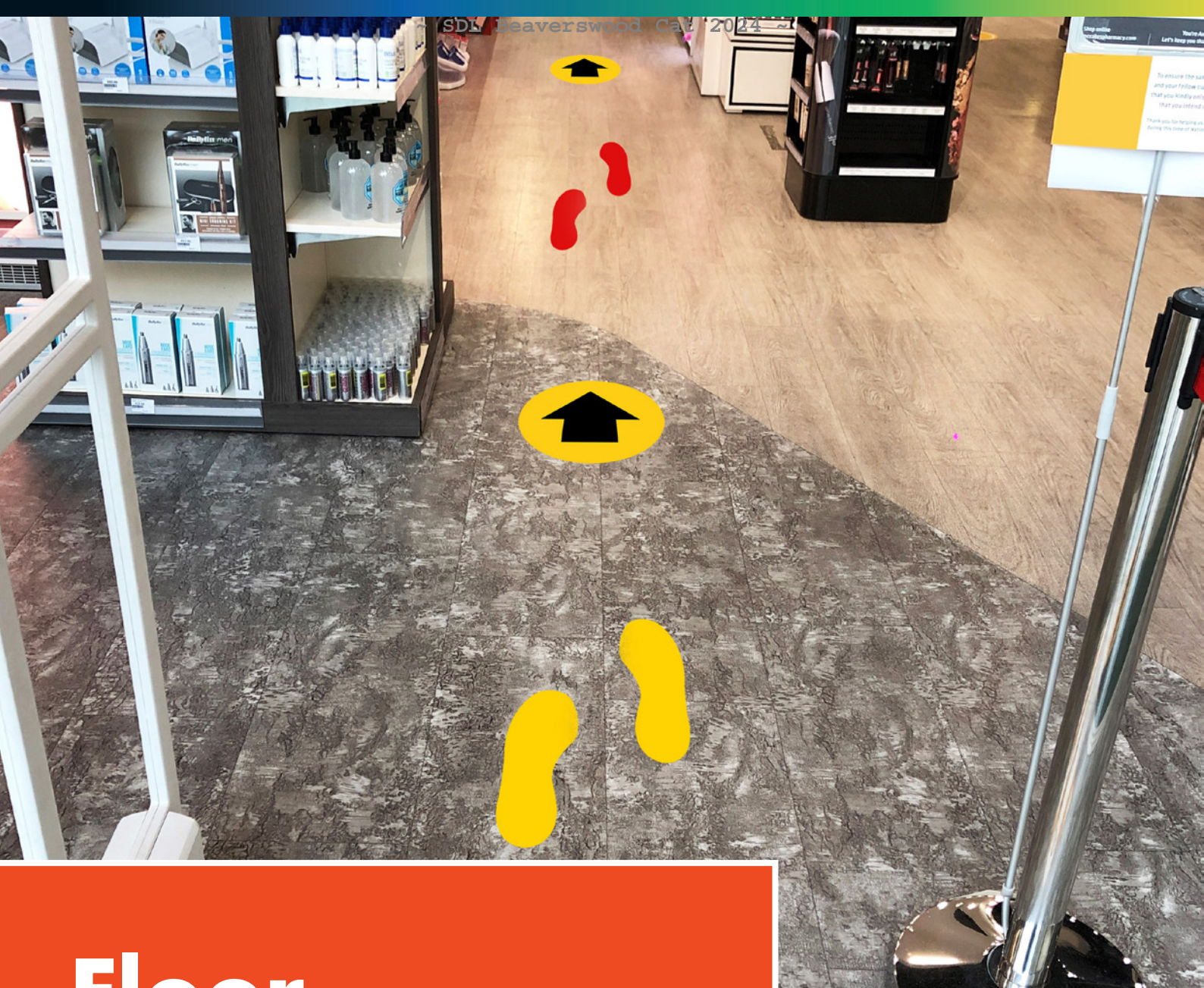

Floor Marking

We offer a wide range of floor markers and signs to meet your business needs. Floor markings have multiple purposes, from highlighting warnings or special requirements to identifying aisles and bays – plus much more. Though originally designed for warehouse use, our floor markers have rocketed in popularity in other work environments such as offices, schools, shops, hotels, or any other location where you might need to direct footfall or highlight hazards.

We can also design and manufacture bespoke floor signs and markers – simply get in touch!



Bespoke Floor Markers

Self-adhesive



- ➔ High visibility floor location labels
- ➔ Floor markers that are designed totally to your specification
- ➔ Tough and durable - made to withstand traffic in the workplace

Our high visibility floor location labels are suitable to identify specific areas of the warehouse or factory floor. The labels can be totally customised for identification of pallet positions, item numbers or packing and quarantine areas, etc.

Printed to your design, the labels have an aggressive self-adhesive backing to withstand the everyday traffic in the workplace.



Certain bespoke markers may be supplied with an additional clear non-slip overlamine to be applied over the graphic, for added print protection



Label specific areas in the workplace

To obtain a price, simply provide us with the following information:

- ➔ Size
- ➔ Text
- ➔ Colour
- ➔ Quantity
- ➔ Barcodes or Graphic Details

Floor Signals

- ➔ A simple and effective solution for marking areas on the floor
- ➔ Tough PVC with an aggressive adhesive
- ➔ Capable of withstanding everyday traffic of a fully operational warehouse
- ➔ 6 colours and 6 shape options
- ➔ Apply to a clean, flat, sealed surface



An effective solution for marking floor areas, these markers highlight walkways, traffic flow, pallet positions, and more.

Manufactured using a thin plastic membrane and laminated with an aggressive adhesive, these floor signals bond strongly to the floor and are designed to withstand everyday abrasion from forklifts to footfall and pallets. They are suitable for application onto clean, flat, sealed surfaces.

The use of different shapes and colours helps to designate different areas within the workplace and organise floor materials and flow of traffic. Clear delineation will improve product flow, ensuring everything is in the right place at the right time.

Ideal for use in 5S and Lean manufacturing areas.

Dimensions in mm:

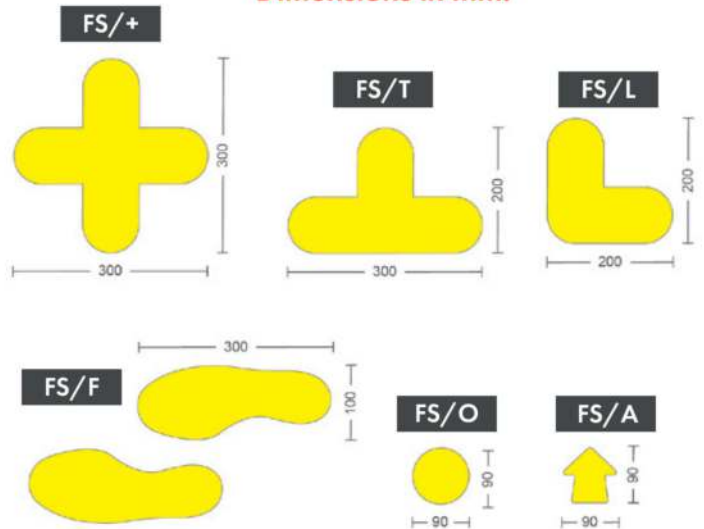

We Recommend!



See page 52 for frames4floors®



FLOOR MARKING



We recommend a minimum clearance of 50mm



Helps to improve efficiency and safety in the workplace



Self-adhesive

Available in Lean Manufacturing Colours



+ For centre pallet positions
Supplied in packs of 10 or 50

T For walkways
Supplied in packs of 100

T For between pallets
Supplied in packs of 10 or 50

↑ To indicate direction of traffic flow or position
Supplied in packs of 100

L Corner for marking out block stack pallet areas
Supplied in packs of 10 or 50

↓ For walkways or traffic flow
Supplied in packs of 10 (5 left, 5 right) or 50 (25 left, 25 right)

Floor Signals

Ref	Size (h x w)	Pack	Colour
FS/+	300mm x 300mm	10	All Colours
FS+/50		50	All Colours
FS/T	200mm x 300mm	10	All Colours
FST/50		50	All Colours
FS/L	200mm x 200mm	10	All Colours
FSL/50		50	All Colours
FS/O	90mm Diameter	100	All Colours
FS/A	90mm x 90mm	100	All Colours
FS/F	300mm x 100mm	10 5 left /5 right	All Colours
FSF/50		50 25 left /25 right	All Colours

➔ Please state colour required when ordering - (/B) Blue, (/BK) Black, (/G) Green, (/R) Red, (/Y) Yellow and (/W) White.

➔ Yellow supplied as standard unless specified.



- ➔ Flat, colour coded floor identification frames
- ➔ Available in 2 insert sizes: A4 and DL
- ➔ Choice of 6 stand out colours
- ➔ Permanent industrial strength adhesive to withstand warehouse traffic
- ➔ Ideal for identifying bulk stack locations or to highlight important information



frames4floors® are tough, colour edged PVC frames with a permanent self-adhesive backing. They enable a printed message or code to be placed and protected onto the floor.

Manufactured using a thin plastic membrane, the frames bond onto the floor surface and are therefore resistant to the rigours of a busy workplace.

The frames are available with two window sizes: A4 (up to 200 x 290mm) or DL (up to 89 x 199mm).

Frames are available with six colour options, making them ideal for 5S and Lean environments.



To fit an A4 size message:

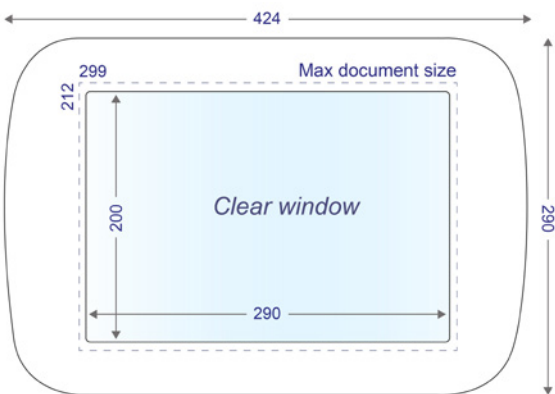

To fit a DL size message:

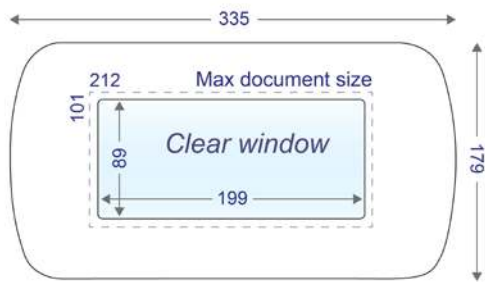

Dimensions shown in mm

A4 frames4floors®

Ref	Size of Insert (h x w)	Colour	Pack
FF4B/10	200mm x 290mm	Blue	10
FF4BK/10	200mm x 290mm	Black	10
FF4G/10	200mm x 290mm	Green	10
FF4R/10	200mm x 290mm	Red	10
FF4Y/10	200mm x 290mm	Yellow	10
FF4MIX/10	200mm x 290mm	Mixed	10
FF4BY/10	200mm x 290mm	Black/Yellow	10

➔ Mixed pack includes 2 of each of the above, not including Chevron Black/Yellow variation.

DL frames4floors®

Ref	Size of Insert (h x w)	Colour	Pack
FFDLB/10	89mm x 199mm	Blue	10
FFDLBK/10	89mm x 199mm	Black	10
FFDLG/10	89mm x 199mm	Green	10
FFDLR/10	89mm x 199mm	Red	10
FFDLY/10	89mm x 199mm	Yellow	10
FFDLMIX/10	89mm x 199mm	Mixed	10
FFDLBY/10	89mm x 199mm	Black/Yellow	10

➔ Mixed pack includes 2 of each of the above, not including Chevron Black/Yellow variation.

FLOOR MARKING



Choice of 5 standard colours or chevron:



Self-adhesive



Once in place this frame will provide a colour coded window under which data is protected, as well as allowing for quick and easy barcode scanning.

Although designed for use on the floor, these frames can also be used on walls, doors or anywhere you wish to convey your message.

Suitable for use on clean, dry, flat sealed surfaces.



We Recommend!

See page 50 for Floor Signals



Floor Graphic Markers Text and Non-Text

- ➔ High visibility floor signs with text and symbol only designs
- ➔ Large 430mm diameter
- ➔ Choose from a range of 36 designs
- ➔ Highlights warnings or special requirements
- ➔ Slip-resistance tested to R10 standard
- ➔ Bespoke prints are available



Aggressive adhesive fixing withstands the busiest of environments



Safety signs for the floor or wall

Need to get that important safety message across without going to the extreme of painting your warehouse floor? Look no further than the Beaverswood® range of eye-catching, highly visible floor markers!

Printed on the underside of a tough, clear plastic film and laminated with an aggressive adhesive, these signs can withstand the wear and tear of busy industrial environments.

Available from stock with 36 standard designs, including symbol-only designs which can be easily and instantly recognised worldwide.

Although originally designed for use on the floor, these markers can also be used on walls or other surfaces provided they're dry, clean, flat, and sealed.



Clear visual signage helps improve safety



Self-adhesive

FLOOR MARKING

Available in a range of 23 text designs
and 13 non-text designs



Graphic floor markers are 430mm in diameter

Actual Size

Specials available upon request

If you don't see a design suitable for your requirements, we can manufacture to your own design.

Simply contact the sales office.

Floor Graphic Markers

Ref	Size (Diameter)
FM01 - FM39	430mm

➔ When ordering please specify design code listed under each image.

Floor Graphic Markers Half Circles

- ➔ Large 750mm wide x 375mm deep floor markers
- ➔ Ultra-low, 0.45mm thickness helps prevent pallets from catching the edge
- ➔ Super strong adhesive quality - suitable for use in busy workplace environments
- ➔ Slip-resistance tested to R9 standard
- ➔ Highlights the area to keep clear in front of fire doors to ensure safety
- ➔ Bespoke prints are available



These large anti-slip floor markers can be used on any flat, sealed surface. Ideal for use in front of fire exit doors, to highlight fire extinguisher areas or to warn/highlight any important messaging.

The slimline markers feature an aggressive, permanent adhesive suitable for busy industrial environments - offering quick and easy installation compared to traditional marking methods - whilst remaining extremely wear resistant.

These markers can also be used underneath our racksack® range or other bins, to highlight waste recycling areas. Being 750mm wide, they will fit between most commercial pedestrian doors, and inbetween end frames at the end of each aisle.

Available in 12 text designs and 8 non-text designs, all in an anti-slip laminate tested to R9 standard.



FLOOR MARKING

Available in a range of 12 text designs and 8 non-text designs



FHMC01



FHMC02



FHMC03



FHMC04



FHMC05



FHMC06



FHMC07



FHMC08



FHMC09



FHMC10



FHMC11



FHMC12



FHMC13



FHMC14



FHMC15



FHMC16



FHMC17



FHMC18



FHMC19



FHMC20



Specials available upon request

If you don't see a design suitable for your requirements, or you require a higher anti-slip standard, we can manufacture to your own design.

Simply contact the sales office.

Half Circle Floor Graphic Markers

Ref	Size (Diameter)
FHMC01 - FHMC20	750mm Wide Half Circle Markers

➔ When ordering please specify design code listed under each image.

Floor Identification Markers



Letters A - Z

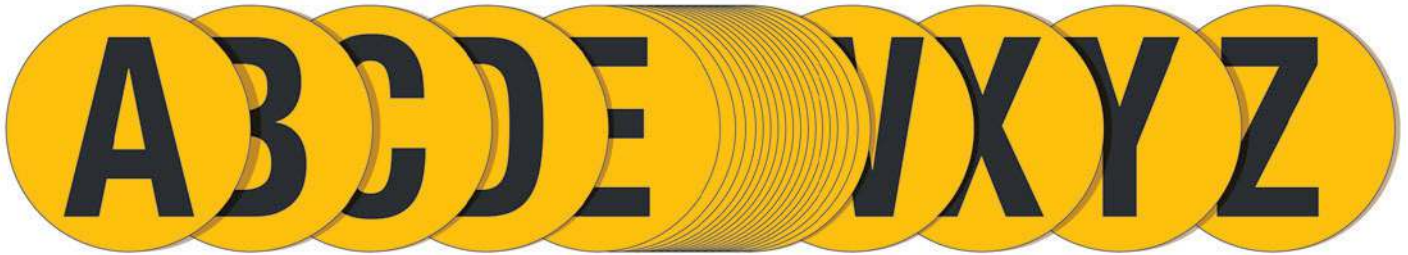

Numbers 0 - 10



- ➔ High visibility floor markers
- ➔ Designed to identify aisle, bay or other warehouse floor areas
- ➔ Available in A-Z and 0-10
- ➔ Slip-resistance tested to R10 standard
- ➔ Each marker is 190mm diameter

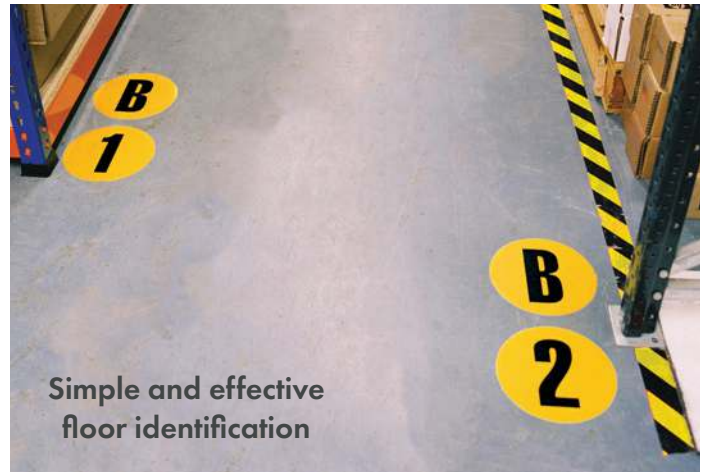

These high visibility floor markers have been designed to cope with the daily stress and strain of a modern warehouse. All our markers incorporate a permanent aggressive adhesive backing and can be used not just on the floor but any dry, clean flat sealed surface.

The 190mm diameter markers are printed with a bold black digit on a yellow background in letters A-Z or numbers 0-10.

Floor Identification Markers

Ref	Size (Diameter)	Colour
FMC/- (State Digit)	190mm	Black on Yellow



Floor Marking Tape 50mm Wide

Self-adhesive



- ➔ Tough, durable self-adhesive tapes
- ➔ Highlights hazards or restricted areas
- ➔ Easy to use applicator also available

Our range of lane marking tapes can be used to mark stairways, colour code walkways, workstations or storage areas within stores and warehouses.

Available in a range of chevron styles with general uses:



Black/Yellow

Highlights general hazard areas and obstacles



Green/White

Highlights medical stores/safety equipment



Red/White

Highlights fire protection equipment



Available in 5 standard colours and 3 chevron styles

Ref	Size (h x w)	Colour	Pack
LMT/B	50mm x 33M	Blue	1
LMT/G	50mm x 33M	Green	1
LMT/R	50mm x 33M	Red	1
LMT/W	50mm x 33M	White	1
LMT/Y	50mm x 33M	Yellow	1
LMT/BY	50mm x 33M	Black/Yellow	1
LMT/GW	50mm x 33M	Green/White	1
LMT/RW	50mm x 33M	Red/White	1

Floor Marking Tape 75mm Wide

- ➔ Extra wide - 75mm rolls
- ➔ High visibility demarcation

Manufactured using the same exacting standards as the 50mm wide version, this extra wide lane marking tape will help delineate walkways and other areas within the workplace.



Ref	Size (h x w)	Colour	Pack
LMT75/G	75mm x 33M	Green	1
LMT75/R	75mm x 33M	Red	1
LMT75/W	75mm x 33M	White	1
LMT75/Y	75mm x 33M	Yellow	1

Lane Marking Applicator

- ➔ Quicker and easier to apply tapes without the need to bend down
- ➔ Ensures accurate and quick delineation of areas
- ➔ Accepts tapes up to 100mm wide



Ref	Description
FTA1	Tape Applicator

Anti-slip Tapes

Our anti-slip flooring products are impregnated with diamond hard aluminium oxide, making them tough, durable and long lasting

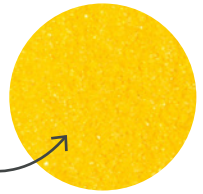

Available in 4 widths and 3 colours



► Please state colour required when ordering.

- Quick and easy to apply anti-slip tape
- Tough, durable and long lasting
- Available in various widths and colours to suit your needs
- Supplied in 18.3M rolls



Our anti-slip tapes are manufactured through a unique process ensuring it's one of the most effective anti-slip surfaces available.

Our tapes are impregnated with diamond hard aluminium oxide making it hardy, tough, durable and long lasting.

The backing has a heavy coating of permanent pressure sensitive adhesive which is water resistant and ensures once it's down, it stays down.



Ref	Size (h x w)	Colour
AST25	25mm x 18.3M	Black, Yellow, Black/Yellow
AST50	50mm x 18.3M	Black, Yellow, Black/Yellow
AST100	100mm x 18.3M	Black, Yellow, Black/Yellow
AST150	150mm x 18.3M	Black, Yellow, Black/Yellow

Special Tapes and Plates

As well as our standard anti-slip tapes, we produce bolt down plates, conformable tapes, glow in the dark tapes, reflective tapes and many more.

Bolt Down Plates - Great for wet environments and wooden steps or decking. These weatherproof plates are available in different plate sizes.

Conformable - Ideal to cover chequer plate/diamond tread/durbar plate surfaces.

Glow in the Dark Tapes - Ensure walkways, stairways, entrances and exits are illuminated well enough for you to find an exit in the event of a power cut or emergency.



Reflective Tapes - Simple, self-adhesive, high visibility safety tape, suitable for marking hazardous or dangerous areas, such as: vital routes, staircases, ledges, and low hanging objects like racking beams.

Anti-slip Feet

Self-adhesive





- ➔ Anti-slip footprints for marking out safe pedestrian routes
- ➔ Industrial strength adhesive and anti-slip properties
- ➔ Supplied in packs of 10: 5 right and 5 left
- ➔ 2 different designs to choose from

Our anti-slip feet are ideal for creating marked pedestrian routes and also have the advantage of making a terrific anti-slip surface.

Available in 2 designs: standard footprint and large footprint with toes. These are ideal for environments such as schools, hospitals, shops, and warehouses.



Ref	Description	Size (h x w)	Colour
ASF/BK	Standard Foot 	240mm x 90mm	Black
ASF/CL		240mm x 90mm	Clear
ASF/YE		240mm x 90mm	Yellow
ASF/YB		240mm x 90mm	Black/Yellow
ASFTL/BK	Foot with Toes 	210mm x 120mm	Black
ASFTL/YE		210mm x 120mm	Yellow

Anti-slip Stair Treads

- ➔ Available in plain black
- ➔ Supplied in packs of 5
- ➔ Ideally suited for use on stair treads
- ➔ Bespoke options also available

Our anti-slip treads are manufactured using the same high standard as our anti-slip tape and are ideally suited for use on stair treads.

Available in plain black, however, we can offer your own message to be printed, please enquire for further details.



Ref	Size (h x w)	Colour	Pack
AST	150mm x 610mm	Black	5

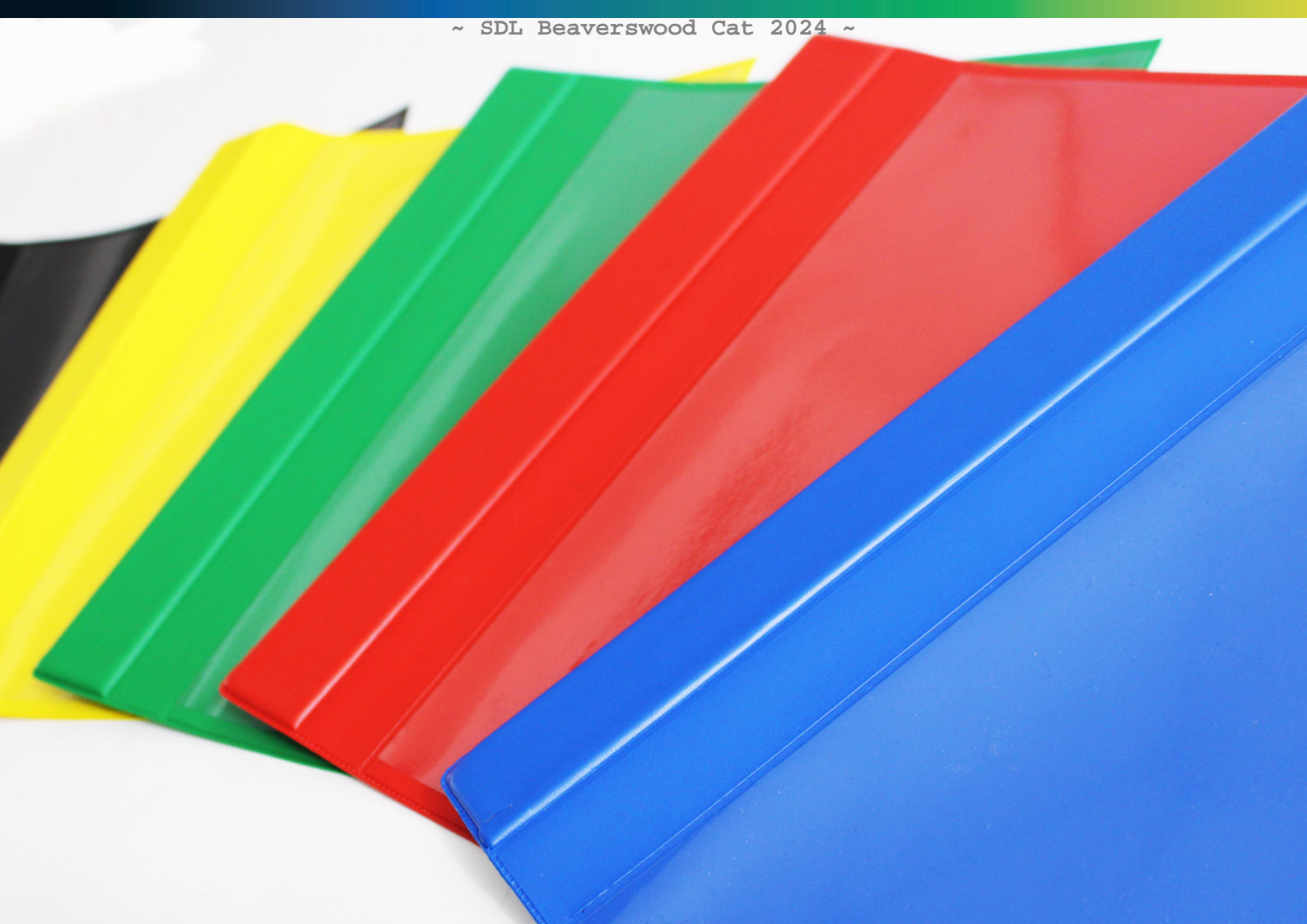

Document Display

Our document display solutions are ideal for displaying prominent information due to their colourful frames, different sizes, and ability to adhere to most sealed surfaces with their strong self-adhesive backing.

For added flexibility, our range also includes magnetic document pockets which can be lifted and relocated when needed.

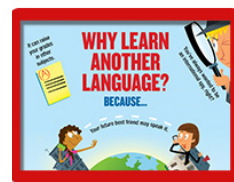

Clear Document Pockets Industrial Strength

- ➔ Industrial quality document pockets with strong welded edges
- ➔ Keeps documentation neat and clean
- ➔ Available in 4 fixings - magnetic, self-adhesive, clip-on and tie-on
- ➔ Vertical and horizontal formats

A range of document pockets to suit most environments, with magnetic or self-adhesive fixings. Also available as clip-on and tie-on to suit wire bins and cages.

The adhesive pockets are supplied with an aggressive adhesive tape along the top and bottom edge (A7 pocket has tape along the top edge only) for a permanent fixing.

The magnetic pockets are supplied with a magnetic strip along the top, so they can be simply lifted and relocated when necessary.

Tie-on pockets can secure around a maximum diameter of 60mm, whilst clip-on pockets are ideal for use on wire bins and cages.



It's the fine details that make a difference, which is why our pockets have industrial strength welded edges and rounded corners to improve their durability

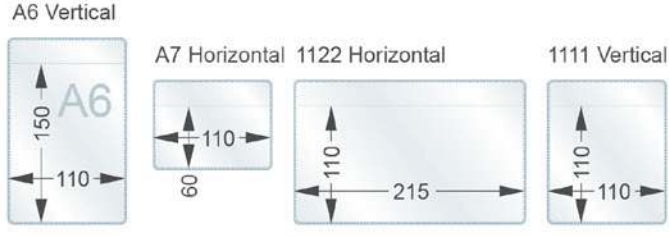
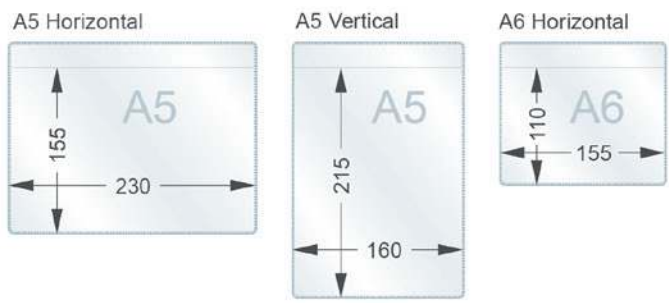
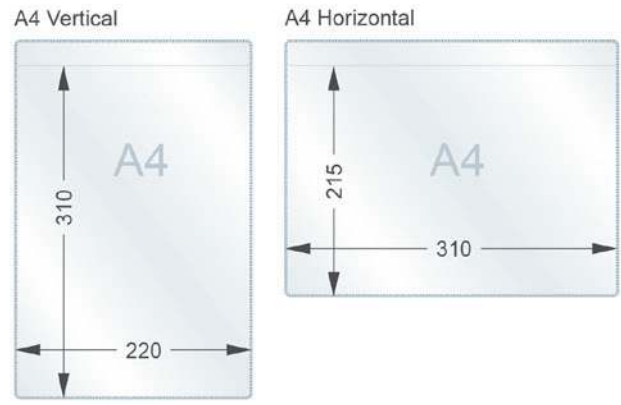
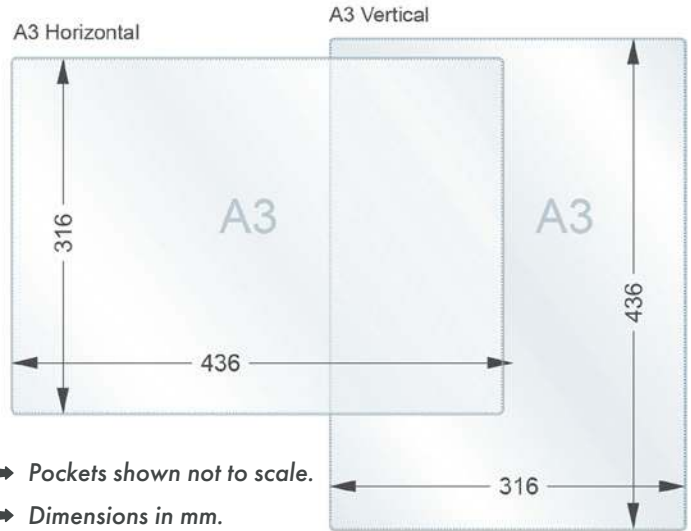

The A7 size can also be used as visitor badge pockets



Magnetic fixing - Ideal for relocating on steel surfaces

VWR Cat No	Item Description	Mfg Cat	UC
SC67100-870	RESPIRATOR N95	8000	EA
TXE190GPNWU	ETHANOL 190 PROOF 1GL	E190GP	EA
TXE200FPNWU	ETHYL ALC 200PRF 5GL PLASTIC	E200FP	EA
TXE200PPNWU	ETHANOL 200 PROOF 1PT	E200PP	EA
TXSCE200GPNWU	ETHYL ALC 200PRF 1GL EACH	E200GP	EA
HP-5182-0714	SCREW CAP VIALS CLEAR PK100	5182-0714	PK
HP-5182-0717	SCREW CAPS BLUE PK100	5182-0717	PK
21835-032	ALCONOX DETERGENT 4LB	1104	EA
21837-005	LIQUI-NOX DETERGENT 1QT	1232	EA
SC47729-228	YELLOW	MS-01KT4-8	
SC47730-744	VWR FACESHIELD VELCROBND	2802	
55411-050	VWR RAZOR BLADES #9 PK100	94-0374	
52877-150	PK10	1300-20-VWC	PK
SC52877-310	PK10	1400-20-VWC	EA
80094-530	BAG 4ML YELLOW 18X24 CS250	71-6-30Y	CS
80094-532	CS75	47-6-35B	CS
80094-534	NYLON TIES F/BLK BAGS PK1000	84-1-02	PK
10011-270	ASS PK5	R-60-A	PK
10011-680	TUBE MICRO .6ML CLR PK1000	MCT-060-C	PK
10011-700	PK500	MCT-150-C	PK
10011-722	TUBE MICRO 1.7ML CLR PK500	MCT-175-C	PK
10011-742	PK500	MCT-200-C	PK
10011-764	PK125	PCR-0208-C	PK
10011-786	TUBE CAP 8STRIP CLEAR PK125	PCR-02CP-C	PK
47749-868	PK960	TXLF-10-LRS	PK
TXHWM128N-110	BOTTLE PLASTIC W/CAP 1GAL	HWM128N-110	EA
TXHWM32N-89	BOTTLE PLASTIC W/CAP QUART	HWM32N-89	EA
TXN2100PW	LID 5GAL	N2100PW	EA
TXNP2150W-CD	PAIL 5GAL	NP2150W-CD	EA
90003-108	100GM	239210	EA
BD305143	PK100	305143	PK
BD305187	NEEDLE DISP 19G 1.5IN PK100	305187	PK
BD309586	SYRINGE LUER SLIP PK100	309586	PK
BD309602	PK100	309602	PK
SC21008-918	PK50	352097	PK
SC21008-929	TUBE CENT BLUMAX 15ML PK50	352099	PK
SC21008-936	CENTRIFUGE TUBE 15ML PK50	352096	PK
SC21008-938	50ML	352073	PK
SC21008-940	PK25	352070	PK
SC21008-951	PK25	352098	PK
SC25373-100	DISH PETRI 100X15MM PK20	351029	PK
SC25382-064	TISSUE DISH 35X10 MM PK20	353001	PK
SC-25382166	PK20	353003	PK
SC-25382-188	DISH EASY GRIP 60X15MM PK20	353004	PK
SC25383-103	BG/10	353025	BG
SC29185-302	FLASK TC CN 25CM2 70ML PK20	353109	PK
SC29185-308	FLASK TC SN 175CM2 750ML PK5	353112	PK
SC53106-195	PIPET SER EXT INDIV PK50 25ML	357535	PK
SC53300-283	PIPET SERO PS 1X.01ML PK100	357521	PK
SC53300-421	PIPET SERO 5X1/10 ML PK50	357543	PK
SC53300-523	PK50	357551	PK
SC60819-524	PK25	352057	PK
SC60819-728	CULTURE TUBE RB POLYP 5ML	352063	PK
SC60819-761	PK25	352059	PK

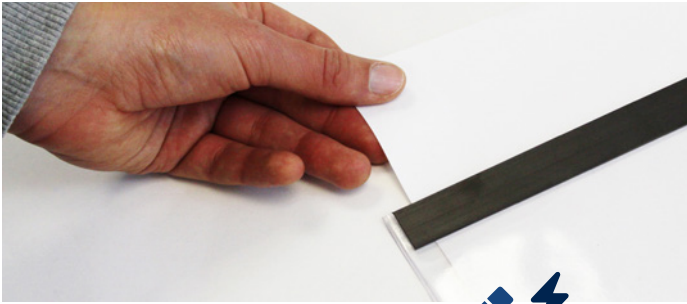

Magnetic Document Pockets

Ref	Size (h x w)	Suits Paper Size	Pack
MP1122/10	110mm x 215mm	-	10
MP1111/10	110mm x 110mm	-	10
MP3H/10	316mm x 436mm	A3	10
MP3V/10	436mm x 316mm	A3	10
MP4H/10	215mm x 310mm	A4	10
MP4H/50	215mm x 310mm	A4	50
MP4V/10	310mm x 220mm	A4	10
MP4V/50	310mm x 220mm	A4	50
MP5H/10	155mm x 230mm	A5	10
MP5H/50	155mm x 230mm	A5	50
MP5V/10	215mm x 160mm	A5	10
MP5V/50	215mm x 160mm	A5	50
MP6H/10	110mm x 155mm	A6	10
MP6H/50	110mm x 155mm	A6	50
MP6V/10	150mm x 110mm	A6	10
MP6V/50	150mm x 110mm	A6	50
MP7H/100	60mm x 110mm	A7	100



Self-adhesive Document Pockets

Ref	Size (h x w)	Suits Paper Size	Pack
AP1122/10	110mm x 215mm	-	10
AP1111/10	110mm x 110mm	-	10
AP3H/10	316mm x 436mm	A3	10
AP3V/10	436mm x 316mm	A3	10
AP4H/10	215mm x 310mm	A4	10
AP4H/50	215mm x 310mm	A4	50
AP4V/10	310mm x 220mm	A4	10
AP4V/50	310mm x 220mm	A4	50
AP5H/10	155mm x 230mm	A5	10
AP5H/50	155mm x 230mm	A5	50
AP5V/10	215mm x 160mm	A5	10
AP5V/50	215mm x 160mm	A5	50
AP6H/10	110mm x 155mm	A6	10
AP6H/50	110mm x 155mm	A6	50
AP6V/10	150mm x 110mm	A6	10
AP6V/50	150mm x 110mm	A6	50
AP7H/100	60mm x 110mm	A7	100

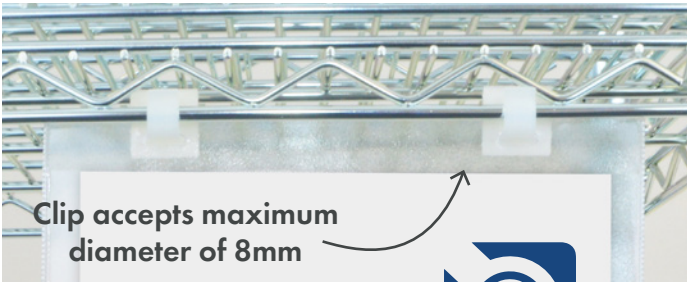

Clip-On Document Pockets Supplied with Clips

Ref	Size (h x w)	Suits Paper Size	Pack
CP1122/10	110mm x 215mm	-	10
CP1111/10	110mm x 110mm	-	10
CP4H/10	215mm x 310mm	A4	10
CP4H/50	215mm x 310mm	A4	50
CP4V/10	310mm x 220mm	A4	10
CP4V/50	310mm x 220mm	A4	50
CP5H/10	155mm x 230mm	A5	10
CP5H/50	155mm x 230mm	A5	50
CP5V/10	215mm x 160mm	A5	10
CP5V/50	215mm x 160mm	A5	50
CP6H/10	110mm x 155mm	A6	10
CP6V/10	150mm x 110mm	A6	10
CP7H/100	60mm x 110mm	A7	100

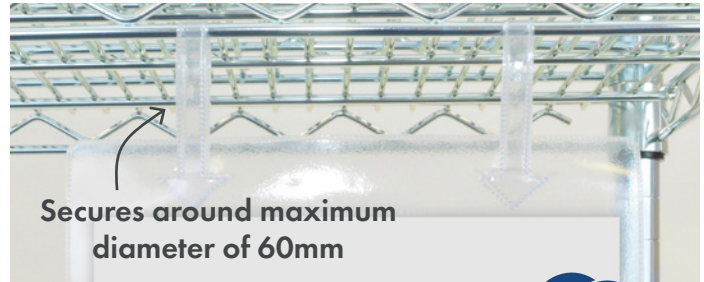

Tie-On Document Pockets Supplied with Arrow Tag Fixings

Ref	Size (h x w)	Suits Paper Size	Pack
TP1122/10	110mm x 215mm	-	10
TP1111/10	110mm x 110mm	-	10
TP4H/10	215mm x 310mm	A4	10
TP4H/50	215mm x 310mm	A4	50
TP4V/10	310mm x 220mm	A4	10
TP4V/50	310mm x 220mm	A4	50
TP5H/10	155mm x 230mm	A5	10
TP5H/50	155mm x 230mm	A5	50
TP5V/10	215mm x 160mm	A5	10
TP5V/50	215mm x 160mm	A5	50
TP6H/10	110mm x 155mm	A6	10
TP6V/10	150mm x 110mm	A6	10
TP7H/100	60mm x 110mm	A7	100

Rainbow Pockets

- ➔ Industrial strength coloured document pockets
- ➔ Turn your noticeboard into a colourful information centre
- ➔ Available in 2 sizes, 3 fixings and 5 stand out colours
- ➔ A4 and A5 pockets are available in vertical and horizontal formats
- ➔ Supplied in packs of 10

Make your important documentation stand out with these coloured document pockets. The pockets, which are available in 5 colours, will help to transform plain noticeboards into a bright and bold information centre perfect for 5S and Lean management systems.

These coloured document pockets are ideal in the office, warehouse or anywhere in the workplace.

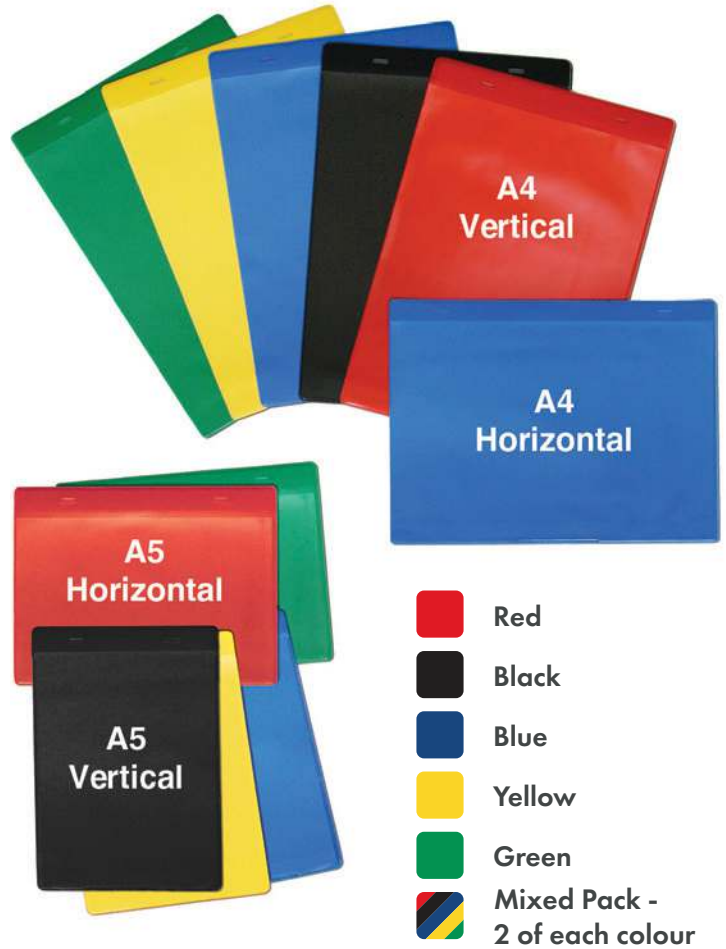

Magnetic Coloured Pockets



Suits steel surfaces

- ➔ Ideal for steel cupboards, magnetic boards and other steel surfaces
- ➔ Quick and easy to move
- ➔ Magnetic fixings are also suitable for cold stores

Ref	Size (h x w)	Pack
CMP4H	215mm x 310mm (A4 horizontal)	10
CMP4V	310mm x 220mm (A4 vertical)	10
CMP5H	155mm x 230mm (A5 horizontal)	10
CMP5V	215mm x 160mm (A5 vertical)	10

Self-adhesive Coloured Pockets



Permanent fixing

- ➔ Aggressive adhesive offers a permanent fixing solution
- ➔ Adhesive tape at top and bottom edge
- ➔ Will adhere to most non-porous surfaces such as plastic and metal

Ref	Size (h x w)	Pack
CAP4H	215mm x 310mm (A4 horizontal)	10
CAP4V	310mm x 220mm (A4 vertical)	10
CAP5H	155mm x 230mm (A5 horizontal)	10
CAP5V	215mm x 160mm (A5 vertical)	10



Magnetic pockets are ideal for steel office cabinets

Tie-on Coloured Pockets



Ideal for roll cages

- ➔ Tie-on straps can secure around a maximum diameter of 60mm
- ➔ Ideal for use on picking trolley handles and roll containers
- ➔ Can be used in 2 or 4 ring binders

Ref	Size (h x w)	Pack
CTP4H	215mm x 310mm (A4 horizontal)	10
CTP4V	310mm x 220mm (A4 vertical)	10
CTP5H	155mm x 230mm (A5 horizontal)	10
CTP5V	215mm x 160mm (A5 vertical)	10



➔ Please state colour required when ordering - (/B) Blue, (/BK) Black, (/G) Green, (/R) Red, (/Y) Yellow and (/X) Mix.

Magnetic Wrap-around Pockets

- ➔ Designed for industrial roll cages or mesh containers
- ➔ Available in sizes - A4, A5 and A6
- ➔ Manufactured from tough plastic
- ➔ Front flap to protect contents
- ➔ Longer headers suit trolley handles
- ➔ Available in packs of 10 or 50

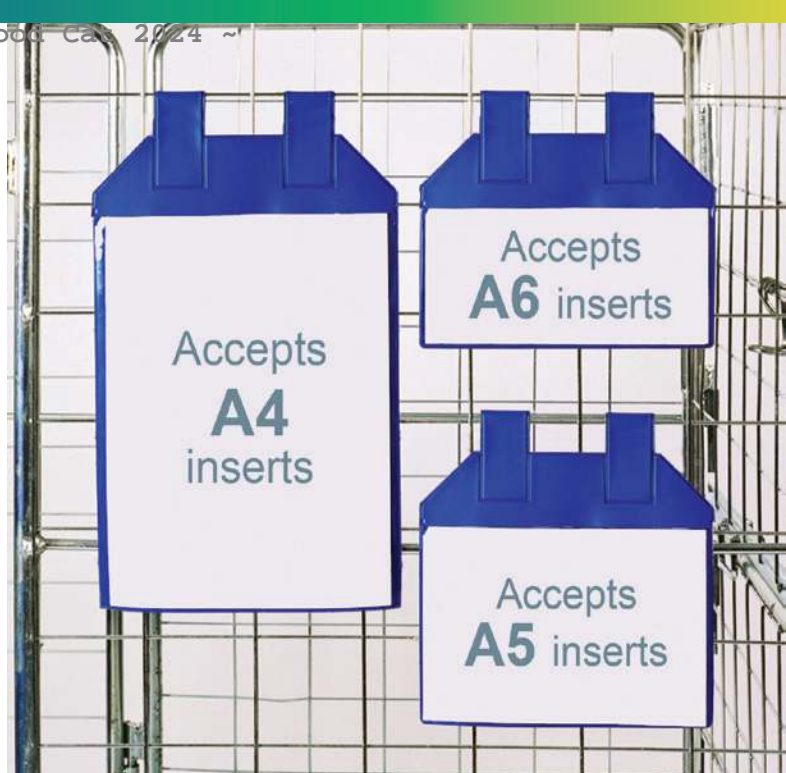

Three hard wearing information pockets in sizes A4, A5 and A6. Each pocket has a unique looped magnetic header that is designed to wrap around the mesh of a cage.

A special flap shields the opening of each pocket providing your document with protection.

The clear PVC face enables the message to be clearly seen without the need to remove the document.

Magnetic Wrap-around Pockets

Ref	Size (h x w)	Pack
WRP4V/10	297mm x 210mm	10
WRP5H/10	148mm x 210mm	10
WRP6H/10	105mm x 210mm	10
WRP4V/50	297mm x 210mm	50
WRP5H/50	148mm x 210mm	50
WRP6H/50	105mm x 210mm	50



Hanging Pockets

- ➔ Information pockets manufactured in tough plastic
- ➔ Unique hooked header design
- ➔ Hang onto crates, trolleys and more
- ➔ Two sizes available - A4 or A5
- ➔ Available from stock
- ➔ Available in packs of 10 or 100

Our premium hanging pockets feature a unique hooked header, designed to hang and grip onto the edge of an industrial wooden case or plastic crate.

This pocket offers a dual function, to either store documents linked to the case or to provide identification where a conventional label will not adhere to a wooden or textured surface.

The hanging pocket is also suitable for trolleys, stillages, pallet converters and many more items that have a hanging rail of up to 25mm maximum thickness.



Ideal for non-metallic situations



Clear identification for crates

Hanging Pockets

Ref	Size (h x w)	Pack
WCP4H/10	326mm x 315mm	10
WCP5H/10	163mm x 234mm	10
WCP4H/100	326mm x 315mm	100
WCP5H/100	163mm x 234mm	100



Suitable for hanging onto trolleys



Ring Binders

Self-adhesive



Magnetic



- ➔ Create quick and flexible information centres
- ➔ 2 or 4 hole ring binders
- ➔ Magnetic or self-adhesive backed, offering a flexible fixing system

Keeping multiple pages of information readily available in a prominent visual position can be difficult. Fortunately, Hold-All® Ring Binders provide the solution!

These binders are ideal for storing health and safety, fire action, production planning, or any other important information.

Magnetic or self-adhesive backed, the binder offers documents a versatile fixing system for either magnetic receptive boards, steel surfaces or sealed surfaces. Use self-adhesive where heavier folders are involved.

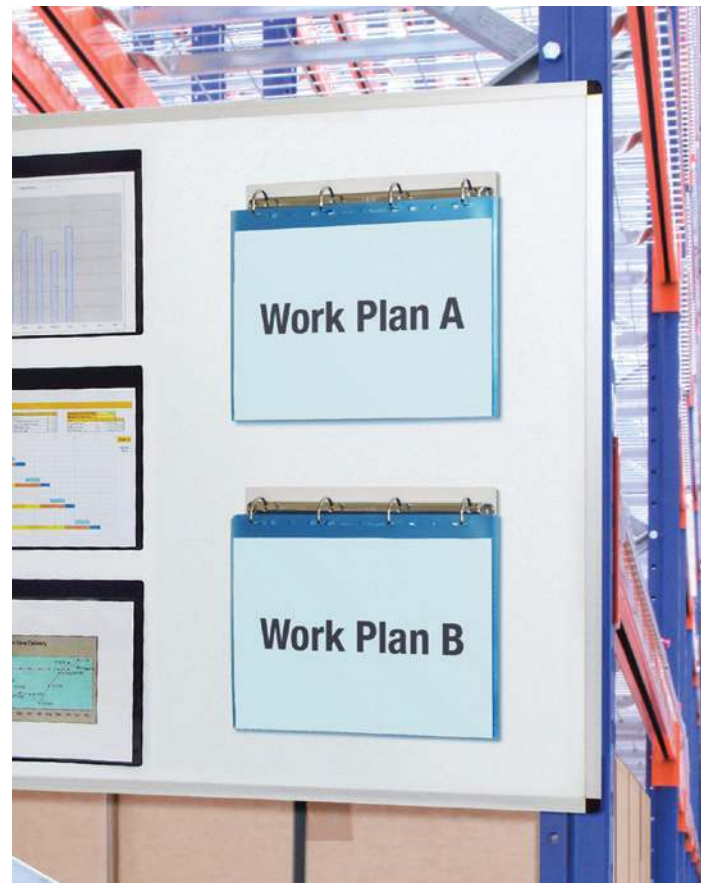

Available with 2 or 4 ring options



Hold-All® Ring Binders

Ref	Description	Fixing	Pack
RBA4/3	4 Ring Holder	Self-adhesive	3
RBA2/3	2 Ring Holder	Self-adhesive	3
RBM4/3	4 Ring Holder	Magnetic	3
RBM2/3	2 Ring Holder	Magnetic	3

➔ Please note: pockets not included.



Ring Binder PVC Covers

- ➔ Colour coded PVC Covers for Hold-All® ring binders
- ➔ Covers and protects A4 horizontal files
- ➔ Covers can be retrofitted to the ring binders

These colour coded covers work with our Hold-All® ring binders to give an attractive and highly visual finish.

The cover features a front pocket that will accommodate an A4 sheet, so you can add a title panel to the cover.

Suitable for use with Hold-All® 2 or 4 ring binders in A4 horizontal format. Available in 5 colour options and supplied in packs of 5.

Hold-All® Covers

Ref	Description	Pack
RBC/5	PVC Cover	5

➔ Please state colour required when ordering - (/B) Blue, (/BK) Black, (/G) Green, (/R) Red and (/Y) Yellow.



Available in 5 colours



Make it stand out from the crowd with a choice of 5 colours

Keep your private information hidden with a colourful PVC cover



Tough Weather Resistant Pockets

- ➔ Protect your documents outdoors with these industrial quality clear pockets
- ➔ Secure press seal fastening
- ➔ Multiple fixing options - magnetic, self-adhesive or tie-on



Industrial strength pockets designed for external use with a press seal weather resistant fastening.

The pockets have sufficient room for numerous A4 size documents, plus pens and other stationery etc.

Available in horizontal or vertical formats, these pockets have 3 fixing options. A strong magnetic fixing, allowing the pocket to be located to a ferrous steel surface, yet easily lifted off. A self-adhesive fixing for permanent locations, and a tie-on fixing that allows the pocket to be secured around a picking trolley handle or the mesh of a roll cage. This fixing allows for a maximum diameter of 60mm.

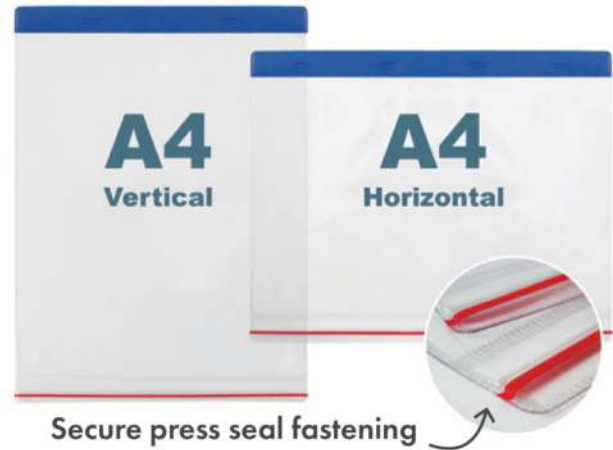

Weather Resistant Pockets

Ref	Description	Fixing	Pack
WRA4H/10	A4 Horizontal	Self-adhesive	10
WRA4H/50	A4 Horizontal	Self-adhesive	50
WRA4V/10	A4 Vertical	Self-adhesive	10
WRA4V/50	A4 Vertical	Self-adhesive	50
WRM4H/10	A4 Horizontal	Magnetic	10
WRM4H/50	A4 Horizontal	Magnetic	50
WRM4V/10	A4 Vertical	Magnetic	10
WRM4V/50	A4 Vertical	Magnetic	50
WRT4H/10	A4 Horizontal	Tie-on	10
WRT4H/50	A4 Horizontal	Tie-on	50
WRT4V/10	A4 Vertical	Tie-on	10
WRT4V/50	A4 Vertical	Tie-on	50

Magnetic

Self-adhesive

Tie-on

We Recommend!

See page 70 for our **Hold-All® Ring Binders** that work with our tie-on pockets

Health & Safety Info & Product Data Sheets

Fully Adhesive Backed Pockets



Self-adhesive

- ➔ Accepts A4, A5, A6 and A7 inserts
- ➔ Adheres to any dry smooth surface
- ➔ Clear front allows barcodes to be easily scanned
- ➔ Ideal for plastic containers, metal stillages and many other locations

A4, A5, A6 and A7 sized document pockets designed for keeping information visible in office, factory and warehouse environments.

These clear pockets also protect documents from dirt and grime. Simply peel off the backing sheet and adhere the fully adhesive pocket to any smooth, sealed surface.

Adhesive Backed Pockets

Ref	Size (h x w)	Description	Pack
AW4H/50	217mm x 302mm	A4 Horizontal	50
AW4V/50	302mm x 217mm	A4 Vertical	50
AW5H/50	158mm x 219mm	A5 Horizontal	50
AW5V/50	219mm x 158mm	A5 Vertical	50
AW6H/50	110mm x 155mm	A6 Horizontal	50
AW6V/50	155mm x 110mm	A6 Vertical	50
AW7H/50	80mm x 115mm	A7 Horizontal	50
AW7V/50	115mm x 80mm	A7 Vertical	50



Easily insert document into adhesive pocket

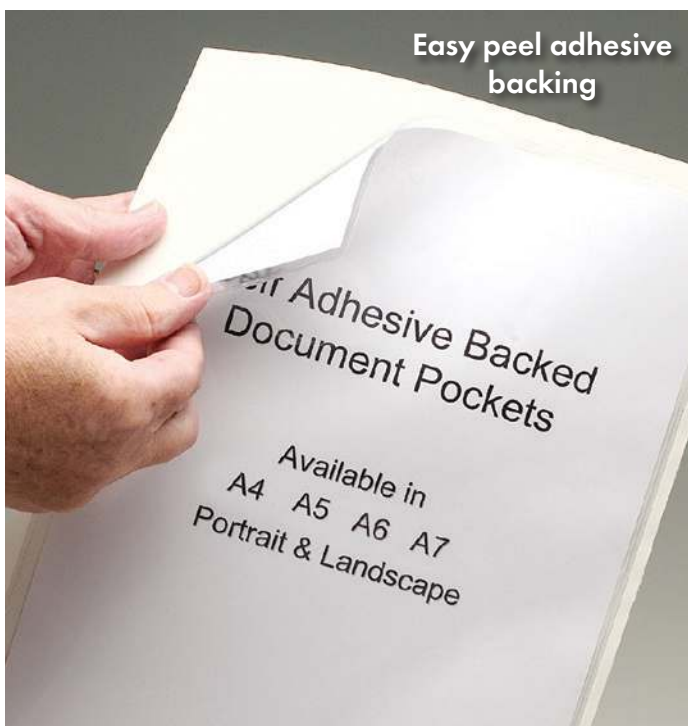



- ➔ Enables documents to be framed and displayed
- ➔ Available in sizes to fit A2, A3, A4 and A5
- ➔ Magnetic and self-adhesive fixing
- ➔ Ideal for Lean and 5S environments
- ➔ Frames can be used horizontally or vertically



frames4docs® are a range of colour coded frames designed for easy and prominent document display. They are ideal for creating information centres and to help portray important information in 5S and Lean environments. Available in a magnetic and self-adhesive fixing.

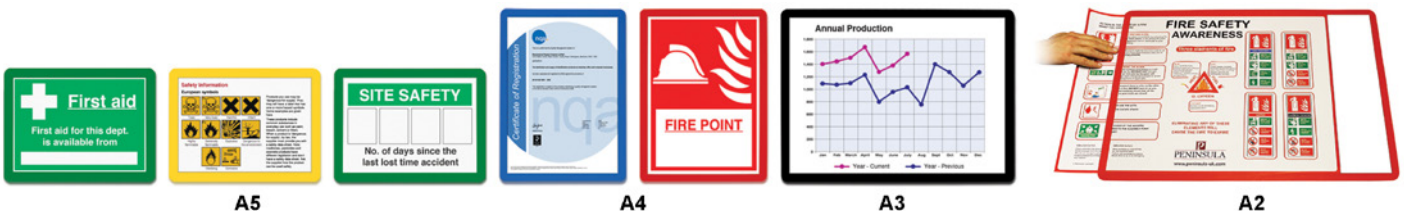
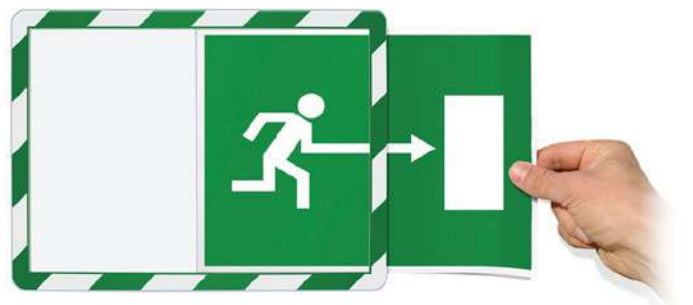
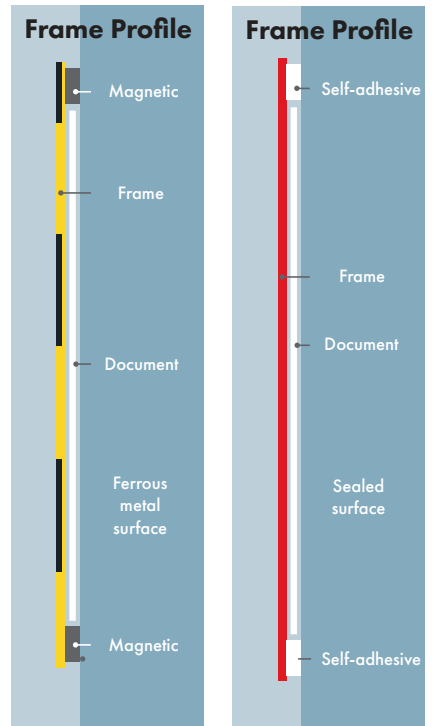
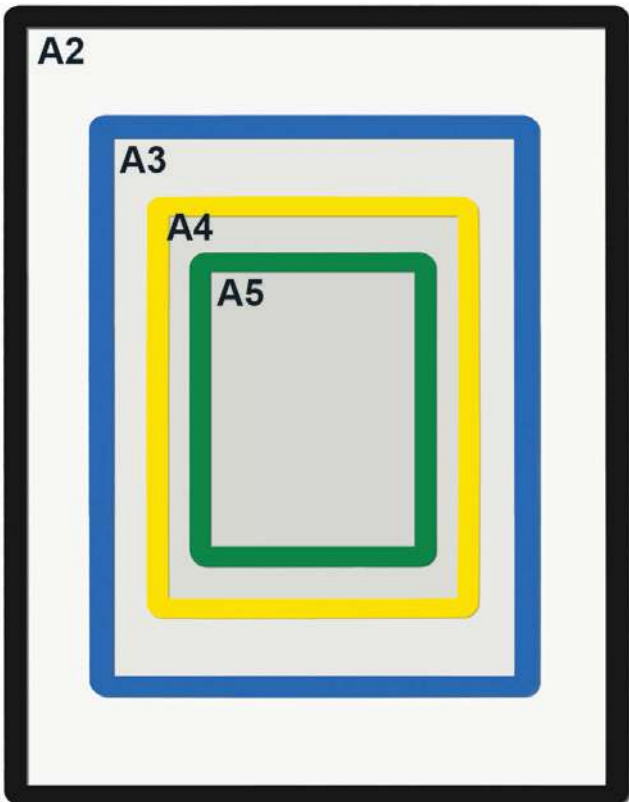

DOCUMENT DISPLAY

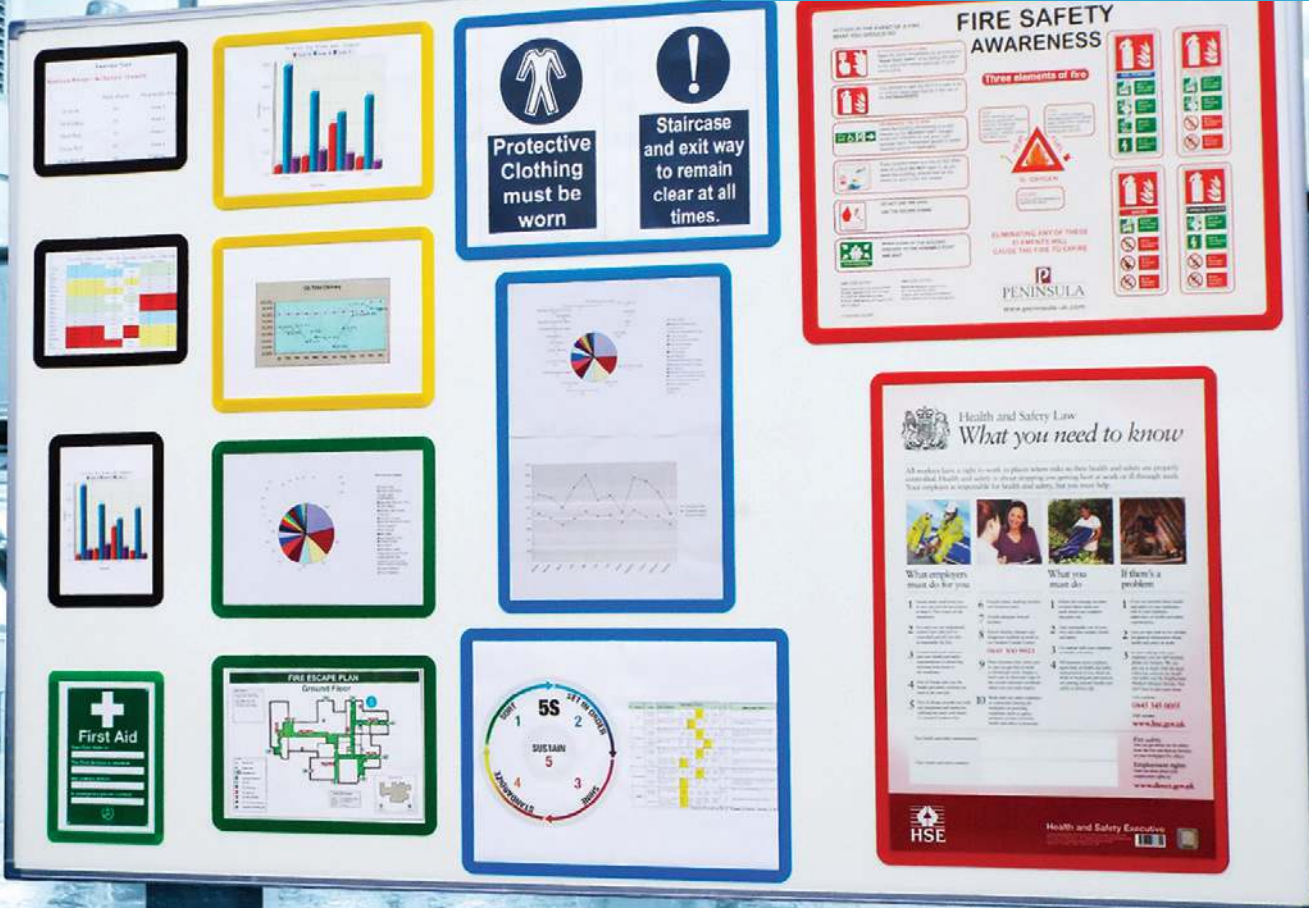

Magnetic Fixing



The magnetic frames4docs® have a very strong pull force and can be applied to almost any flat steel surface. The clever design allows for easy insertion and removal of documents without the necessity of moving the frame. However, if required, simply lift and relocate the frame with ease. The magnetic frames are suitable for use on magnetic notice boards, steel cupboards, solid racking and shelving ends, and most other metallic surfaces.



frames4docs® Self-adhesive and Magnetic

Ref	Holds Document Size	Fixing	Pack
SFD2/10	A2	Self-adhesive	10
SFD3/10	A3	Self-adhesive	10
SFD4/10	A4	Self-adhesive	10
SFD5/10	A5	Self-adhesive	10
MFD2/10	A2	Magnetic	10
MFD3/10	A3	Magnetic	10
MFD4/10	A4	Magnetic	10
MFD5/10	A5	Magnetic	10

➔ Please state colour required when ordering - (/B) Blue, (/BK) Black, (/G) Green, (/R) Red and (/Y) Yellow.

Self-adhesive Fixing



The self-adhesive frames4docs® have a permanent, aggressive adhesive which suits non-porous surfaces in the office, warehouse, and throughout the workplace. The clever design allows for documents to be easily removed and replaced when required.



frames4docs® A4 Chevron Frames

Ref	Colour	Fixing	Pack
SFD4BY/10	Black/Yellow	Self-adhesive	10
SFD4GW/10	Green/White	Self-adhesive	10
SFD4RW/10	Red/White	Self-adhesive	10
MFD4BY/10	Black/Yellow	Magnetic	10
MFD4GW/10	Green/White	Magnetic	10
MFD4RW/10	Red/White	Magnetic	10





frames4docs® Title Frame

- ➔ Customise headers to your design
- ➔ Simply slide in a new header to update your titles time and time again

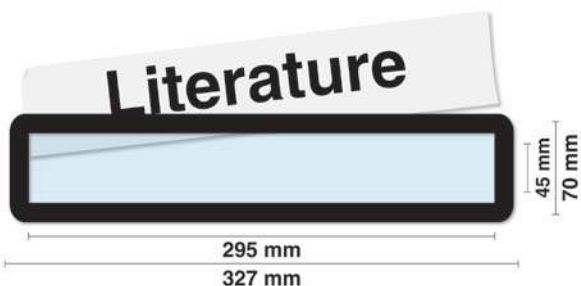

frames4docs® Title Frame

Ref	Description	Pack
SFD6BK/10	Black Title Frame	10
MFD6BK/10	Black Title Frame	10



Shadow Boards

Modulean® takes away the need (and the headache) for custom shadow boards by delivering a range of modular standard boards that are widely used across the workplace, removing a great deal of expense and time associated with custom shadow boards. They also aid in compliance with the 5S Lean system.

Modulean® Rack End Boards can be used in conjunction with many of our other products, transforming dead-space into working space!



SHADOW BOARDS

MODULEAN® LITE

Available in 4 colours



- ➔ Smaller and lighter Shadow Boards
- ➔ Keep your workplace organised on the go
- ➔ Choose from a range of standard 500mm x 500mm 5S boards
- ➔ Various colour options to keep track of tools
- ➔ Supplied with the products on display

Mix and match 500mm x 500mm Modulean® boards to create your own mobile system which is simple to move and relocate around the industrial workplace when used with the mobile frame.

The mobile framework has wheel castors with brakes and can hold two 500mm x 500mm Modulean® boards on each side, fixed with screws for a secure finish.

These smaller sized Modulean® boards can also be used on their own by being screwed onto a wall.

Our racksack® trolley can also be used as an accessory to the mobile system to help recycle and segregate waste on the go.



Use on a mobile stand or a wall

505mm

1920mm

Dry Cleaning Board

Fire Safety Board

First Aid Board

Mask and Gloves

Notice Board

Sanitising Board



Modulean® Lite

Ref	Description
SHB50/1	Dry Cleaning Board*
SHB50/2	Fire Safety Board*
SHB50/3	First Aid Board*
SHB50/4	Mask and Glove Dispenser*
SHB50/5	Notice Board*
SHB50/6	Sanitising Board*
SHBMF	Mobile Framework
T1B/1	racksack® trolley
DFM01	50 Disposable Face Masks
VGM01	100 Vinyl Gloves - Medium
HGP01	1L Alcohol Hand Gel Pouch
SHB50SW	Alcohol Free Sanitising Wipes

➔ *Please state colour required when ordering - (/B) Blue, (/G) Green, (/R) Red and (/Y) Yellow.

MODULEAN® SHADOW BOARDS

Pick and choose from a range of standard boards of 750mm x 750mm in various colour options to create a modular and lean visual communication system to suit your requirements.

5S Information Board

Notice Board

Wet Cleaning Board

XL Cleaning Board

Fire Safety Board



Magnetic Easy Wipe Board

First Aid Board

Dry Cleaning Board

Eyewash/Accident Board

- ➔ Modular system to fit any space
- ➔ Choose from a range of standard 750mm x 750mm 5S boards
- ➔ Various colour options to keep track of tools
- ➔ Customise through title frames to suit your brand
- ➔ Supplied with the products on display

A range of Modulean® Shadow Boards to keep track of your tools. These simple-to-store, simple-to-transport, simple-to-install boards are available in a standard range that covers the full spectrum of the 5S lean process - sure to fulfil any company's requirement of a shadow board.

Pick and choose from standard boards of 750mm x 750mm to create a modular and lean system to suit your requirements.

Each board is supplied with the products on display and fixings, along with a title frame which can be customised to your design. These colourful boards will be sure to stand out in the workplace.



Can be used in a range of environments within the workplace



SHADOW BOARDS



Available in 4 colours



Other designs and bespoke boards can be produced, please contact us for further details

Supplied with Title Frames



Accessories

Accessorise your boards with frames4docs®, Rainbow Pockets, and other Modulean® accessories.



Modulean® Shadow Boards

Ref	Description
SHB001	5S Information Board - White Only
SHB002	Notice Board*
SHB003	Magnetic Easy Wipe Board - White Only
SHB004	Dry Cleaning Board*
SHB005	Wet Cleaning Board*
SHB006	XL Cleaning Board*
SHB007	First Aid Board*
SHB009	Eyewash/Accident Board*
SHB010	Fire Safety Board*

* Please state colour required when ordering - (/B) Blue, (/G) Green, (/R) Red and (/Y) Yellow.



MODULEAN® RACK END BOARDS

Transform dead-space
into working-space!



- ➔ Keep your warehouse organised with Modulean® Rack End Boards
- ➔ 2000mm high x 900mm wide, suitable for warehouse racking
- ➔ Make use of otherwise redundant end of aisle racking space
- ➔ A range of standard boards available
- ➔ Supplied with the products on display
- ➔ Each board is available with either single or double aisle markers

Being 2000mm high x 900mm wide, these Rack End Boards have been designed to fit warehouse end of aisle racking systems. 1100mm wide boards are also available to order to suit both sizes of pallet racking – please contact the sales office for details.

Available in 7 shadow board designs, each in 4 different colour options - blue, green, red and yellow. Each board is available with either single or double aisle markers in the form of our best seller frames4docs®, making the inserts easy to change and replace as frequently as required.

Aisle markers can be printed with inserts to suit your warehouse needs - please let us know what aisle information you need.



We Recommend!

See page 91 for
Brandsafe® Barriers



SHADOW BOARDS

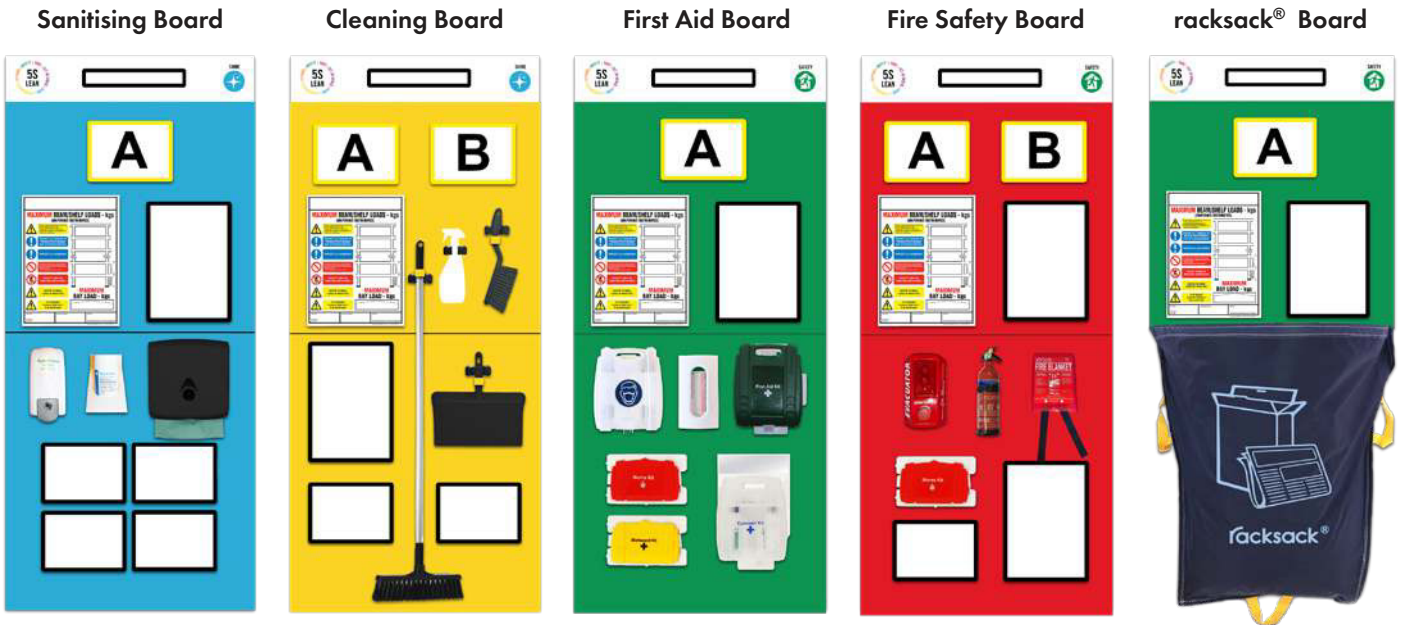

Supplied with the products on display including a title frame, as well as fixings, we've made it as easy as possible for you to install a Modulean® Rack End Board in your warehouse.

To help you comply with regulations, a weight load notice is also included with each board, which are mandatory for all racking. Weight load notices can be printed with weight limits and information – please confirm the details you need printed. If no information is received these will be supplied blank for you to add your own information by simply writing on them with a marker pen.

Rack Assessment Board

White Board

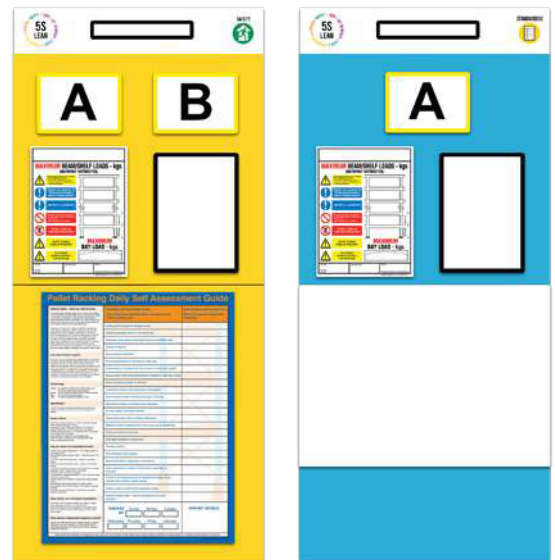

Other designs and bespoke boards can be produced, please contact us for further details



Modulean® Rack End Boards

Ref	Description
REBS001	Sanitising Board* - Single Marker
REBD001	Sanitising Board* - Double Marker
REBS002	Cleaning Board* - Single Marker
REBD002	Cleaning Board* - Double Marker
REBS003	First Aid Board* - Single Marker
REBD003	First Aid Board* - Double Marker
REBS004	Fire Safety Board* - Single Marker
REBD004	Fire Safety Board* - Double Marker
REBS005	racksack® Board* - Single Marker
REBD005	racksack® Board* - Double Marker
REBS006	Rack Assessment Board* - Single Marker
REBD006	Rack Assessment Board* - Double Marker
REBS007	White Board* - Single Marker
REBD007	White Board* - Double Marker

➔ *Please state colour required when ordering - (/B) Blue, (/G) Green, (/R) Red and (/Y) Yellow.

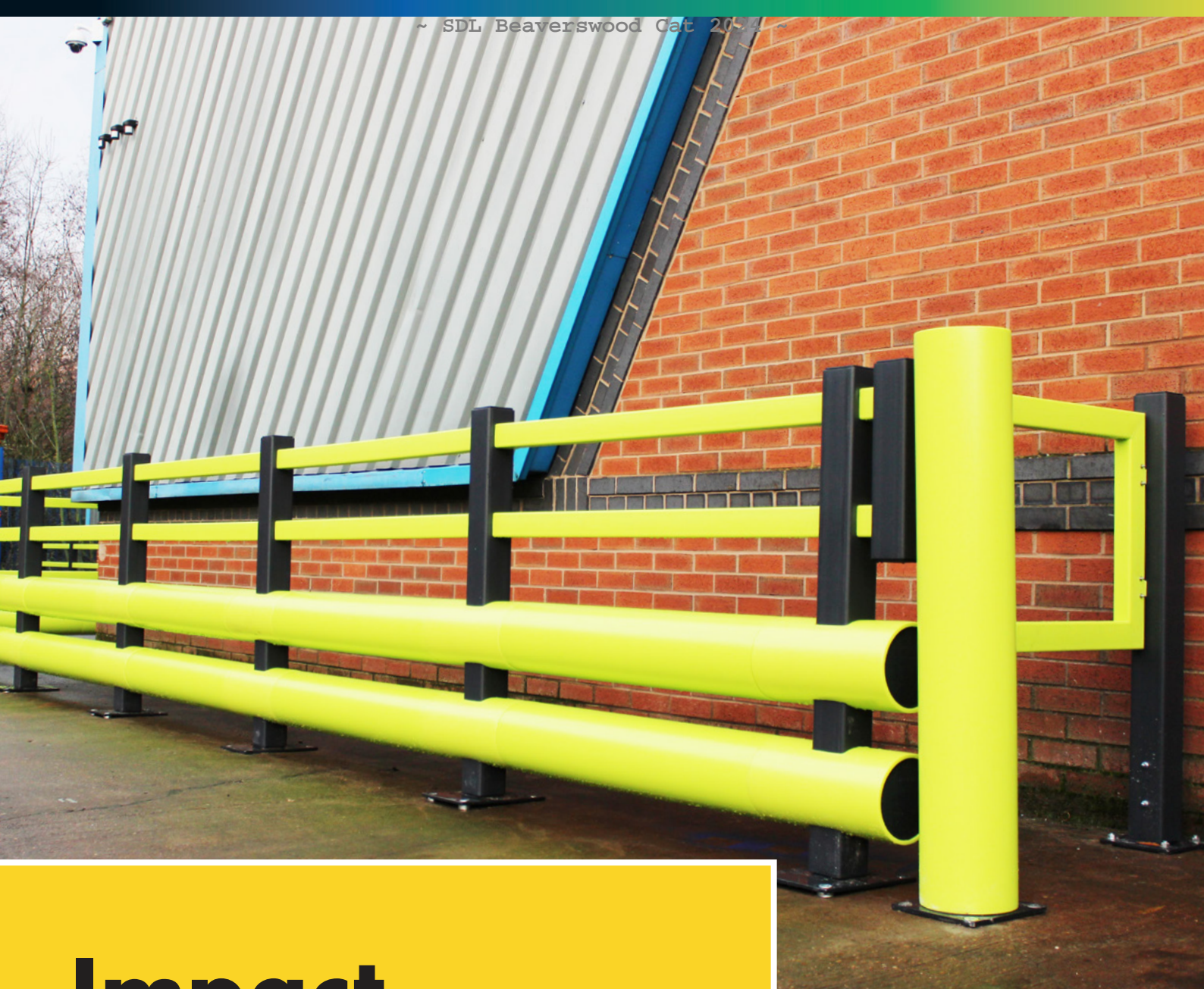

Impact Protection

We're delighted to offer an innovative range of impact protection and high-visibility safety products from market leaders Brandsafe® and Rack Armour®.

These products are designed to reduce the chance of collisions and accidents on site, saving you money on otherwise costly repairs.

They can be used internally and externally to prevent damage and protect people from harm.

From heavy-duty safety bollards (ideal for corners, entrances, and structures) to low-level bumper barriers (perfect for identifying working boundaries) – we have it all!

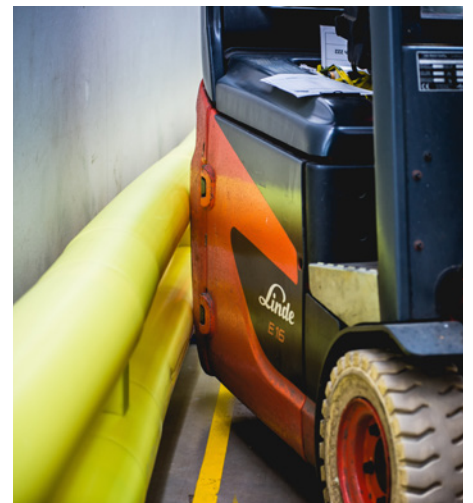

Armco Accessories



Fitted with diamond grade reflectors for added visibility

Protect your assets and personnel in the workplace

- ➔ Polymer moulded Armco accessories
- ➔ Provides a safe and visual termination to sharp Armco rails
- ➔ Retrofit compatibility with all Armco terminals
- ➔ Flexible under impact



Improve safety in the workplace with the Armco safety range. Available for steel corners and ends - with three different end designs (standard, pedestrian and fishtail).

Made from polymer, these Armco accessories are highly visible, simple and quick to install. Designed with retrofit compatibility with all steel armco rails, to save costs and install time.

The range is available in Yellow or Black, which contrasts against the steel of the barriers. Together, with diamond grade reflectors, they not only offer an aesthetic look but also contribute towards safety. All fixings included.



All fixings included

Each Armco end is available in Yellow or Black

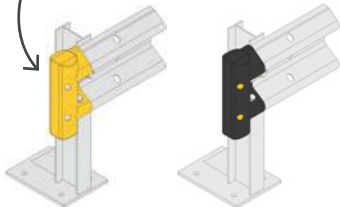

Armco Accessories

Ref	Description
ASCE90	Armco External Corner 90°
ASCE135	Armco External Corner 135°
ASCIN90	Armco Internal Corner 90°
ASCIN135	Armco Internal Corner 135°
ASE	Armco Safety End
AFSE	Armco Fishtail Safety End
APSE	Armco Pedestrian Safety End

➔ Please state colour required when ordering - (/Y) Yellow and (/BK) Black.



PolyWRAP SpaceSaver Column Protectors

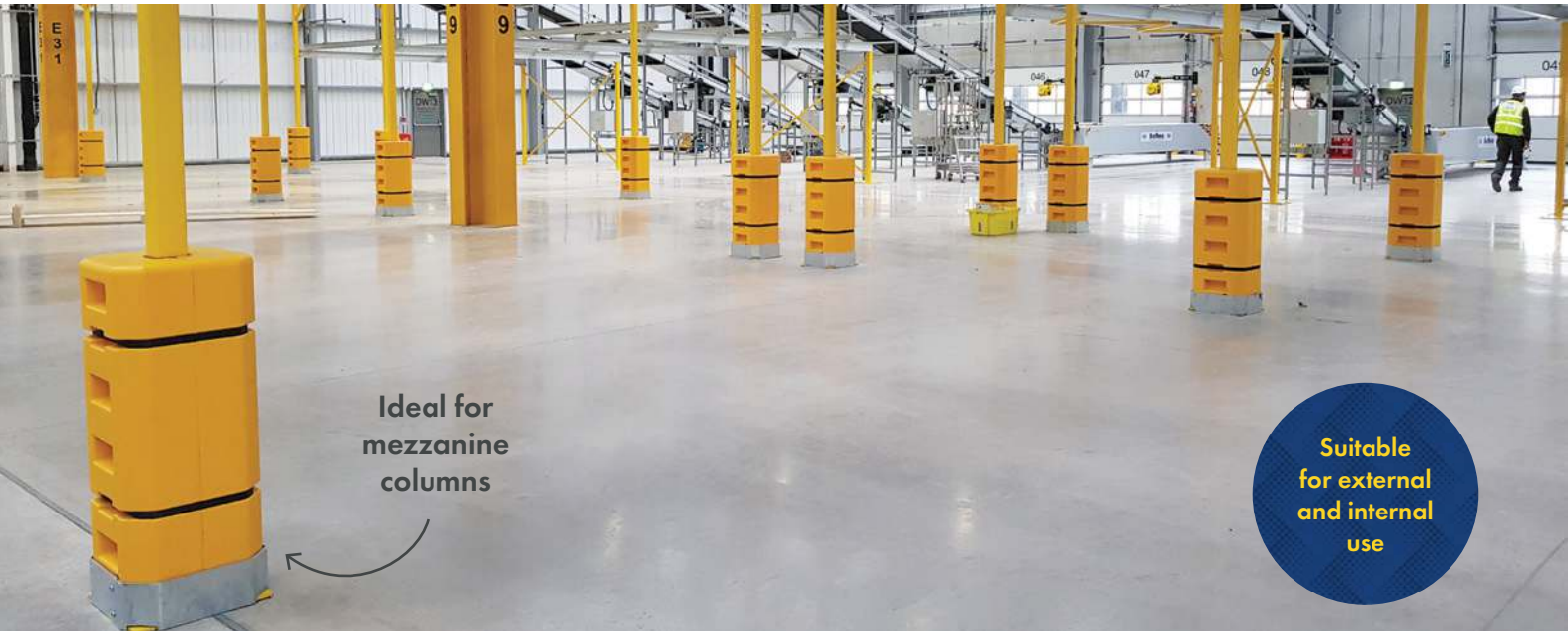

Ideal for mezzanine columns

Suitable for external and internal use

- ➔ Designed to save valuable space and protect columns
- ➔ 5 size options moulded to fit snug to your specific column size
- ➔ Recess feature to cover base plates and studs 320mm x 320mm
- ➔ Ratchet security strapping
- ➔ Simple and quick to install - no mechanical fixing needed

These column protectors are quick and easy to install and are made from 100% recyclable polyethylene. They are ideal for protecting mezzanine columns without taking up valuable floor space.

Foam Inserts

When the actual column is approximately 20mm smaller than the standard PolyWRAP column sizes – then a foam insert is required (2 per column). These are cut to order to ensure it fits perfectly to your column. If you're unsure, please contact the sales office.

SpaceSaver Column Protectors

Ref	Column Size To Fit (h x w)
SCP03	100mm x 100mm
SCP04	120mm x 120mm
SCP05	152mm x 152mm
SCP06	203mm x 203mm
SCP07	250mm x 250mm



Overall Dimensions
410mm x 410mm x 1045mm High

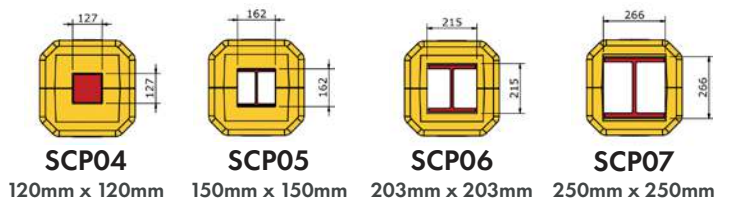
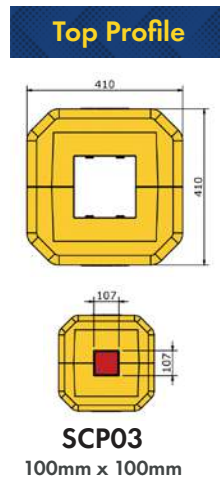

Foam Inserts

Ref	Description
SCP/FI	Foam Insert x 2



Optional 140mm High Steel Fork Impact Skirt

Ref	Description
SCP/SK	High Steel Fork Impact Skirt

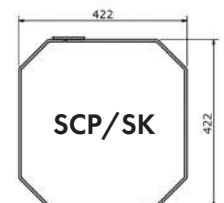

PolyWRAP Column Protectors



A must-have
for forklift
trucking
routes



Ideal for
structural columns

- ➔ Designed to fit a range of common structural steel columns
- ➔ 8 size options moulded to fit snug to your specific column size
- ➔ Recess feature to cover base plates and studs 500mm x 500mm
- ➔ Ratchet security strapping
- ➔ Simple and quick to install - no mechanical fixing needed

Column Protectors

Ref	Column Size To Fit (h x w)
CPR01	152mm x 152mm
CPR02	203mm x 203mm
CPR03	254mm x 254mm
CPR04	305mm x 305mm
CPR05	356mm x 368mm
CPR06	406mm x 406mm
CPR07	610mm x 305mm
CPR08	914mm x 305mm

Foam Inserts

When the actual column is approximately 20mm smaller than the standard PolyWRAP column sizes – then a foam insert is required (2 per column). These are cut to order to ensure it fits perfectly to your column. If you're unsure, please contact the sales office.

Ref	Description
CPR/FI	Foam Insert x 2



Side Profile

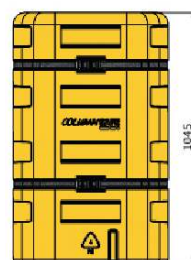

Top Profile

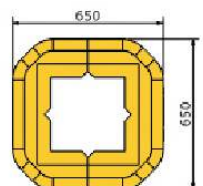

Overall Dimensions
Unless indicated - 650mm x 650mm x 1045mm high

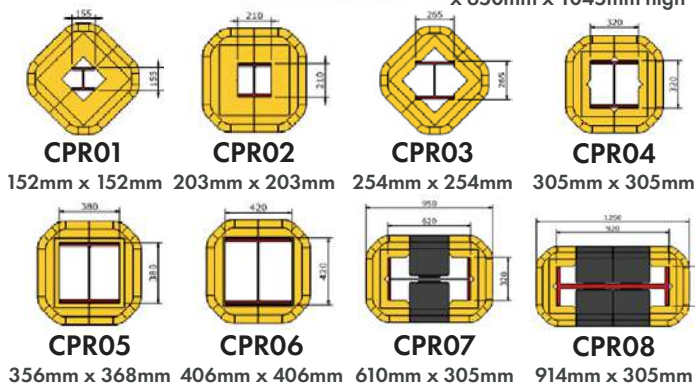

Still not sure?

Contact the sales office and tell us what size columns you have and we will advise the correct option.

Optional 140mm High Steel Fork Impact Skirt

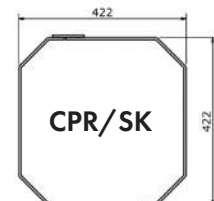

Ref	Description
CPR/SK	High Steel Fork Impact Skirt

Flexi Delineators

Suitable for tarmac or concrete



- ➔ Polyurethane posts that will flex, bend and crush, then return to shape
- ➔ 80mm diameter posts supplied with 3 floor anchor bolts
- ➔ 1000mm high
- ➔ Choice of 3 high visibility colours

These flexi posts are ideal where demarcation of traffic routes are paramount for safety. The posts can be used on their own or combined with plastic chains to help segregate traffic and pedestrian routes.

Ref	Description
FDP/Y	Yellow Post with Silver Reflectors
FDP/W	White Post with Red Reflectors
FDP/B	Black Post with Yellow Reflectors
FDK/FK	Chain Fixing Kit
PCH/BY	Black and Yellow 8mm Plastic Chain x 25M
PCH/RW	Red and White 8mm Plastic Chain x 25M



Chain Fixing Kit comprises of 1x Top Cap and 2x S-Clips. 1x Chain Fixing Kit is needed per post. (please order separately)



Speed Bumps

- ➔ Available in 2 heights
- ➔ Suitable for domestic and commercial vehicles
- ➔ Individual Yellow and Black speed bumps



These compression moulded speed bumps help calm the speed of vehicles, with a choice of 2 sizes: 50mm high suited to domestic vehicles, and 75mm high suited to commercial applications.

Sold in individual units, each Speed Bump section is 500mm long. End sections are 210mm long.

Ref	Description
SB50	50mm High Speed Bump Section
SBE50	50mm End Section
SB75	75mm High Speed Bump Section
SBE75	75mm End Section
SBFIX	Pack of 4 Fixing Bolts and Plugs

➔ Please state colour required when ordering - (/Y) Yellow and (/B) Black.

Fixing bolts are supplied separately - suitable for use in both tarmac and concrete - sold in packs of 4. Each individual Speed Bump section requires 4 bolts. End sections require 2 bolts.

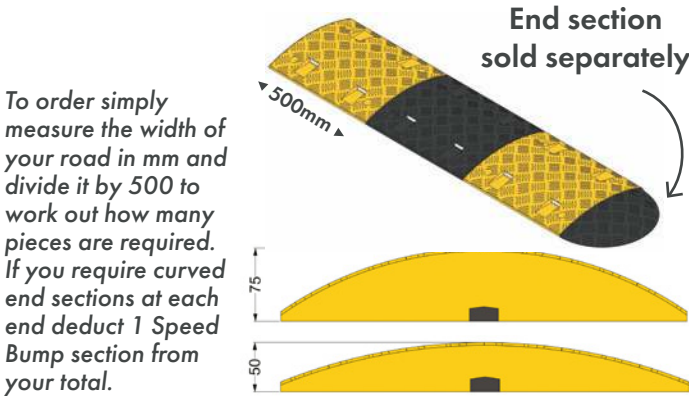

Lamp and Sign Post Protectors



- ➔ Easy to install clam-shell design
- ➔ Highly visible colours and diamond grade reflector band
- ➔ Replace the Lamp Post Wrap not the lamp post
- ➔ Available in 1250mm high kits

Moulded in the UK from tough Polyethylene, these radical new protectors with high density foam impact absorbing cores make vulnerable lamp posts visible to drivers.

All kits come with a foam core suitable for all sizes. Five high visibility colours available.

Ref	Description
LPK/YS	Yellow and Silver Hi Vis
LPK/BS	Black and Silver Hi Vis
LPK/BY	Black and Yellow Hi Vis
LPK/GS	Green and Silver Hi Vis
LPK/RS	Red and Silver Hi Vis



Wheel Stops

- ➔ Hi vis strip for pedestrian and driver visibility
- ➔ Manufactured from robust and semi-flexible PVC
- ➔ Supplied with Fixing Kit

Wheel Stops that cater for all domestic and commercial vehicles including: cars, vans, coaches, trucks, HLGVs / HGVs. They are ideal for controlling the parking of all vehicles. Designed to eradicate bending and splitting associated with hollow rubber Wheel Stops. Fixings provided are suitable for concrete and tarmac substrates.

Commercial Wheel Stops are only available in Yellow or Black, whereas domestic Wheel Stops are available in Yellow, Black or Red.

Ref	Description	Size (l x w x h)
DWS	Domestic Wheel Stop	900mm x 200mm x 80mm
CWS	Commercial Wheel Stop	1000mm x 200mm x 130mm

➔ Please state colour required when ordering - (/Y) Yellow, (/B) Black and (/R) Red.



Domestic Wheel Stop

Commercial Wheel Stop



Electric Vehicle Protection Kits

- ➔ Strong and robust impact protection for charging points
- ➔ Three standard product packages to choose from
- ➔ Domestic, commercial and industrial applications
- ➔ Cost-effective coverage for assets
- ➔ Bespoke solutions upon request



Medium Duty Kit

A range of impact protection for EV charging points.

Light Duty Kit includes: 2 Protection Posts.

Ideal for private and small car parks.

Medium Duty Kit includes: 2 Protection Posts and 1 Domestic Wheel Stop.

For industrial and larger public car parks, when there is a medium-to-high risk of impact damage.

Heavy Duty Kit includes: 2 Bollards, 1 Commercial Wheel Stop and optional Armco Safety Barriers.

For when larger industrial vehicles, such as HLGVs and HGVs, are being used regularly.



Light Duty Kit



Heavy Duty Kit

Ref	Description
EVKIT/LD	Light Duty Kit
EVKIT/MD	Medium Duty Kit
EVKIT/HD	Heavy Duty Kit

Electric Vehicle Charging Stencil Kits

- ➔ A cost-effective, highly visible and long lasting solution
- ➔ Help drivers locate the correct area efficiently to charge their electric vehicle
- ➔ Stencil is 600mm x 600mm



3 Stencil Kits to choose from

Ref	Description	Size (h x w)
STENEV	Stencil Only	600mm x 600mm
STENEV-KIT	Stencil Kit*	600mm x 600mm

➔ *Please state colour required when ordering - (/RE) Red, (/YE) Yellow and (/WH) White.



Rack End Barriers

- ➔ Manufactured from a flexible HDPE polymer with a foam diffuser
- ➔ Deflects under impact
- ➔ Single or double barrier options
- ➔ Available in 2 sizes
- ➔ Quick and easy installation

The flexible barrier design, absorbs the load of impact, away from a vehicle and ground fixings to minimise damage and repair time.

Available in single or double barrier options - single barriers stand at 320mm high and double barriers at 620mm high.

Fully recyclable, non-toxic and suitable for use in food production and freezer environments. All fixings provided.

The barriers are available in three colours, making them highly visible to personnel and vehicles. These low maintenance polymer barriers, don't rust, corrode, fade or require re-painting.

Low Level Bumper Barriers

- ➔ Manufactured from a flexible HDPE polymer with a foam diffuser
- ➔ Deflects under impact
- ➔ Single or double barrier options
- ➔ Available in 3 sizes
- ➔ Quick and easy installation

These low level bumper barriers offer complete warehouse protection by creating safe zones of highly visible barrier systems. They provide the right amount of visibility and strength, whilst maximising space.

Available in single or double bumpers, depending on the level of protection required - single barriers stand at 310mm high and double barriers at 600mm high.

Fully recyclable, non-toxic and suitable for use in food production and freezer environments. All fixings provided.

The barriers are available in three colours, making them highly visible to personnel and vehicles. These low maintenance polymer barriers, don't rust, corrode, fade or require re-painting.



Available in 2 sizes - 1200mm and 2400mm

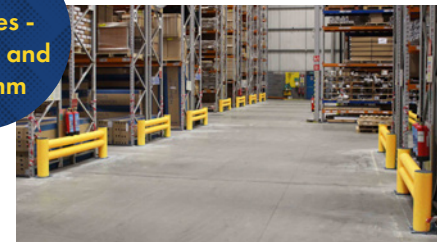

Ref	Description	Width
RBBS12	Single Rack End Barrier	1200mm
RBBS24	Single Rack End Barrier	2400mm
RBBD12	Double Rack End Barrier	1200mm
RBBD24	Double Rack End Barrier	2400mm

➔ Please state colour required when ordering - (/CYG) Colourfast Yellow & Grey, (/HVB) Hi Vis Yellow & Blue and (/SYG) Safety Yellow & Grey.

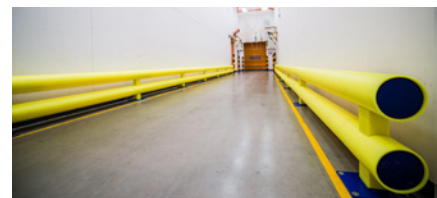

Ref	Description	Width
LBBS19	Single Low Level Bumper Barrier	1900mm
LBBS34	Single Low Level Bumper Barrier	3400mm
LBBS49	Single Low Level Bumper Barrier	4900mm
LBBD19	Double Low Level Bumper Barrier	1900mm
LBBD34	Double Low Level Bumper Barrier	3400mm
LBBD49	Double Low Level Bumper Barrier	4900mm

➔ Please state colour required when ordering - (/CYG) Colourfast Yellow & Grey, (/HVB) Hi Vis Yellow & Blue and (/SYG) Safety Yellow & Grey.

Pedestrian Barriers

- ➔ Manufactured from HDPE polymer
- ➔ Designed with safety and segregation in mind
- ➔ High visibility colours highlight safe pedestrian areas
- ➔ Available in 3 sizes

These highly durable pedestrian barriers are ideal for highlighting safe pedestrian areas and guiding people in the right direction, internally or externally.

The barriers are available in three colours, making them highly visible to personnel and vehicles. These low maintenance polymer barriers, don't rust, corrode, fade or require re-painting.

Available in 3 size widths - 1500mm, 3000mm or 4500mm, all with 3 rails. Other sizes are available upon request, subject to minimum quantity. Please note, these barriers do not act as impact protection alone.



Add bumpers for impact protection

Ref	Description	Width
PB315	Pedestrian Barrier - 3 rail	1500mm
PB330	Pedestrian Barrier - 3 rail	3000mm
PB345	Pedestrian Barrier - 3 rail	4500mm

➔ Please state colour required when ordering - (/CYG) Colourfast Yellow & Grey, (/HVB) Hi Vis Yellow & Blue and (/SYG) Safety Yellow & Grey.

Pedestrian Bumper Barriers

- ➔ Manufactured from HDPE polymer
- ➔ The bumpers add extra deflection and strength to the pedestrian barriers
- ➔ Single or double bumper options
- ➔ Available in 3 sizes
- ➔ High visibility colours for pedestrians

Where pedestrians and MHE frequently pass each other, there is no better protection than the pedestrian bumper barriers.

Easy to see and durable, they are ideal for warehouse and pedestrian segregation. Fully recyclable, non-toxic and suitable for use in food production and freezer environments. All fixings provided.

Available in single or double barrier bumper options depending on the busyness of your warehouse.

The barriers are available in three colours, making them highly visible to personnel and vehicles. These low maintenance polymer barriers, don't rust, corrode, fade or require re-painting.



Single or double bumper options

Ref	Description	Width
PBBS19	Single Bumper Pedestrian Barrier	1900mm
PBBS34	Single Bumper Pedestrian Barrier	3400mm
PBBS49	Single Bumper Pedestrian Barrier	4900mm
PBBD19	Double Bumper Pedestrian Barrier	1900mm
PBBD34	Double Bumper Pedestrian Barrier	3400mm
PBBD49	Double Bumper Pedestrian Barrier	4900mm

➔ Please state colour required when ordering - (/CYG) Colourfast Yellow & Grey, (/HVB) Hi Vis Yellow & Blue and (/SYG) Safety Yellow & Grey.

Heavy Duty Bollards

- ➔ Manufactured from ballistics grade materials
- ➔ Ideal for corners, entrances and structures
- ➔ Deflects under impact without damage
- ➔ Available in 4 size heights

These heavy duty safety bollards are a cost effective solution to protect corners, entrances and structures.

Manufactured from HDPE, these bollards are able to take the impact of multiple hits and simply reform afterwards with little or no damage.

Available in 4 heights - 600mm, 900mm, 1200mm or 1600mm. Standard 200mm tube width. Other sizes are available upon request, subject to minimum quantity.

The bollards are available in three colours, making them highly visible to personnel and vehicles. These low maintenance polymer bollards, don't rust, corrode, fade or require re-painting.

Floor Level Barriers

- ➔ Manufactured from ballistics grade materials
- ➔ Provides subtle protection at low levels
- ➔ Ideal for placing behind bays
- ➔ Available in 2 sizes
- ➔ High visibility colours

These floor level barriers are ideal for providing subtle protection at low levels from order pickers, with minimal space intrusion in the warehouse.

Available in 2 size lengths - 800mm or 1200mm.

Manufactured from ballistics grade materials and fixed to the floor, these barriers are strong and durable enough to take knocks and bumps. They are ideal to prevent pallets being hit against walls.

The barriers are available in three colours, making them highly visible to personnel and vehicles. These low maintenance polymer barriers, don't rust, corrode, fade or require re-painting.

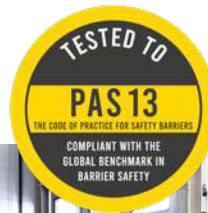

Gives safe working boundaries for MHE drivers



Ref	Description	Height
HDB60	Heavy Duty Safety Bollard	600mm
HDB90	Heavy Duty Safety Bollard	900mm
HDB12	Heavy Duty Safety Bollard	1200mm
HDB16	Heavy Duty Safety Bollard	1600mm

➔ Please state colour required when ordering - (/CYG) Colourfast Yellow & Grey, (/HVB) Hi Vis Yellow & Blue and (/SYG) Safety Yellow & Grey.



Can be used in combination with other barriers for extra protection

Strong and durable protection at low levels



Ref	Description	Length
KBB80	Floor Level Barrier	800mm
KBB12	Floor Level Barrier	1200mm

➔ Please state colour required when ordering - (/CYG) Colourfast Yellow & Grey, (/HVB) Hi Vis Yellow & Blue and (/G) Grey.



Rack Armour® Upright Protection

- ➔ Manufactured from ballistics grade plastic which deflects under impact
- ➔ 2 patented designs
- ➔ Proven to reduce racking damage
- ➔ Lifespan of 15 years +
- ➔ Zero maintenance and no floor damage from impact
- ➔ Easy installation - no fixings required



Rack Armour® has been a global success for over a decade. Its innovative design and functionality has revolutionised racking protection and provides a proven reduction in damage levels - saving time, money and hassle.

Its tight fit ensures that Rack Armour® can't be knocked off whilst pallets are retrieved. When a direct impact occurs and cannot be deflected by the outer shell, the interior foam absorbs the impact energy until it's diffused. These upright protectors fit all makes of pallet racking and are transferable. Made from ballistics grade plastic which is non toxic and fully recyclable.

Rack Armour® has been tested to meet and exceed European and Australian safety standards, including EN 15512 and AS4100.

Available from stock in two highly visible colours that clearly gives safe working boundaries for MHE drivers. Other colour options are available - please contact the sales office for further details.



Save time and money on repairs



IMPACT PROTECTION



Your logo or contact details here

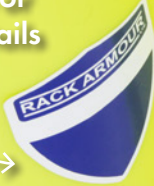

Brand your Rack Armour® Labels

Please provide us with your logo, phone number, email address and website address and we can create personalised labels for you.

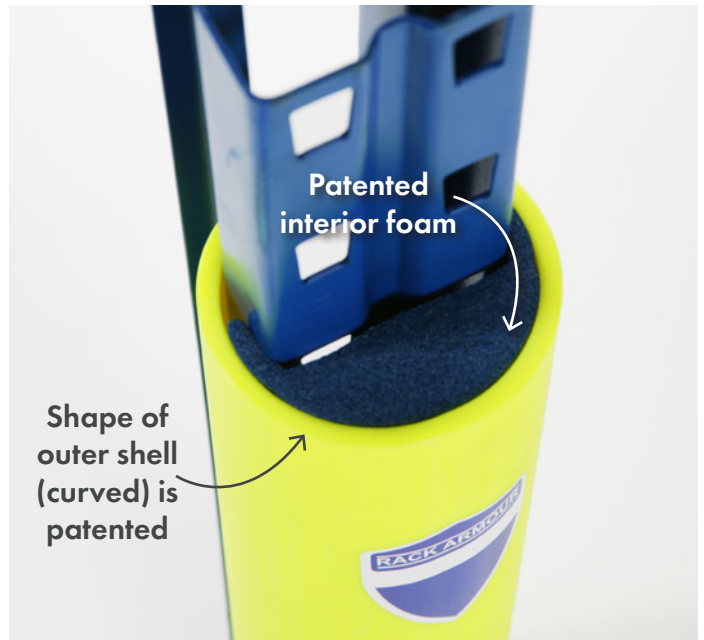

Patented interior foam

Shape of outer shell (curved) is patented



Hi Vis Yellow



Safety Yellow

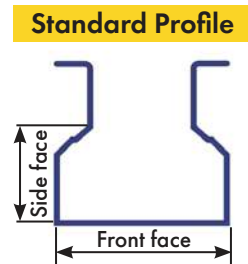
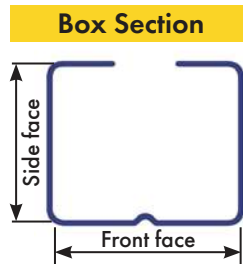

Rack Armour® Upright Protector

Ref	Description	Upright Width
RAP70*	Rack Armour Upright Protector	Small 70mm - 87mm
RAP88*	Rack Armour Upright Protector	Medium 88mm - 100mm
RAP10*	Rack Armour Upright Protector	Large 101mm - 110mm
RAP111*	Rack Armour Upright Protector	XL 111mm - 120mm
RAIT/S	Installation Tool - Hooks	All Sizes
RAIT/L	Installation Tool - Arms	All Sizes

► *Please state colour required when ordering - (/LY) Hi Vis Yellow and (/Y) Safety Yellow.



Other high vis colours also available to order – contact the sales office for further details



Shelving and Storage

A well-organised warehouse, workshop, or storage space is essential to any business, which is why we're proud to offer a wide selection of high-quality storage and shelving products from Anco®.

Whether you need rivet racking for storing long or bulky items, or bin shelving for small parts and tools, we've got you covered!

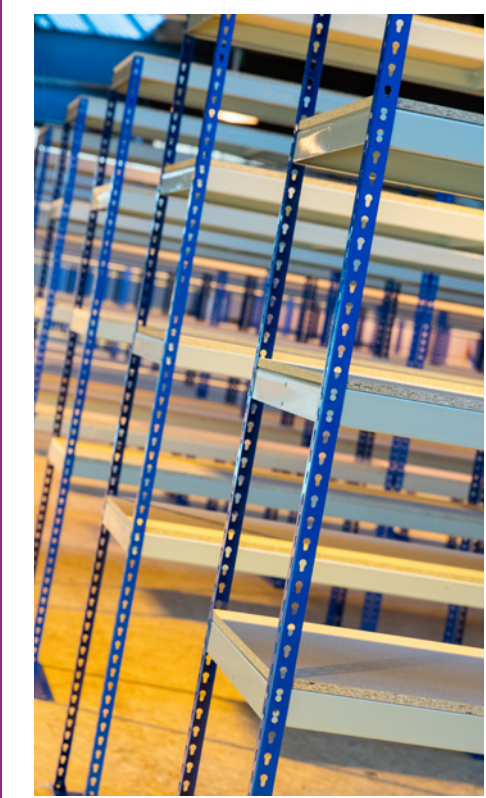

Shelf Trays on Racks

- ➔ Designed for strength and ease
- ➔ Trays are available in 3 depths, 2 widths and 2 heights
- ➔ All bays are complete with white shelves and fixings
- ➔ Labels included with every plastic tray

The shelf trays feature a spring loaded shelf stop at the back of the tray. This means the tray can be withdrawn from the shelf and suspended offering around 90% clear picking. This stop also acts as a handle to make it easier to carry.

With shelf trays available in 3 depths, 2 widths and 2 heights any configuration can be designed to offer the maximum high density storage solution. Trays can be sub divided from left to right and all trays and dividers come with labels.

Ideal for the warehouse, workshop and storeroom

ANCO STORAGE



Capacity Up to 120kg Shelf Load



BAY E -
Includes 32 trays - 117mm x 90mm,
16 trays - 234mm x 90mm,
20 trays - 234mm x 140mm



BAY F -
Includes 120 trays -
117mm x 90mm



BAY G -
Includes 60 trays -
234mm x 90mm



BAY H -
Includes 44 trays -
234mm x 140mm

Shelf Trays On Racks

Starters

Ref	Depth (h x w)
BAY E 2000mm x 1000mm	
STE03S	300mm
STE04S	400mm
STE05S	500mm
BAY F 2000mm x 1000mm	
STF03S	300mm
STF04S	400mm
STF05S	500mm
BAY G 2000mm x 1000mm	
STG03S	300mm
STG04S	400mm
STG05S	500mm
BAY H 2000mm x 1000mm	
STH03S	300mm
STH04S	400mm
STH05S	500mm

Extensions

Ref	Depth (h x w)
BAY E 2000mm x 1000mm	
STE03E	300mm
STE04E	400mm
STE05E	500mm
BAY F 2000mm x 1000mm	
STF03E	300mm
STF04E	400mm
STF05E	500mm
BAY G 2000mm x 1000mm	
STG03E	300mm
STG04E	400mm
STG05E	500mm
BAY H 2000mm x 1000mm	
STH03E	300mm
STH04E	400mm
STH05E	500mm

- ➔ Other variations are available, please contact our sales office.
- ➔ All bays are complete Expo 4 bays with white shelves and fixings.

Medium Rivet Racking

ANCO STORAGE

MRB/06



- ➔ Cost effective solution for storing long or bulky items
- ➔ Offers shelf loads of up to 300kg (UDL) and bay loads of 2800kg.
- ➔ Highly flexible industrial shelving, offering you strength and versatility

Our Medium Rivet uses a lighter 1830mm "L" shape face beam. Medium Rivet bays are available in depths from 305mm to 1220mm deep.

The quality of the materials and robust construction ensures it will meet the rigors of the toughest workplace. The vast range of bay sizes allows for a solution to meet your storage needs and the available space.

We Recommend! See page 112 for racksack® mini

Medium Rivet Bays

Ref	Size (h x w x d)	Shelf Load
MRB/03	1830mm x 1830mm x 305mm	300kg
MRB/04	1830mm x 1830mm x 457mm	300kg
MRB/06	1830mm x 1830mm x 610mm	300kg
MRB/07	1830mm x 1830mm x 762mm	280kg
MRB/09	1830mm x 1830mm x 915mm	250kg
MRB/12	1830mm x 1830mm x 1220mm	230kg

+ Adding Extra Shelf

Ref	Works With
MRS/03	Medium Rivet Bay - MRB/03
MRS/04	Medium Rivet Bay - MRB/04
MRS/06	Medium Rivet Bay - MRB/06
MRS/07	Medium Rivet Bay - MRB/07
MRS/09	Medium Rivet Bay - MRB/09
MRS/12	Medium Rivet Bay - MRB/12

➔ Price includes four levels, uprights, plastic feet, perimeter beams, deck supports and chipboard decking.



Available Heights

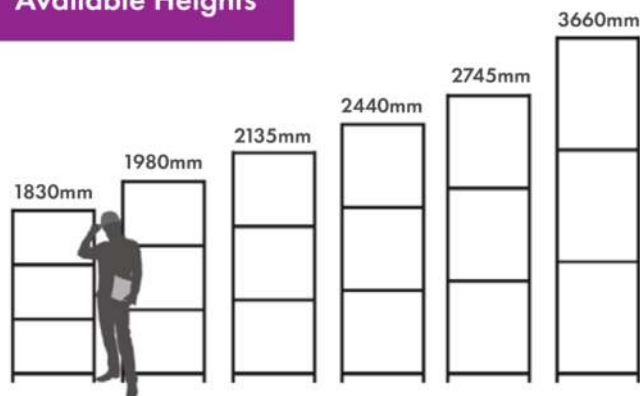

Accessories

Ref	Description
MAL	Rubber Mallet
TP/4	Tie Plate x 4
WBKT	Wall Bracket
MF/4	Metal Feet x 4
FFM/50	Floor Fixing M8 x 50



+ For Taller Bays Add Price

Ref	Extra Height
RRB/19	Bays 1980mm
RRB/21	Bays 2135mm
RRB/24	Bays 2440mm
RRB/27	Bays 2745mm
RRB/30	Bays 3050mm
RRB/36	Bays 3660mm

Rivet Racking Bays with Bins



- ➔ Strong, robust and versatile bin storage solution for any workplace
- ➔ Ensure items can be identified quickly
- ➔ Three options of shelf bins
- ➔ Each shelf bin kit includes Rivet Racking bay with 7 shelf levels

Our range of Rivet Racking bays with bins have been designed to offer a range of shelf bins in 'larger sizes' for storing increased volumes.

Available in three shelf bin options - 280mm wide, 420mm wide or a mixed variation of these sizes.

Shelf bins with a semi-open front and a large labelling area, it ensures items can be identified efficiently. The bins are available in blue shockproof plastic and can be nested when not in use to save space.

Get organised and label your shelf bins with Label Holders. [Please see page 14.](#)



Rivet Racking with 18 - 280mm shelf bins



Rivet Racking with 12 - 420mm shelf bins



Rivet Racking with 9 - 280mm shelf bins and 6 - 420mm shelf bins

280mm wide shelf bins



420mm wide shelf bins



Capacity Up to 600kg Shelf Load

Organise and label your shelf bins



We Recommend!

See page 14 for Self-adhesive Label Holders



Rivet Racking Bays with Bins

Ref	Racking Size (h x w x d)	Bin Description
RRSFB03A	1980mm x 915mm x 305mm	
RRSFB04A	1980mm x 915mm x 457mm	18 bins - 280mm
RRSFB06A	1980mm x 915mm x 610mm	
RRSFB04B	1980mm x 915mm x 457mm	12 bins - 420mm
RRSFB06B	1980mm x 915mm x 610mm	
RRSFB04C	1980mm x 915mm x 457mm	9 bins - 280mm & 6 bins - 420mm
RRSFB06C	1980mm x 915mm x 610mm	

Component Organisers

- ➔ Ideal for organising your small parts storage
- ➔ Manufactured from high quality polypropylene
- ➔ 8 options available to suit your needs
- ➔ Suitable for any workplace

**Component Organiser
12 Drawers**



**Includes:
8 x ACO DB Drawers and
4 x ACO DS Drawers**

**Component Organiser
22 Drawers**



**Includes:
8 x ACO DB Drawers and
14 x ACO DS Drawers**

**Component Organiser
9 Bins and 9 Drawers**



**Includes:
9 x ACO BIN Bins and
9 x ACO DB Drawers**

**Component Organiser
9 Bins and 30 Drawers**



**Includes:
9 x ACO BIN Bins and
30 x ACO DS Drawers**

Component organisers are the ideal small parts organiser for your item storage needs. The body and frame are made from durable high impact polypropylene and the drawers and partitions are made from transparent polypropylene.

Each drawer comes with its own removable horizontal partition, effectively doubling the number of compartments which can be used in the component organiser.

The component organisers can be screwed directly on a wall with the pre-configured holes or mounted on a wall with specially designed frames.

The component organisers can be mounted on metal louvre panels with the help of four clips for better mounting which can be fitted on the back wall of the cabinet.

ACO DB Drawers
153mm x 58mm x
127mm



ACO DS Drawers
62mm x 37mm x
153mm



ACO BIN Bins
153mm x 65mm x
127mm



**Component Organiser
18 Drawers**



**Includes:
18 x ACO DB Drawers**

**Component Organiser
39 Drawers**



**Includes:
9 x ACO DB Drawers and
30 x ACO DS Drawers**

Component Organisers

Ref	Size (w x h x d)
Component Organiser with 12 Drawers	
ACO12	293mm x 245mm x 164mm
Component Organiser with 22 Drawers	
ACO22	555mm x 245mm x 164mm
Component Organiser with 9 Bins and 9 Drawers	
ACO9B3D	424mm x 457mm x 164mm
Component Organiser with 9 Bins and 30 Drawers	
ACO9B30D	424mm x 457mm x 164mm
Component Organiser with 18 Drawers	
ACO18	424mm x 457mm x 164mm
Component Organiser with 39 Drawers	
ACO39	424mm x 457mm x 164mm
Component Organiser with 60 Drawers	
ACO60	424mm x 457mm x 164mm
Component Organiser with 12 Pockets with Lids	
ACO12PTL	426mm x 460mm x 166mm

**Component Organiser
60 Drawers**



**Includes:
30 x ACO DS Drawers**

**Component Organiser
12 Pockets with Lids**



**Centre pocket:
123mm x 125mm x 68mm
Side pocket:
100mm x 125mm x 70mm**

Clicka Shelving

ANCO STORAGE

- ➔ Best value shelving system
- ➔ Up to 265kg shelf capacity
- ➔ Superior quality and strength
- ➔ Robust and strong – Fully tested and certified by GS TUV
- ➔ Easy to assemble and re-configure
- ➔ Build a bay in less than 10 minutes with just a rubber mallet

Clicka shelving offers a solution to your storage needs, as well as your budget.

It is simple to put together, yet has all the strength you are likely to require. Available in 175kg and 265kg shelf capacities. Manufactured with high quality materials and finish, you can have peace of mind that our Clicka system has been tested and certified to the highest European standards – GS TUV.

Whether you are fitting out the home or workplace, our Clicka shelving kits offers strength and simplicity at an incredible price.



Clicka 175



We Recommend!

See page 14 for Self-adhesive Label Holders



Available in
175kg to 265kg
Shelf
Capacities

Clicka Galvanised 265
(Mesh Decking)

Clicka Shelving

Ref	Size (h x w x d)	Shelf Load
Clicka 175 (MDF)		
CL175A	1800mm x 900mm x 450mm	175kg
CL175B	1800mm x 900mm x 600mm	175kg
Clicka Galvanised 265 (Mesh Decking)		
RB350M	1980mm x 1200mm x 600mm	265kg

Long Rivet Packing Workstation

Capacity
Up to 300kg
Bench Load

ANCO STORAGE

- ➔ Long packing bench with lower bubble wrap dispenser and upper paper roll dispenser
- ➔ Cost-effective and easy to use
- ➔ Two width options available
- ➔ Includes upper and lower shelves for additional storage

Our Long Rivet Packing Workstations come with an upper storage level for additional storage and, depending on the bench configuration, you get a lower storage level as well. Ideal for order processing, packing and manufacturing.

Each order includes uprights, plastic feet, all necessary beams, chipboard tops and 2 roll dispensers. All dispensers are simply and quickly lifted out to change the rolls.

Two width options available - 915mm and 1220mm.



RRLPS09

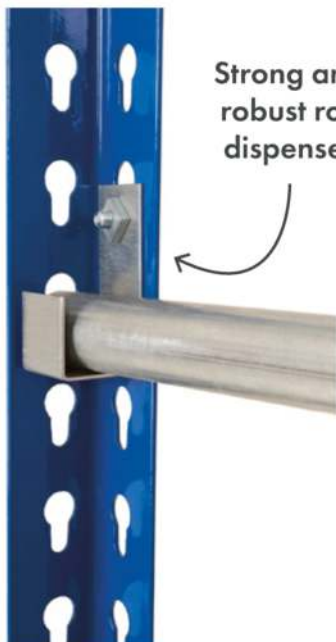

Strong and robust roll dispenser

Chipboard top



We Recommend!

See page 112 for racksack® mini



Available Sizes

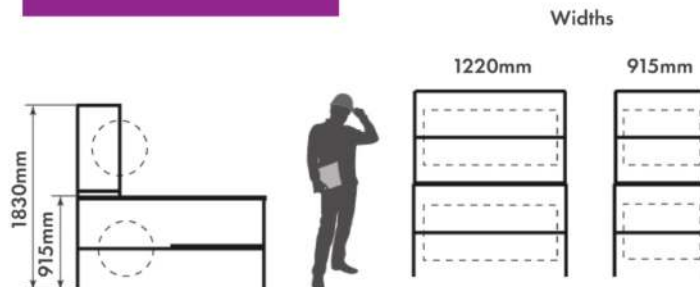

Long Rivet Packing Workstation

Ref	Size (h x w x d)	Colour
RRLPS09	1830mm x 915mm x 1830mm	Blue Uprights
RRLPS12	1830mm x 1220mm x 1830mm	Blue Uprights

➔ Order more workstations and save money.

SDL TEL: 01446772614 www.storage-design.ltd.uk info@storage-design.ltd.uk

Wide Rivet Packing Workstation

ANCO STORAGE

- ➔ Wide packing bench with lower bubble wrap dispenser and upper paper roll dispenser
- ➔ Cost-effective and easy to use
- ➔ Two width options available
- ➔ Includes upper and lower shelves for additional storage

Our Wide Rivet Packing Workstations come with an upper storage level for additional storage and, depending on the bench configuration, you get a lower storage level as well. Ideal for order processing, packing and manufacturing.

Each order includes uprights, plastic feet, all necessary beams, chipboard tops and 2 roll dispensers. All dispensers are simply and quickly lifted out to change the rolls.

Two width options available - 1525mm and 1830mm.



RRWPS18

**Capacity
Up to 300kg
Bench Load**

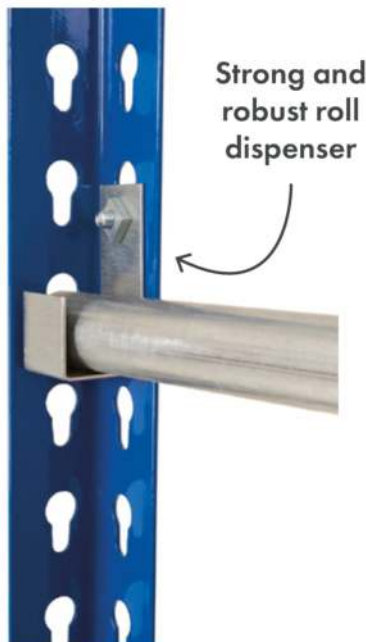

Strong and robust roll dispenser

Chipboard top



We Recommend!

See page 112 for racksack® mini



Available Sizes

Widths

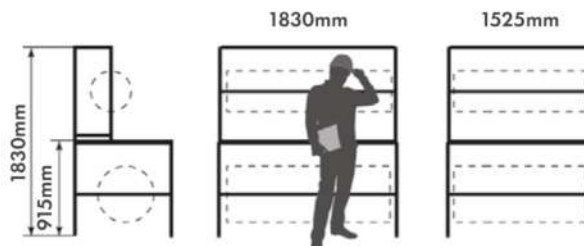

Wide Rivet Packing Workstation

Ref	Size (h x w x d)	Colour
RRWPS15	1830mm x 1525mm x 915mm	Blue Uprights
RRWPS18	1830mm x 1830mm x 915mm	Blue Uprights

➔ Order more workstations and save money.

Plastic Storage Bins



- ➔ Strong and robust plastic bins manufactured from shock proof plastic
- ➔ Easily identify contents
- ➔ Ideal for heavy duty industrial applications
- ➔ Available in 9 sizes and 3 colours
- ➔ Stack or hang on louvre panel
- ➔ Labels included with each bin

Plastic Storage Bins that can be used in any environment time and time again.

The quality and ergonomic design means all our plastic bin can be stacked securely or hung on louvre panels.

[Please see page 105 for Wall Louvre Kits.](#)

These bins are efficient in any small part picking environment. They have a large identification area as well as a large open picking face, meaning the contents can be easily identified and picked efficiently.

Available in 3 colour options, making them ideal for 5S and Lean environments.



We Recommend!

See page 105 for Wall Louvre Kits with Plastic Storage Bins



Reinforced sides to stop spreading

Plastic Storage Bins

Ref	Size (w x d x h)	Colour	Pack
ARTB05	106mm x 106mm x 49mm	Red, Blue, Yellow	24
ARTB10	106mm x 136mm x 76mm	Red, Blue, Yellow	24
ARTB20	106mm x 187mm x 76mm	Red, Blue, Yellow	24
ARTB25	140mm x 205mm x 127mm	Red, Blue, Yellow	20
ARTB30	140mm x 274mm x 127mm	Red, Blue, Yellow	20
ARTB35	210mm x 279mm x 179mm	Red, Blue, Yellow	20
ARTB40	210mm x 375mm x 179mm	Red, Blue, Yellow	10
ARTB50	280mm x 457mm x 254mm	Red, Blue, Yellow	6
ARTB60	415mm x 375mm x 179mm	Blue	5
ARTB70	415mm x 460mm x 292mm	Blue	3

➔ Please state colour required when ordering - (/R) Red, (/B) Blue and (/Y) Yellow.



➔ ARTB60 and ARTB70 is only available in Blue colour option.

Wall Louvre Kits with Plastic Storage Bins

- ➔ Keep small parts organised with this unique wall shelving system
- ➔ 16 plastic bin louvre kits available
- ➔ All kits come complete with storage bins, labels and steel louvre panels (fixings not supplied)
- ➔ Wall louvre panel - 915mm x 457mm
- ➔ 3 colour bin options to choose from

The ideal solution for mounting storage bins on the wall in the workplace.

Each louvre panel is manufactured from hard wearing galvanized steel and is 915mm high x 457mm wide.

Each kit is supplied as standard with the colour options shown for the plastic storage bins - please contact the sales office if you require different colours.

Wall Louvre Kits with Plastic Storage Bins

Ref	Bin Description
WallKit/AP	6 x ARTB30, 6 x ARTB40
WallKit/BP	8 x ARTB10, 12 x ARTB20, 9 x ARTB30
WallKit/CP	18 x ARTB30
WallKit/DP	36 x ARTB20
WallKit/EP	3 x ARTB25, 3 x ARTB30, 2 x ARTB40, 2 x ARTB60
WallKit/FP	8 x ARTB10, 8 x ARTB20, 6 x ARTB25, 6 x ARTB30
WallKit/GP	5 x ARTB60
WallKit/HP	10 x ARTB40
WallKit/JP	36 x ARTB05
WallKit/KP	36 x ARTB10
WallKit/LP	16 x ARTB10, 20 x ARTB20
WallKit/MP	18 x ARTB25
WallKit/NP	9 x ARTB25, 9 x ARTB30
WallKit/PP	4 x ARTB10, 4 x ARTB20, 3 x ARTB25, 3 x ARTB30, 2 x ARTB40, 1 x ARTB60
WallKit/QP	4 x ARTB40, 2 x ARTB60
WallKit/RP	3 x ARTB70

ANCO STORAGE



Wall Kit/AP



Wall Kit/BP



Wall Kit/CP



Wall Kit/DP



Wall Kit/EP



Wall Kit/FP



Wall Kit/GP



Wall Kit/HP



Wall Kit/JP



Wall Kit/KP



Wall Kit/LP



Wall Kit/MP



We Recommend!

See pages 28-31 for code labelling and printing

LU26G2



Wall Kit/NP



Wall Kit/PP



Wall Kit/QP



Wall Kit/RP



racksack® is the original waste segregation solution, simplifying what can sometimes be a complicated and laborious process to separate waste. This enables users to create a sustainable, tidier, safer, and more productive workplace. Not only this, but these clever recycling sacks don't encroach on valuable floor space which is often at a premium (especially in warehouses). With quality that's impossible to miss, you know when it's racksack®!



racksack®

- ➔ Easy collection of waste
- ➔ Easy to fix and easy to remove
- ➔ Helps improve waste segregation
- ➔ Hard-wearing and re-usable
- ➔ Made from strong, durable polyester
- ➔ Available in 8 standard text and symbol designs
- ➔ Other designs and special prints such as logos are available upon request

racksack® is the market-leading solution for waste segregation in the industrial work setting, providing a simple and cost-effective system that's easy to implement.

This innovative family of products will help you to be compliant with the current EU and UK waste segregation legislation.

Designed for most racking and shelving systems between 900mm and 1100mm, the racksack® saves valuable floor space and simplifies what can sometimes be a complicated and laborious recycling process, enabling you to create a tidier, safer and more productive workplace.

Made from strong, durable polyester that withstands the rigours of a busy industrial environment. The flexible method of 'S' hook fixings means the racksack® can be hung over or hooked onto any substrate.

Three strong handles are woven into the edge of the sack - one on each side for carrying and one on the base - so that the sack can be easily tilted from the base and emptied.

Available in 8 standard text and symbol designs, including a completely blank sack.

The racksack® family includes products that can be attached to warehouse racking, shelving, trolleys, roll cages, stillages, mobile steps and more.

Dimensions
1000mm x
920mm
(h x w)



We Recommend!

See page 110 for
Symbol-only Designs



■ racksack® blue - Text Designs

Ref	Size (h x w)	Pack
RSB1	1000mm x 920mm	1
RSB5	1000mm x 920mm	5
RSB10	1000mm x 920mm	10

➔ Please add the design code to the end of the reference when ordering: for example general waste design in Blue, pack of 5, would be RSB5/GW.



Handles at the sides and base are double stitched to tough woven polyester for increased durability.

Available in a range of standard text designs or you can customise your own...

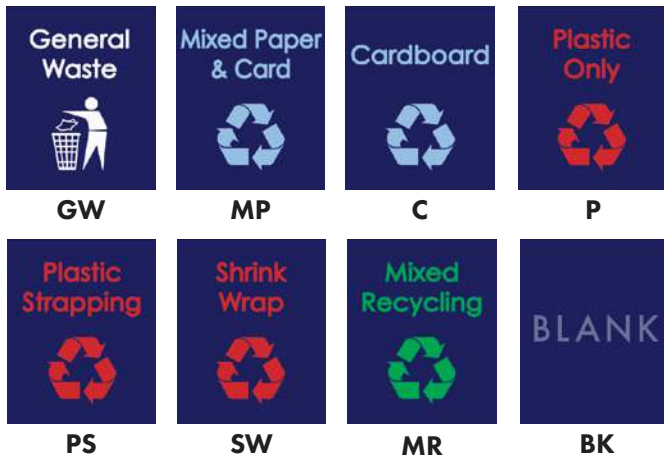

Other designs and special prints including logos are available on request. Customise your racksack® with your company name or logo, any waste product symbol or text you require and in any one colour print.

Brand your racksack®



Optional wall-mounted hooks for racksack® blue and racksack® clear. Ideal for easily hanging racksack® from walls. Sold in individual pairs.

Wall-mounted hook for racksack®

Ref	Size (h x w)	Pack
RSWP/1	80mm x 125mm	2

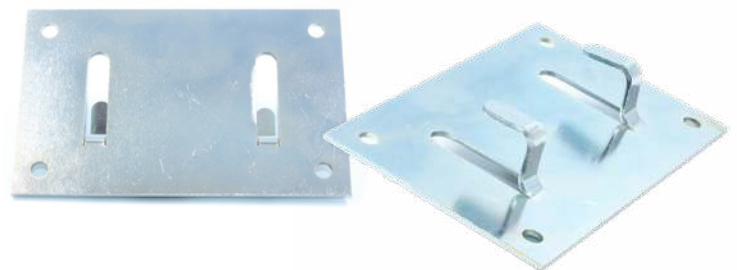

S Hooks

Ref	Pack
RSH1	10

Each sack is supplied with 2 fixing hooks as standard, however extra hooks can be purchased.



We Recommend!



See page 56 for Half Circle Floor Graphic Markers

racksack®

Designed to be recognised worldwide

- ➔ Symbol-only racksack® designs for worldwide use
- ➔ Choose from 5 popular designs
- ➔ Available in standard blue or premium clear
- ➔ Made from strong, durable polyester
- ➔ Other designs and special prints such as logos are available on request

By popular demand, we've created a symbol-only range of the racksack® that has been carefully designed with international recognition in mind. Visually communicative symbol-only designs, for worldwide use. These 5 waste segregation designs are also available in racksack® clear.

Choose from: Mixed Paper and Card, Cardboard Only, General Waste, Shrink Wrap and Plastic Only.

Customise your racksack® with your company name or logo, any waste product symbol or text you require, and in any one colour print. (Subject to minimum quantity).

■ racksack® blue - Symbol-only Designs

Ref	Size (h x w)	Pack
RSB1	1000mm x 920mm	1
RSB5	1000mm x 920mm	5
RSB10	1000mm x 920mm	10

➔ Please add the design code to the end of the reference when ordering, for example: cardboard only in symbol-only, pack of 5, would be RSB5/CNT.



MPNT - Mixed Paper and Card

Symbol-only designs available in standard blue or premium clear

Overall Dimensions
1000mm x 920mm (h x w)
Capacity 160 litres



racksack® clear

Overall Dimensions 1000mm x 920mm (h x w)
Capacity 160 litres

- ➔ Clearly see what materials are inside the racksack®
- ➔ Enhance security measures to prevent theft
- ➔ 10 standard waste designs available
- ➔ Premium clear front with blue backing
- ➔ Other designs and special prints such as logos are available upon request

The clear racksack® range gives warehouses the transparency they need when segregating waste and recycling. The premium clear material helps identify when incorrect waste has been placed into the wrong segregation sack.

The transparent design enhances security measures to help prevent theft.

Available in 10 of our popular standard designs - 5 text prints and 5 symbol-only prints.

racksack® clear

Ref	Size (h x w)	Pack
RSCL1	1000mm x 920mm	1
RSCL5	1000mm x 920mm	5
RSCL10	1000mm x 920mm	10

➔ Please add the design code to the end of the reference when ordering, for example: racksack® clear plastic only in text, pack of 10, would be RSC10/P.



racksack® mini

- ➔ Smaller racksack® designed for workstations and workbenches
- ➔ Ideal for packing benches; picking stations; assembly stations; desks; shelving and smaller racking areas
- ➔ Thanks to the new fastening options, you can also attach the racksack® to many different fixtures, such as pedestrian barriers and walls

Made from tough waterproof polyester, the racksack® mini can adequately withstand the rigours of an industrial environment. Three strong handles are woven into the edge of the sack, one on each side for carrying and one on the base, so the sack can be easily emptied.

Available in 4 text or 3 symbol only design options, including a blank option. Sold individually or in packs of 5 and 10. Fasten with the 'S' hook; the bungee loop or wall mounted hook.



**best
business**
AWARDS
Winner 2022
Best New Product / Service

Dimensions
880mm x 600mm
(h x w)

Capacity 70 litres

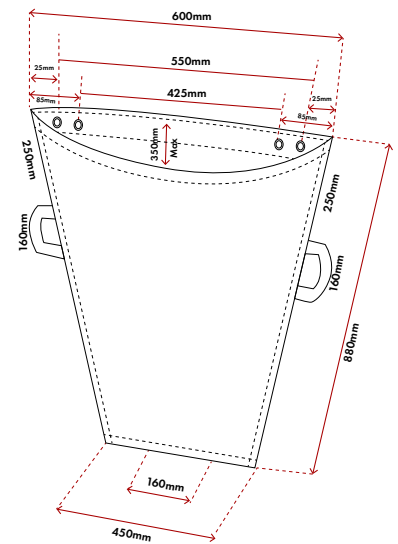

**best
business**
AWARDS
Winner 2022
Best New Product / Service



Available in a range of standard text and symbol-only designs



GW



MP



P



MR



GWNT



MPNT



PNT



BK

Perfect for:

- Packing stations
- Picking areas
- Shelving
- Offices
- Desks
- Assembly areas
- Workbenches and workstations

racksack® mini

Ref	Description	Pack
RSMB1	880mm high x 600mm wide	1
RSMB5	880mm high x 600mm wide	5
RSMB10	880mm high x 600mm wide	10
BU4-1	Bungee Fixing Loop	1 Pair
WMH-1	Wall Mounted Hook	1 Pair
WMH-5	Wall Mounted Hook	5 Pairs

➔ Please add the design code to the end of the reference when ordering, for example: plastic in symbol-only, 1 racksack® mini, would be RSMB1/PNT.

racksack® mini can be fixed in three ways:



2 Steel S Hooks

Supplied as standard



Bungee Loop



Wall Mounted Hook

racksack® nano

- ➔ Designed for use with forklift and pallet trucks
- ➔ Thanks to the new velcro fastening, any chance of snagging is eliminated
- ➔ Available in 3 text or 3 symbol-only design options, including a blank option
- ➔ Supplied with bungee loop fixing
- ➔ 600mm high x 450mm wide
- ➔ Other designs and special prints including logos are available on request

Introducing racksack® nano, based off direct customer feedback for an even more compact solution than racksack® mini!

This small and sturdy waste segregation sack is 600mm x 450mm, the perfect size to attach to forklift trucks and pallet truck handles, making it easy and convenient to collate waste materials on the move. Once full, racksack® nano can be emptied into a standard size racksack® or straight into the main waste collection point on site.

Featuring ties at the back and coming with bungee loop fixings as standard, racksack® nano is quick and easy to secure in place. Plus, to eliminate the possibility of snagging as the forklift or pallet truck moves around the warehouse, racksack® nano features a velcro fastening on the mouth, allowing it to be firmly closed.

Like the rest of the racksack® range, racksack® nano is available with various eye-catching designs on the front, making separation of waste materials a breeze.

racksack® nano promotes a cleaner and more organised workplace as it provides a place to deposit waste packaging while on the move – no more laborious to-ing and fro-ing from a standard floor bin!

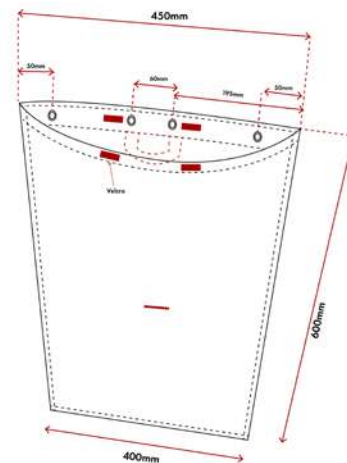
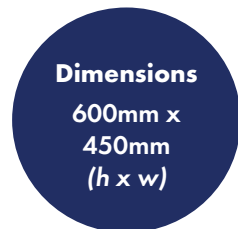
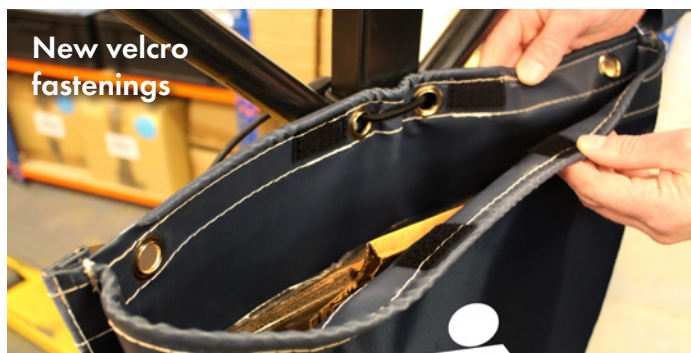

Capacity 32.8 litres





Available in a range of standard text and symbol-only designs

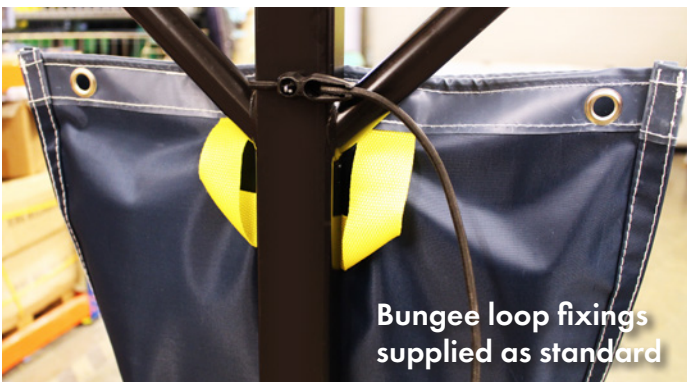

racksack® nano

Ref	Description	Pack
RSNB1	600mm high x 450mm wide	1
RSNB5	600mm high x 450mm wide	5
RSNB10	600mm high x 450mm wide	10
RSMB/HOOK	Small S Hooks	10

➔ Please add the design code to the end of the reference when ordering, for example: plastic in text, 5 racksack® nanos, would be RSNB5/P.

racksack® rollcage

- ➔ Organise waste packaging materials as you go
- ➔ Easy collection and segregation of waste
- ➔ Ideal for 800mm wide roll containers
- ➔ Hard-wearing and re-usable
- ➔ Can be overprinted for volume orders

Keep your workplace neat and tidy by fitting the racksack® rollcage, ideal for use on 800mm wide roll containers. Made from tough waterproof polyester, the large capacity twin pocket sacks can adequately withstand the rigours of an industrial environment.

Fits easily by hooking over the sides or can also be secured via eyelets in the top corners. Straps help secure the middle of the sack.



Overall Dimensions 1300mm x 880mm (h x w)
Capacity 200 litres

These recycling sacks are simple to hang and secure

Volume overprinting available - contact the sales office for details

■ racksack® rollcage - Double Pocket

Ref	Pocket Size (h x w)		Pack
	Upper	Lower	
C2B/1	700mm x 880mm	& 650mm x 880mm	1
C2B/5	700mm x 880mm	& 650mm x 880mm	5
C2B/10	700mm x 880mm	& 650mm x 880mm	10

➔ Capacity: Upper pocket - 108 Litres, Lower pocket - 95 Litres. Combined pockets when used together - 200 Litres.

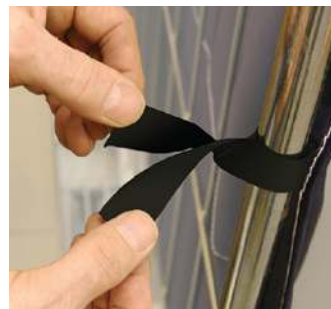

S Hooks

Ref	Pack
RSH1	10



Optional fixing hooks not supplied.

racksack® rollcage clear

- ➔ Organise waste packaging materials as you go
- ➔ Easy collection and segregation of waste
- ➔ Hard-wearing and re-usable
- ➔ Premium clear front with blue backing
- ➔ Enhances security measures
- ➔ Can be overprinted for volume orders

Keep your workplace neat and tidy by fitting the racksack® rollcage clear, ideal for use on 800mm wide roll containers.

Now available with a clear front, which helps identify when the sack is full and needs to be emptied. The racksack® rollcage clear makes it easier to segregate and recycle waste on the go.

Made from tough waterproof polyester, the large capacity twin pocket sacks can adequately withstand the rigours of an industrial environment.

Fits by hooking over the sides, or can be secured via eyelets in the top corners. Straps help secure the middle of the sack.



Dimensions
1300mm x 880mm
(h x w)

The premium clear material helps identify when the sack is full and needs to be emptied



■ racksack® rollcage clear - Double Pocket

Ref	Pocket Size (h x w)		Pack
	Upper	Lower	
C2CL/1	700mm x 880mm	& 650mm x 880mm	1
C2CL/5	700mm x 880mm	& 650mm x 880mm	5
C2CL/10	700mm x 880mm	& 650mm x 880mm	10

➔ Capacity: Upper pocket - 108 Litres, Lower pocket - 95 Litres. Combined pockets when used together - 200 Litres.

racksack® trolley



Double Pocket



Single Pocket

- ➔ Organise waste packaging materials as you go
- ➔ Easy collection and segregation of waste
- ➔ Easy to fix and easy to empty
- ➔ Hard-wearing and re-usable
- ➔ Single or Double pocket versions
- ➔ Can be overprinted for volume orders

Keep your picking areas clean and tidy as you go by fitting these trolley recycling sacks. Not only do you keep unwanted waste materials off the floor, but you also help segregate waste. Made from tough waterproof polyester, these Single or Double pocket trolley sacks can adequately withstand the rigours of an industrial environment.

Ideal for hooking onto handles of picking trolleys up to 580mm wide, or they can be secured via eyelets in other locations. Once full, simply take the sack to your main waste station and empty the pre-segregated waste.



Available in
Single or
Double Pocket
versions

■ racksack® trolley - Single Pocket

Ref	Pocket Size (h x w)	Pack
T1B/1	600mm x 600mm	1
T1B/5	600mm x 600mm	5
T1B/10	600mm x 600mm	10

➔ Capacity: Single pocket - 50 Litres.

■ racksack® trolley - Double Pocket

Ref	Pocket Size (h x w)		Pack
	Upper	Lower	
T2B/1	600mm x 600mm & 500mm x 600mm	1	
T2B/5	600mm x 600mm & 500mm x 600mm	5	
T2B/10	600mm x 600mm & 500mm x 600mm	10	

➔ Capacity: Inner pocket - 50 Litres, Outer pocket - 55 Litres. Combined pockets when used together: 73 Litres.

Overall Dimensions
750mm x 600mm (h x w)



1. These terms

1.1 What these terms cover. These are the terms and conditions on which we supply goods and services.

1.2 Why you should read them. Please read these terms carefully before you submit your order to us. These terms tell you who we are, how we will provide products to you, how you and we may change or end the contract, what to do if there is a problem and other important information.

1.3 Are you a business customer or a consumer? We have assumed that this catalogue will be used by business customers only and these terms apply to business customers only. If you are a consumer (i.e. an individual buying products for personal use and not in the course of your business, trade or profession) then please view our terms and conditions for consumers online at <https://www.beaverswood.co.uk/terms-conditions>.

1.4 This is our entire agreement with you. These terms constitute the entire agreement between us in relation to your purchase. You acknowledge that you have not relied on any statement, promise, representation, assurance or warranty made or given by or on behalf of us which is not set out in these terms and that you shall have no claim for innocent or negligent misrepresentation or negligent misstatement based on any statement in this agreement.

2. Information about us and how to contact us

2.1 Who we are. We are Beaverswood Supply Co. Limited a company registered in England and Wales. Our company registration number is 01784234 and our registered office is at Units 8-10 Metro Centre, Toutley Road, Wokingham, Berkshire, RG41 1QW. Our registered VAT number is 303311075.

2.2 How to contact us. You can contact us by telephoning our customer service team at 0118 979 6096 or by writing to us at sales@beaverswood.co.uk or Units 8-10 Metro Centre, Toutley Road, Wokingham, Berkshire RG41 1QW.

2.3 How we may contact you. If we have to contact you we will do so by telephone or by writing to you at the email address or postal address you provided to us in your order.

2.4 "Writing" includes emails. When we use the words "writing" or "written" in these terms, this includes emails.

3. Our contract with you

3.1 How we will accept your order. Our acceptance of your order will take place when we confirm acceptance of it by phone or in writing, at which point a contract will come into existence between you and us.

3.2 If we cannot accept your order. If we are unable to accept your order, we will inform you of this and will not charge you for the product. This might be because the product is out of stock, because of unexpected limits on our resources which we could not reasonably plan for, because a credit reference we have obtained for you does not meet our minimum requirements, because we have identified an error in the price or description of the product or because we are unable to meet a delivery deadline you have specified. Furthermore, if you have requested installation services, we reserve the right to refuse your order if a site inspection or other factors reveal unexpected conditions.

3.3 Your order number. We will assign an order number to your order and tell you what it is when we accept your order. It will help us if you can tell us the order number whenever you contact us about your order.

4. Our products

4.1 Products may vary slightly from their pictures. The images of the products on our website and in our catalogue are for illustrative purposes only. Although we have made every effort to display the colours accurately, we cannot guarantee that a device's display of the colours or a picture in our catalogue accurately reflects the colour of the products. Your product may vary slightly from those images.

4.2 Product packaging may vary. The packaging of the product may vary from that shown in images on our website.

4.3 Making sure your measurements are accurate. If we are making the product to measurements you have given us you are responsible for ensuring that these measurements are correct.

5. Your rights to make changes

If you wish to make a change to the product you have ordered please contact us. We will let you know if the change is possible. If it is possible we will let you know about any changes to the price of the product, the timing of supply or anything else which would be necessary as a result of your requested change and ask you to confirm whether you wish to go ahead with the change. Please note, however, that we are unable to make any changes to non-standard products which are being made to your specification once you have ordered them.

6. Our rights to make changes

6.1 Minor changes to the products. We may change the product:

- to reflect changes in relevant laws and regulatory requirements; and
- to implement minor technical adjustments and improvements. These changes will not affect your use of the product.

7. Providing the products

7.1 Delivery costs. Delivery costs are variable depending on weight and location. Delivery costs will be as set out in our catalogue or as otherwise told to you during the ordering process.

7.2 When we will provide the products.

- If you have not requested installation services from us, we will deliver the products to you as soon as reasonably possible. We offer a next day delivery service on certain standard 'off-the-shelf' products. If you place your order before 3pm on a working day, we will use our reasonable efforts to deliver the products the next working day, however, delivery times are estimates only.
- If you have requested installation services from us, we will deliver the products and begin the installation services on the date agreed with you during the order process.

7.3 We are not responsible for delays outside our control. If our supply of the products is delayed by an event outside our control then we will contact you as soon as possible to let you know and we will take steps to minimise the effect of the delay. Provided we do this we will not be liable for delays caused by the event, but if there is a risk of substantial delay you may contact us to end the contract and receive a refund for any products you have paid for but not received.

7.4 If you are not at the delivery location when the product is delivered. If no one is available at your address to take delivery and the products cannot be posted through a letterbox, we will leave you a note informing you of how to rearrange delivery or collect the products from a local depot.

7.5 If you do not re-arrange delivery. If you do not collect the products from us as arranged or if, after a failed delivery to you, you do not re-arrange delivery or collect them from a delivery depot we will contact you for further instructions and may charge you for storage costs and any further delivery costs. If, despite our reasonable efforts, we are unable to contact you or re-arrange delivery or collection we may end the contract and clause 10.2 will apply.

7.6 If you do not allow us access to provide services. We require unobstructed access to the installation site between 8.00 a.m. to 6.00 p.m. each working day of installation. If you do not allow us access to the site to perform the services as arranged (and you do not have a good reason for this) we may charge you additional costs incurred by us as a result. If, despite our reasonable efforts, we are unable to contact you or re-arrange access to the site we may end the contract and clause 10.2 will apply.

7.7 We require a project manager for installation services. If you have paid for installation services, we require a named project manager available to resolve any problems that may arise during the entire installation period.

7.8 Health and safety requirements for installation services. We need to be advised of all health and safety requirements at your premises two weeks prior to the installation date.

7.9 Cold store conditions. In cold store installations, you must provide suitable clothing for the installers, failing which we may refuse to carry out the installation.

7.10 When you become responsible for the goods. The products will be your responsibility from the time we deliver them to the address you gave us.

7.11 When you own goods. You own a product once we have received payment in full (in cash or cleared funds) for all products and services ordered by you from us.

7.12 What will happen if you do not give required information to us. We may need certain information from you so that we can supply the products to you, for example, a specification of the products required. If so, this will have been stated in the description of the products on our website. We will contact you to ask for this information. If you do not give us this information within a reasonable time of us asking for it, or if you give us incomplete or incorrect information, we may either end the contract (and clause 10.2 will apply) or make an additional charge of a reasonable sum to compensate us for any extra work that is required as a result. We will not be responsible for supplying the products late or not supplying any part of them if this is caused by you not giving us the information we need within a reasonable time of us asking for it.

7.13 Reasons we may suspend the supply of products to you. We may have to suspend the supply of a product to:

- deal with technical problems or make minor technical changes;
- update the product to reflect changes in relevant laws and regulatory requirements;
- make changes to the product as requested by you or notified by us to you (see clauses 5 and 6).

7.14 Your rights if we suspend the supply of products. We will contact you in advance to tell you we will be suspending supply of the product, unless the problem is urgent or an emergency. You may contact us to end the contract for a product if we suspend it, or tell you we are going to suspend it, in each case for a period of more than 30 days and we will refund any sums you have paid in advance for the product in respect of the period after you end the contract.

7.15 We may also suspend supply of the products if you do not pay. If you do not pay us for the products when you are supposed to (see clause 12.3) and you still do not make payment within 14 days of us reminding you that payment is due, we may suspend supply of all products until you have paid us the outstanding amounts. We will contact you to tell you we are suspending supply of products. We will not suspend the products where you dispute the unpaid invoice (see clause 12.6). As well as suspending the products we can also charge you interest on your overdue payments (see clause 12.5).

8. Your rights to end the contract

8.1 Exercising your right to change your mind. For most products bought via our catalogue we will allow you to return the goods and receive a refund if you have ordered the wrong product or you have changed your mind within 14 days after you receive the product, provided that the product is still, in our reasonable opinion, in a resalable condition.

8.2 When you do not have a right to a refund. Your right to a refund does not apply in respect of:

- non-standard products which have been made to your specification;
- services, once these have been completed, even if the cancellation period is still running; and
- any products which become mixed inseparably with other items after their delivery.

9. How to end the contract with us

9.1 Returning products. If you want to return any products after they have been dispatched to you or you have received them, you must return them to us. You must either return the goods in person to where you bought them or post

them back to us at Units 8-10 Metro Centre, Toutley Road, Wokingham, Berkshire, RG41 1QW.

9.2 When we will pay the costs of return. We will pay the costs of return:

- if the products are faulty or misdescribed;
- if we have told you about an error in pricing or description, or because you have a legal right to do so as a result of something we have done wrong.

In all other circumstances you must pay the costs of return.

9.3 How we will refund you. If you are entitled to a refund under these terms we will refund you the price you paid for the products including delivery costs, by the method you used for payment. However, we may make deductions from the price, as described below.

9.4 When we may make deduction from refunds. If you are exercising your right to change your mind:

- We will charge a handling fee of 12.5% of the price of the returned product and deduct this from your refund. If we refund you the price paid before we are able to inspect the goods and later discover you have handled them in an unacceptable way, you must pay us an appropriate amount.
- The maximum refund for delivery costs will be the costs of delivery by the least expensive delivery method we offer. For example, if we offer delivery of a product within 3-5 days at one cost but you choose to have the product delivered within 24 hours at a higher cost, then we will only refund what you would have paid for the cheaper delivery option.
- Where the product is a service, we may deduct from any refund an amount for the supply of the service for the period for which it was supplied, ending with the time when you told us you had changed your mind.

The amount will be in proportion to what has been supplied, in comparison with the full coverage of the contract.

10. Our rights to end the contract

10.1 We may end the contract if you break it. We may end the contract for a product at any time by writing to you if:

- you do not make any payment to us when it is due and you still do not make payment within 14 days of us reminding you that payment is due;
- you do not, within a reasonable time of us asking for it, provide us with information that is necessary for us to provide the products;
- you do not, within a reasonable time, allow us to deliver the products to you or collect them from us;
- you do not, within a reasonable time, allow us access to your premises to supply the services;
- in the case of installation services, if a site inspection or other factors relating to your premises reveal unexpected conditions which would not be suitable for us to work in.

10.2 You must compensate us if you break the contract. If we end the contract in the situations set out in clause 10.1 we will refund any money you have paid in advance for products we have not provided but we may deduct or charge you reasonable compensation for the net costs we will incur as a result of your breaking the contract.

11. Your rights in respect of defective products

11.1 We warrant that, on delivery, any products which are goods will conform in all material respects with their description and any relevant specification, and for a period of 12 months from the date of delivery (warranty period), shall:

- be free from material defects in design, material and workmanship;
- be of satisfactory quality (within the meaning of the Sale of Goods Act 1979); and
- be fit for any purpose held out by us.

11.2 Subject to clause 11.3, if:

- you give us notice in writing on delivery that the products do not conform in all material respects with their description and any relevant specification or during the warranty period within a reasonable time of discovery that a product does not comply with the other warranties set out in clause 11.1 (a) – (c);
- we are given a reasonable opportunity of examining such product; and
- you return such product to us at your cost,

we shall, at our option, repair or replace the defective product, or refund the price of the defective product in full.

11.3 We will not be liable for a product's failure to comply with the warranty in clause 11.1 if:

- you make any further use of such product after giving a notice in accordance with clause 11.2(a);
- the defect arises because you failed to follow our oral or written instructions as to the storage, installation, commissioning, use or maintenance of the product or (if there are none) good trade practice;
- the defect arises as a result of us following any drawing, design or specification supplied by you;
- you alter or repair the product without our written consent; or
- the defect arises as a result of fair wear and tear, wilful damage, negligence, or abnormal working conditions.

11.4 Except as provided in this clause 11, we shall have no liability to you in respect of a product's failure to comply with the warranty set out in clause 11.1.

11.5 These terms shall apply to any repaired or replacement products supplied by us under clause 11.2.

12. Price and payment

12.1 Where to find the price for the product. The price of the product (which excludes VAT) will be the price set out in our catalogue, as indicated on the order pages of our website when you placed your order, or as otherwise told to you during the ordering process.

12.2 We will pass on changes in the rate of VAT. If the rate of VAT changes between your order date and the date we supply the product, we will adjust the rate of VAT that you pay, unless you have already paid for the product in full before the change in the rate of VAT takes effect.

12.3 When you must pay and how you must pay. We accept payment with most major credit cards. When you must pay depends on what product you are buying and whether or not you are a credit customer:

- For goods, you must pay for the products before we dispatch them (unless you are a credit customer, in which case see clause 12.3(c) below).
- For services, we will invoice you for the price of the services when we have completed them. You must pay each invoice within 30 calendar days after the date of the invoice.
- If you are a credit customer. If you are a regular credit customer and we have offered for you to open up an account with us then we will invoice you for the goods when we have dispatched them. You must pay each invoice within 30 calendar days after the date of the invoice.

12.4 Our right of set-off. You must pay all amounts due to us under these terms in full without any set-off, counterclaim, deduction or withholding (other than any deduction or withholding of tax as required by law).

12.5 We can charge interest if you pay late. If you do not make any payment to us by the due date we may charge interest to you on the overdue amount at the rate of 4% a year above the base lending rate of the Bank of England from time to time. This interest shall accrue on a daily basis from the due date until the date of actual payment of the overdue amount, whether before or after judgment. You must pay us interest together with any overdue amount.

12.6 What to do if you think an invoice is wrong. If you think an invoice is wrong please contact us promptly to let us know. You will not have to pay any interest until the dispute is resolved. Once the dispute is resolved we will charge you interest on correctly invoiced sums from the original due date.

13. Our responsibility for loss or damage suffered by you

13.1 Nothing in these terms shall limit or exclude our liability for:

- death or personal injury caused by our negligence, or the negligence of our employees, agents or subcontractors (as applicable);
- fraud or fraudulent misrepresentation;
- breach of the terms implied by section 12 of the Sale of Goods Act 1979 or section 2 of the Supply of Goods and Services Act 1982; or
- defective products under the Consumer Protection Act 1987; or
- any matter in respect of which it would be unlawful for us to exclude or restrict liability.

13.2 Except to the extent expressly stated in clause 11.1 all terms implied by sections 13 to 15 of the Sale of Goods Act 1979 and sections 3 to 5 of the Supply of Goods and Services Act 1982 are excluded.

13.3 Subject to clause 13.1:

- we shall not be liable to you, whether in contract, tort (including negligence), breach of statutory duty, or otherwise, for any loss of profit, or any indirect or consequential loss arising under or in connection with any contract between us; and
- our total liability to you for all other losses arising under or in connection with any contract between us, whether in contract, tort (including negligence), breach of statutory duty, or otherwise, shall be limited to the total sums paid by you for products under such contract.

13.4 How we may use your personal information. We will only use your personal information as set out in our Privacy Policy. You can find our Privacy Policy on our website.

14. Other important terms

14.1 Nobody else has any rights under this contract (except someone you pass your guarantee on to). This contract is between you and us. No other person shall have any rights to enforce any of its terms.

14.2 If a court finds part of this contract illegal, the rest will continue in force. Each of the paragraphs of these terms operates separately. If any court or relevant authority decides that any of them are unlawful, the remaining paragraphs will remain in full force and effect.

14.3 Even if we delay in enforcing this contract, we can still enforce it later. If we do not insist immediately that you do anything you are required to do under these terms, or if we delay in taking steps against you in respect of your breaking this contract, that will not mean that you do not have to do those things and it will not prevent us taking steps against you at a later date. For example, if you miss a payment and we do not chase you but we continue to provide the products, we can still require you to make the payment at a later date.

14.4 Which laws apply to this contract and where you may bring legal proceedings if you are a business. If you are a business, any dispute or claim arising out of or in connection with a contract between us or its subject matter or formation (including non-contractual disputes or claims) shall be governed by and construed in accordance with the law of England and Wales and the courts of England and Wales shall have exclusive jurisdiction to settle any such dispute or claim.

EST. 1984

BEAVERSWOOD®

making the workplace work smarter

part of **IWS GROUP**
the Industrial Workspace Specialists



STORAGE DESIGN LIMITED
Tel: 01446 772614
email: info@storage-design.ltd.uk
web: www.storage-design.ltd.uk

