



# AUTOPRIME

## QI 200 - 200mm Enclosed Automatic Priming Pump

The SPP AUTOPRIME QI200 pump is a fully enclosed diesel driven pump unit with high efficiency, designed to pump most liquids including sewage and semi solids. The enclosure provides sound reduction and security for use in noise sensitive areas. Typical uses are removal of ground and rain water from excavations, trenches, footings, manholes and ponds etc. May also be used for stream and pipe diversions and flood water control, well point dewatering, pipe relining and sludge pumping.



### DESIGN FEATURES

- Bundled unit on two wheel road trailer with fixed height towing eye or 50mm ball hitch.
- Alternative trailer for the QI200 with variable height draw bar is available (adds 35 kg to weight).
- 12 volt battery starting by key switch with optional automatic start/stop facility.
- Pump will pass solids up to 75mm diameter and 90mm long.
- Reliable double mechanical seals which allow dry running.
- Pump can be left running when liquid is exhausted and will prime automatically when liquid is present.
- Rugged construction requires minimal operator maintenance.
- 65 cfm Vacuum Pump with coalescer and air filtered before exhaust to atmosphere.
- Features efficient 'Smartprime' technology for energy saving and reliability.

### PUMP SPECIFICATIONS

Flow Rate	570 m <sup>3</sup> /h Maximum
Discharge Head	35 m Maximum
Working Pressure	10 bar Maximum
Suction Hose Size	200 mm (8 in) Dia.
Discharge Hose Size	200 mm (8 in) Dia.
Max Solids Size	75 mm Diameter x 90 mm
Pump Casing	Cast Iron
Impeller	SG Iron
Pump Shaft	Stainless Steel
Wear Plates	SG Iron
Suction Sump	Cast Iron

Shaft Seal	Silicon Carbide/Silicon Carbide	
Elastomer	Viton	
Diesel Engine	Isuzu 4LE1 Water Cooled	
Power Rating	19.1kW @1500 & 25.9kW @2000	
Starting	12 Volt Battery by Key Switch	
Sound Pressure	72 dBA at 7 metres	
Fuel Tank Capacity	220 litres	
Full Load Consumption	6.7 litres / hour average	
Full Load Running Time	33 hours	
Chassis Options	Skid or as a Pod for mounting	
Weight With Fuel	Fixed Height Drawbar 1432kg	

Specifications may be subject to change without notice.

QI200rev02 Trailers

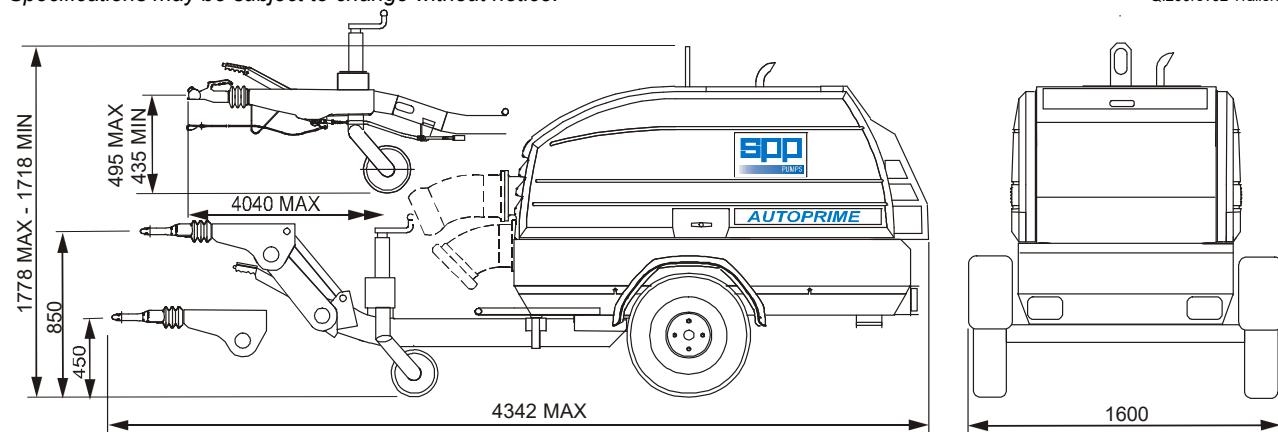



# AUTOPRIME

QI 200x ISUZU 4LE1

Curve Ref: QI 200-4LE1-v6  
Speed: see below (rpm)  
Suct x Disch: 8 in x 8 in

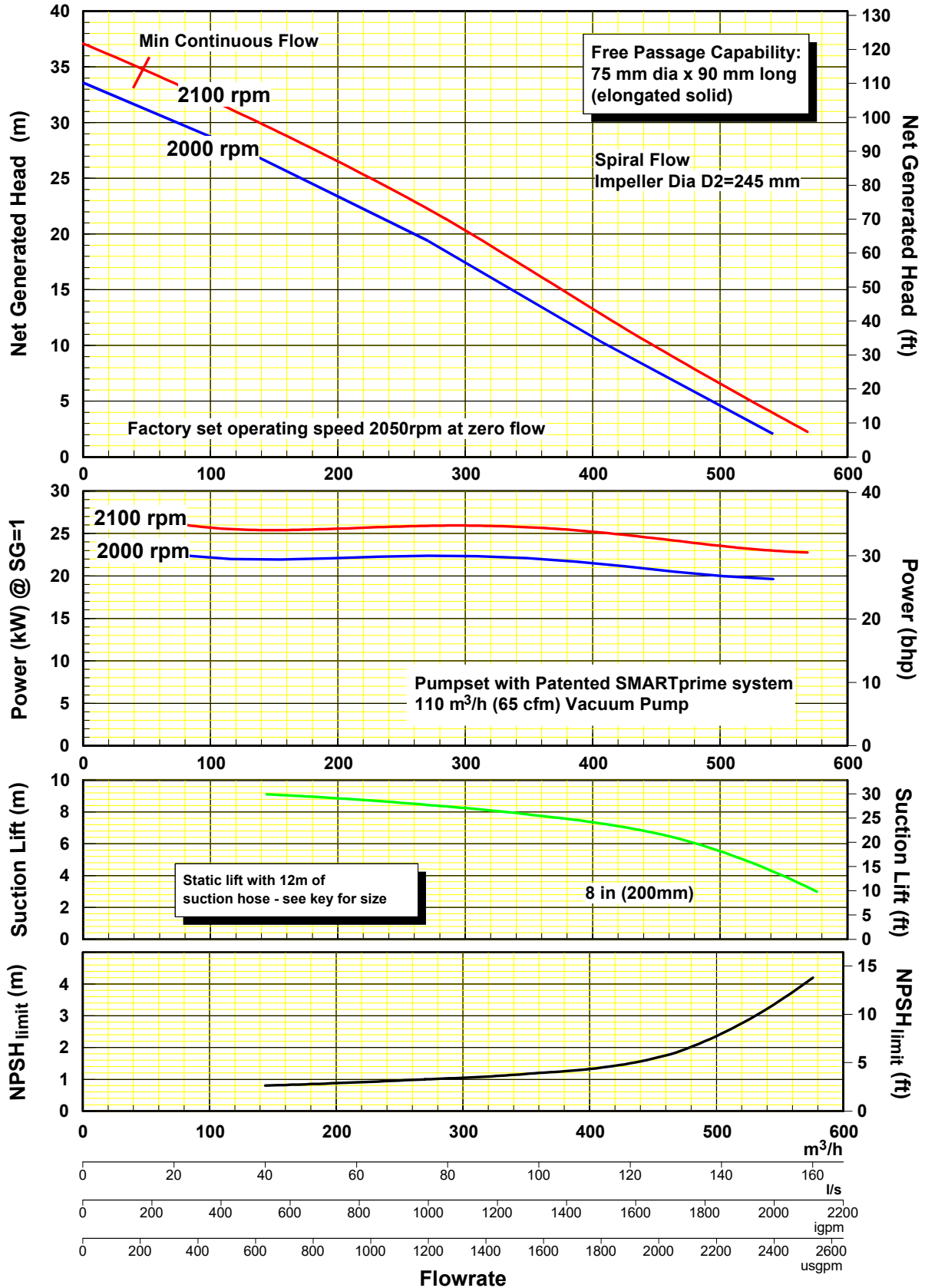

SOLD BY



info@aquosis.com  
1.877.907.7852