



Pictured: JULIET2-L Plus Gable Roof & Patio

Home Technology Club

Modular Series

Container Homes

For more information, call (02) 4545 2599 or visit online at www.hometechclub.au

JULIET Series

Modular Container Units



What Sizes Are Available:

Designed for flexibility, the JULIET Series connects via a simple clamp system to form anything from compact spaces to expansive multi-room layouts. Available in Standard (S), Large (L), and Extra Large (XL), each unit offers the same premium build and smart design for any space.



How many can i join together?

Our JULIET large and extra large modules can be joined in countless configurations, from single units to expansive layouts. Custom interior and exterior design options ensure each setup fits your site and lifestyle needs.

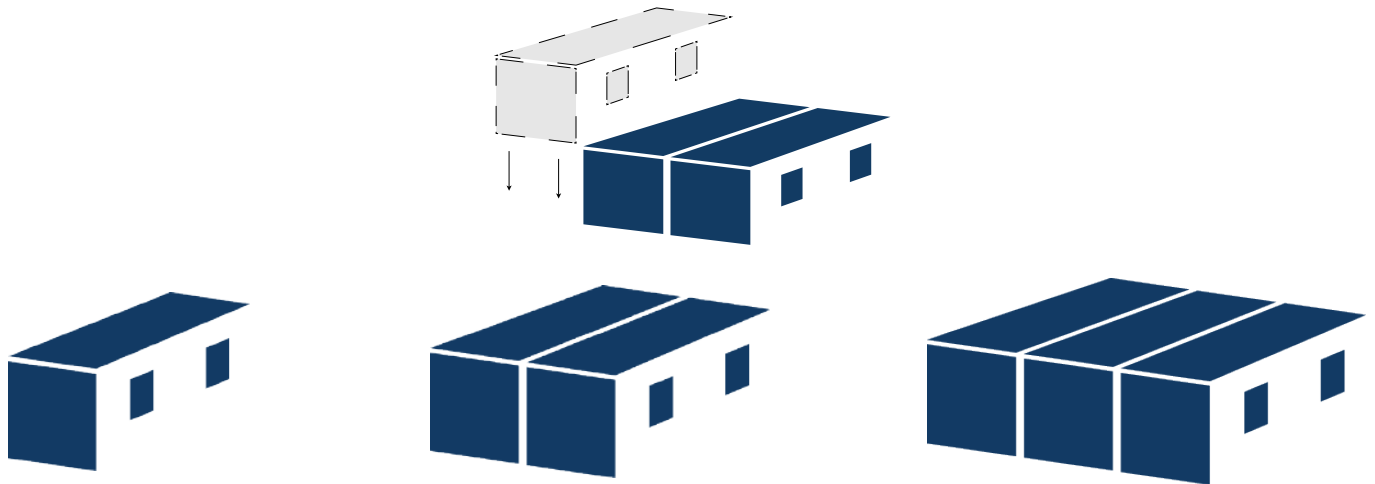

Each JULIET model number reflects the number of connected modules, for example JULIET1L is a single standalone unit, JULIET2L joins two units, and the series continues from there.

JULIET-1-Studio

One 6m x 2.4m Unit - Totaling 14.4m² Externally



Pictured: Custom JULIET1-S-Classic



Base Unit

13.1m²
Internal 2.4m (W) x 6m (L) x 2.7m (H)

- ✓ Empty Unit Ready For Your Customisations
- ✓ Vinyl Flooring
- ✓ Australian Standard Electrical
- ✓ 2x Double Glazed Windows
- ✓ 6x LED Down-lights
- ✓ 2x Double Power Points
- ✓ Steel Swing Door

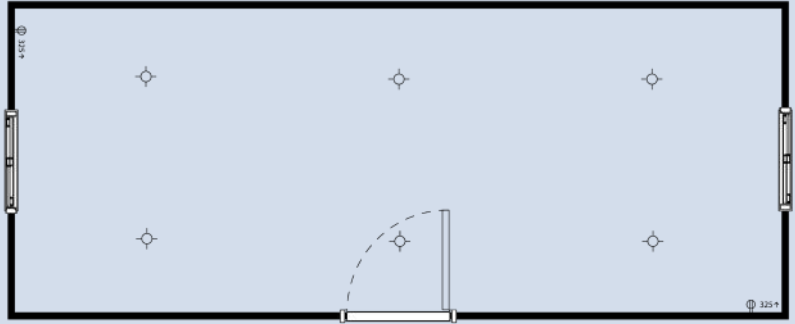

Classic Unit

 Studio  1  1 **13.1m²**
Internal 2.4m (W) x 6m (L) x 2.7m (H)

- ✓ Small Kitchenette (Excl. Appliances)
- ✓ Classic Bathroom (With Shower Curtain)
- ✓ Vinyl Flooring
- ✓ Australian Standard Plumbing & Electrical
- ✓ 2x Double Glazed Windows
- ✓ 6x LED Down-lights
- ✓ 5x Double Power Points
- ✓ Glass Sliding Door

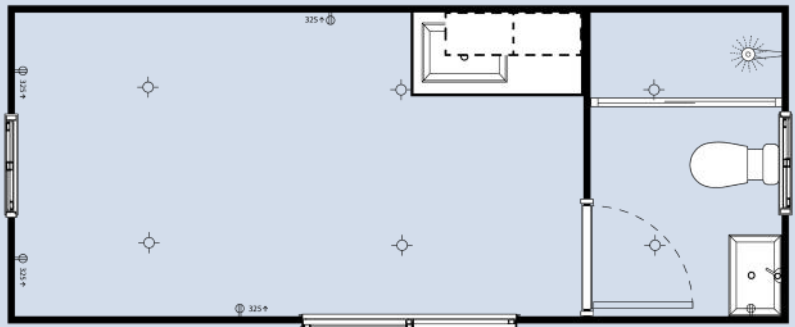

Premium Unit

 Studio  1  1 **13.1m²**
Internal 2.4m (W) x 6m (L) x 2.7m (H)

- ✓ Full L-Shape Kitchen (Incl. Appliances)
- ✓ Premium Bathroom (With Glass Shower Screen)
- ✓ Tiled Flooring & Bathroom Walls
- ✓ Australian Standard Plumbing & Electrical
- ✓ 2x Double Glazed Windows
- ✓ 6x LED Down-lights
- ✓ 6x Double Power Points
- ✓ Glass Sliding Door
- ✓ Air-conditioning

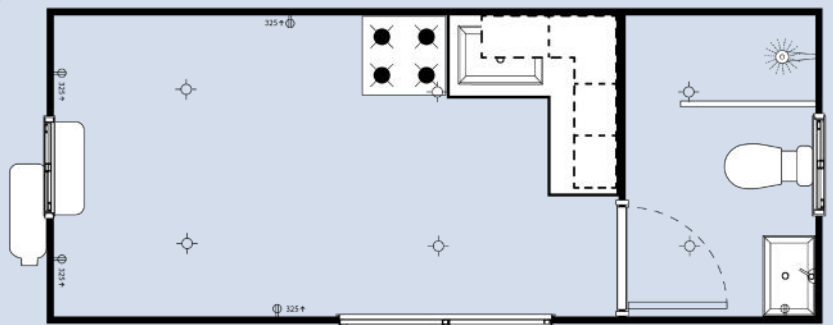

JULIET-1-L

One 6m x 3m Unit - Totaling 18m² Externally



Pictured: JULIET1-L-Classic

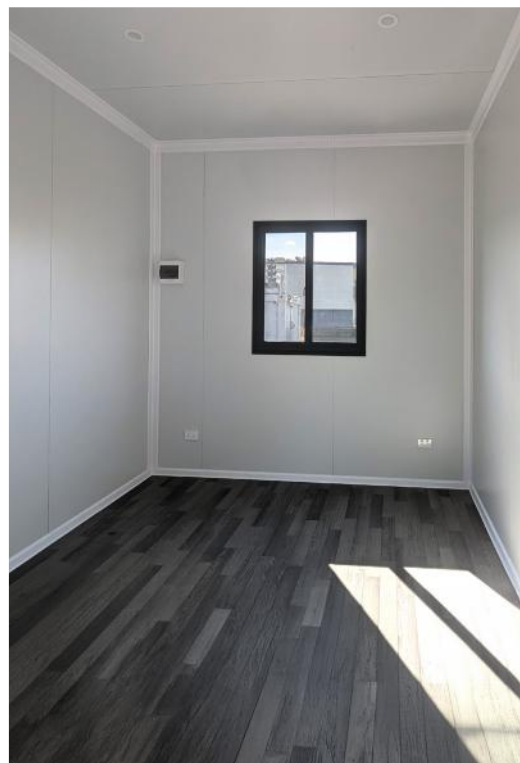

Base Unit

16.6m²
Internal 3m (W) x 6m (L) x 3.0m (H)

- ✓ Empty Unit Ready For Your Customisations
- ✓ Vinyl Flooring
- ✓ Australian Standard Electrical
- ✓ 2x Double Glazed Windows
- ✓ 8x LED Down-lights
- ✓ 2x Double Power Points
- ✓ Steel Swing Door

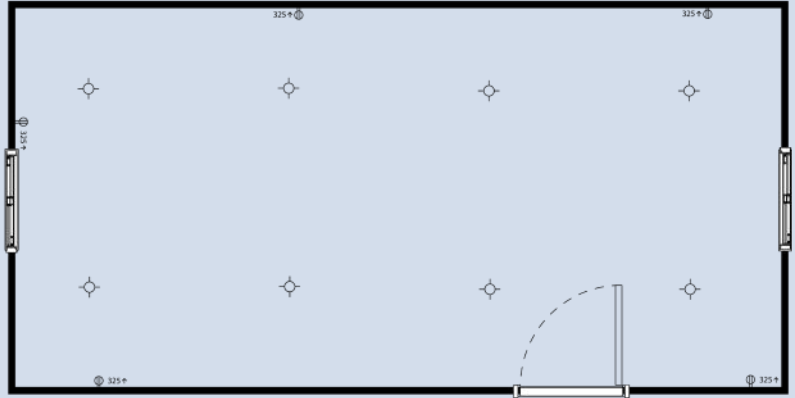

Classic Unit

16.6m²
Internal 3m (W) x 6m (L) x 3.0m (H)

- ✓ Small Kitchenette (Excl. Appliances)
- ✓ Classic Bathroom (Tiled Floor and Shower Only)
- ✓ Australian Standard Plumbing & Electrical
- ✓ 2x Double Glazed Windows
- ✓ 8x LED Down-lights
- ✓ 5x Double Power Points
- ✓ Glass Sliding Door

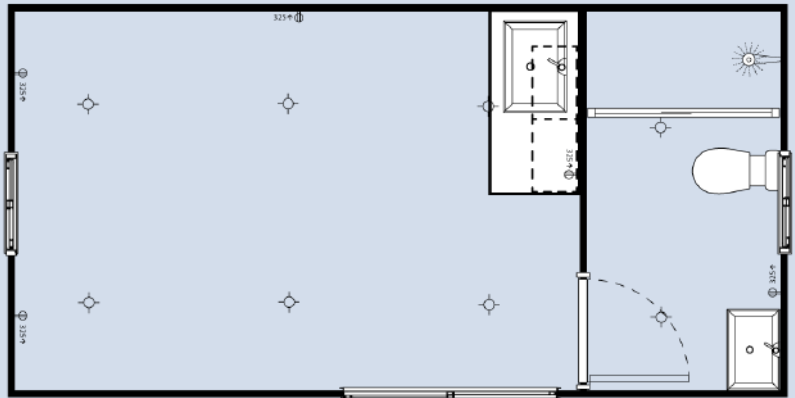

Premium Unit

16.6m²
Internal 3m (W) x 6m (L) x 3.0m (H)

- ✓ Full L-Shape Kitchen (Incl. Appliances)
- ✓ Premium Bathroom (Floor To Ceiling Tiles)
- ✓ Australian Standard Plumbing & Electrical
- ✓ 2x Double Glazed Windows
- ✓ 8x LED Down-lights
- ✓ 9x Double Power Points
- ✓ Glass Sliding Door
- ✓ Air-Conditioning

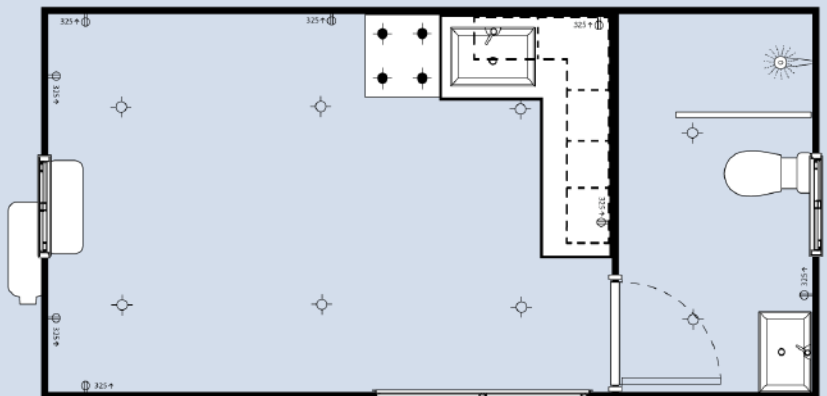

JULIET-2-L

Two 6m x 3m Units - Totaling 36m² Externally



Pictured: JULIET2-L-Classic Plus Veranda



Base Unit

34.2m²
Internal 6m (W) x 6m (L) x 3.0m (H)

- ✓ Empty Unit Ready For Your Customisations
- ✓ Vinyl Flooring
- ✓ Australian Standard Electrical
- ✓ 3x Double Glazed Windows
- ✓ 12x LED Down-lights
- ✓ 4x Double Power Points
- ✓ Steel Swing Door

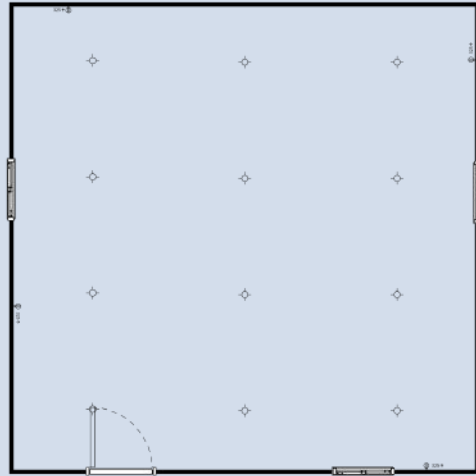

Classic Unit

 1 or 2  1  1 **34.2m²**
Internal 6m (W) x 6m (L) x 3.0m (H)

- ✓ 1 or 2 Bedrooms (With built-in wardrobes)
- ✓ Full L-Shape Kitchen (Incl. Appliances)
- ✓ Classic Bathroom (Tiled Floor and Shower Only)
- ✓ Laundry Sink and Room For A Washer (In Bathroom)
- ✓ Australian Standard Plumbing & Electrical
- ✓ 3x Double Glazed Windows
- ✓ 12x LED Down-lights
- ✓ 8x Double Power Points
- ✓ Glass Sliding Door

1 Bed Layout



2 Bed Layout



Premium Unit

 1 or 2  1  1 **34.2m²**
Internal 6m (W) x 6m (L) x 3.0m (H)

- ✓ 1 or 2 Bedrooms (With built-in wardrobes)
- ✓ Full Kitchen (Incl. Appliances)
- ✓ Premium Bathroom (Tiled Floor and Walls)
- ✓ Laundry Sink and Room For A Washer (In Bathroom)
- ✓ Australian Standard Plumbing & Electrical
- ✓ 3x Double Glazed Windows
- ✓ 12x LED Down-lights
- ✓ 8x Double Power Points
- ✓ Glass Sliding Door

1 Bed Layout



2 Bed Layout



JULIET-3-L

Three 6m x 3m Units - Totaling 54m² Externally



Pictured: JULIET3-L-Classic Plus Veranda



Base Unit

51.7m²
Internal 9m (W) x 6m (L) x 3.0m (H)

- ✓ Empty Unit Ready For Your Customisations
- ✓ Vinyl Flooring
- ✓ Australian Standard Electrical
- ✓ 4x Double Glazed Windows
- ✓ 12x LED Down-lights
- ✓ 4x Double Power Points
- ✓ Steel Swing Door

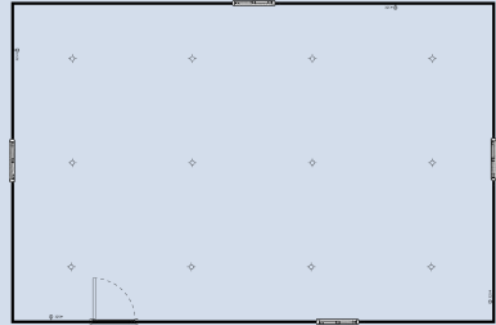

Classic Unit

1 or 2 1 1 51.7m²
Internal 9m (W) x 6m (L) x 3.0m (H)

- ✓ 1 or 2 Bedrooms (With built-in wardrobes)
- ✓ Full L-Shape Kitchen (Incl. Appliances)
- ✓ Classic Bathroom (Tiled Floor and Shower Only)
- ✓ Laundry Sink and Room For A Washer (In Bathroom)
- ✓ Australian Standard Plumbing & Electrical
- ✓ 13x LED Down-lights
- ✓ 10x Double Power Points
- ✓ Glass Sliding Door
- ✓ 5x Double Glazed Windows (1 bed)
- ✓ 6x Double Glazed Windows (2 bed)

1 Bed Layout

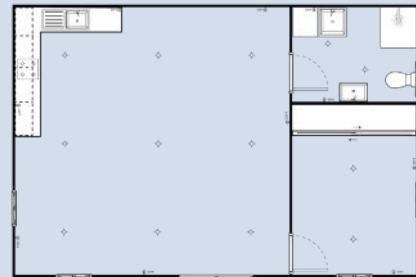

2 Bed Layout

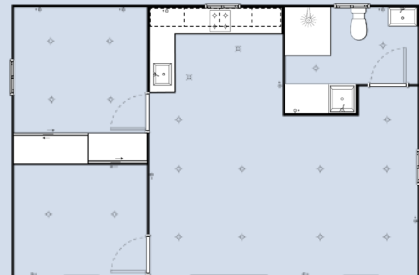

Premium Unit

1 or 2 1 1 51.7m²
Internal 9m (W) x 6m (L) x 3.0m (H)

- ✓ 1 or 2 Bedrooms (With built-in wardrobes)
- ✓ Full U-Shape Kitchen (Incl. Appliances)
- ✓ Premium Bathroom (Tiled Floor and Walls)
- ✓ Laundry Sink and Room For A Washer (In Bathroom)
- ✓ Australian Standard Plumbing & Electrical
- ✓ 20x LED Down-lights
- ✓ 10x Double Power Points
- ✓ Glass Sliding Door
- ✓ 5x Double Glazed Windows (1 bed)
- ✓ 6x Double Glazed Windows (2 bed)

1 Bed Layout



2 Bed Layout

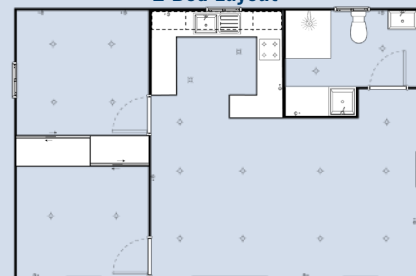

JULIET-1-XL

One 7.9m x 3m Unit - Totaling 23.7m² Externally



Pictured: JULIET1-XL-Motel



Classic Unit

Studio 1 1 **22m² Internal** 3m (W) x 7.9m (L) x 3.0m (H)

- ✓ Small Kitchenette (Excl. Appliances)
- ✓ Classic Bathroom (Tiled Floor and Shower Only)
- ✓ Australian Standard Plumbing & Electrical
- ✓ 8x LED Down-lights
- ✓ 6x Double Power Points
- ✓ Steel Swing Door
- ✓ 2x Double Glazed Windows

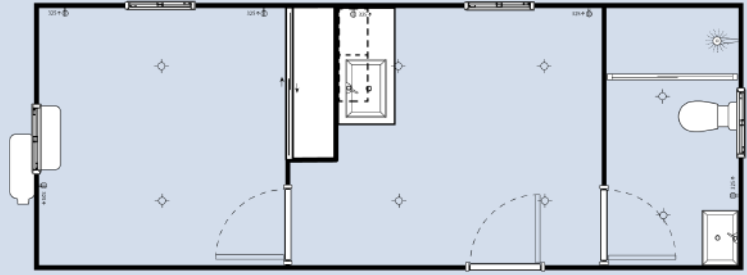

Also available in a “Base” empty unit

Premium Unit

1 1 1 **22m² Internal** 3m (W) x 7.9m (L) x 3.0m (H)

- ✓ Full Kitchen (Incl. Appliances)
- ✓ Premium Bathroom (Tiled Floor and Walls)
- ✓ Australian Standard Plumbing & Electrical
- ✓ 8x LED Down-lights
- ✓ 6x Double Power Points
- ✓ Glass Sliding Door
- ✓ 3x Double Glazed Windows
- ✓ Air-Conditioning

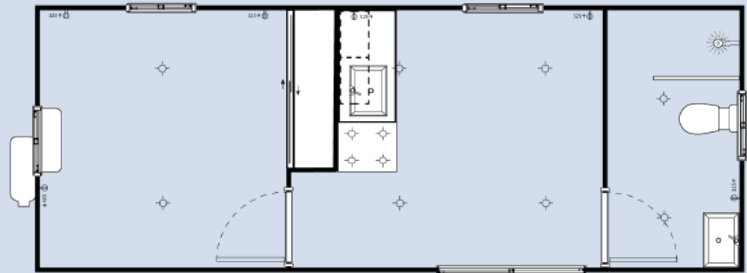

Motel Unit

Studio 1 1 **22m² Internal** 3m (W) x 7.9m (L) x 3.0m (H)

- ✓ Patio Entrance
- ✓ L-Shaped Kitchenette (Excl. Appliances)
- ✓ Classic Bathroom (Tiled Floor and Shower Only)
- ✓ Australian Standard Plumbing & Electrical
- ✓ 8x LED Down-lights
- ✓ 6x Double Power Points
- ✓ Glass Sliding Door
- ✓ 3x Double Glazed Windows

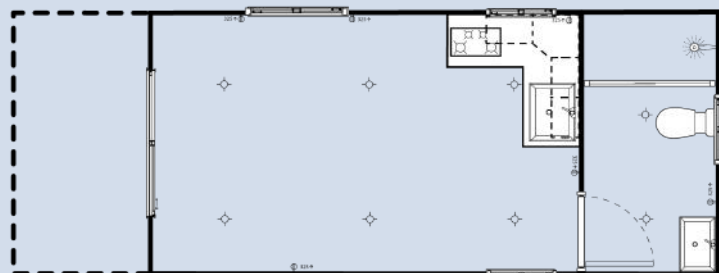

JULIET-2-XL

Two 7.9m x 3m Units - Totaling 47.4m² Externally



Pictured: JULIET2-XL-Classic



Base Unit

45.9m²
Internal

6m (W) x 7.9m (L) x 3.0m (H)

- ✓ Empty Unit Ready For Your Customisations
- ✓ Vinyl Flooring
- ✓ Australian Standard Electrical
- ✓ 2x Double Glazed Windows
- ✓ 12x LED Down-lights
- ✓ 6x Double Power Points
- ✓ Steel Swing Door

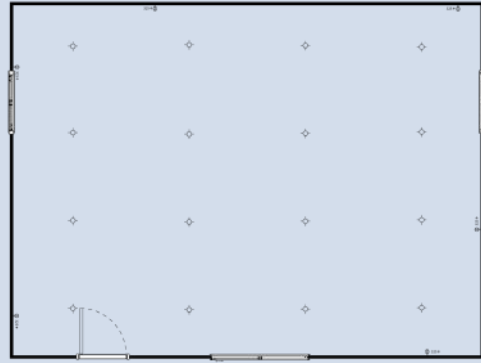

Classic Unit

1 or 2

1

1

45.9m²
Internal

6m (W) x 7.9m (L) x 3.0m (H)

- ✓ 1 or 2 Bedrooms (With built-in wardrobes)
- ✓ Full L-Shape Kitchen (Incl. Appliances)
- ✓ Classic Bathroom (Tiled Floor and Shower Only)
- ✓ Laundry Sink and Room For A Washer (In Bathroom)
- ✓ Australian Standard Plumbing & Electrical
- ✓ 14x LED Down-lights
- ✓ 10x Double Power Points
- ✓ Glass Sliding Door
- ✓ 6x Double Glazed Windows (1 bed)
- ✓ 8x Double Glazed Windows (2 bed)

1 Bed Layout

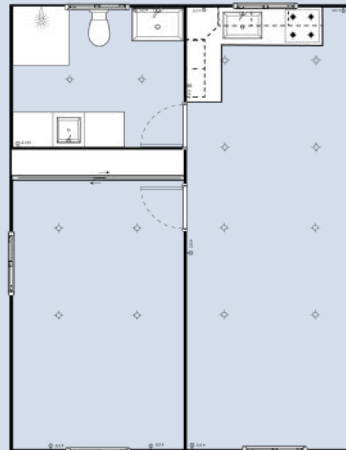

2 Bed Layout

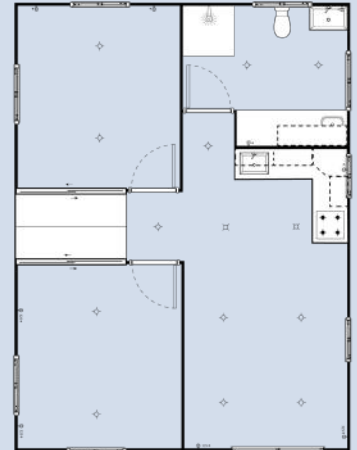

Premium Unit

1 or 2

1

1

45.9m²
Internal

6m (W) x 7.9m (L) x 3.0m (H)

- ✓ 1 or 2 Bedrooms (With built-in wardrobes)
- ✓ Full Kitchen (Incl. Appliances)
- ✓ Premium Bathroom (Tiled Floor and Walls)
- ✓ Laundry Sink and Room For A Washer (In Bathroom)
- ✓ Australian Standard Plumbing & Electrical
- ✓ 14x LED Down-lights
- ✓ 10x Double Power Points
- ✓ Glass Sliding Door
- ✓ 6x Double Glazed Windows (1 bed)
- ✓ 8x Double Glazed Windows (2 bed)

1 Bed Layout

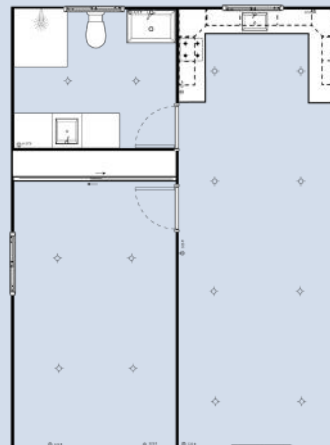

2 Bed Layout

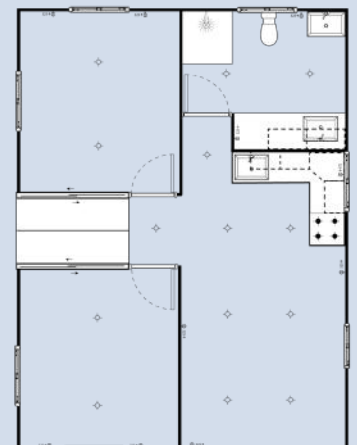

JULIET-3-XL

Three 7.9m x 3m Units - Totaling 71.1m²



Pictured: JULIET3-XL-Premium



Base Unit

68.1m²
Internal

9m (W) x 7.9m (L) x 3.0m (H)

- ✓ Empty Unit Ready For Your Customisations
- ✓ Vinyl Flooring
- ✓ Australian Standard Electrical
- ✓ 5x Double Glazed Windows
- ✓ 24x LED Down-lights
- ✓ 7x Double Power Points
- ✓ Steel Swing Door

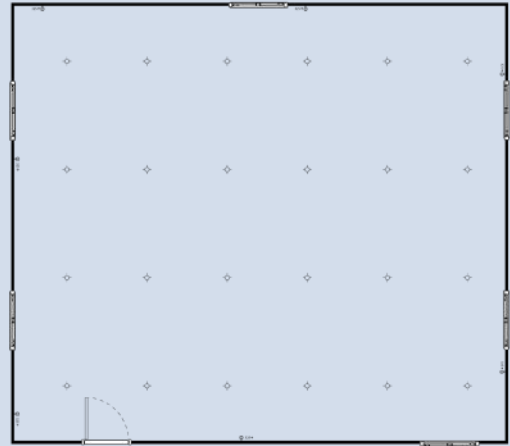

Classic Unit



68.1m²
Internal

9m (W) x 7.9m (L) x 3.0m (H)

- ✓ 2 Bedrooms (With built-in wardrobes)
- ✓ Full L-Shape Kitchen (Incl. Appliances)
- ✓ Classic Bathroom (Tiled Floor and Shower Only)
- ✓ Laundry Sink and Room For A Washer (In Bathroom)
- ✓ Australian Standard Plumbing & Electrical
- ✓ 20x LED Down-lights
- ✓ 12x Double Power Points
- ✓ Glass Sliding Door
- ✓ 6x Double Glazed Windows

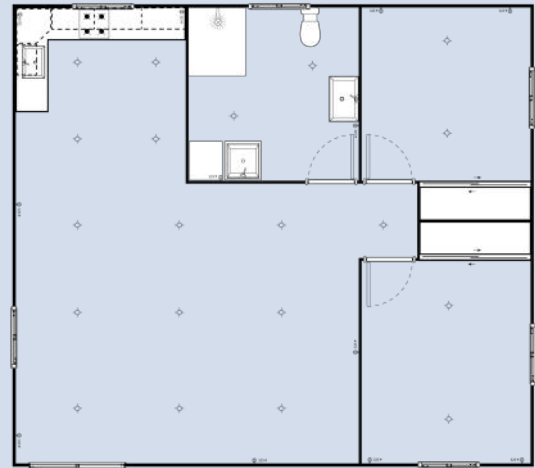

Premium Unit



68.1m²
Internal

9m (W) x 7.9m (L) x 3.0m (H)

- ✓ 2 Bedrooms (With built-in wardrobes)
- ✓ Full U-Shape Kitchen (Incl. Appliances)
- ✓ Premium Bathroom (Tiled Floor and Walls)
- ✓ Laundry Sink and Room For A Washer (In Bathroom)
- ✓ Australian Standard Plumbing & Electrical
- ✓ 20x LED Down-lights
- ✓ 12x Double Power Points
- ✓ Glass Sliding Door
- ✓ 6x Double Glazed Windows

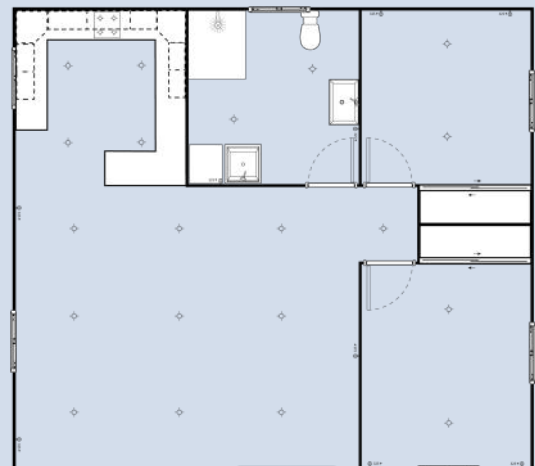

JULIET-4-XL

Four 7.9m x 3m Units - Totaling 94.8m²



Pictured: JULIET4-XL-Premium Plus Veranda



Base Unit

91.8m²
Internal 12m (W) x 7.9m (L) x 3.0m (H)

- ✓ Empty Unit Ready For Your Customisations
- ✓ Vinyl Flooring
- ✓ Australian Standard Electrical
- ✓ 7x Double Glazed Windows
- ✓ 24x LED Down-lights
- ✓ 6x Double Power Points
- ✓ Steel Swing Door



Classic Unit

 3  1  1 **91.8m²**
Internal 12m (W) x 7.9m (L) x 3.0m (H)

- ✓ 3 Bedrooms (With built-in wardrobes)
- ✓ Full L-Shape Kitchen (Incl. Appliances)
- ✓ Classic Bathroom (Tiled Floor and Shower Only)
- ✓ Laundry Sink and Room For A Washer (In Bathroom)
- ✓ Australian Standard Plumbing & Electrical
- ✓ 26x LED Down-lights
- ✓ 15x Double Power Points
- ✓ 13x Double Glazed Windows
- ✓ 2x Glass Sliding Doors
- ✓ Steel Swing Back Door

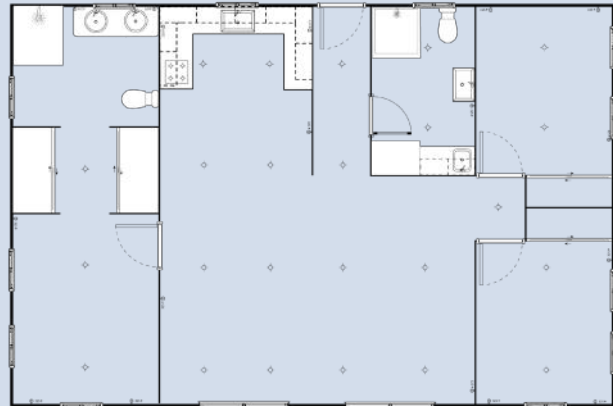

Premium Unit

 3  1  1 **91.8m²**
Internal 12m (W) x 7.9m (L) x 3.0m (H)

- ✓ 3 Bedrooms (With built-in wardrobes)
- ✓ Full U-Shape Kitchen (Incl. Appliances)
- ✓ Premium Bathroom (Tiled Floor and Walls)
- ✓ Laundry Sink and Room For A Washer (In Bathroom)
- ✓ Australian Standard Plumbing & Electrical
- ✓ 26x LED Down-lights
- ✓ 15x Double Power Points
- ✓ 2x Glass Sliding Doors
- ✓ 13x Double Glazed Windows
- ✓ Steel Swing Back Door



JULIET Customisation Guide

Roof & Veranda Options

With multiple roof and veranda options, you can customise your JULIET to suit your style. Choose from slightly sloped, gable, or skillion roof designs, paired with open, railed, mini, or enclosed veranda options. Each roof and veranda is supplied as a complete kit with your JULIET, making on-site installation straightforward.



Pictured: JULIET2-S-Classic Plus Gable Roof & Veranda

We offer three roof styles;



Slightly Sloped



Gable



Skillion

We offer four veranda styles;

Open



Mini



Railing Edges



Sun-room/Enclosed



Choose the design that best suits your space. Our team will help you select roof and flooring materials that complement your JULIET, creating a seamless and stylish finish.

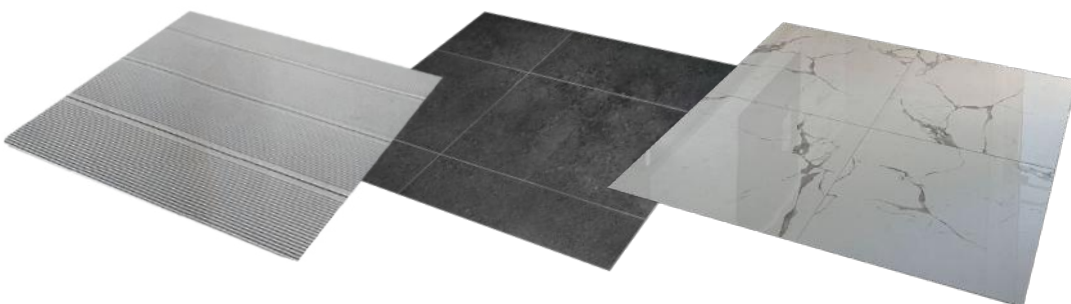

Talk to our team about our custom options!

We offer three door styles;

A range of door options are available to suit different styles and functional needs. Choose from sleek glass sliding doors for a modern look, elegant tri-fold glass and steel frame doors that create a seamless indoor-outdoor connection, or classic swing doors for a timeless and practical solution. Each option is designed to complement your JULIET while maximising natural light, accessibility, and functionality.

Steel Swing Door



Glass Sliding Door



Trifold Glass Door



Plenty Of Floor & Wall Styles

A wide range of flooring and wall finish options are available, including tiles and vinyl, giving you the flexibility to customise throughout your space. Choose different flooring for each room, add full or feature wall tiling in the bathroom, or incorporate a stylish kitchen splash-back.

We offer five tile styles;



Or our classic grey vinyl will complement any aesthetic



Grey Wood Feature Wall

Also available in:



Light Grey

Brown

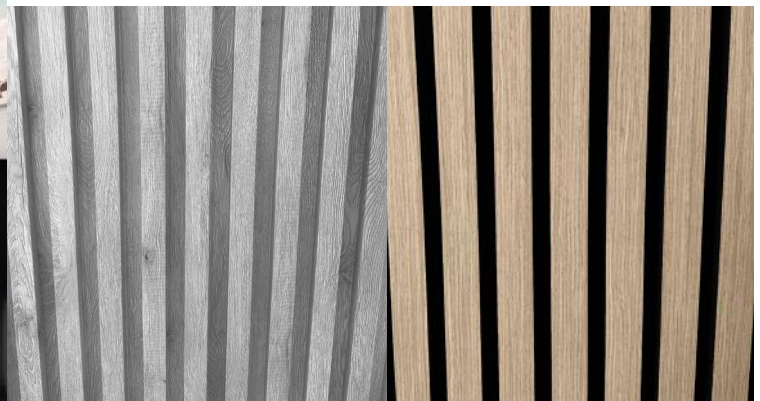

System & Utilities

JULIET Series

Septic Systems

Available in a two capacities, 1500L and 2500L, our tanks are available as holding, absorption or trench tanks and give you the freedom to choose the perfect solution for your residential property or off-grid installation.



Accessibility Options

- Grab rails
- Accessible toilets and shower fittings
- Folding shower seats
- Mixer taps
- Unisex toilet & shower signage



Appliances

- Fridges (bar and full size)
- Front load washing machines
- Heat pump dryers
- Gas and electric ovens
- Range-hoods



Water Storage & Pumps

Reliable water solutions for off-grid living:

- Bushmans tanks up to 20,000L for water harvesting
- High-quality Italian-made Lowara pumps with Genyo electronic controllers



Air Conditioner

We offer a full range of reverse-cycle units from 2.5kW to 9.6kW, providing efficient heating and cooling performance.



Energy Solutions

Solar setups tailored to your energy and off-grid needs.

- Panel systems up to 7kW
- Battery storage systems up to 20kWh



Hot Water Systems

Choose from gas or electric systems tailored to your unit size and demand, including continuous flow units and advanced heat-pump models for maximum efficiency.



Electrical Setup

JULIET Series

Each JULIET unit is pre-wired to Australian Standards with certified components and licensed installation. A single industrial plug enables quick grid connection, and external access points allow easy linking for rapid setup and relocation.

What's Included

- Certified light switches, power outlets, LED down-lights
- Internal switchboard with safety circuit breakers
- Full internal cabling, fitted and tested prior to delivery
- Isolation switches for key appliances
- Industrial-grade exterior plug-in power connection (like a caravan)
- Weatherproof exterior access points for multi-module configurations



Off-Grid Ready

- Optional solar power generation system
- Lithium battery storage
- Solar inverter installation
- Outdoor recessed "Utilities Nook" to house solar, hot water and more



We provide dedicated electrical circuits for high-power appliances, so you can run an electric oven, split-system air conditioning, fridges, and more.

i

Final connection to the grid must be completed by a licensed electrician.

Plumbing & Water Systems

JULIET Series

JULIET units are built for efficient water and waste management on-grid, off-grid, or in between. All plumbing is Australian-installed with certified parts to suit your setup.

Key Features

- All hot and cold water and waste lines pre- installed
- Exterior plumbing outlets for fast connection
- Flexible placement of inlets/ outlets to suit your land and layout
- Waterproofing done by specialists to ensure long-term performance
- Compatible with both council connections and off-grid setups

Bathrooms and kitchens come ready to go fully waterproofed fitted with mixer taps, waste drains and ready for connection.



For faster setup and easier servicing, we place water and waste outlets on exterior walls, however we're happy to customise this for your container home.

Final connection must be completed by a licensed plumber.

i

Your Build & Delivery Process

JULIET Series

1. Choose Your Unit

Begin by choosing the layout and size that best suits your needs, and once you've made your selection, we'll prepare and provide a detailed written quote.

2. Place Your Order

To confirm your order for a JULIET home, a 20% deposit is required. This payment secures your position in our production queue and guarantees that your build timeline is reserved.

3. We Build, You Prep the Site

During the time your JULIET is being constructed to your specifications in our manufacturing facility, you'll need to ensure your site is properly prepared. This typically involves installing level footings, which may include besser blocks, a concrete slab, or another suitable foundation option.

4. Your Unit is Delivered to Site

Once construction is complete, your unit is delivered directly to your site. The JULIET arrives fully built and ready for immediate connection.

5. Crane Into Place

Once onsite, the JULIET is expertly craned into its final position, aligning perfectly with your prepared footings to ensure a stable and secure installation.

6. Join & Seal

If your JULIET includes multiple modules, they are sealed together on-site and fastened using the provided components following the installation guide.

7. Connect Services

The JULIET units require licensed trades to connect power, water and sewage, with guidance provided ahead of time to streamline the process.

8. Move in & Enjoy

Once everything is connected and complete, you're ready to settle in and enjoy your new space!

Consult with your local council about required permits before purchase



About Home Technology Club

Modular Solutions Built for Australian Conditions

Home Technology Club specialises in modular homes and transportable living solutions for residential, commercial, rural, and off-grid applications across Australia.

Backed by over 48 years of industry experience through the Cornick Group, we deliver durable, easy-to-deploy modular homes ranging from compact studio units to customised multi-module configurations. Manufactured in Sydney using quality materials and certified components, our homes are available in on-grid, off-grid, and hybrid setups, with flexible customisation options to suit the needs of each project.

Australian Owned

Proudly family owned and operated in Australia

Made In Sydney

Built locally in our Windsor, New South Wales facility

Built To Last

Designed for long-term use with a durable, practical construction

- Modular Container Homes
- Portable Toilets & Shower Blocks
- Portable Offices & Site Buildings
- Off-Grid Power, Water & Waste Solutions
- Temporary Accommodation Units
- Custom Layouts & Configurations

Custom add-ons and configurations available to suit your site requirements



More Than Modular Homes

Explore Our Portable Bathroom Range



Single Bathroom Layouts

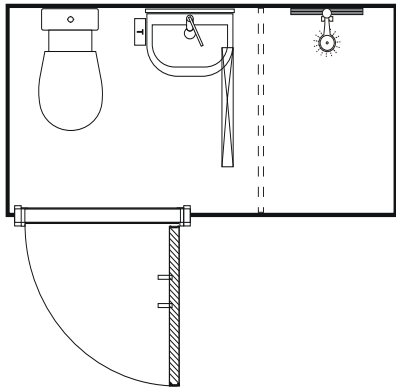

Bathroom Block Layouts

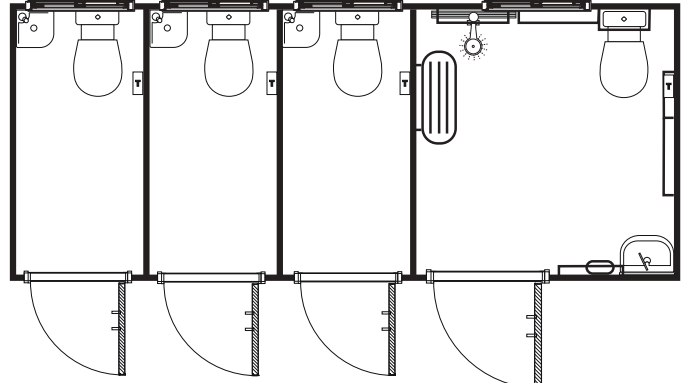

We design and build high-quality portable bathrooms, manufactured in Sydney. From compact standalone units to larger customised layouts, our portable bathroom range delivers practical, durable solutions for residential, commercial, event, and off-grid applications.

**Ask Us About Our
Portable Bathroom Brochure!**



Home Technology Club

Amenities Blocks

Portable Toilets, Showers
& Accessible Bathrooms

For more information, call (02) 4545 2599 or visit online at www.hometechclub.au

Visit Australia's Largest Display Village for Modular Homes & Portable Bathrooms

59 Mulgrave Rd, Windsor NSW 2756, Australia

Contact us:

P: **(02) 4545 2599**

E: **sales@hometechclub.au**

www.hometechclub.au



Walk Through
Our Complete
Range Of ●
Display Units

Home Technology Club (HTC)
is a company of Cornick Pty Ltd.
Copyright 2026, all rights reserved HTC.