



Dynamic®

2026 PROFESSIONAL SERIES



*Culinary inspiration
source since 1964*

www.dynamicmixers.com





REPRESENTED IN MORE THAN
120 COUNTRIES



FRANCE

MORTAGNE-SUR-SÈVRE (85)

Tel. +33 (0)2 51 63 02 72
contact@dynamicmixers.com

518 rue Léo Baekeland
BP57-85290 Mortagne-sur-Sèvre FRANCE

www.dynamicmixers.com



2
PRODUCTION
SITES



NORTH
AMERICA

CANADA

Montreal, Quebec
3227 Boul. pitfield - H4S-1H3
www.dynamicmixers.ca

USA

1 320 ROUTE 9 # 1352
Champlain, NY - 12919
www.dynamicmixersusa.com

USA / CANADA

Tel. : +1-800-267-7794 / +1-514-956-0127

Fax : +1-877-668-6623 / +1-514-956-8983

info@dynamicmixers.com



GERMANY

Eine starke Marke der
Groupe NADIA GMBH

GERMANY

Tel. +49 (0)7851 886 45-0
Fax +49 (0)7851 886 45-32
info@dynamic-professional.de

Robert-Koch Strasse 7
77694 Kehl

www.dynamic-professional.de

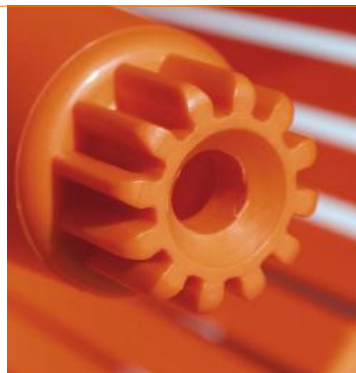

VEGETABLE SLICER / TABLE TOP FOOD PROCESSOR

ACCESSORIES

ELECTRIC COMBINED



ELECTRIC VEGETABLE SLICER



ELECTRIC TABLE TOP FOOD PROCESSOR



BLEND & MIX



Ripple cut



Slicing disc



Julienne disc



Grating disc

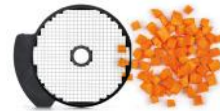

Dicing set



French fries set



Disc support



Standard blade



Serrated blade



Micro-serrated blade

SALAD SPINNERS



MISCELLANEOUS

DYNACUBE



DYNAJUICER



FMA



MINI SERIES

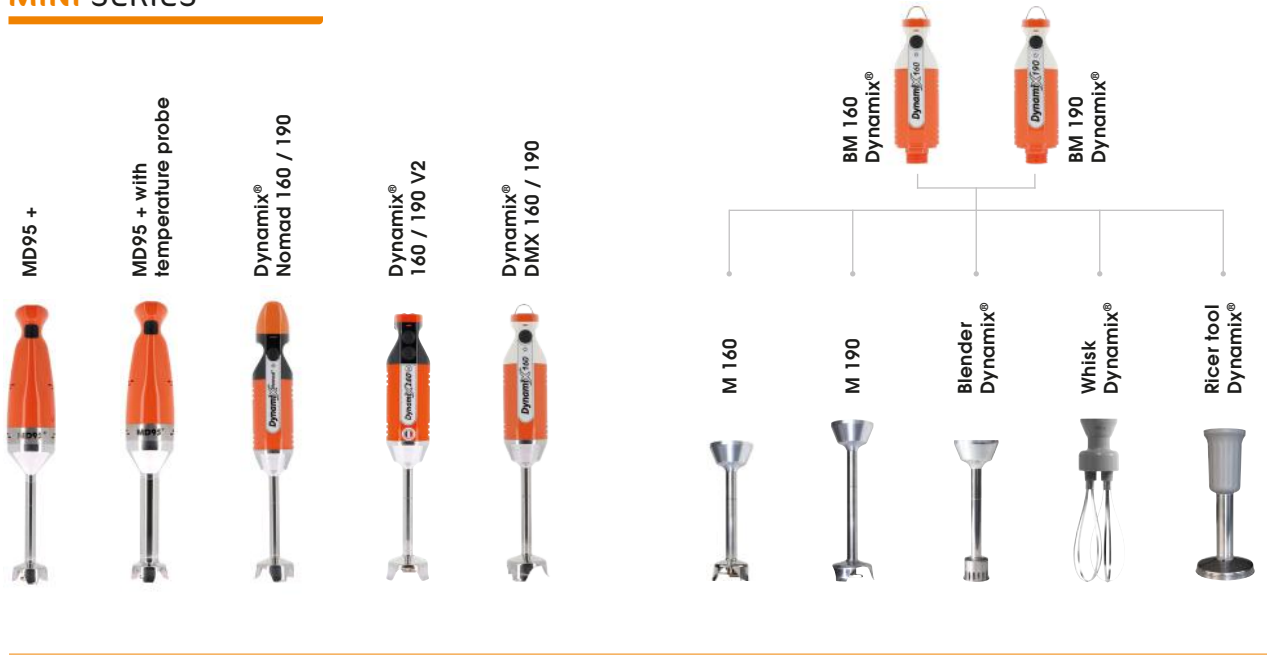

JUNIOR SERIES

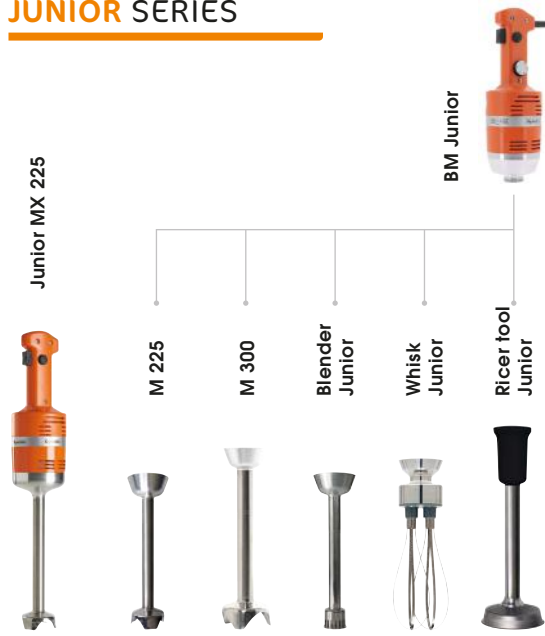

SENIOR SERIES

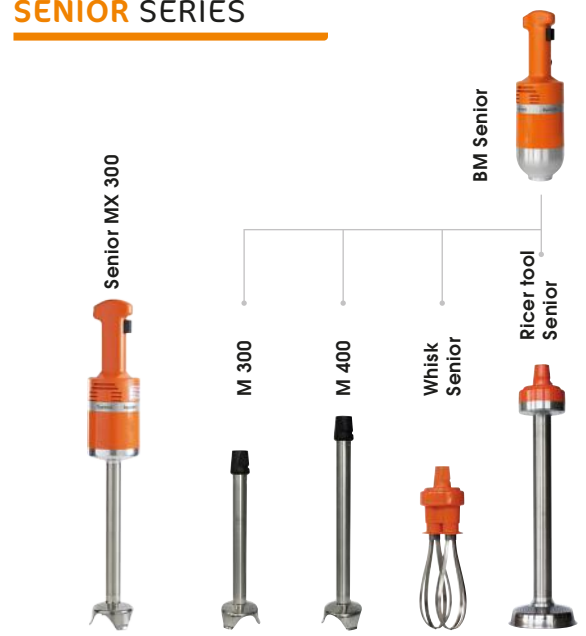

TURBO LIQUIDIZER



2026 SERIES



MASTER SERIES

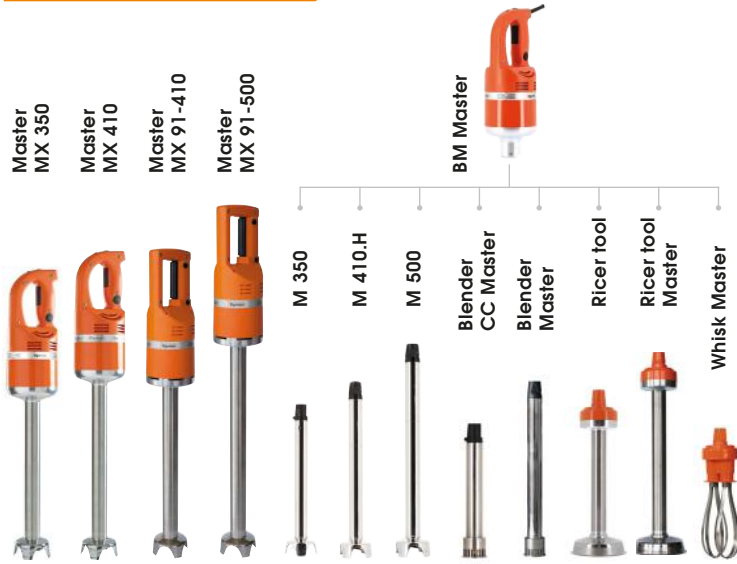

SMX SERIES



BRATT PAN SERIES

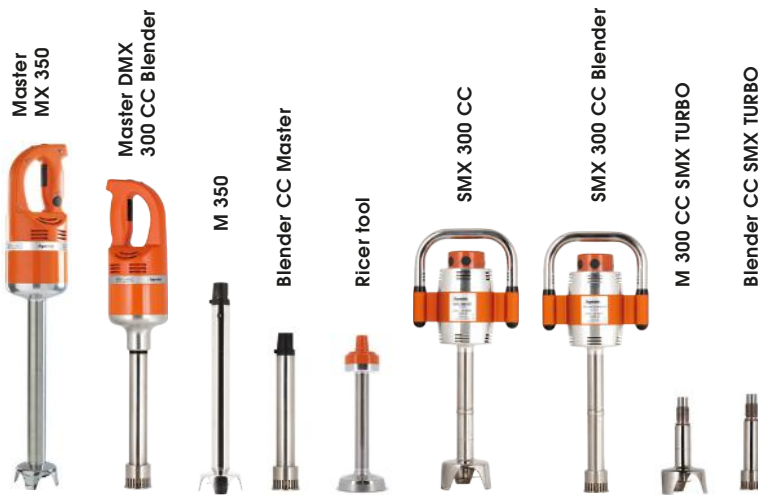

RICER TOOL



EASYMIX

FOR MASTER OR SMX SERIES





2026 PROFESSIONAL SERIES



*Serving you
since 1964*



TABLE OF CONTENTS

PROFESSIONAL CATALOGUE 2026

Global network	p. 2
Dynamic® 2026 Series	p. 3
Commitments	p. 8
Our ranges for your professions	p. 10
MD95+	p. 12
Dynamix®	p. 14
Dynamix® V2	p. 15
Dynamix® NOMAD	p. 16
Accessories & Packs Dynamix®	p. 18
Junior	p. 20
Accessories & Packs Junior	p. 22
Senior	p. 24
Accessories & Packs Senior	p. 26
Master	p. 28
Accessories & Packs Master	p. 32
SMX	p. 34
Accessories & Supports SMX	p. 37
Bratt Pan	p. 38
Easymix	p. 40
Ricer tool	p. 44
Turbo liquidizer	p. 46
Turbo liquidizer accessories	p. 50
Electric Combined	p. 52
Electric Vegetable Slicers	p. 54
Electric Table top food processor	p. 56
Blend & Mix	p. 58
Discs & Packs	p. 60
Manual vegetable slicer	p. 62
Salad spinners	p. 64
Various	p. 66
Sales supports marketing	p. 67
News, online store & Customer Service	p. 68
General sales conditions	p. 69



ENGINEERED FOR PROFESSIONALS

Each of our devices is designed to provide you with the professional performance essential to fulfilling your passion.



DESIGNED TO BE REPAIRED

Our products are designed to be easily repairable, disassembled, and reassembled. DYNAMIC is committed to ensuring that its products are repairable for 10 years in France and worldwide, and guarantees the immediate availability of spare parts.

A rigorous renewal and stock monitoring process ensures quick supply to every customer around the world.



WARRANTED PRODUCTS

Each DYNAMIC product comes with an instruction and warranty manual.

In this document, you will find all our guidance for starting, using, and maintaining your appliance to ensure their long-lasting usage.



1 / CARBON FOOTPRINT MONITORING & COMMITMENTS

Since 2021, Dynamic has carried out an annual carbon footprint assessment to measure its environmental impact, track progress, and adjust its reduction strategy.

In 2024, our emissions reached **372 tCO₂ per million euros of turnover**, a level below the industrial sector average (500 to 3,000 tCO₂e/M€ - source: Statista).

Our objective remains unchanged: to reduce our emissions by 4.2% per year (Scopes 1 and 2) and 2.5% for Scope 3 by 2030, in line with the Paris Agreement targets.

Progress monitoring:

- Gradual reduction of emissions linked to purchasing and manufacturing
- Logistics optimization and circular economy initiatives

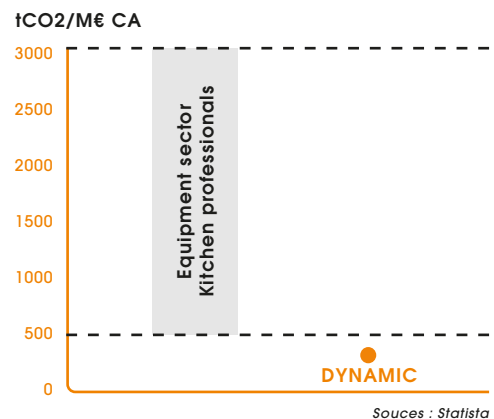

ECO-DESIGN & CIRCULARITY

2 / A STRENGTHENED ECO-DESIGN APPROACH

At Dynamic, the design of **robust, durable, and repairable** products has been part of our DNA since 1964.

This commitment drives every innovation. In response to current environmental challenges, we are reinforcing this approach by integrating **eco-design** principles into each stage of the product life cycle.

Our strategy is built around four key pillars:

1. **Packaging reduction:** use of recycled cardboard, gradual elimination of single-use plastics.
2. **Logistics optimization:** fewer transports through more efficient industrial organization.
3. **Skills development:** staff training in eco-design principles and practical application.
4. **Impact measurement:** 88% of our products are now covered by a Life Cycle Assessment (LCA) to identify improvement areas right from the design stage.

This strategy aims to **limit environmental impact without compromising performance**, embracing a circular approach: design better to consume less, repair rather than replace, and increase the use of recyclable materials.

SOCIAL COMMITMENT

3 / INCLUSION, INTEGRATION AND TRAINING

At Dynamic, social responsibility is an integral part of our values. It translates into concrete actions promoting inclusion and skills development.

Protected work & integration:

- Dynamic promotes the inclusion of people with disabilities through strong partnerships with local adapted companies.

Training:

- In 2024, 58% of employees received an average of 3 days of training.

Towards a more inclusive company:

- Ongoing partnerships with integration and disability organizations.
- Future initiatives: improved accessibility, team awareness on diversity, and continuous training efforts.

Key HR figures (2024):

- Employees with disabilities: 2.84%
- Subcontracting (labour cost): €17,733.66
- Training hours delivered: 625 hours
- Trained employees: 30
- Average hours per trained employee: 20.83
- Average hours per total workforce: 11.42

Because every field has its own needs.



CATERING COMMERCIAL

FAST-FOOD

Fast food
Fast-food
Juice bars
Takeaway
Salad bars and sandwich shops
Self-service cafeterias
Food courts

TABLE SERVICE

Breweries
Traditional restaurants
Themed restaurants
Chain restaurants
Bistronomic restaurants
Gourmet restaurants

HOTEL CATERING

Hotels of all categories
Banqueting
Holiday centres
Campsites
Staff restaurants



CATERING COLLECTIVE

SCHOOL CATERING

Nurseries
Nursery and primary schools
Secondary schools - Sixth form colleges
Universities
Central kitchens

CORPORATE CATERING

Company restaurants
Administrative restaurants
Life bases
Armed forces
Prisons
Central kitchens

HEALTHY CATERING

Retirement homes - Nursing homes
Hospitals-Clinics
Specialised care centres
Central kitchens



BAKERS & PASTRY CHEFS

PROFESSIONS

Bakers
Pastry chefs
Tea rooms
Confectioners



CHOCOLATE MAKERS & ICE CREAM MAKERS

PROFESSIONS

Artisanal chocolate shops
Pastry chefs and chocolatiers
Artisanal ice cream parlours
Tea rooms
Production workshops
Training schools



BUTCHERS & CATERERS

PROFESSIONS

Butchers and delicatessens
Fishmongers
Caterers and event organisers

MD95 +

PROFESSIONAL SERIES

A small and robust appliance.

MONOBLOCK EQUIPMENT | 250 W | 1 TO 8 L

+ ADVANTAGES

+ ROBUSTNESS

Stainless steel monobloc designed for intensive daily use. Additional vents for improved motor ventilation and increased service life.

+ ERGONOMY

Comfortable handle, intuitive grip, and perfect balance for easy handling

+ VERSATILITY

One-click speed control
LED display for increased precision
4 or 2 blade knife for versatile production (ganache, icing, gravy, etc.)

+ MODEL WITH TEMPERATURE PROBE

Built-in probe with digital display showing real-time temperature (5°C to 115°C).



SIRH+
INNOVATION
AWARDS 2025



**VARIABLE
SPEED**
OPTIONAL



**VARIABLE
SPEED**



**PATENTED
SYSTEM**



**TEMPERATURE
PROBE**

160 mm



1 - 8 L

NEW

MD95 +

Knife	2 blades / 4 blades
Output	250 W
Total length	420 mm
Shaft length	160 mm
Bell diameter	55 mm
Weight / Packaged	1,3 kg / 1,5 kg
Speed R.P.M	11 500 / 3 000 to 11 500
Item code	MX180 / MX183 (fixed speed) MX181 / MX184 (variable speed)

160 mm



1 - 8 L

NEW

MD95 + WITH TEMPERATURE PROBE

Knife	2 blades / 4 blades
Output	250 W
Total length	420 mm
Shaft length	160 mm
Bell diameter	55 mm
Weight / Packaged	1,4 kg / 1,7 kg
Speed R.P.M	3 000 to 11 500
Item code	MX182 / MX185

DYNAMIX®

PROFESSIONAL SERIES

Specially designed for small preparations, sauces, and emulsions.

DETACHABLE EQUIPMENT | 220 / 250 W | 1 TO 8 L

+ ADVANTAGES

+ PERFORMANCE

Special tools for a smooth mix.

+ ROBUSTNESS

Stainless steel foot.

+ USABILITY

Quickly accessible speed control.

+ HYGIENE

Detachable mixer tool, tube and bell
100% in stainless steel for easy cleaning.

+ COMFORT

Lightness for easy use.

+ VERSATILITY

Various accessories, whisk, Dynacutter bowl,
Ricer tool, Blender accessory.



160 mm



1 - 4 L



1 - 8 L

SUPPORT DYNAMIX® / ORANGE OR BLACK

Item code

SM030 / SM030N



DYNAMIX®

	DMX 160	DMX 190
Knife	2 blades	4 blades
Output	220 W	250 W
Total length	395 mm	425 mm
Shaft length	160 mm	190 mm
Bell diameter	66 mm	66 mm
Weight/ Packaged	1 kg / 1,2 kg	1 kg / 1,5 kg
Speed R.P.M.	3 000 to 13 000	3 000 to 13 000
Item code	MX050	MX090



DYNAMIX® V2

PROFESSIONAL SERIES

Two speeds for ultra-fast adjustment.

DETACHABLE EQUIPMENT | 220 / 250 W | 1 TO 8 L

+ ADVANTAGES

+ PERFORMANCE

2 speeds (8 000 rpm and 13 000 rpm).

+ ROBUSTNESS

Stainless steel foot.

+ HYGIENE

Detachable mixer tool, tube and bell 100% in stainless steel for easy cleaning.

+ COMFORT

Lightness for easy use.

+ VERSATILITY

Various accessories, whisk, Dynacutter bowl, ricer tool, Blender accessory.

AVAILABLE IN 3 COLORS

Orange color in standard

DYNAMIX® 160 V2

Orange / Black

Item code



MX055

Red / Black

Item code



MX056

White / Black

Item code



MX057

DYNAMIX® 190 V2

Orange / Black

Item code



MX095

Red / Black

Item code



MX096

White / Black

Item code



MX097



160 mm

160



1 - 4 L

190



1 - 8 L

DYNAMIX® V2

	DMX 160 V2	DMX 190 V2
Knife	2 blades	4 blades
Output	220 W	250 W
Total length	395 mm	425 mm
Shaft length	160 mm	190 mm
Bell diameter	66 mm	66 mm
Weight/ Packaged	1 kg / 1,2 kg	1,2 kg / 1,5 kg
Speed 1 R.P.M.	8 000	8 000
Speed 2 R.P.M.	13 000	13 000
Item code	According to colors	According to colors



NOMAD

PROFESSIONAL SERIES

Wireless, the freedom of movement in the kitchen.

DETACHABLE EQUIPMENT | 2000 MAH 12 VDC | 1 TO 8 L



ADVANTAGES

+ PERFORMANCE

Special tools for a smooth mix.

+ ROBUSTNESS

Stainless steel foot.

+ HYGIENE

Detachable mixer tool, tube and bell 100% in stainless steel for easy cleaning.

COMPLIANT WITH STANDARDS 



CHARGER

Item code **AC590**



Delivered with a charger lithium-ion battery.
(Charging time 45 minutes)

BATTERY

Item code **AC585**



Compact size and low battery weight
for effortless work.
Quick and easy replacement.

* Others accessories (except blender) available separately.



DYNAMIX® NOMAD

	160	190
Knife	2 blades	2 blades
Output	2 000 mAh 12Vdc	2 000 mAh 12Vdc
Total length	450 mm	480 mm
Shaft length	160 mm	190 mm
Bell diameter	66 mm	66 mm
Weight / Packaged	1,1 kg / 1,9 kg	1,5 kg / 2,2 kg
Speed R.P.M	10 000	10 000
Item code	MX130	MX140

DYNAMIX®

DETACHABLE EQUIPMENT | 220 / 250 W | 1 TO 8 L



ACCESSORIES

ACCESSORIES AVAILABLE SEPARATELY

Item code	Description	Output	Speed R.P.M.	Capacity	Knife
1	AC515 BM 160 DYNAMIX	220 W	3 000 / 13 000		
2	AC514 BM 190 DYNAMIX	250 W	3 000 / 13 000		
3	AC560 BLENDER DYNAMIX		3 000 / 13 000	1 to 4 L	hammer star-shaped
4	AC521 M 160		3 000 / 13 000	1 to 4 L	2 blades
5	AC550 M 190		3 000 / 13 000	1 to 8 L	4 blades
6	AC540 BLADE PACK				
7	AC516 WHISK DYNAMIX		600 / 2 500	1 to 4 L	
8	AC517 RICER TOOL		70 / 300	1 to 5 Kg	
9	AC510 GRADUATED BOWL			1 L	
10	AC513 STAINLESS STEEL JUG			3 L	
11	AC518 CUTTER BOWL		600 / 2 500	0,8 L	



EXTRACTABLE WHISKS



185 mm

7

EXCLUSIVE PRODUCT



126 mm

8



9



Suitable induction

10



11

PACKS

ACCESSORIES AVAILABLE SEPARATELY

DYNAMIX® COMBI 160

Item code	MF052
-----------	-------

DYNAMIX® TRIO 160

Item code	MF050
-----------	-------

1 + 4 + 7

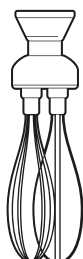
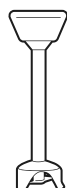
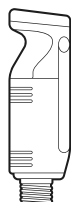

1 + 4 + 7 + 8

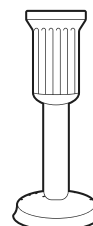
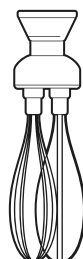
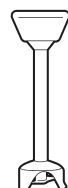
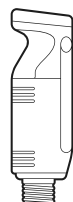

JUNIOR

PROFESSIONAL SERIES

The lightest on the market in its category.

MONOBLOCK EQUIPMENT | 270 W | 1 TO 25 L

+ ADVANTAGES

+ PERFORMANCE

Special tools for a smooth mix.

+ ROBUSTNESS

Stainless steel foot.

+ USABILITY

Variable speed easily switchable.

+ HYGIENE

Detachable mixer tool, tube and bell 100% in stainless steel for easy cleaning.

+ COMFORT

Lightness for easy use.

+ VERSATILITY

Various accessories, whisk, Dynacutter bowl, Ricer tool, Blender accessory.

+ SAFETY

Unlocking safety feature.





VARIABLE
 SPEED
 OPTIONAL

225 mm

225

 1 - 25 L

225

 1 - 25 L



VARIABLE
 SPEED

185 mm

 1 - 5 L

JUNIOR MX

225

225

Knife	2 blades	4 blades
Output	270 W	270 W
Total length	505 mm	580 mm
Shaft length	225 mm	225 mm
Weight / Packaged	1,7 kg / 2 kg	1,7 kg / 2 kg
Speed R.P.M	12 000	12 000
Item code	MX020 / MX020.V	MX025 / MX025.V

JUNIOR WHISK

Output	270 W
Total length	500 mm
Shaft length	185 mm
Weight / Packaged	1,4 kg / 1,7 kg
Speed R.P.M	300 to 2 000
Item code	FT005

JUNIOR

DETACHABLE EQUIPMENT | 270 W | 1 TO 25 L



ACCESSORIES

ACCESSORIES AVAILABLE SEPARATELY

Item code	Description	Output	Speed R.P.M.	Capacity	Knife
1	AC100 BM JUNIOR	270 W	3 000 / 12 000		
2	AC101 M 225		3 000 / 12 000	5 to 25 L	2 blades
3	AC105 M 300		3 000 / 12 000	5 to 25 L	4 blades
4	AC066 BLENDER JUNIOR		3 000 / 12 000	1 to 10 L	hammer star-shaped
5	AC102 WHISK JUNIOR		600 / 2 500	1 to 5 L	
6	AC103 RICER TOOL JUNIOR		70 / 300	1 to 10 Kg	
7	AC104 CUTTER BOWL JUNIOR		600 / 2 500	0,8 L	

EXTRACTABLE WHISKS



185 mm

5

EXCLUSIVE PRODUCT



200 mm

6



7

PACKS

ACCESSORIES AVAILABLE SEPARATELY

JUNIOR COMBI 225

Item code **MX022**

JUNIOR DMX 225

Item code **MX021.V**

JUNIOR DMX 300

Item code **MX024**

JUNIOR DMX 225 BLENDER

Item code **MX110**

1 + 2 + 5

1 + 2

1 + 3

1 + 4

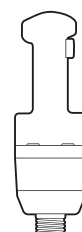
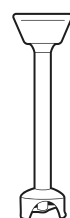
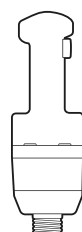
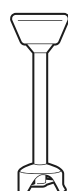
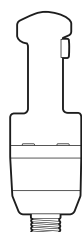
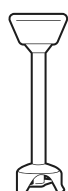
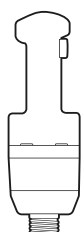

SENIOR

PROFESSIONAL SERIES

An ideal solution for traditional and collective catering.

MONOBLOCK EQUIPMENT | 350 W | 20 TO 40 L

+ ADVANTAGES

+ PERFORMANCE

Special tools for a smooth mix.

+ ROBUSTNESS

Stainless steel foot.

+ USABILITY

Variable speed easily switchable.

+ HYGIENE

Detachable accessories for easy cleaning.

+ COMFORT

Lightness for easy use.

+ VERSATILITY

Various accessories, whisk, Dynacutter bowl, ricer tool.

+ SAFETY

Unlocking safety feature.

COMPLIANT WITH STANDARDS 





**VARIABLE
SPEED
OPTIONAL**



300 mm



20 - 40 L

SENIOR MX 300

Knife	3 blades
Output	350 W
Total length	600 mm
Shaft length	300 mm
Weight / Packaged	2,4 kg / 2,9 kg
Speed R.P.M	9 500
Item code	MX007 / MX007.V

SENIOR

DETACHABLE EQUIPMENT | 350 W | 20 TO 40 L



ACCESSORIES

ACCESSORIES AVAILABLE SEPARATELY

Item code	Description	Output	Speed R.P.M.	Capacity	Knife
1 AC005	BM SENIOR	350 W	2 800 / 9 500		
2 AC006	M 300		2 800 / 9 500	20 to 40 L	3 blades
3 AC016	M 400		2 800 / 9 500	20 to 40 L	3 blades
4 AC007	WHISK SENIOR		300 / 900	5 to 20 L	
5 AC004	RICER TOOL SENIOR		100 / 600	10 to 15 Kg	
6 AC055	STAINLESS STEEL CUTTER BOWL SENIOR		400 / 1 500	5 L	

**EXCLUSIVE
PRODUCT**

**EXTRACTABLE
WHISKS**



4



5



6

PACKS

ACCESSORIES AVAILABLE SEPARATELY

SENIOR COMBI 300

Item code

MF003

SENIOR DMX 300

Item code

MX006

1 + 2 + 4

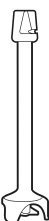
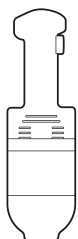

1 + 2

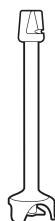

MASTER

PROFESSIONAL SERIES



MONOBLOCK EQUIPMENT | 600 W | 5 TO 100 L

+ ADVANTAGES

+ PERFORMANCE

Special tools for a smooth mix.

+ ROBUSTNESS

Stainless steel foot.

+ USABILITY

Variable speed easily switchable.rapidement.

+ HYGIENE

Detachable foot and bell without tools, tube and bell 100% in stainless steel for easy cleaning.

+ COMFORT

Lightness for easy use.

+ SAFETY

Unlocking safety feature.

COMPLIANT WITH STANDARDS 



VARIABLE SPEED

EXTRACTABLE WHISKS



245 mm



5 - 20 L

WHISK MASTER

Output	600 W
Total length	650 mm
Shaft length	245 mm
Weight / Packaged	3,3 kg / 3,7 kg
Speed R.P.M	300 to 900
Item code	FT001



MASTER MX	91-410	91-500
Knife	3 blades	3 blades
Output	600 W	600 W
Total length	715 mm	800 mm
Shaft length	410 mm	500 mm
Weight / Packaged	3,4 kg / 3,8 kg	3,6 kg / 4 kg
Speed R.P.M	10 500	10 500
Item code	MX005 / MX005.V	MX045 / MX045.V

MASTER MX	350	410
Knife	3 blades	3 blades
Output	600 W	600 W
Total length	700 mm	720 mm
Shaft length	350 mm	410 mm
Weight / Packaged	3,4 kg / 4,1 kg	3,6 kg / 4,1 kg
Speed R.P.M	10 500	10 500
Item code	MX350 / MX350.V	MX004 / MX004.V

MASTER

PROFESSIONAL SERIES

Enhanced versatility!

Use up to 12 attachments with only 1 motor block.

DETACHABLE EQUIPMENT | 600 W | 5 TO 100 L

+ ADVANTAGES

+ PERFORMANCE

Special tools for a smooth mix.

+ ROBUSTNESS

Stainless steel foot.

+ USABILITY

Variable speed easily switchable.

+ HYGIENE

Detachable foot and bell without tools, tube and bell 100% in stainless steel for easy cleaning.

+ COMFORT

Lightness for easy use.

+ VERSATILITY

Various accessories, whisk, Dynacutter bowl, ricer tool, blender foot.

+ SAFETY

Unlocking safety feature.

COMPLIANT
WITH STANDARDS 





40 - 100 L



40 - 100 L



5 - 40 L



40 - 100 L

MASTER DMX

	350	410.H	410 BLENDER	500
Knife	3 blades	3 blades / 4 blades	hammer star-shaped	3 blades
Output	600 W	600 W	600 W	600 W
Total length	700 mm	720 mm	720 mm	810 mm
Shaft length	350 mm	410 mm	410 mm	500 mm
Weight / Packaged	4,5 / 5,2 kg	4,7 / 5,3 kg	5,2 / 6 kg	4 / 4,8 kg
Speed R.P.M	3 000 / 10 500	3 000 / 10 500	3 000 / 10 500	3 000 / 10 500
Item code	MX350.H	MX003.H / MX046.H	MX120	MX012

MASTER

DETACHABLE EQUIPMENT | 600 W | 5 TO 100 L



VARIABLE
SPEED



ACCESSORIES

ACCESSORIES AVAILABLE SEPARATELY

Item code	Description	Output	Speed R.P.M.	Capacity	Knife
1 AC001	BM MASTER	600 W	3 000 / 10 500		
2 AC350.H	M 350		3 000 / 10 500	20 to 100 L	3 blades
3 AC002.H	M 410.H		3 000 / 10 500	20 to 100 L	3 blades
4 AC500	M 500		3 000 / 10 500	20 to 100 L	3 blades
5 AC265	BLENDER CC MASTER		3 000 / 10 500	5 to 40 L	hammer star-shaped
6 AC070	BLENDER MASTER		3 000 / 10 500	5 to 40 L	hammer star-shaped
7 AC008	RICER TOOL		100 / 600	10 to 30 Kg	
8 AC004	RICER TOOL MASTER		100 / 600	10 to 30 Kg	
9 AC003	WHISK MASTER		300 / 900	5 to 20 L	
10 AC202	FM 420		100 / 600	20 to 200 L	
11 AC200	FM 600		100 / 600	20 to 200 L	
12 AC201	FM 700		100 / 600	20 to 200 L	
13 AC055	CUTTER BOWL		400 / 1 500	5 L	

EXTRACTABLE WHISKS



9



10



11

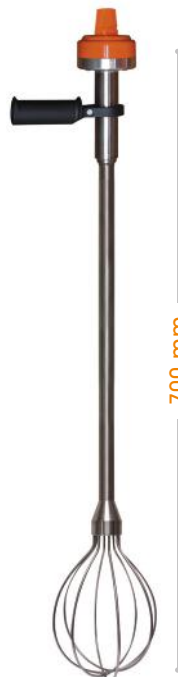

12



A selection of knives (standard or serrated)



13

HOLDING HOOK
(For the Master and SMX ranges, included in the dismantable versions)
Say stop to musculoskeletal disorders with this hook allowing enhanced manoeuvrability of your large mixers. This hook support is placed directly on the rim of the pot.

PACKS

ACCESSORIES AVAILABLE SEPARATELY

MASTER COMBI 410.H

Item code

MF002.H

MASTER TRIO 410.H

Item code

MF001.H

1 + 3 + 9

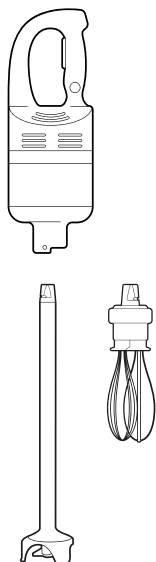

1 + 3 + 8 + 9

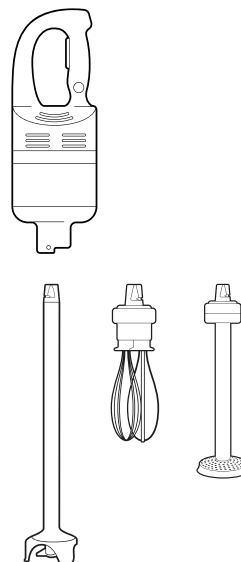

SMX

PROFESSIONAL SERIES

Heavy-duty, designed for communities.

MONOBLOCK EQUIPMENT | 850 W | 75 TO 300 L

+ ADVANTAGES

+ PERFORMANCE

Special tools for a smooth mix.

+ ROBUSTNESS

Stainless steel foot.

+ HYGIENE

Completely removable foot and bell without tools.
Tube and bell 100% stainless steel for easy cleaning.

+ COMFORT

Easy use thanks to its support.

+ SAFETY

Unlocking safety feature.

COMPLIANT
WITH STANDARDS





75 - 300 L

SMX	250ES	350ES	450ES	550ES	600 TURBO
Knife	3 blades	3 blades	3 blades	3 blades	3 blades
Output	850 W	850 W	850 W	850 W	850 W
Total length	575 mm	626 mm	676 mm	728 mm	800 mm
Shaft length	305 mm	356 mm	406 mm	458 mm	530 mm
Weight / Packaged	5,3 kg / 6,8 kg	5,5 kg / 7 kg	5,7 kg / 7,2 kg	5,9 kg / 7,4 kg	6,1 kg / 7,7 kg
Speed R.P.M	11 000	11 000	11 000	11 000	11 000
Item code	MX041ES	MX042ES	MX043ES	MX044ES	MX002T

SMX

PROFESSIONAL SERIES

DETACHABLE EQUIPMENT | 925 / 1 000 W | 75 TO 300 L



75 - 300 L

SMX 700 TURBO



75 - 300 L

SMX 800 TURBO



40 - 100 L

SMX BLENDER TURBO

Knife	3 blades	3 blades	Hammer Star-shaped
Output	925 W	1 000 W	1 000 W
Total length	870 mm	960 mm	860 mm
Shaft length	600 mm	680 mm	580 mm
Weight / Packaged	6,5 kg / 8 kg	6,7 kg / 8,2 kg	6,7 kg / 8,2 kg
Speed R.P.M	11 000	11 000	11 000
Item code	MX040T	MX001T	MX125T

SUPPORTS

FOR YOUR SAFETY AND YOUR COMFORT

Item code	Description	Weight	Diameter
SM001	SM 4	1,9 Kg	400 mm
SM002	SM 6	2,3 Kg	600 mm
SM003	SM 8	2,6 Kg	800 mm
SM004	SM 10	2,8 Kg	1 000 mm
SM005	SM 12	3,2 Kg	1 200 mm
SM006	SA	0,7 Kg	Width of the pot rim 55 mm*

* Maximum diameter of the pot



COMPLIANT WITH STANDARDS



HOLDING HOOK

(For the Master and SMX ranges, included in the dismantable versions)
Say stop to musculoskeletal disorders with this hook allowing enhanced manoeuvrability of your large mixers. This hook support is placed directly on the rim of the pot.



1



170 mm

2



450 mm

3



520 mm

4



170 mm

5



425 mm

6

ACCESSORIES

ACCESSORIES AVAILABLE SEPARATELY

Item code	Description	Output	Speed R.P.M.	Capacity	Knife
1 AC052T	BM SMX TURBO	1 000 W	11 000		
2 AC250T	M 300 CC SMX TURBO		11 000	20 to 100 L	3 blades
3 AC075T	ATTACHMENT 700 TURBO		11 000	75 to 300 L	3 blades
4 AC076T	ATTACHMENT 800 TURBO		11 000	75 to 300 L	3 blades
5 AC255T	BLENDER CC SMX TURBO		11 000	5 to 40 L	Hammer Star-shaped
6 AC072T	BLENDER SMX TURBO		11 000	40 to 100 L	Hammer Star-shaped

BRATT PAN

PROFESSIONAL SERIES

Specifically designed for low-profile, high-capacity containers.

DETACHABLE EQUIPMENT | 600 / 1 000 W | 5 TO 300 L

+ ADVANTAGES

+ PERFORMANCE

Special tools for a smooth mix.

+ ROBUSTNESS

Stainless steel foot.

+ USABILITY

Quick-access speed control. Prevent MSDs with our line, perfect for communal settings and heavy use.

+ HYGIENE

Completely removable foot and bell without tools. Tube and bell 100% stainless steel for easy cleaning.

+ COMFORT

Easy use thanks to its support.

+ SAFETY

Unlocking safety feature.

Dynamic
SMX 300 CC BLENDER
16/ 00001
230V ~ 50/60Hz
1000 W
Poids: 5.8 Kg
Fabriqué en France



MASTER SERIES



MASTER	M350	BLENDER CC	RICER TOOL PP	DMX350	BLENDER CC
Knife	3 blades	Hammer Star-shaped		3 blades	Hammer Star-shaped
Output				600 W	600 W
Total length	350 mm	300 mm	320 mm	700 mm	628 mm
Shaft length				350 mm	300 mm
Weight / Packaged				4,5 kg / 5,2 kg	4 kg / 4,5 kg
Appliance diameter				122 mm	122 mm
Speed R.P.M	3 000 / 10 500	3 000 / 10 500	100 / 600	3 000 / 10 500	3 000 / 10 500
Item code	AC350.H	AC265	AC008	MX350.H	MX165

SMX SERIES

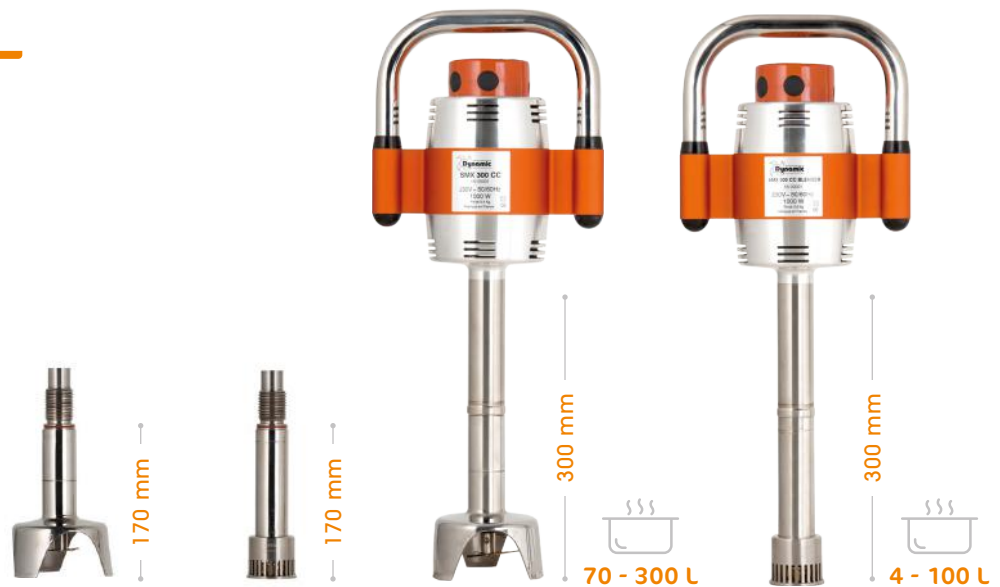

SMX	M300 CC TURBO	BLENDER CC TURBO	300 CC	300 CC BLENDER
Knife	3 blades	Hammer Star-shaped	3 blades	Hammer Star-shaped
Output			1 000 W	1 000 W
Total length	170 mm	170 mm	609 mm	609 mm
Shaft length			300 mm	300 mm
Weight / Packaged			5,9 kg / 7,4 kg	6,1 kg / 7,6 kg
Appliance diameter			236 mm	300 mm
Speed R.P.M	11 000	11 000	11 000	11 000
Item code	AC250T	AC255T	MX150T	MX155T

EASYMIX

PROFESSIONAL SERIES

Effortless mixing, ultimate comfort!

DETACHABLE EQUIPMENT | 600 W | 5 TO 200 L

+ ADVANTAGES

+ VERSATILITY

Available in wall-mounted, mobile, or fixed versions.

+ COMFORT AND ERGONOMICS

Reduces musculoskeletal disorders thanks to an assistance arm.

+ HYGIENE

Designed with certified food-grade materials.

+ SAFETY

Includes an emergency and automatic stop.



WALL



FIXED



TO BE FIXED

ROLLING



Item code	Description	Output	Speed R.P.M.	Capacity	Serie
EMM003H	EASY MIX MASTER DMX 410.H WALL 220-240V	600 W	3 000 / 10 500	20 to 100 L	Wall
EMMAC001	EASY MIX BM MASTER WALL 220-240V	600 W	3 000 / 10 500	20 to 100 L	Wall
EMT003H	EASY MIX MASTER DMX 410.H FIXED 220-240V	600 W	3 000 / 10 500	20 to 100 L	Fixed
EMTAC001	EASY MIX BM MASTER FIXED 220-240V	600 W	3 000 / 10 500	20 to 100 L	Fixed
EMR003H	EASY MIX MASTER DMX 410.H ROLLING 220-240V	600 W	3 000 / 10 500	20 to 100 L	Rolling
EMRAC001	EASY MIX BM MASTER ROLLING 220-240V	600 W	3 000 / 10 500	20 to 100 L	Rolling

* For additional accessories, please refer to pages 32 / 33 of the catalogue.

Pictures are for illustrative purposes only.

EASYMIX

PROFESSIONAL SERIES

Effortless mixing, ultimate comfort!

DETACHABLE EQUIPMENT | 925 / 1 000 W | 4 TO 300 L

+ ADVANTAGES

+ VERSATILITY

Available in wall-mounted, mobile, or fixed versions.

+ COMFORT AND ERGONOMICS

Reduces musculoskeletal disorders thanks to an assistance arm.

+ HYGIENE

Designed with certified food-grade materials.

+ SAFETY

Includes an emergency and automatic stop.



WALL



FIXED



TO BE FIXED

ROLLING



Item code	Description	Output	Speed R.P.M.	Capacity	Serie
EMM001	EASY MIX SMX 800 TURBO WALL 220-240V	1 000 W	11 000	75 to 300 L	Wall
EMMAC052T	EASY MIX BM SMX TURBO WALL 220-240V	1 000 W	11 000	75 to 300 L	Wall
EMT001	EASY MIX SMX 800 TURBO FIXED 220-240V	1 000 W	11 000	75 to 300 L	Fixed
EMTAC052T	EASY MIX BM SMX TURBO FIXED 220-240V	1 000 W	11 000	75 to 300 L	Fixed
EMR001	EASY MIX SMX 800 TURBO ROLLING 220-240V	1 000 W	11 000	75 to 300 L	Rolling
EMRAC052T	EASY MIX BM SMX TURBO ROLLING 220-240V	1 000 W	11 000	75 to 300 L	Rolling

* For additional accessories, please refer to pages 36 / 37 of the catalogue.

Pictures are for illustrative purposes only.

RICER TOOL

PROFESSIONAL SERIES

Perfect mashed potatoes every time!

MONOBLOCK OR DETACHABLE EQUIPMENTS | 20 TO 100 KG

+ ADVANTAGES

+ ROBUSTNESS

Stainless steel foot.

+ HYGIENE

Tube and shaft 100% stainless steel for perfect hygiene.

+ SAFETY

Unlocking safety feature.



PP	300	520
Output	650 W	650 W
Total length	600 mm	870 mm
Weight / Packaged	3,1 kg / 4,1 kg	4,9 kg / 5,9 kg
Speed R.P.M	500	500
Item code	PP003	PP001

MONOBLOCK EQUIPMENT



**VARIABLE
SPEED**

450 mm



20 - 100 Kg

PP520 PLUS

Output	650 W
Total length	870 mm
Weight / Packaged	5,4 kg / 5,9 kg
Speed R.P.M	150 to 500
Item code	PP002

DETACHABLE EQUIPMENT



**VARIABLE
SPEED**



2 20 - 100 Kg



450 mm



3 40 - 100 L



690 mm

ACCESSORIES

ACCESSORIES AVAILABLE SEPARATELY

Item code	Description	
1 AC221	BM PP	Output 650 W
2 AC220	RICER TOOL PP	Speed R.P.M 150 / 500
3 AC208	FM PP	Speed R.P.M 150 / 500

TURBO LIQUIDIZER - GIGAMIX XS

PROFESSIONAL SERIES

Compact design, large capacity!

CONTACT US

for more information

TURBO LIQUIDIZER | 1,5 KW | 40 TO 150 L

+ ADVANTAGES

+ COMFORT

Enhanced maneuverability thanks to the brake wheels and easy to store due to its convenient size.

+ USABILITY

Compact, minimum space requirement.

+ HYGIENE

100% stainless steel for easy cleaning.

COMPLIANT WITH STANDARDS **CE**



Footprint drawing



GIGAMIX XS

BLENDER THREE-PHASED

BLENDER SINGLE-PHASED

Speed R.P.M	2 800	2 800
Voltage	400 V, three-phased + neutral, 50 Hz	230 V, single-phased, 50 Hz
Output	1,5 Kw	1,5 Kw
Item code	TB120	TB120.2



TURBO LIQUIDIZER - GIGAMIX

PROFESSIONAL SERIES

For your very large preparations.

CONTACT US

for more information

TURBO LIQUIDIZER | 2,2 KW | 40 TO 300 L

+ ADVANTAGES

+ COMFORT

Enhanced maneuverability thanks to the brake wheels.

+ VERSATILITY

Various accessories.

+ USABILITY

Easy storage.

+ HYGIENE

100% stainless steel for easy cleaning.

+ OUTPUT

Powerful motor of 2,2 KW.

+ PERFORMANCE

Time saving and maximum operating speed.



VARIABLE SPEED

OPTIONAL Variable speed control 2800 / 4000 R.P.M.

Option compulsory for single-phase. Factory installed only. Item code TB010

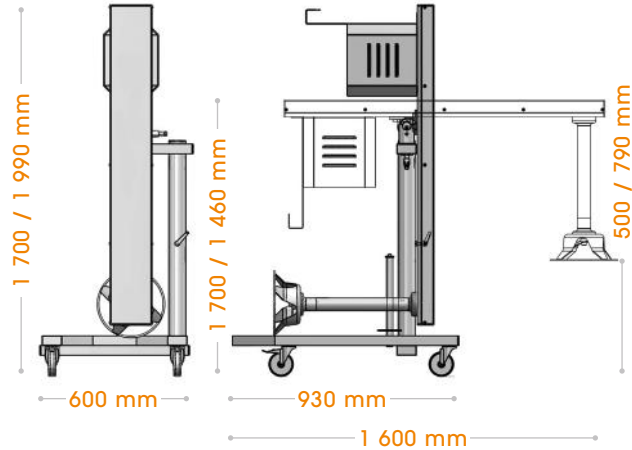

TURBO LIQUIDIZER

BELL INCLUDED

GIGAMIX STANDARD VERSION

Item code	Description	Output	Speed R.P.M.	Mixer attachment only	Voltage
TB001	GIGAMIX 460-500	2,2 Kw	4 000	570 mm	400 V, three-phased + neutral, 50 Hz
TB002	GIGAMIX 460-500 V.V variable speed included	2,2 Kw	2 800 / 4 000	570 mm	400 V, three-phased + neutral, 50 Hz*
TB002.2	GIGAMIX 460-500 + VAR 230V MONO	2,2 Kw	2 800 / 4 000	570 mm	230 V, single-phased
TB020	GIGAMIX BLENDER	2,2 Kw	4 000	570 mm	400 V, three-phased + neutral, 50 Hz
TB021	GIGAMIX BLENDER V.V variable speed included	2,2 Kw	2 800 / 4 000	570 mm	400 V, three-phased + neutral, 50 Hz*
TB021.2	GIGAMIX BLENDER + VAR. 230V MONO	2,2 Kw	2 800 / 4 000	570 mm	230 V, single-phased

TURBO LIQUIDIZER - GIGAMIX

PROFESSIONAL SERIES

CONTACT US

for more information



BELL INCLUDED

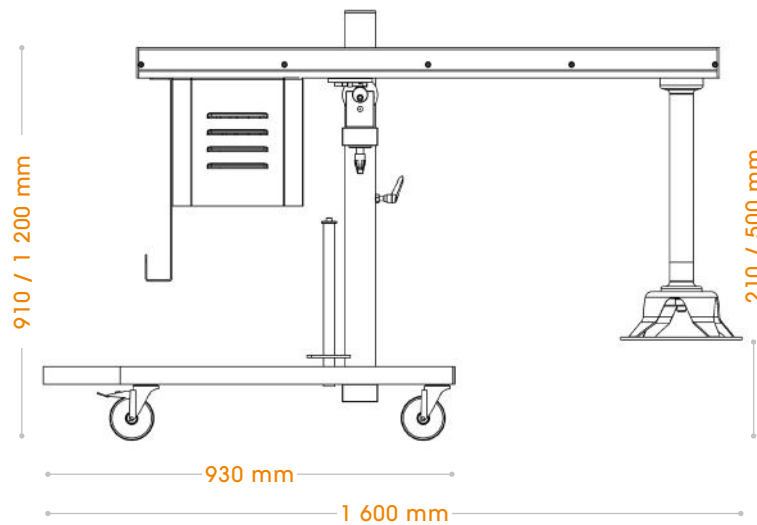

GIGAMIX LOWERED VERSION

Item code	Description	Output	Speed R.P.M.	Mixer attachment only	Voltage
TB005	GIGAMIX 460-210	2,2 Kw	4 000	570 mm	400 V, three-phased + neutral, 50 Hz
TB006	GIGAMIX 460-210 V.V variable speed included	2,2 Kw	2 800 / 4 000	570 mm	400 V, three-phased + neutral, 50 Hz*
TB006.2	GIGAMIX LOWERED + VAR 230V MONO	2,2 Kw	2 800 / 4 000	570 mm	230 V, single-phased
TB026	GIGAMIX LOWERED BLENDER + VAR 400V TRI + N	2,2 Kw	2 800 / 4 000	570 mm	400 V, three-phased + neutral, 50 Hz
TB026.2	GIGAMIX LOWERED BLENDER + VAR 230V MONO	2,2 Kw	2 800 / 4 000	570 mm	230 V, single-phased

TURBO LIQUIDIZER - GIGAMIX

PROFESSIONAL SERIES

CONTACT US

for more information



BELL INCLUDED

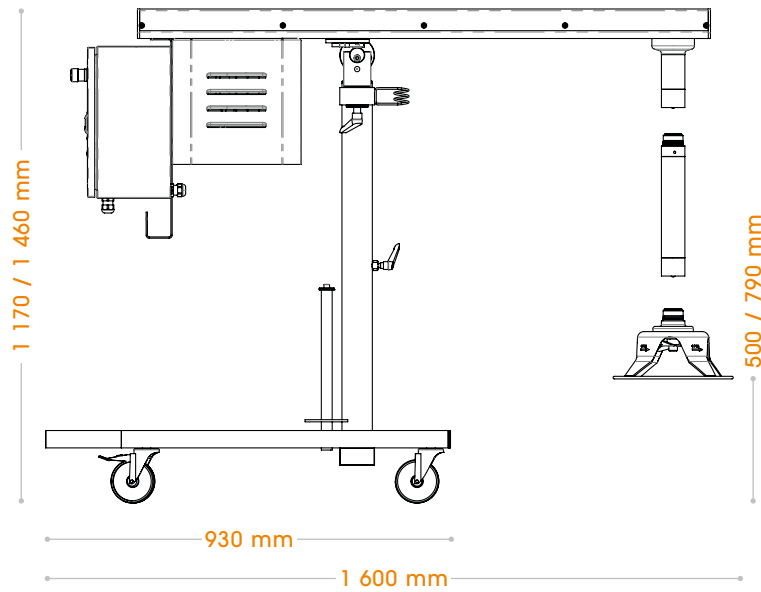

GIGAMIX REMOVABLE VERSION

Item code	Description	Output	Speed R.P.M.	Mixer attachment only	Voltage
TB008	GIGAMIX DMX	2,2 Kw	4 000	570 mm	400 V, three-phased + neutral, 50 Hz
TB009	GIGAMIX DMX V.V variable speed included	2,2 Kw	2 800 / 4 000	570 mm	400 V, three-phased + neutral, 50 Hz*
TB009.2	GIGAMIX DETACHABLE FOOT + VAR. 220-240V MONO	2,2 Kw	2 800 / 4 000	570 mm	230 V, single-phased
TB029	GIGAMIX DETACHABLE FOOT BLENDER + VAR. 400V TRI + N	2,2 Kw	2 800 / 4 000	570 mm	400 V, three-phased + neutral, 50 Hz
TB029.2	GIGAMIX DETACHABLE FOOT BLENDER + VAR. 220-240V MONO	2,2 Kw	2 800 / 4 000	570 mm	230 V, single-phased

TURBO LIQUIDIZER - GIGAMIX

TURBO LIQUIDIZER | 2,2 KW | 40 TO 300 L



1



2



3



4



5



6

ACCESSORIES

ACCESSORIES AVAILABLE SEPARATELY

Item code	Description	Speed R.P.M.	Lenght	Diameter
1 TB014	WHISK GIGAMIX variable speed compulsory	800 / 1 600	410 mm	170 mm
2 TB015	EXTENSION arm		300 mm	
3 TB012	MIXER TOOL GIGAMIX	2 800 / 4 000	300 mm	280 mm
4 TB004	BLENDER GIGAMIX	2 800 / 4 000	93 mm	98 mm
5 TB012.2	GIGAMIX BELL for bratt pan	2 800 / 4 000	133 mm	190 mm
6 TB013	POTATO TOOL MASHER variable speed compulsory	800 / 1 600	250 mm	165 mm

DYNAPUMP

Compatible with the blender attachment only.

Empty your pots in a few minutes !

With its innovative process, DYNAMIC transfer pump is perfectly adapted to the GIGAMIX blender attachment and allows the effortless and fast transfer of the mixed food preparation into packaging areas or to simply empty the pot quickly.

The DYNAPUMP allows to transfer between 40 and 60 liters per minute, depending on the viscosity of the liquid and the length of the hose used.



DYNAPUMP GIGAMIX

Adaptable to the blender attachment only

Diameter	178 mm
Item code	TB030



GIGAMIX GUN

Optional

Item code	TB040
-----------	-------



ELECTRIC COMBINED

PROFESSIONAL SERIES

With a wide selection of stainless steel discs.

UNTIL 300 KG PER HOUR, SUITABLE.
UNTIL 400 COVERS PER SERVICE.

+ ADVANTAGES

+ HYGIENE

All accessories are dishwasher safe.

+ COMFORT

Silent motor : 50Db without vibrations.

+ USABILITY

Designed to be used by right and left-handed.

+ PERFORMANCE

Increased productivity thanks to large discs
(largest diameter on the market).

COMPLIANT
WITH STANDARDS 



* Other voltages on request



Rated capacity
5,4 liters

CUTTER / CL
ELECTRIC



Digital display screen



COMBINE

2V

VV

VV SCREEN

V.S. Speed R.P.M.

320 & 640

320 to 720

320 to 720

F.P. Speed R.P.M.

1 500 & 3 000

350 to 3 500

350 to 3 500

Functions

Pulse & Reverse*

Pulse & Reverse*

Pulse & Reverse*, Timer*
& Countdown timer*

Output

1 100 W

1 100 W

1 100 W

Item code

CL312

CL322

CL350

* Food processor only.



ELECTRIC VEGETABLE SLICERS

PROFESSIONAL SERIES

With a wide selection of stainless steel discs.

UNTIL 300 KG PER HOUR, SUITABLE.
UNTIL 400 COVERS PER SERVICE.

+ ADVANTAGES

+ HYGIENE

All accessories are dishwasher safe.

+ COMFORT

Silent motor : 50Db without vibrations.

+ USABILITY

Designed to be used by right and left-handed.

+ PERFORMANCE

Increased productivity thanks to large discs
(largest diameter on the market).

COMPLIANT
WITH STANDARDS 



*Other voltages on request



1V



2V

VEGETABLE SLICER

Speed R.P.M	320
Output	1 100 W
Item code	CL100

Speed R.P.M	320 & 640
Output	1 100 W
Item code	CL110

Control panel



VV

Digital display screen



VV SCREEN

VEGETABLE SLICER

Speed R.P.M	320 to 720
Functions	Pulse & Reverse
Speed	5 levels
Output	1 100 W
Item code	CL121

Speed R.P.M	320 to 720
Functions	Pulse & Reverse, Timer & Countdown timer
Speed	5 levels
Output	1 100 W
Item code	CL150

ACCESSORIES

COMPLETE FOOD PROCESSOR KIT
Bowl, lid, smooth blade

Item code	CL9001
-----------	---------------



ELECTRIC TABLE TOP FOOD PROCESSOR

PROFESSIONAL SERIES

Emulsify, mix, and chop in a few seconds.

100 GR TO 4KG SUITABLE FOR
20 TO 100 COVERS PER SERVICE.

+ ADVANTAGES

+ HYGIENE

All accessories are dishwasher safe.

+ COMFORT

Silent motor : 50Db without vibrations.



*Other voltages on request



Delivered with standard knife

FOOD PROCESSOR



1V



2V

Speed R.P.M	1 500	1 500 & 3 000
Functions		Pulse & Reverse
Output	1 100 W	1 100 W
Item code	CL200	CL212

Control panel

Convertible into a vegetable slicer



VV

Digital display screen

Convertible into a vegetable slicer



VV SCREEN

FOOD PROCESSOR

Speed R.P.M	350 to 3 500	350 to 3 500
Functions	Pulse & Reverse	Pulse & Reverse, Timer & Countdown timer
Speed	10 levels	10 levels
Output	1 100 W	1 100 W
Item code	CL222	CL250

ACCESSORIES

STANDARD BLADE

Item code **CL8001**



SERRATED BLADE

Item code **CL8002**



MICRO-SERRATED BLADE

Item code **CL8003**



COMPLETE VEGETABLE SLICER

Cover, pusher handle, tray.

Item code **CL9000**



BLEND & MIX

PROFESSIONAL SERIES

Emulsify, mix, and chop in a few seconds.

100 GR TO 4KG SUITABLE FOR
20 TO 100 COVERS PER SERVICE.



ADVANTAGES

+ HYGIENE

All accessories are dishwasher safe.

+ COMFORT

Silent motor : 50Db without vibrations.





FUNCTION 2 IN 1

Ideal for soft diet preparations
Delivered with a standard blade
and a micro-serrated blade



**PATENTED
SYSTEM**



CUTTER / CL
ELECTRIC



BLEND & MIX

2V

VV

VV SCREEN

Speed R.P.M

1 500 & 3 000

350 to 3 500

350 to 3 500

Functions

Pulse & Reverse

Pulse & Reverse

Pulse & Reverse, Timer
& Countdown timer

Speed.

10 levels

10 levels

Output

1 100 W

1 100 W

1 100 W

Item code

CL412

CL422

CL450

*Other voltages on request



PACKS

DISCS AVAILABLE SEPARATELY

COLLECTIVE CATERING PACK

Item code **CL6003**

4 slicing discs : 0,5 mm, 2,5 mm, 5 mm & 11 mm

2 grating discs : 2 mm & 5 mm

2 julienne discs : 4x4 mm & 10x10 mm



BRASSERIE / CATERING PACK

Item code **CL6002**

3 slicing discs : 1,5 mm, 3 mm & 5 mm

1 grating disc : 2 mm

3 julienne discs : 4x4 mm, 8x8 mm & 10x10 mm



BUFFET PACK

Item code **CL6001**

3 slicing discs : 1,5 mm, 3 mm & 5 mm

1 grating disc : 2 mm



PIZZA PACK

Item code **CL6000**

2 slicing discs : 2,5 mm & 4 mm

1 grating disc : 5 mm



DISC SUPPORT

Adjustable unit table or wall disc support.

Item code **CL7000**



ACCESSORIES

DISCS AVAILABLE SEPARATELY

RIPPLE CUT

Item code

CL1030.W	3 mm
----------	------

NEW



Availability: 1st quarter of 2026

SLICING DISC

Item code

CL1005	0,5 mm
--------	--------

CL1015	1,5 mm
--------	--------

CL1025	2,5 mm
--------	--------

CL1030	3 mm
--------	------

CL1040	4 mm
--------	------

CL1050	5 mm
--------	------

CL1070	7 mm
--------	------

CL1080	8 mm
--------	------

CL1090	9 mm
--------	------

CL1110	11 mm
--------	-------

CL1120	12 mm
--------	-------

CL1130	13 mm
--------	-------



JULIENNE DISC

Item code

CL3032	3 x 2 mm
--------	----------

CL3042	4 x 2 mm
--------	----------

CL3044	4 x 4 mm
--------	----------

CL3055	5 x 5 mm
--------	----------

CL3052	5 x 2 mm
--------	----------

CL3088	8 x 8 mm
--------	----------

CL3010	10 x 10 mm
--------	------------



GRATING DISC

Item code

CL2002	2 mm
--------	------

CL2003	3 mm
--------	------

CL2005	5 mm
--------	------

CL2009	9 mm
--------	------



DICING SET

Item code

CL4008	8 x 8 mm
--------	----------

CL4010	10 x 10 mm
--------	------------

CL4016	16 x 16 mm
--------	------------



FRENCH FRIES SET

Item code

CL5008	8 x 8 mm
--------	----------



DYNACUBE

PROFESSIONAL SERIES

N°1 manual vegetable slicer in the world.

MANUAL VEGETABLE SLICER | 30 TO 50 KG/H

+ ADVANTAGES

+ FAST

Quick installation.

+ HYGIENE

Easy to clean.

+ COMFORT

Easy transport and storage.

+ VERSATILITY

Specific tools to allow different cuts.

+ SAFETY

No direct contact with the blade.





Item code	Description	Diameter	Total height	Weight / Packaged
CL007	DYNACUBE + KIT 1 grids 5,5 x 5,5 + pusher	400 mm	330 mm	3,1 / 4,4 Kg
CL006	DYNACUBE + KIT 2 grids 10 x 10 + pusher	400 mm	330 mm	3,1 / 4,4 Kg
CL003	DYNACUBE + KIT 3 grids 8,5 x 8,5 + pusher	400 mm	330 mm	3,1 / 4,4 Kg
CL009	DYNACUBE + KIT 4 grids 17 x 17 + pusher	400 mm	330 mm	3,1 / 4,4 Kg
CL008	DYNACUBE + KIT 5 grids 14 x 14 + pusher	400 mm	330 mm	3,1 / 4,4 Kg
CL005	DYNACUBE + KIT 6 grids 7 x 7 + pusher	400 mm	330 mm	3,1 / 4,4 Kg



KIT 1



KIT 2



KIT 3



KIT 4



KIT 5



KIT 6

KIT 1
grids 5,5 x 5,5
+ pusher

KIT 2
grids 10 x 10
+ pusher

KIT 3
grids 8,5 x 8,5
+ pusher

KIT 4
grids 17 x 17
+ pusher

KIT 5
grids 14 x 14
+ pusher

KIT 6
grids 7 x 7
+ pusher

Item code	AC065	AC062	AC061	AC064	AC063	AC060
-----------	-------	-------	-------	-------	-------	-------

SALAD SPINNERS

PROFESSIONAL SERIES

Registered models

COMPLIANT WITH STANDARDS



Indulge in the originals!

MANUAL & ELECTRIC | 5 TO 20 L

+ ADVANTAGES

+ COMFORT

100% watertight to avoid water leakage.

+ PERFORMANCE

Intensive use.

+ ROBUSTNESS

Gear with a stainless steel pin incorporated.



630 mm



20 L

EM98 ELECTRIC

Diameter	430 mm
Total height	630 mm
Weight / Packaged	8,3 kg / 10 kg
Output	200 W
Speed R.P.M.	500
Recommended for	3 to 5 lettuce heads
Item code	E003

WITH TIMEOUT

(Running time 1 min.)

Item code **E003.T**



Item code	
AC019	Stabilising base (E20 & E20 SC)
2815.1	Set of gears for both (E10 - E20)
2815.2	Set of gears (E20 SC)





250 mm

5 L

E5 SC MANUAL (SEALED COVER)

Diameter	275 mm
Total height	250 mm
Weight / Packaged	1,6 Kg
Recommended for	1 to 2 lettuce heads
Item code	E007



320 mm

10 L

E10 MANUAL*

Diameter	330 mm
Total height	320 mm
Weight / Packaged	2,4 Kg / 3 Kg
Recommended for	2 to 3 lettuce heads
Item code	E001



410 mm

20 L

E20 MANUAL*

Diameter	430 mm
Total height	410 mm
Weight / Packaged	3,6 Kg / 4,8 Kg
Recommended for	3 to 5 lettuce heads
Item code	E002



410 mm

20 L

E20 SC MANUAL (SEALED COVER) *

Diameter	430 mm
Total height	410 mm
Weight / Packaged	3,6 Kg / 4,8 Kg
Recommended for	3 to 5 lettuce heads
Item code	E004

VARIOUS

PROFESSIONAL SERIES

Ideal for effortlessly juicing a large quantity of citrus fruits.

100 TO 150 CITRUS FRUIT PER HOUR

+ ADVANTAGES

+ ROBUSTNESS

Quiet and very sturdy.

+ USABILITY

Easy and quick dismantling and re-assembling for easy cleaning.



Delivered with 2 juicing cones

DYNAJUICER

Lemons, oranges and grapefruit juicer.

Diameter	220 mm
Total height	330 mm
Output	200 W
Speed R.P.M	1 500
Weight	3,7 Kg
Item code	PA001



1 000 / 1 200 mm

FMA

90

91

Lenght	1 200 mm
Weight	1,1 Kg
Capacity	20 to 200 L
Item code	AC210

Lenght	1 000 mm
Weight	1,1 Kg
Capacity	20 to 200 L
Item code	AC211

PACKAGING

The packaging is also part of Dynamic merchandising.

Packaging is a powerful method to recognize the brand and identify the products.



DISPLAY RACK

A practical and great way to visually display Dynamic products.
(Please contact us for more information.)



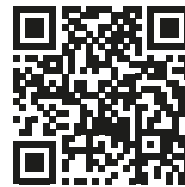

website

WEBSITE

www.dynamicmixers.com

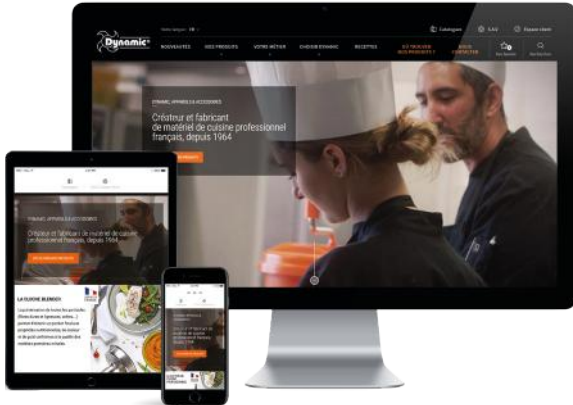

- + Photos and videos illustrating our products.
- + Download technical sheets and flyers.
- + Discover recipes with DYNAMIC equipment.
- + Contact us easily thanks to the complete contact form.

FOLLOW US

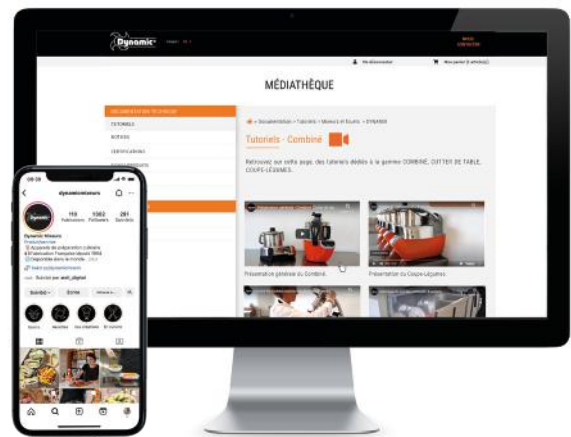

ONLINE STORE & CUSTOMER SERVICE

www.sav-dynamicmixers.com

By creating your Dynamic account, you will be able to :

- + Order the totality of our range (except Turbo liquidizer and Food processor / Electrical vegetal slicers) and our spare parts.
- + Access the media library and the professional space.
- + Watch tutorials.

CUSTOMER SERVICE

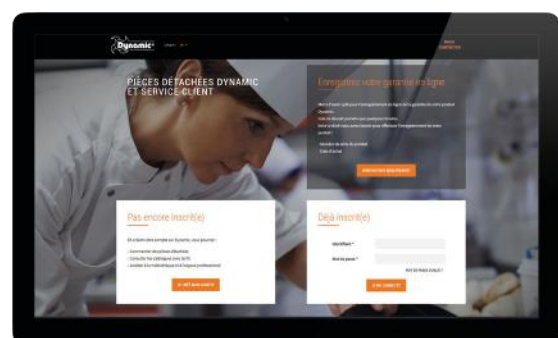

TO BE BY YOUR SIDE IN
TASTE INNOVATION



1 - GENERAL TERMS

In the absence of a special written agreement, all purchase orders imply the full and legal acceptance of these terms and conditions by the customer, notwithstanding any terms to the contrary that may feature in the customer's general purchase terms and conditions.

2 - ORDERS - QUOTES

Order only become final after written or tacit acceptance by DYNAMIC, hereafter referred to as "the Company". If a quote is provided, the order only becomes final after the quote is returned signed to the Company by letter, fax or any other means of transmission, within eight days of the quote being issued. Any changes to the order or the quote must be the subject of a written agreement between the Company and the customer.

3 - LEAD TIMES

Deliveries are made depending on supply and transport availability in the order in which the orders arrive, and according to the indications provided by the Company in its acceptance. The Company is authorised to make total or partial deliveries. Lead times are given for information and are not binding on the Company, especially in the event of force majeure or acts of God. No late delivery may entitle to the application of penalties or the payment of compensation, or deduction from the price or the cancellation of the order. In all cases, a customer shall only receive delivery if their situation relative to the Company is in order.

4 - DELIVERIES

Prices are given excluding VAT, FCA, packaging included. Unless there is a special indication in the order or the accepted quote, all orders are shipped with transport costs added. All the costs for express delivery are fully payable by the customer who requests this service. The goods become the property of the customer when they leave the Company shop floor, on condition of the application of the ownership clause below. Consequently all transport, customs, insurance and handling operations are at the customer's expense and at their risks and perils. The customer must make sure the delivery is compliant and check for possible damage and missing items and, where applicable, issue the necessary reserves to the relevant organisations and transporters by registered letter with acknowledgement of receipt within 72 hours. The customer shall notify the Company of this.

5 - RETURNS

Any product returns must be the subject of a prior formal agreement between the Company and the customer. If accepted, 10% will be deducted for costs. Special orders cannot be returned.

6 - WARRANTY

The Company is bound to deliver goods that are compliant with the contract and shall respond to compliance faults that are found on delivery. To be compliant with the contract, the goods must:

- Be fit for the purpose expected of a similar item and, where applicable, correspond to the description given by the Company and have the properties that the Company presented to the customer in the form of a sample or model;
- Have the characteristics that a customer may legitimately expect considering the claims made by the Company, especially in advertising;
- Or have the characteristics mutually defined between the parties;

- Or be fit for any special purpose sought by the customer, made known to the Company and accepted by the Company; Electric appliances have a one year manufacturing defect warranty starting from the purchase date. The warranty covers all parts and labour. The warranty covers the replacement of any defective parts but does not cover damage from dropping or impacts, damage caused by improper use, incorrect connection to the power supply, or the failure to follow the usage conditions described in the instructions.

7 - PRICE

The prices and information featuring in the catalogues or other Company printed advertising material are only binding on the Company, which reserves the right to make any changes to the sizes, materials or weights of the products presented or described, without any duty to modify products previously delivered or of which the order is ongoing. Goods are invoiced on the basis of the price applicable at the time of the order. Payments are made to the Company headquarters. Unless special terms are agreed, orders are payable in full on shipment of the goods. A discount of 0.5% per full month, generating a proportional reduction in VAT, shall be granted on the total amount excluding VAT in the event of early payment. Any other terms of payment must be the subject of a prior agreement. On failure to pay on the contractual due date, late payment penalties equal to 3 times the legal interest rate shall be due automatically and without notice, starting from the 1st day late. Furthermore, a fixed compensation for debt recovery costs of 40 euros shall be due automatically and without notice. If the debt recovery costs are higher than this amount, additional compensation shall be due on presentation of proof. The Company may also suspend any further deliveries.

8 - OWNERSHIP

The Company retains full ownership of the sold goods until full payment by the customer. However, the risks of loss, theft or deterioration of the goods are exclusively borne by the customer as soon as the goods are made available to them. The failure to pay a term may lead to a claim for existing goods.

9 - COPYRIGHT

The drawings, models, plans and quotes, and more generally all types of document issued by the Company carry the exclusive copyright of the Company; they may not be communicated or performed without its written authorisation. They must be returned on request by the Company.

10 - RENOUNCEMENT

No late delivery, omission or any tolerance by the Company in the exercise of one of its rights resulting from this agreement shall be construed as a renouncement by the Company to the exercise of that right.

11 - JURISDICTION

In the event of a dispute, the Company and the customer in question shall undertake arbitration out of court by a single arbitrator, chosen mutually or, failing this, appointed on request from the most diligent party by the President of the Roche-sur-Yon commercial court. The parties renounce all right of appeal against the decision of the arbitrator which shall be final, and undertake to obey the decision without proceedings or exequatur.



Distributed by:



Please contact the nearest office
for any additional information

DYNAMIC FRANCE

Société d'études et réalisations mécaniques dite DYNAMIC
518 rue Léo Baekeland, ZI du Puy Nardon
BP 57 - 85290 Mortagne-sur-Sèvre / FRANCE
Tel. +33 (0)2 51 63 02 72 / e-mail : contact@dynamicmixers.com
Siret : SAS - 416450435 - RCS La Roche-sur-Yon : 416 45

A NEW ALTERNATIVE FOR YOUR
PREPARATIONS DYNAMIC®
www.dynamicmixers.com



Document non contractuel - Dans un souci d'évolution, nos produits et accessoires peuvent être modifiés.
Création catalogue & photos : STUDIO HV - studiohv.fr - RCS ANGERS B382 910 651 / Imprimé en France / Crédits Photos : STUDIO HV / Styliste culinaire : Alexandra Pasi / Agence A'loil / Adobe Stock.



GRUPE
DYNAMIC
MORTAGNE SUR SEVRE