



PROFESSIONAL
SERIES
2024

60



YEARS
OF EXPERTISE

Since 1964

dynamicmixers.com

Dynamic celebrates **60 YEARS** *of excellence!*

1964

Establishment of the mechanical engineering company known as DYNAMIC in Monaco. Manufacturing and marketing of juicers.

1992

Invention of the high-capacity 20L salad spinner.

1995

Introduction of the "little sister" - launching of the 10L model.

2002

Opening of a second subsidiary in Germany.



1966

Relocation of the company to Vence (06). DYNAMIC gradually specializes in blending and invents the professional mixers.

1974

Beginning of the marketing in Europe, starting with the United Kingdom, ...

1982

DYNAMIC joins the Cholet-based NADIA GROUP.

2000

Establishment of the Canadian subsidiary responsible for the North American market (USA, CANADA). Marketing of the DYNACUBE, the number one manual cutter worldwide.

2001

Administrative management and a part of the production is transferred from Vence (06) to Mortagne-sur-Sèvre (85).

DYNAMIC marks its 60th anniversary by celebrating six decades of commitment to excellence. Today, more than half a century after its establishment, DYNAMIC stands as one of the world's most recognized and respected brands among professional chefs. Established through its subsidiaries in Germany and Canada since the early 2000s, and present in over 120 countries, DYNAMIC has gained global acclaim for the durability of its products and its unique MADE IN FRANCE expertise.

Our strength : A human-sized company, artisanal expertise built upon experienced men and women, and a constant pursuit of innovation.

Our goal : to provide robust, high-performing, and innovative equipment to meet chefs and cooks' high expectations in their professional environment.

60 years by your side to share our values and our commitment to excellence. The story is far from over; we will continue to nurture this shared spirit of determination to build a strong future together. We want to express our heartfelt gratitude for your presence by our side for the past 60 years!

2015

Introduction of the homogenizing blender tool to the market.

2019

Launch of table top food processors & vegetable slicers range.



2009

Launch of the TURBO LIQUIDIZER range for high quantity preparations.

2016

Launch of the DYNAMIX NOMAD, the only wireless professional mixer.

2020

The 5L salad spinner completes the manual salad spinner product range.

2021

Closure of the Vence (06) site. All production is now located in Mortagne-sur-Sèvre (85).

NEW

The Dynamix® is getting a makeover **IN 2024,**
in celebration of its **60TH ANNIVERSARY.**





**The acclaimed Franco-Australian pastry chef
Richard HAWKE places his trust in us.**

His top choice from DYNAMIC®: The MD95 hand blender with variable speed.

Why? The MD95 is ideal for the emulsion technique, a fundamental aspect of pastry. It features an emulsifying blade (4 blades, including one curved) that streamlines the emulsification process. The potency of its motor with variable speed enables effective and swift work.

Thanks to him!



Expertise



Since 1964

Committed to preserving French expertise, fostering local employment, and maintaining its production facilities in France, DYNAMIC designs and manufactures its mixers, salad spinners, vegetable slicers, and other product lines in Mortagne-sur-Sèvre, Vendée.



Across these two sites covering over 6000 square meters, 75% of the manufactured appliances are electric, while 25% are manual. DYNAMIC has an integrated production process and selects the finest materials to ensure high-quality, reliable, and robust appliances.



R & D

Assembly

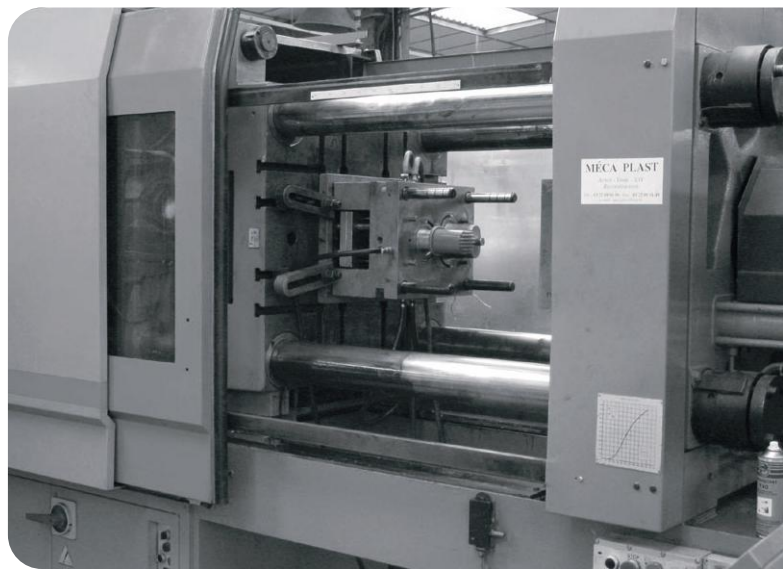

Injection

Customer Service

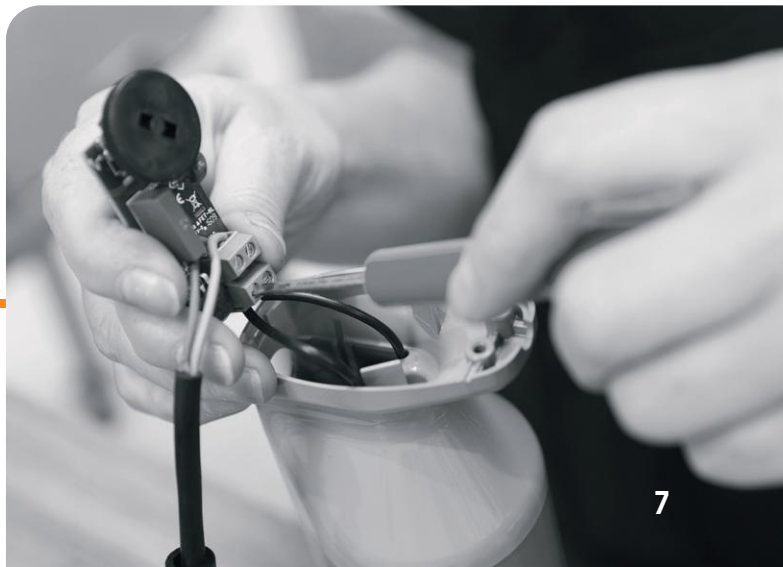

COMMITTED *to the future*

Aware of its responsibility for the future, NADIA GROUP (650 employees), of which DYNAMIC is a part, has been committed to a Corporate Social Responsibility (CSR) approach since 2021.

Our goal is to contribute to sustainable development by embracing effective practices that consider the social, environmental, and economic effects of our actions.



Designed to be **REPAIRED**

Our products are designed to be easily repairable, disassembled, and reassembled. DYNAMIC is committed to ensuring that its products are repairable for 10 years in France and worldwide, and guarantees the immediate availability of spare parts.

A rigorous renewal and stock monitoring process ensures quick supply to every customer around the world. All spare parts are manufactured in our production sites according to the standards set by the RoHS Directive, which stipulates the non-use of harmful substances.

Certified **PRODUCTS**

All products manufactured in our facilities in Mortagne sur Sèvre (85) comply with the essential requirements of IEC, CE, and NSF standards.

These stringent quality requirements in terms of safety and standardization ensure that each user receives consistently high-performing, quality products.



The CE marking is a symbol of quality, safety, and reliability. It ensures that an independent authority has verified the compliance of our products with regulatory requirements, allowing for their free circulation throughout the EU territory.



Certification to NSF standards provides proof that our equipment complies with the requirements of the 'US FDA FOOD CODE'.



The IEC standard defines requirements, specifications, guidelines, or characteristics to which systematic adherence ensures that materials, products, processes, and services can be used safely and are suitable for their intended purpose.





Warrantied **PRODUCTS**

Each DYNAMIC product comes with an instruction and warranty manual. In this document, you will find all our guidance for starting, using, and maintaining your appliance to ensure their long-lasting usage.

Dynamic, a committed **COMPAGNY**



Recyclable **PRODUCTS**

DYNAMIC has implemented in France a take-back and treatment system for end-of-life electrical and electronic equipment (WEEE), in accordance with the provisions of Decree No. 2012/19/CE of July 4, 2012.

This applies, as stipulated by the decree, to equipment introduced to the market after August 13, 2005. The cost of end-of-life equipment processing is included in the sales prices. For more information, please contact DYNAMIC France.

Our products are recyclable, and each site is equipped with a collection and recycling protocol.

An eco-responsible **POLICY**

DYNAMIC is committed to an eco-responsible policy from the sourcing of its purchases to waste management:



By favoring
geographical
proximity



Through
dematerialization



Through
eco-design



Through waste
sorting
and valorization



+ THAN 50 EMPLOYEES

*are committed to providing you
with a unique expertise*



Expertise 100%
French since
1964



Global
network

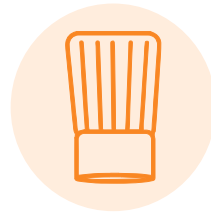

Recommended by
professionals



Culture of
innovation

25%

are manual

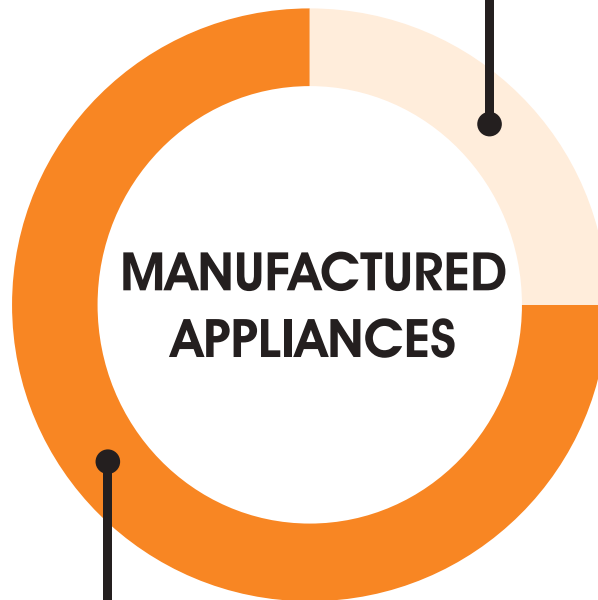

75%

are electric

Dynamic is represented
in **+ 120 COUNTRIES**

2 PRODUCTION *sites*



FRANCE

Tel. +33 (0)2 51 63 02 72
contact@dynamicmixers.com

518 rue Léo Baekeland
BP57 - 85290 Mortagne-sur-Sèvre FRANCE
www.dynamicmixers.com

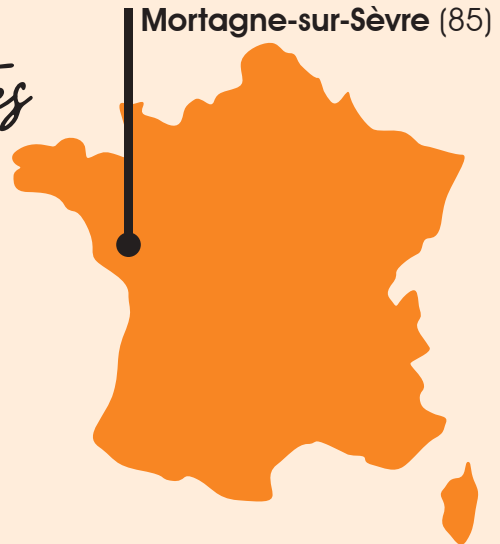

NORTH AMERICA

USA / Canada

Tel. : +1-800-267-7794 - +1-514-956-0127
Fax : +1-877-668-6623 - +1-514-956-8983
info@dynamicmixers.com



Canada

Montreal, Quebec
3227 Boul. pitfield - H4S-1H3
www.dynamicmixers.ca



USA

1320 route 9 # 1352
Champlain, NY - 12919
www.dynamicmixersusa.com



GERMANY

Eine starke Marke
der NADIA GROUP GMBH

Tel. +49 (0)7851 886 45-0
Fax +49 (0)7851 886 45-32
info@dynamic-professional.de

Robert-Koch-Strasse 7
77694 Kehl
www.dynamic-professional.de

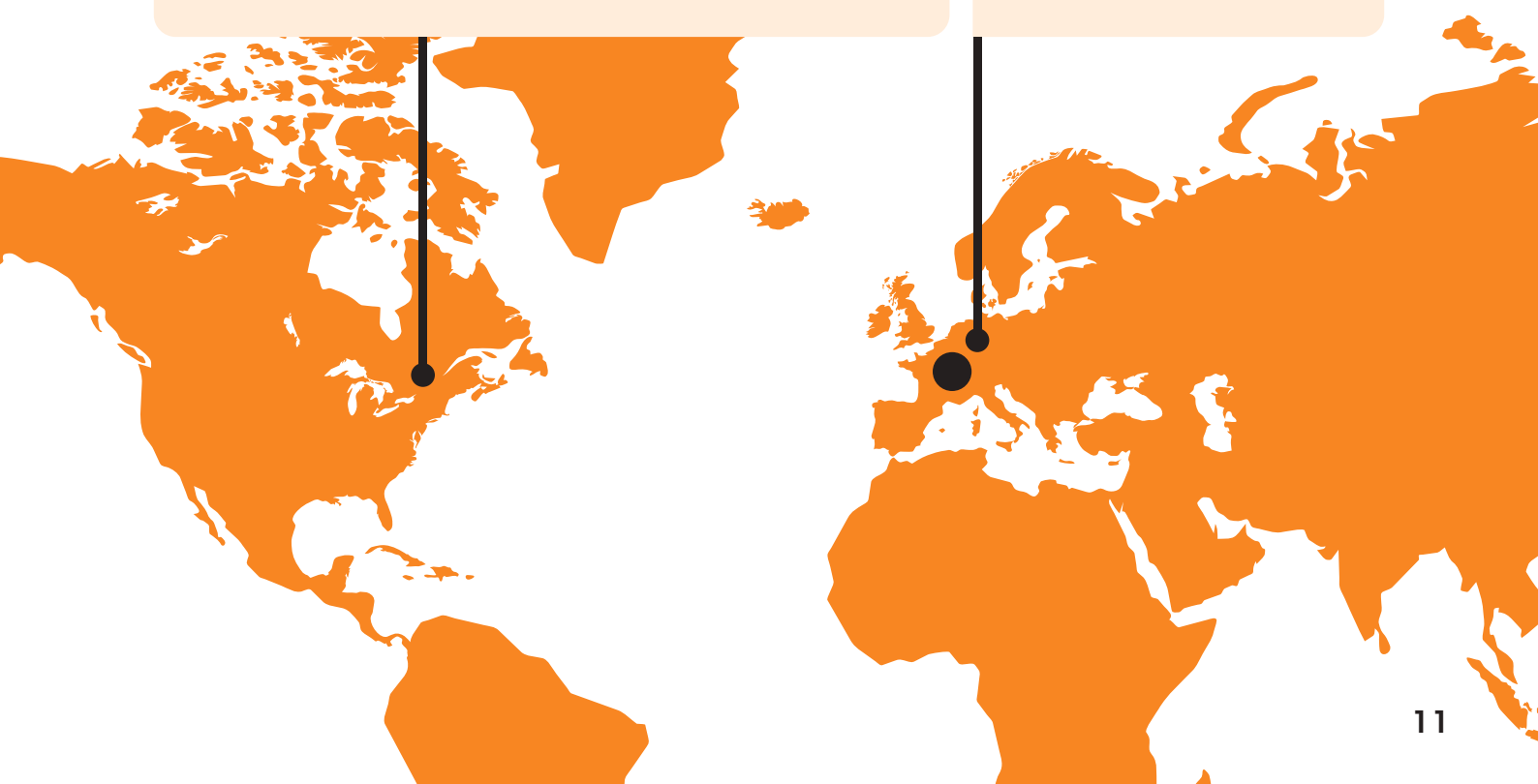

S E R I E S

PROFESSIONAL SERIES

*For your
professions*

COMMERCIAL CATERING



Dynamix® Series	PAGE 18 to 25
Junior Series	PAGE 26 to 29
Electrical vegetable slicer range	PAGE 52 to 55

Food processor range	PAGE 56
Dynacube Series	PAGE 58
Salad spinner Series	PAGE 60

COLLECTIVE CATERING



Master Series	PAGE 34 to 39
SMX Series	PAGE 40 to 43
Ricer tool Series	PAGE 44
Turbo liquidizer Series	PAGE 46 to 51

Electrical vegetable slicer range	PAGE 52 to 55
Food processor range	PAGE 56
Salad spinner Series	PAGE 60

BAKERS & PASTRY CHEFS



Mini MD95 Series	PAGE 16
Dynamix® Series	PAGE 18 to 25
Junior Series	PAGE 26 to 29

CHOCOLATE MAKERS & ICE CREAM MAKERS



Mini MD95 Series	PAGE 16
Dynamix® Series	PAGE 18 to 25
Junior Series	PAGE 26 to 29

BUTCHERS & CATERERS



Dynamix® Series	PAGE 18 to 25	Food processor range	PAGE 56
Junior Series	PAGE 26 to 29	Dynacube series	PAGE 58
Master Series	PAGE 34 to 39	Salad spinner Series	PAGE 60
Electrical vegetable slicer range	PAGE 52 to 55		

Since 1964
60 YEARS *of expertise*



Table of contents

PROFESSIONAL CATALOGUE 2024

Since 1964	p. 2
Our expertise and commitment	p. 6
Global network	p. 10
Our ranges for your professions	p. 12
Mini MD95	p. 16
Dynamix® DMX	p. 18
Dynamix® Nomad	p. 20
Dynamix® DMX V2	p. 22
Accessories & Packs Dynamix®	p. 24
Junior	p. 26
Accessories & Packs Junior	p. 29
Senior	p. 30
Accessories & Packs Senior	p. 33
Master	p. 34
Accessories & Packs Master	p. 39
SMX	p. 40
SMX accessories	p. 43
Ricer tool	p. 44
Turbo liquidizer	p. 46
Turbo liquidizer accessories	p. 50
Combined & Vegetable Slicers	p. 52
Accessories & Packs	p. 54
Table top food processor & Blend&Mix	p. 56
Manual vegetable slicer	p. 58
Salad spinners	p. 60
Various	p. 62
Mixers supports	p. 64
News, online store & Customer Service	p. 66
General sales conditions	p. 67

MINI MD95

PROFESSIONNAL SERIES

MONOBLOCK EQUIPMENT | 250 W | 1 to 8 L



Recommended by the famous
chocolate school VALRHONA.

*A small and robust
appliance.*

ADVANTAGES

Robustness

Monobloc, stainless steel attachment, and stainless steel blades with Titanium coating. Ultra-resistant, optimizing its durability over time for intensive use

Safety

Unlocking safety feature.

Usability

Enhanced usability is provided by its ergonomic grip and perfectly balanced weight, thanks to high-tech materials

Hygiene

Stainless steel immersion tube and bell for perfect hygiene

Knife

2 or 4 blades.



Dynamic, partner of Alexis SOSZYNSKI
Worldskills 2022

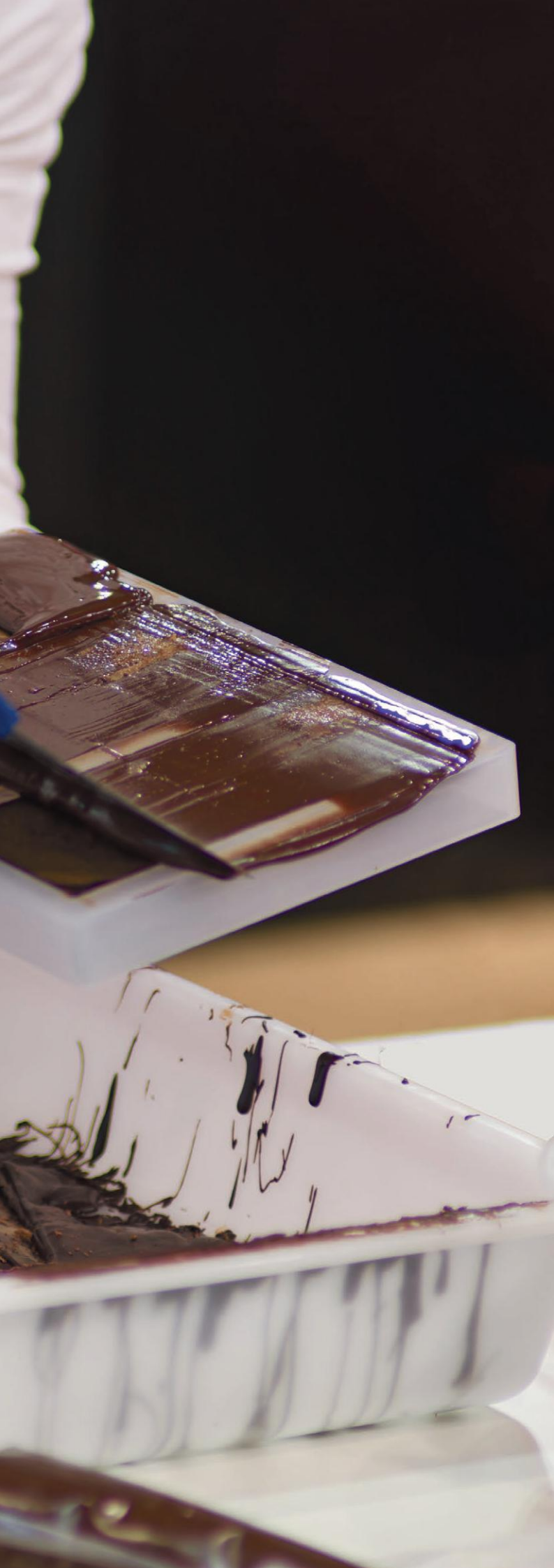

..... 160 mm



Variable speed
 optional

Knife	4 blades / 2 blades
Output	250 W
Total length	445 mm
Shaft length	160 mm
Bell diameter	55 mm
Weight / Packaged	1,2 kg / 1,5 kg
Speed R.P.M	11 500
Item code	MX008 / MX010

DYNAMIX

PROFESSIONAL SERIES

DETACHABLE EQUIPMENT | 220 / 250 W | 1 to 8 L



*Specially designed
for small preparations,
sauces, and emulsions.*

+ ADVANTAGES

- + Performance**
Special tools for a smooth mix.
- + Robustness**
Stainless steel foot.
- + Usability**
Quickly accessible speed control.
- + Hygiene**
Detachable mixer tool, tube and bell 100% in stainless steel for easy cleaning.
- + Comfort**
Lightness for easy use.
- + Versatility**
Various accessories, whisk, Dynacutter bowl, ricer tool, Blender accessory.

Dynamix® DMX 160 Blender



Variable speed

160 mm



Hammer	Star-shaped
Output	220 W
Total length	395 mm
Shaft length	160 mm
Bell diameter	35 mm
Weight / Packaged	1,2 kg / 1,5 kg
Speed R.P.M	3 000 to 13 000
Item code	MX100

Dynamix® DMX 160



Variable speed

160 mm



Knife	2 blades
Output	220 W
Total length	395 mm
Shaft length	160 mm
Bell diameter	55 mm
Weight / Packaged	1 kg / 1,2 kg
Speed R.P.M	3 000 to 13 000
Item code	MX050

Dynamix® DMX 190



Variable speed

190 mm



Knife	4 blades
Output	250 W
Total length	425 mm
Shaft length	190 mm
Bell diameter	66 mm
Weight / Packaged	1 kg / 1,5 kg
Speed R.P.M	3 000 to 13 000
Item code	MX090

N O M A D

PROFESSIONAL SERIES

DETACHABLE EQUIPMENT | 2 000 mAh 12 Vdc | 1 to 8 L

OPERATING TIME
25
MINUTES



*Wireless, the freedom
of movement
in the kitchen.*



ADVANTAGES

- + Performance**
Special tools for a smooth mix.
- + Robustness**
Stainless steel foot.
- + Hygiene**
Detachable mixer tool, tube and bell 100%
in stainless steel for easy cleaning.

COMPLIANT
WITH STANDARDS



Dynamix® Nomad 160*



160 mm



Dynamix® Nomad 190*



190 mm



Knife	2 blades
Output	2 000 mAh 12Vdc
Total length	450 mm
Tube length + bell	160 mm
Bell diameter	55 mm
Weight / Packaged	1,1 kg / 1,9 kg
Speed R.P.M	10 000
Item code	MX130

Knife	2 blades
Output	2 000 mAh 12Vdc
Total length	480 mm
Tube length + bell	190 mm
Bell diameter	66 mm
Weight / Packaged	1,5 kg / 2,2 kg
Speed R.P.M	10 000
Item code	MX140

* Others accessories (except blender) available separately.



Compact size and low battery weight for effortless work. Quick and easy replacement.



Delivered with a charger lithium-ion battery. (Charging time 45 minutes)

Charger

Item code

AC590

Battery

Item code

AC585

DYNAMIX® V2

PROFESSIONNAL SERIES

DETACHABLE EQUIPMENT | 220 / 250 W | 1 to 8 L



*Two speeds
for ultra-fast
adjustment.*

ADVANTAGES

- + Performance**
2 speeds (8 000 rpm and 13 000 rpm).
- + Robustness**
Stainless steel foot.
- + Hygiene**
Detachable mixer tool, tube and bell 100% in stainless steel for easy cleaning.
- + Comfort**
Lightness for easy use.
- + Versatility**
Various accessories, whisk, Dynacutter bowl, ricer tool, Blender accessory.

Available in 3 colors

orange color in standard



Dynamix® 160 V2

Orange / Black

Item code

MX055

Red / Black

Item code

MX056

White / Black

Item code

MX057

Dynamix® 190 V2

Orange / Black

Item code

MX095

Red / Black

Item code

MX096

White / Black

Item code

MX097

Dynamix® DMX 160 V2*



Knife	2 blades
Output	220 W
Total length	395 mm
Shaft length	160 mm
Bell diameter	55 mm
Weight/ Packaged	1 kg / 1,2 kg
Speed 1 R.P.M	8 000
Speed 2 R.P.M	13 000
Item code	According to colors

Dynamix® DMX 190 V2*



Knife	2 blades
Output	250 W
Total length	425 mm
Shaft length	190 mm
Bell diameter	66 mm
Weight / Packaged	1,2 kg / 1,5 kg
Speed 1 R.P.M	8 000
Speed 2 R.P.M	13 000
Item code	According to colors

* Others accessories available separately.

Accessories and packs

Accessories available separately.

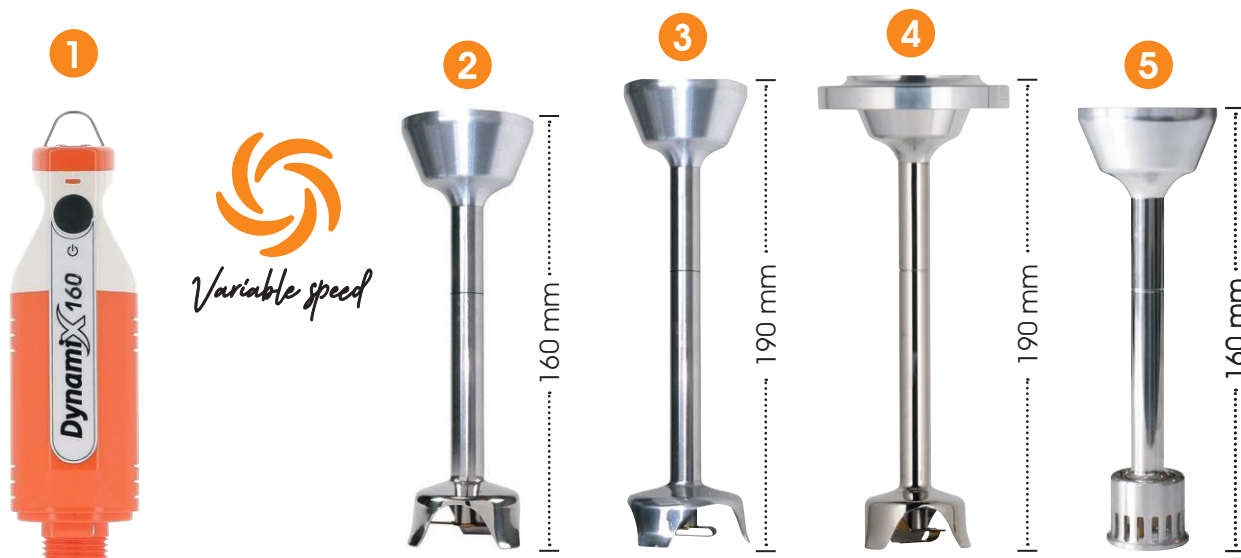

1 BM Dynamix®

Output

BM 160
220 W

BM 190
250 W

Item code

AC515

AC514



2 blade
knife



4 blade
knife

8



Skimmer
disc



Beater
disc

2 M160

Knife

2 blades

Speed R.P.M

3 000 / 13 000

Mixer head diameter

55 mm

Item code

AC521

Capacity

1 to 4 liters

3 M190

4 blades

3 000 / 13 000

66 mm

AC550

1 to 8 liters

4 M Shake 190

Adaptable with
the graduated bowl

4 blades

3 000 / 13 000

66 mm

AC530

1 to 8 liters

5 Blender Dynamix®

Speed R.P.M

3 000 / 13 000

Item code

AC560

Capacity

1 to 4 liters

6 Whisk Dynamix®

600 / 2 500

AC516

1 to 4 liters

7 Ricer tool

70 / 300

AC517

1 to 5 kg

8 Blade pack

-

AC540

-

Extractable
whisks

6



Exclusive
product

7

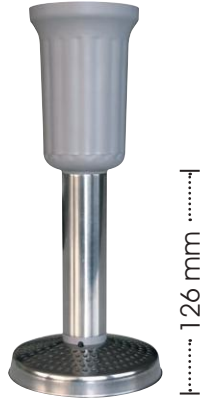

9



Reverse
blades



10



11



9 Cutter bowl
Dynamix®

10 Graduated bowl
Dynamix®

11 Stainless steel jug
Dynamix®

Speed R.P.M

Item code

Capacity

600 / 2 500

AC518

-

-

AC510

1 liter

-

AC513

3 liters



1 + 2 + 6

Dynamix®
Combi 160

1 Motor block

1 Mixer tool

Knife

1 Whisk tool

Item code

220 W

160 mm

2 blades

185 mm

MF052

1 + 2 + 6 + 7

Dynamix® Trio 160

1 Motor block

1 Mixer tool

Knife

1 Whisk tool

1 Ricer tool

Item code

220 W

160 mm

2 blades

185 mm

126 mm

MF050

JUNIOR

PROFESSIONNAL SERIES

MONOBLOCK EQUIPMENT | 270 W | 1 to 25 L



*The lightest on the market
in its category.*

+ ADVANTAGES

- + Performance**
Special tools for a smooth mix.
- + Robustness**
Stainless steel foot.
- + Usability**
Variable speed easily switchable.
- + Hygiene**
Detachable mixer tool, tube and bell 100% in stainless steel for easy cleaning.
- + Comfort**
Lightness for easy use.
- + Versatility**
Various accessories, whisk, Dynacutter bowl, ricer tool, Blender accessory.
- + Safety**
Unlocking safety feature.



Junior MX 225



Variable speed
optional

225 mm



Knife	2 blades
Output	270 W
Total length	505 mm
Shaft length	225 mm
Weight / packaged	1,7 kg / 2 kg
Speed R.P.M	12 000
Item code	MX020 / MX020.V

Junior Whisk



Variable speed

185 mm



Output	270 W
Total length	500 mm
Shaft length	185 mm
Weight / Packaged	1,4 kg / 1,7 kg
Speed R.P.M	300 to 2 000
Item code	FT005

JUNIOR

PROFESSIONNAL SERIES

DETACHABLE EQUIPMENT | 270 W | 1 to 25 L



BM Junior



Variable speed

Output
Item code

270 W
AC100



Accessories and packs

Accessories available separately.



	1	2	3	4	5	6
	M225	M300	Blender Junior	Whisk Junior	Ricer tool Junior	Cutter bowl Junior
Speed R.P.M	3 000 / 12 000	3 000 / 12 000	3 000 / 12 000	600 / 2 500	70 / 300	600 / 2 500
Capacity	5 to 25 liters	5 to 25 liters	1 to 10 liters	1 to 5 liters	1 to 10 kg	0,8 liters
Item code	AC101	AC105	AC066	AC102	AC103	AC104



Junior COMBI 225

1 Motor block	270 W
1 Mixer tool	225 mm
Knife	2 blades
1 Whisk tool	185 mm
Item code	MX022



Junior DMX 225

1 Motor block	270 W
1 Mixer tool	225 mm
Knife	2 blades
Item code	MX021.V



Junior DMX 225 Blender

1 Motor block	270 W
Blender 225 mm	
Star shaped hammer	
Item code	MX110

SENIOR

PROFESSIONNAL SERIES

DETACHABLE EQUIPMENT | 350 W | 20 to 40 L



*An ideal solution
for traditional
and collective catering.*



ADVANTAGES

- + Performance**
Special tools for a smooth mix.
- + Robustness**
Stainless steel foot.
- + Usability**
Variable speed easily switchable.
- + Hygiene**
Detachable accessories for easy cleaning.
- + Comfort**
Lightness for easy use.
- + Versatility**
Various accessories, whisk, Dynacutter bowl, ricer tool.
- + Safety**
Unlocking safety feature.





Senior MX 300



Variable speed
optional

300 mm



Knife	3 blades
Output	350 W
Total length	600 mm
Shaft length	300 mm
Weight / Packaged	2,4 kg / 2,9 kg
Speed R.P.M	9 500
Item code	MX007 / MX007.V

COMPLIANT WITH STANDARDS



SENIOR

PROFESSIONAL SERIES

DETACHABLE EQUIPMENT | 350 W | 5 to 40 L



BM Senior



Variable speed

Output
Item code

350 W
AC005

Accessories and packs

Accessories available separately.

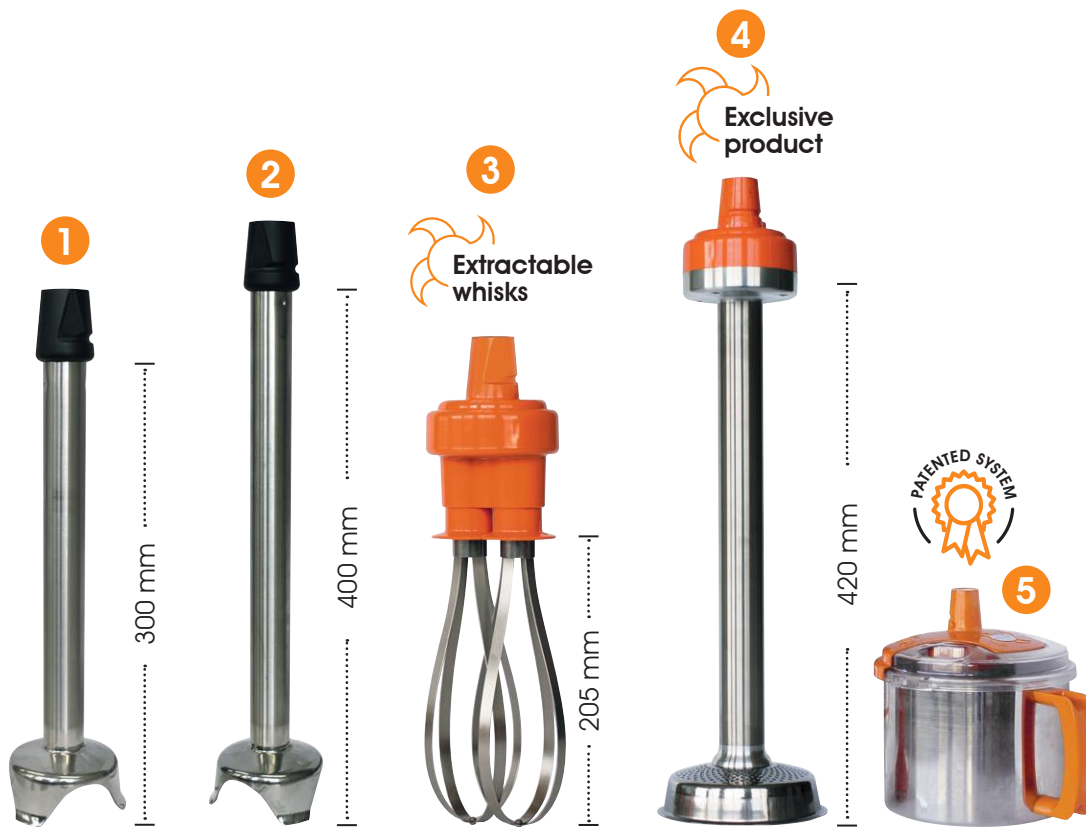

	1	2	3	4	5
	M300	M400	Whisk Senior	Ricer tool Senior	Cutter bowl inox Senior
Speed R.P.M	2 800 / 9 500	2 800 / 9 500	300 / 900	100 / 600	400 / 1 500
Capacity	20 to 40 liters	20 to 40 liters	5 to 20 liters	10 to 15 kg	5 liters
Item code	AC006	AC016	AC007	AC004	AC055



Senior COMBI 300

- 1 Motor block
- 1 Mixer tool
- Knife
- 1 Whisk tool
- Item code

350 W
300 mm
3 Blades
205 mm
MF003



Senior DMX 300

- 1 Motor block
- 1 Mixer tool
- Knife
- Item code

350 W
300 mm
3 blades
MX006

MASTER

PROFESSIONAL SERIES

MONOBLOCK EQUIPMENT | 600 W | 5 to 100 L



+ ADVANTAGES

+ Performance

Special tools for a smooth mix.

+ Robustness

Stainless steel foot.

+ Usability

Variable speed easily switchable.

+ Hygiene

Detachable foot and bell without tools, tube and bell 100% in stainless steel for easy cleaning.

+ Comfort

Lightness for easy use.

+ Versatility

Various accessories, whisk, Dynacutter bowl, ricer tool, blender foot.

+ Safety

Unlocking safety feature.

COMPLIANT
WITH STANDARDS

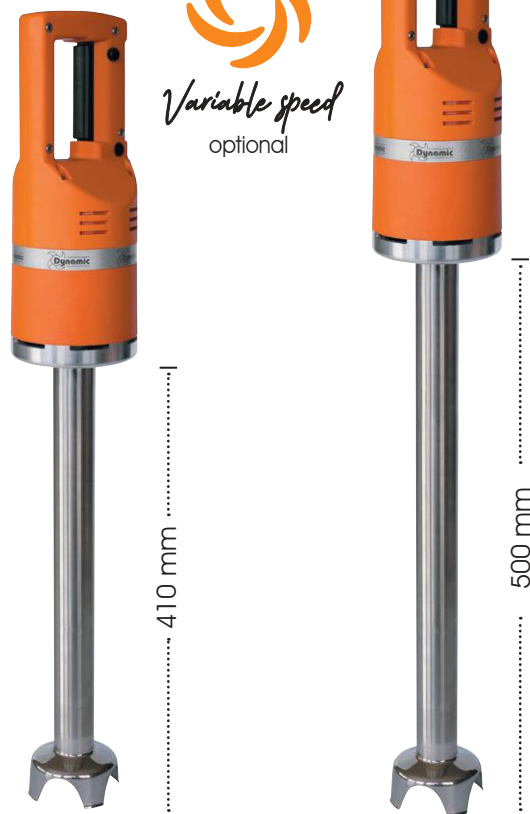

Master MX 91-410



Knife	3 blades
Output	600 W
Total length	715 mm
Shaft length	410 mm
Weight / Packaged	3,4 kg / 3,8 kg
Speed R.P.M	10 500
Item code	MX005 / MX005.V

Master MX 91-500



Knife	3 blades
Output	600 W
Total length	800 mm
Shaft length	500 mm
Weight / Packaged	3,6 kg / 4 kg
Speed R.P.M	10 500
Item code	MX045 / MX045.V

Master MX 410



..... 410 mm



Variable speed
optional



Knife	3 blades
Output	600 W
Total length	720 mm
Shaft length	410 mm
Weight / Packaged	3,5 kg / 4,1 kg
Speed R.P.M	10 500
Item code	MX004 / MX004.V

Master Whisk



..... 245 mm



Variable speed



Output	600 W
Total length	650 mm
Length. Whisk	245 mm
Weight / Packaged	3,3 kg / 3,7 kg
Speed R.P.M	300 to 900
Item code	FT001

MASTER

PROFESSIONAL SERIES

DETACHABLE EQUIPMENT | 600 W | 5 to 100 L



Clean ^{UP} **System**

Fully removable mixer foot and bell

For easy cleaning, maintenance and perfect hygiene. All stainless steel for increased durability of your attachment. Dishwasher proof. This DYNAMIC exclusive system complies with HACCP requirements.

Packs

Accessories available separately.



1 Motor block
1 Mixer tool
Knife
1 Whisk tool
1 Ricer tool
Item code

1 + 2 + 3

Master Combi 410.H

600 W
410 mm
3 blades
245 mm
-

MF002.H

1 + 2 + 3 + 4

Master Trio 410.H

600 W
410 mm
3 blades
245 mm
420 mm

MF001.H



Master DMX 410 Blender

1 Motor block
1 Mixer tool
Hammer
Item code

600 W
410 mm
Star shaped
MX120



Master DMX 410.H

1 Motor block
1 Mixer tool
Knife
Item code

600 W
410 mm
3 blades
MX003.H



MASTER

PROFESSIONAL SERIES



BM Master



Variable speed

Output
Item code

600 W
AC001

Accessories

Accessories available separately.

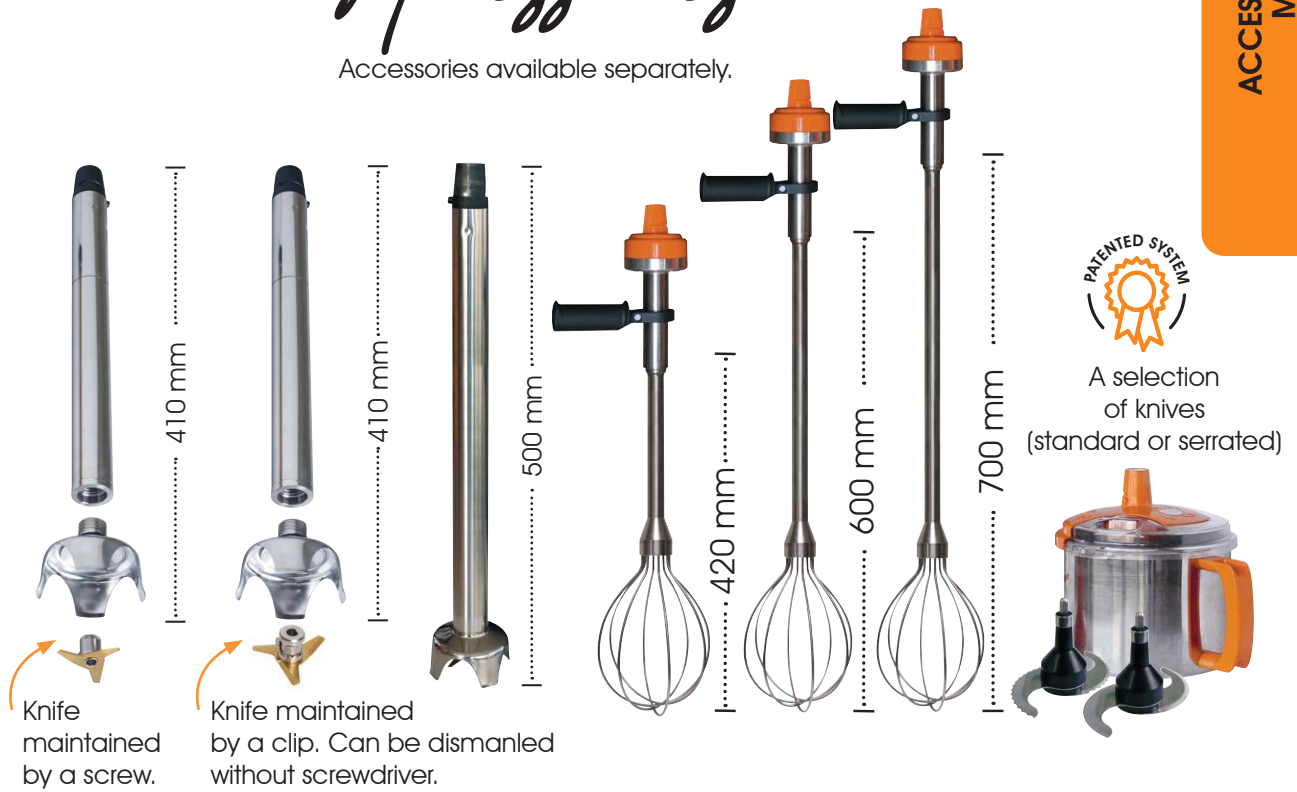

	M410.H	M410.HC	M500	FM420	FM600	FM700	Cutter bowl
Speed R.P.M	3 000 / 10 500	3 000 / 10 500	3 000 / 10 500	100 / 600	100 / 600	100 / 600	400 / 1 500
Capacity	20 to 100 L	20 to 100 L	20 to 100 L	20 to 200 L	20 to 200 L	20 to 200 L	5 L
Item code	AC002.H	AC002.HC	AC500	AC202	AC200	AC201	AC055

Exclusive product

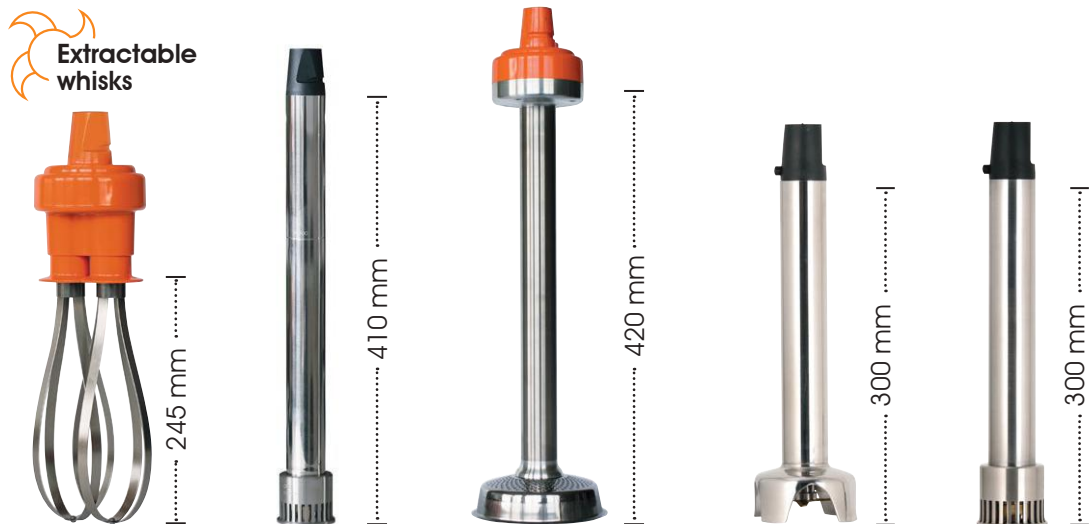

	Whisk Master	Blender Master	Ricer tool Master	M300 CC Master	Blender CC Master
Speed R.P.M	300 / 900	3 000 / 10 500	100 / 600	3 000 / 10 500	3 000 / 10 500
Capacity	5 to 20 liters	5 to 40 liters	10 to 30 kg	20 to 100 liters	5 to 40 liters
Item code	AC003	AC070	AC004	AC260.HC	AC265

SMX

PROFESSIONAL SERIES

MONOBLOCK / DETACHABLE EQUIPMENT
850 / 1000 W | 75 to 300 L



*Heavy-duty, designed
for communities.*



ADVANTAGES

- + Performance**
Special tools for a smooth mix.
- + Robustness**
Stainless steel foot.
- + Hygiene**
Completely removable foot and bell without tools.
Tube and bell 100% stainless steel for easy cleaning.
- + Comfort**
Easy use thanks to its support.
- + Safety**
Unlocking safety feature.
- + Output**
New motorization for a better output.

COMPLIANT WITH STANDARDS



SMX 600 Turbo

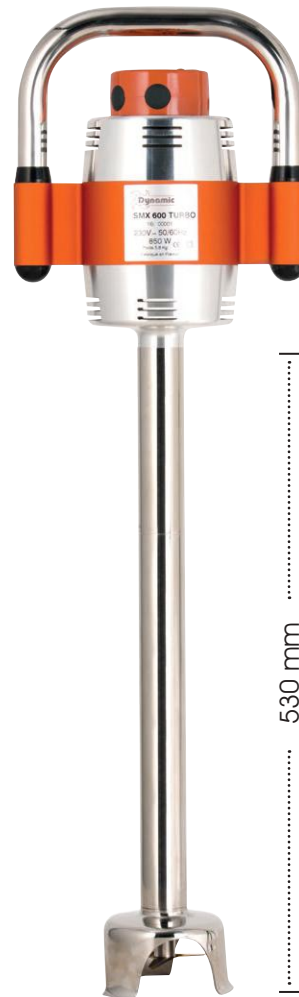

Knife	3 blades
Output	850 W
Total length	800 mm
Shaft length	530 mm
Weight / Packaged	6,1 kg / 7,7 kg
Speed R.P.M	11 000
Item code	MX002T



SMX 700 Turbo

SMX 800 Turbo

SMX Blender Turbo

Knife
Output
Total length
Shaft length
Weight / Packaged
Speed R.P.M
Item code

3 blades
925 W
870 mm
600 mm
6,5 kg / 8 kg
11 000
MX040T

3 blades
1 000 W
960 mm
680 mm
6,7 kg / 8,2 kg
11 000
MX001T

Star shaped hammer
1 000 W
860 mm
580 mm
6,7 kg / 8,2 kg
11 000
MX125T

SMX

PROFESSIONAL SERIES

DETACHABLE EQUIPMENT | 1000 W | 75 to 300 L



BM SMX Turbo



Output
Item code

1 000 W
AC052T

COMPLIANT
WITH STANDARDS



Accessories

Accessories available separately.

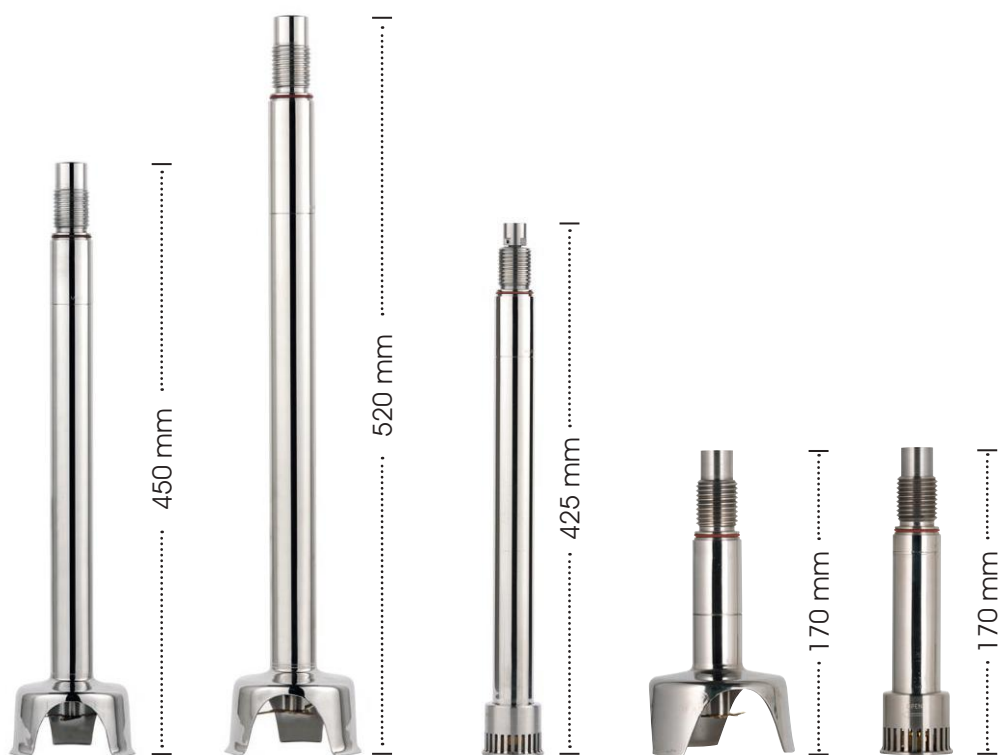

	Attachment 700 Turbo	Attachment 800 Turbo	Blender SMX Turbo	M300 CC SMX Turbo	Blender CC SMX Turbo
Speed R.P.M	11 000	11 000	11 000	11 000	11 000
Item code	AC075T	AC076T	AC072T	AC250T	AC255T

RICER TOOL

PROFESSIONAL SERIES



ADVANTAGES

- + Robustness**
Stainless steel foot.
- + Hygiene**
In compliance with HACCP recommendations.
- + Safety**
Unlocking safety feature.

MONOBLOCK EQUIPMENT 20 to 100 kg



	PP520	PP300
Output	650 W	650 W
Total length	870 mm	600 mm
Weight / Pack.	4,9 kg / 5,9 kg	4,7 kg / 5,7 kg
Speed R.P.M	500	500
Item code	PP001	PP003

DETACHABLE EQUIPMENT
20 to 100 kg



Variable speed



PP520 plus

Output **650 W**
 Total length **870 mm**
 Weight / Pack. **4,9 kg / 5,9 kg**
 Speed R.P.M **150 to 500**
 Item code **PP002**

Accessories

Accessories available separately.



Variable speed



BM PP

Output **650 W**
 Item code **AC221**



Ricer tool PP

Speed R.P.M **150 / 500**
 Item code **AC220**



FM PP

Speed R.P.M **150 / 500**
 Item code **AC208**

GIGAMIX XS

PROFESSIONAL SERIES

TURBO LIQUIDIZER | 1,5 / 2,2 Kw
40 to 300 L

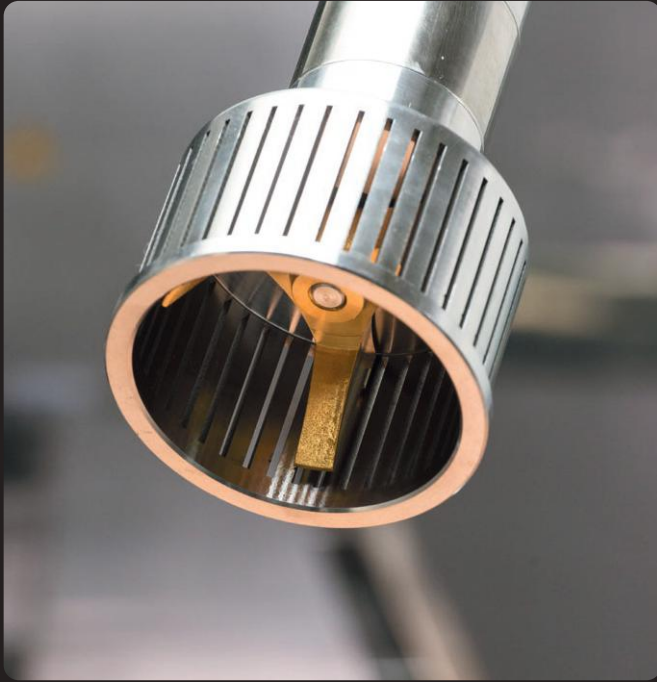

*Compact design,
large capacity!*



ADVANTAGES

- + Comfort**
Enhanced maneuverability thanks to the brake wheels and easy to store due to its convenient size.
- + Usability**
Compact, minimum space requirement.
- + Hygiene**
100% stainless steel for easy cleaning.

COMPLIANT
WITH STANDARDS 

CONTACT US
for more information

Footprint drawing



**Gigamix XS Blender
Three-phased**

**Gigamix XS Blender
Single-phased**

Speed R.P.M
Voltage
Output
Item code

2 800
400 V, three-phased + neutral, 50 Hz
1,5 Kw
TB120

2 800
230 V, single-phased, 50 Hz
1,5 Kw
TB120.2

GIGAMIX

PROFESSIONAL SERIES



For your very large preparations.



ADVANTAGES

- + Comfort**
Enhanced maneuverability thanks to the brake wheels.
- + Versatility**
Various accessories.
- + Usability**
Easy storage.
- + Hygiene**
100% stainless steel for easy cleaning.
- + Output**
Powerful motor of 2,2 KW.
- + Performance**
time saving and maximum operating speed.



Variable speed

OPTIONAL Variable speed control
2800 / 4000 R.P.M.
Option compulsory for single-phase.
Factory installed only. Item code
TB010



CONTACT US
for more information

Footprint drawing



Standard Version

	Gigamix 460-500	Gigamix 460-500 V.V Variable speed included	Gigamix Blender	Gigamix Blender V.V Variable speed included
Mixer attachment only	570 mm	570 mm	570 mm	570 mm
Speed R.P.M	4 000	2 800 / 4 000	4 000	2 800 / 4 000
Voltage*	400 V, three-phased + neutral, 50 Hz	400 V, three-phased + neutral, 50 Hz*	400 V, three-phased + neutral, 50 Hz	400 V, three-phased + neutral, 50 Hz*
Output	2,2 Kw	2,2 Kw	2,2 Kw	2,2 Kw
Item code	TB001	TB002	TB020	TB021

Lowered Version

Removable Version

	Gigamix 460-210	Gigamix 460-210 V.V Variable speed included	Gigamix DMX	Gigamix DMX V.V Variable speed included
Mixer attachment only	570 mm	570 mm	570 mm	570 mm
Speed R.P.M	4 000	2 800 / 4 000	4 000	2 800 / 4 000
Voltage*	400 V, three-phased + neutral, 50 Hz	400 V, three-phased + neutral, 50 Hz*	400 V, three-phased + neutral, 50 Hz	400 V, three-phased + neutral, 50 Hz*
Output	2,2 Kw	2,2 Kw	2,2 Kw	2,2 Kw
Item code	TB005	TB006	TB008	TB009

* Other voltages on request

Accessories

Accessories available separately.



Speed R.P.M
Length
Diameter
Item code

1 Whisk Gigamix
Variable speed compulsory

800 / 1 600
410 mm
170 mm

TB014

2 Blender Gigamix

2 800 / 4 000
93 mm
98 mm

TB004

Speed R.P.M
Length
Diameter
Item code

3 Mixer tool Gigamix

2 800 / 4 000
133 mm
280 mm

TB012

4 Potato tool masher
Variable speed compulsory

800 / 1 600
250 mm
165 mm

TB013

Length
Item code

5 Gigamix bell for bratt pan

300 mm

TB012.2

6 Extension arm

-

TB015

Dyna pump

With its innovative process, DYNAMIC transfer pump is perfectly adapted to the GIGAMIX blender attachment and allows the effortless and fast transfer of the mixed food preparation into packaging areas or to simply empty the pot quickly.

The DYNAPUMP allows to transfer 100 liters of water (for information, the viscosity of water is equal to 1 centipoise) in 1 minute at maximum speed (4000 rpm)



Gigamix gun
Optional

Item code

TB040



Dynapump Gigamix
Adaptable to the blender attachment only

Diameter

178 mm

Item code

TB030

Empty your pots in a few minutes !

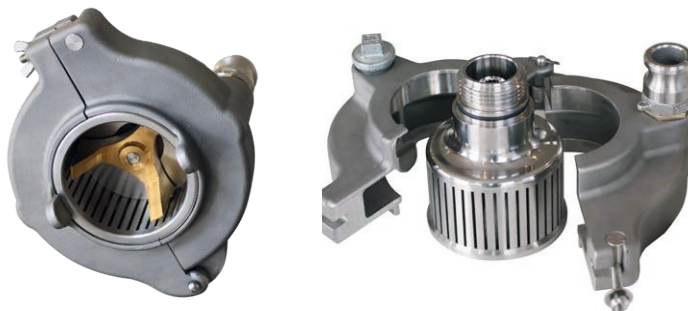

Compatible with the blender attachment only.

COMBINED & VEGETABLE SLICERS

PROFESSIONAL SERIES

UNTIL 300 KG PER HOUR, SUITABLE
FOR 400 COVERS PER SERVICE



*With a wide selection
of stainless steel discs.*

+ ADVANTAGES

- + Hygiene**
All accessories are dishwasher safe
- + Comfort**
Silent motor : 50Db without vibrations
- + Usability**
Designed to be used by right
and left-handed
- + Performance**
increased productivity thanks to large discs
(largest diameter on the market)

COMPLIANT
WITH STANDARDS **CE**





Operating capacity : 4.3 liters
Rated capacity : 5.4 liters

	Combined 2 Speeds	Combined Variable Speed	Combined VS Digital display screen
Vegetable Slicer Speed R.P.M.	320 & 640	320 to 720	320 to 720
Food Processor Speed R.P.M.	1 500 & 3 000	350 to 3 500	350 to 3 500
Functions	Pulse & Reverse*	Pulse & Reverse*	Pulse, Reverse*, Timer*, Countdown timer*
Output	1 100 W	1 100 W	1 100 W
Item code	CL312	CL322	CL350

* Food processor only.



	Vegetable slicer 1 Speed	Vegetable slicer 2 Speeds	Vegetable slicer VS Control panel	Vegetable slicer VS Screen Digital display screen
Speed R.P.M	320	320 and 640	320 to 720	320 to 720
Functions	-	-	Pulse	Pulse
Speed	-	-	5 levels	5 levels
Output	1 100 W	1 100 W	1 100 W	1 100 W
Item code	CL100	CL110	CL121	CL150

Accessories

Accessories available separately.



Slicing disc

Item code

CL1005	0,5 mm
CL1015	1,5 mm
CL1025	2,5 mm
CL1030	3 mm
CL1040	4 mm
CL1050	5 mm
CL1070	7 mm
CL1080	8 mm
CL1090	9 mm
CL1110	11 mm
CL1120	12 mm
CL1130	13 mm

Julienne disc

Item code

CL3032	3x2 mm
CL3042	4x2 mm
CL3044	4x4 mm
CL3055	5x5 mm
CL3052	5x2 mm
CL3088	8x8 mm
CL3010	10x10 mm



Grating disc

Item code

CL2002	2 mm
CL2003	3 mm
CL2005	5 mm
CL2009	9 mm

Dicing set

Item code

CL4008	8x8 mm
CL4010	10x10 mm

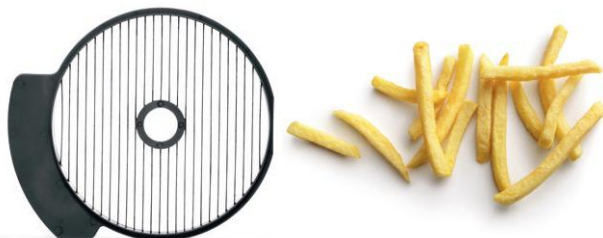
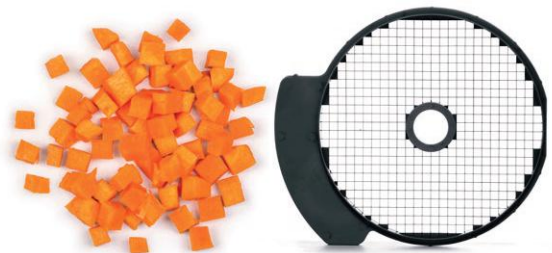

French fries set

Item code

CL5008	8x8 mm
--------	--------

Disc support Adjustable unit table or wall disc support

Item code **CL7000**



Packs

Accessories available separately.

Complete Vegetable Slicer kit Cover, pusher handle, tray.

Item code

CL9000



Complete food processor kit Bowl, lid, smooth blade

Item code

CL9001



Collective Catering PACK

- + 4 slicing discs : 0,5 mm, 2,5 mm, 5 mm and 11 mm
- + 2 grating discs : 2 mm and 5 mm
- + 2 julienne discs : 4x4 mm and 10x10 mm

Item code

CL6003



Brasserie / Catering PACK

- + 3 slicing discs : 1,5 mm, 3 mm and 5 mm
- + 1 grating disc : 2 mm
- + 3 julienne discs : 4x4 mm, 8x8 mm and 10x10 mm

Item code

CL6002



Buffet PACK

- + 3 slicing discs : 1,5 mm, 3 mm and 5 mm
- + 1 grating disc : 2 mm

Item code

CL6001



Pizza PACK

- + 2 slicing discs : 2,5 mm and 4 mm
- + 1 grating disc : 5 mm

Item code

CL6000

TABLE TOP FOOD PROCESSOR
BLEND & MIX
— PROFESSIONAL SERIES

FROM 100G TO 4KG, SUITABLE
FOR 20 TO 100 COVERS
PER SERVICE



*Emulsify, mix,
and chop
in a few seconds.*

+ **ADVANTAGES**

- + Hygiene**
All accessories are dishwasher safe
- + Comfort**
Silent motor : 50Db without vibrations





Delivered with standard knife

	Food Processor 1 Speed	Food Processor 2 Speeds	Food Processor VS Control panel Convertible into a vegetable slicer	Food Processor VS Screen Digital display screen Convertible into a vegetable slicer
Speed R.P.M	1 500	1 500 & 3 000	350 to 3 500	350 to 3 500
Functions	-	Pulse & Reverse	Pulse & Reverse	Pulse & Reverse, timer & countdown timer
Speed	-	-	10 levels	10 levels
Output	1 100 W	1 100 W	1 100 W	1 100 W
Item code	CL200	CL212	CL222	CL250



FUNCTION 2 IN 1

Ideal for soft diet preparations
Delivered with a standard blade and a micro-serrated blade

	Blend & Mix 2V	Blend & Mix VV Control panel	Blend & Mix VV Screen Digital display screen
Speed R.P.M	1 500 & 3 000	350 to 3 500	350 to 3 500
Functions	Pulse & Reverse	Pulse & Reverse	Pulse & Reverse, timer & countdown timer
Speed	-	10 levels	10 levels
Output	1 100 W	1 100 W	1 100 W
Item code	CL412	CL422	CL450

Accessories



Standard blade

Item code **CL8001**



Serrated blade

Item code **CL8002**



Micro-serrated blade

Item code **CL8003**

DYNACUBE

PROFESSIONAL SERIES

MANUAL VEGETABLE SLICER

30 to 50 kg/H



*N°1
manual
vegetable slicer
in the world.*



ADVANTAGES

- + Fast**
Quick installation.
- + Hygiene**
Easy to clean.
- + Comfort**
Easy transport and storage.
- + Versatility**
Specific tools to allow different cuts.
- + Safety**
No direct contact with the blade.

COMPLIANT
WITH STANDARDS 



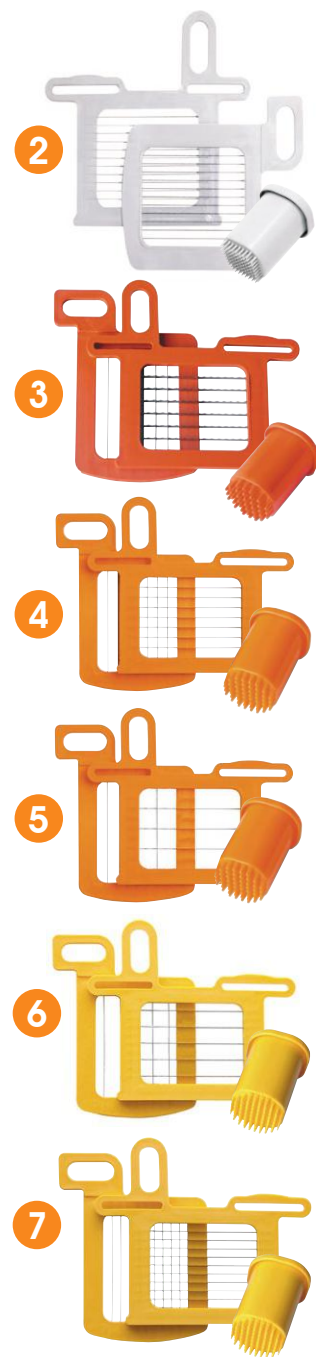

	1 + 2	1 + 7	1 + 4	1 + 3	1 + 6	1 + 5
	Dynacube	Dynacube	Dynacube	Dynacube	Dynacube	Dynacube
	+ grids 5,5x5,5 + pusher	+ grids 7x7 + pusher	+ grids 8,5x8,5 + pusher	+ grids 10x10 + pusher	+ grids 14x14 + pusher	+ grids 17x17 + pusher
Diameter	400 mm	400 mm	400 mm	400 mm	400 mm	400 mm
Total height	330 mm	330 mm	330 mm	330 mm	330 mm	330 mm
Weight / Packaged	3,1 / 4,4 kg	3,1 / 4,4 kg	3,1 / 4,4 kg	3,1 / 4,4 kg	3,1 / 4,4 kg	3,1 / 4,4 kg
Item code	CL007	CL005	CL003	CL006	CL008	CL009

	2	7	4	3	6	5
	Kit grids 5,5x5,5 + pusher	Kit grids 7x7 + pusher	Kit grids 8,5x8,5 + pusher	Kit grids 10x10 + pusher	Kit grids 14x14 + pusher	Kit grids 17x17 + pusher
Item code	AC065	AC060	AC061	AC062	AC063	AC064

SALAD SPINNERS

PROFESSIONAL SERIES

MANUAL & ELECTRIC | 5 to 20 L



*Indulge
in the originals!*

Registered models



ADVANTAGES

+ Hygiene

Anti-bacterial incorporated,
complies with HACCP requirements.

+ Comfort

100% watertight to avoid water leakage.

+ Performance

Intensive use.

+ Robustness

Gear with a stainless steel pin incorporated.

COMPLIANT
WITH STANDARDS



EM98 Electric



With timeout
(running time 1 min)

Item code **E003.T**

Diameter	430 mm
Total height	630 mm
Weight / Packaged	8,3 kg / 10 kg
Output	200 W
Speed R.P.M	500
Recommended for	3 to 5 lettuce heads
Item code	E003



Item code

Stabilising base
(E20 & E20 SC)

AC019

Set of gears for both
(E10 - E20)

2815.1

Set of gears (E20 SC)

2815.2

E5SC Manual

Sealed cover



Diameter	275 mm
Total height	342 mm
Weight / Packaged	1,6 kg
Recommended for	1 to 2 lettuce heads
Item code	E007

E10 Manual*



Diameter	330 mm
Total height	420 mm
Weight / Packaged	2,4 kg / 3 kg
Recommended for	2 to 3 lettuce heads
Item code	E001

E20 Manual*



Diameter	430 mm
Total height	500 mm
Weight / Packaged	3,6 kg / 4,8 kg
Recommended for	3 to 5 lettuce heads
Item code	E002

E20 SC Manual*

Sealed cover



Diameter	430 mm
Total height	500 mm
Weight / Packaged	3,6 kg / 4,8 kg
Recommended for	3 to 5 lettuce heads
Item code	E004

VARIOUS

PROFESSIONAL SERIES

100 TO 150 CITRUS FRUIT PER HOUR



Ideal for effortlessly juicing a large quantity of citrus fruits.



ADVANTAGES

- + Robustness**
Quiet and very sturdy.
- + Usability**
Easy and quick dismantling and re-assembling for easy cleaning.



Dynajuicer

Lemons, oranges and grapefruit juicer.



Delivered with 2 juicing cones

Diameter	220 mm
Total height	330 mm
Output	200 W
Speed R.P.M	1 500
Weight	3,7 kg
Item code	PA001



| 1000 / 1200 mm |

	Manual whisk FMA 90	Manual whisk FMA 91
Length	1 200 mm	1 000 mm
Weight	1,1 kg	1,1 kg
Capacity	20 to 200 liters	20 to 200 liters
Item code	AC210	AC211



Dynamic

SMX 800 TURBO

15/ 00902

230V ~ 50/60Hz

1000 W

Poids 6.1 Kg

Fabriqu  en France



Supports



Pan support brackets
(For your safety and your comfort.)

	SM 4	SM 6	SM 8	SM 10	SM 12	SA
Weight	1,9 kg	2,3 kg	2,6 kg	2,8 kg	3,2 kg	0,7 kg
Diameter	400 mm	600 mm	800 mm	1 000 mm	1 200 mm	Width of the pot rim 55 mm*
Item code	SM001	SM002	SM003	SM004	SM005	SM006

* Maximum diameter of the pot

Wall mounting brackets

	Servomix
Length	300 mm
Depth	150 mm
Height	800 mm
Weight	18 kg
Item code	SM060



Support Dynamix®
orange or black

Item code	SM030 / SM030N
-----------	-----------------------



Say stop to musculoskeletal disorders with this hook allowing enhanced manoeuvrability of your large mixers. This hook support is placed directly on the rim of the pot.

Holding hook
For the Master and SMX ranges, included in the dismantlable versions.

Item code	SM020
-----------	--------------

Website

www.dynamicmixers.com

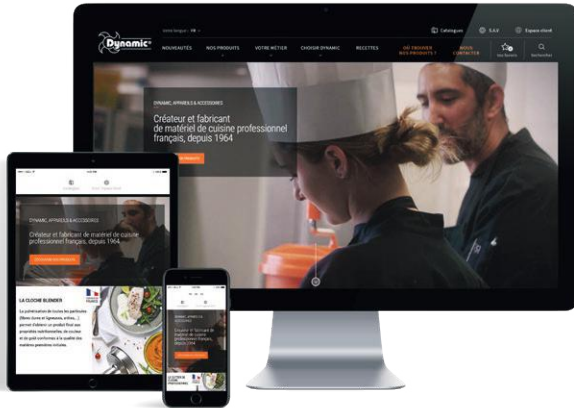

- + Photos and videos illustrating our products.
- + Download technical sheets and flyers.
- + Discover recipes with DYNAMIC equipment.
- + Contact us easily thanks to the complete contact form.

Follow us

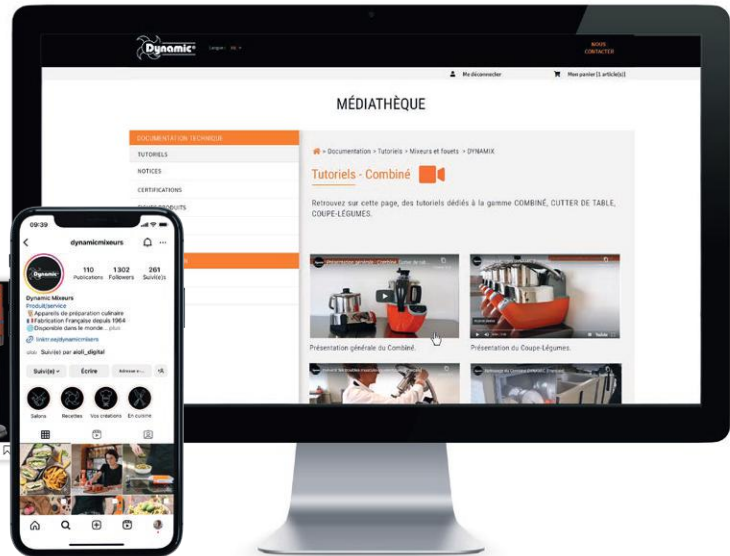

Online store & Customer service

www.sav-dynamicmixers.com

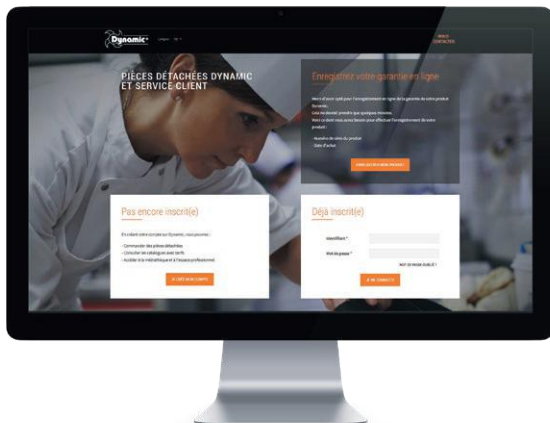

By creating your Dynamic account, you will be able to :

- + Order the totality of our range (except Turbo liquidizer and Food processor / Electrical vegetal slicers) and our spare parts.
- + Access the media library and the professional space.
- + Watch tutorials.

General sales terms and conditions (Applicable to January 1st 2024)

1 - GENERAL TERMS

In the absence of a special written agreement, all purchase orders imply the full and legal acceptance of these terms and conditions by the customer, notwithstanding any terms to the contrary that may feature in the customer's general purchase terms and conditions.

2 - ORDERS - QUOTES

Order only become final after written or tacit acceptance by DYNAMIC, hereafter referred to as "the Company". If a quote is provided, the order only becomes final after the quote is returned signed to the Company by letter, fax or any other means of transmission, within eight days of the quote being issued. Any changes to the order or the quote must be the subject of a written agreement between the Company and the customer.

3 - LEAD TIMES

Deliveries are made depending on supply and transport availability in the order in which the orders arrive, and according to the indications provided by the Company in its acceptance. The Company is authorised to make total or partial deliveries. Lead times are given for information and are not binding on the Company, especially in the event of force majeure or acts of God. No late delivery may entitle to the application of penalties or the payment of compensation, or deduction from the price or the cancellation of the order. In all cases, a customer shall only receive delivery if their situation relative to the Company is in order.

4 - DELIVERIES

Prices are given excluding VAT, FCA, packaging included. Unless there is a special indication in the order or the accepted quote, all orders are shipped with transport costs added. All the costs for express delivery are fully payable by the customer who requests this service. The goods become the property of the customer when they leave the Company shop floor, on condition of the application of the ownership clause below. Consequently all transport, customs, insurance and handling operations are at the customer's expense and at their risks and perils. The customer must make sure the delivery is compliant and check for possible damage and missing items and, where applicable, issue the necessary reserves to the relevant organisations and transporters by registered letter with acknowledgement of receipt within 72 hours. The customer shall notify the Company of this.

5- RETURNS

Any product returns must be the subject of a prior formal agreement between the Company and the customer. If accepted, 10% will be deducted for costs. Special orders cannot be returned.

6 - WARRANTY

The Company is bound to deliver goods that are compliant with the contract and shall respond to compliance faults that are found on delivery. To be compliant with the contract, the goods must:

- Be fit for the purpose expected of a similar item and, where applicable, correspond to the description given by the Company and have the properties that the Company presented to the customer in the form of a sample or model;
- Have the characteristics that a customer may legitimately expect considering the claims made by the Company, especially in advertising;
- Or have the characteristics mutually defined between the parties;

- Or be fit for any special purpose sought by the customer, made known to the Company and accepted by the Company; Electric appliances have a one year manufacturing defect warranty starting from the purchase date. The warranty covers all parts and labour. The warranty covers the replacement of any defective parts but does not cover damage from dropping or impacts, damage caused by improper use, incorrect connection to the power supply, or the failure to follow the usage conditions described in the instructions.

7 - PRICE

The prices and information featuring in the catalogues or other Company printed advertising material are only binding on the Company, which reserves the right to make any changes to the sizes, materials or weights of the products presented or described, without any duty to modify products previously delivered or of which the order is ongoing. Goods are invoiced on the basis of the price applicable at the time of the order. Payments are made to the Company headquarters. Unless special terms are agreed, orders are payable in full on shipment of the goods. A discount of 0.5% per full month, generating a proportional reduction in VAT, shall be granted on the total amount excluding VAT in the event of early payment. Any other terms of payment must be the subject of a prior agreement. On failure to pay on the contractual due date, late payment penalties equal to 3 times the legal interest rate shall be due automatically and without notice, starting from the 1st day late. Furthermore, a fixed compensation for debt recovery costs of 40 euros shall be due automatically and without notice. If the debt recovery costs are higher than this amount, additional compensation shall be due on presentation of proof. The Company may also suspend any further deliveries.

8 - OWNERSHIP

The Company retains full ownership of the sold goods until full payment by the customer. However, the risks of loss, theft or deterioration of the goods are exclusively borne by the customer as soon as the goods are made available to them. The failure to pay a term may lead to a claim for existing goods.

9 - COPYRIGHT

The drawings, models, plans and quotes, and more generally all types of document issued by the Company carry the exclusive copyright of the Company; they may not be communicated or performed without its written authorisation. They must be returned on request by the Company.

10 - RENOUNCEMENT

No late delivery, omission or any tolerance by the Company in the exercise of one of its rights resulting from this agreement shall be construed as a renouncement by the Company to the exercise of that right.

11 - JURISDICTION

In the event of a dispute, the Company and the customer in question shall undertake arbitration out of court by a single arbitrator, chosen mutually or, failing this, appointed on request from the most diligent party by the President of the Roche-sur-Yon commercial court. The parties renounce all right of appeal against the decision of the arbitrator which shall be final, and undertake to obey the decision without proceedings or exequatur.



Please contact the nearest office
for any additional information

DYNAMIC FRANCE

Société d'études et réalisations mécaniques dite DYNAMIC
518 Rue Léo Backeland, ZI du Puy Nardon
BP 57 - 85290 Mortagne-sur-Sèvre France
Tel. **+33 (0)2 51 63 02 72**
e-mail : **contact@dynamicmixers.com**

Siret : SAS - 416450435 - RCS La Roche-surYon : 416 450 435 - Capital : 216 780 €



A NEW ALTERNATIVE FOR YOUR PREPARATIONS **DYNAMIC®**
www.dynamicmixers.com

