



3 OPEN CUT MOBILE EQUIPMENT MAINTENANCE PLATFORMS



PERTH
(08) 9459 8600
KALGOORLIE
(08) 9021 8300

ADELAIDE
(08) 8231 1513
NEWMAN
(08) 9175 1164

DARWIN
(08) 8963 5621
MT ISA
(07) 4743 6458

✉ sales@bendtechgroup.com.au
🌐 bendtechgroup.com.au

2-10 Kewdale Road, Welshpool WA 6106





BEND-TECH GROUP

Bend-tech Group delivers a tailored design, engineering and fabrication service which empowers our customers towards operational safety, efficiency, and excellence. Intelligent systems and processes propel our consultative approach towards problem solving, it is imperative we create comfort and certainty. Service that takes control of problems and accountability puts solutions in motion, we have learned through a deep understanding of our customers that this is what they need.

Being global providers of designed and engineered products, services and solutions has allowed us to develop cross-industrial expertise that has galvanised our internal processes and put us at the forefront of technology and innovation. Our people are what we believe sets us apart, our culture of learning, understanding and excellence means the whole organisation progresses in synchronicity. Our team makes an impact internally, as well as throughout all our customer interactions.

Over 30 years of delivering intelligent design, custom-certified products and services has taken us across many industries and into many countries. We have provided our industry leading solutions across the Mining, Defence, Fabrication, Marine, Rail and Oil and Gas industries globally.

3 | **BUILT BETTER
BY BEND-TECH**



**OPEN CUT MOBILE EQUIPMENT
MAINTENANCE PLATFORMS****INDEX**

ABOUT BEND-TECH	/// 4
CATERPILLAR D10 - D11 DOZER	/// 6 - 7
CATERPILLAR 16M GRADER AND 24M GRADER	/// 9 - 10
CATERPILLAR 777 HAUL TRUCK	/// 12 - 15
CATERPILLAR 785D HAUL TRUCK	/// 15
CATERPILLAR 789 TRUCK	/// 16 - 17
CATERPILLAR 793F TRUCK	/// 19 - 24
CATERPILLAR 854K DROZER	/// 25
CATERPILLAR 966, 980 AND 993K WHEEL LOADER	/// 26 - 27
CATERPILLAR 994H WHEEL LOADER	/// 29 - 32
CATERPILLAR MT4400 TRUCK	/// 33
HITACHI EX3600 EXCAVATOR	/// 35
HITACHI EX5500/EX5600 PLATFORMS	/// 36 - 37
HITACHI EH5000 PLATFORMS	/// 38

**OPEN CUT MOBILE EQUIPMENT
MAINTENANCE PLATFORMS****INDEX**

EPIROC D65 PLATFORMS	///	40
KOMATSU 475A DOZER	///	42
KOMATSU 730E / 830E DUMP TRUCK	///	43 - 49
KOMATSU 930E DUMP TRUCK	///	50 - 51
KOMATSU HD1500 PLATFORMS	///	52 - 53
KOMATSU PC4000 EXCAVATOR	///	54
KOMATSU WA1200 WHEEL LOADER	///	55 - 57
LETOURNEAU L1850 WHEEL LOADER	///	59
LETOURNEAU L2350 WHEEL LOADER	///	60 - 62
LIEBHERR 996 WHEEL LOADER	///	64 - 65
LIEBHERR 9400 EXCAVATOR	///	66
VOLVO A45G / L120F WHEEL LOADER	///	67 - 68

OPEN CUT MEM PLATFORMS
ABOUT BEND-TECH



We deliver sustained value by providing cutting edge solutions through collaboration and innovation. For more than 30 years we have delivered intelligent design and customcertified products and services to the Mining, and Mobile Equipment sectors across Australia and around the world.

We have achieved this through a deep understanding of our customers and their requirements as well as innovative and industry leading design, engineering and construction. Our platforms, stands, tooling, components and lifting and handling equipment is designed to make maintenance on your mobile equipment safe, efficient and easy.

“ **MAKING MAINTENANCE
ON-SITE SAFE, EFFICIENT
AND EASY** ”



CATERPILLAR MACHINE RANGE

 www.bendtechgroup.com.au



CATERPILLAR D10 / D11 DOZER

CATERPILLAR D10/D11 REAR ACCESS PLATFORM

Part No. 5502296

Designed and engineered for the ripper and rear access of the D10 and D11 dozers. Certified and compliant with Australian Standards.

CONSTRUCTION

- Heavy-duty aluminium
- WLL: 250kg
- Self-closing gates
- Non-slip stairway and work area
- Separated into 4 sections for easy transport



CATERPILLAR D10/D11 ENGINE BAY PLATFORM

Part No. 5501737

A safe, certified and compliant access platform designed and engineered to access the engine bay on the CAT D10 and D11 Dozer for easy servicing. Does not fit D10T-2.

CONSTRUCTION

- Heavy-duty aluminium
- WLL: 250kg
- Height: 1850mm
- Non-slip stairway and work area
- Handrails fully removable
- Jacking stands
- LH and RH configurations (Sold as a set)
- Detachable handrail with swinging gate section for protection when in the engine bay

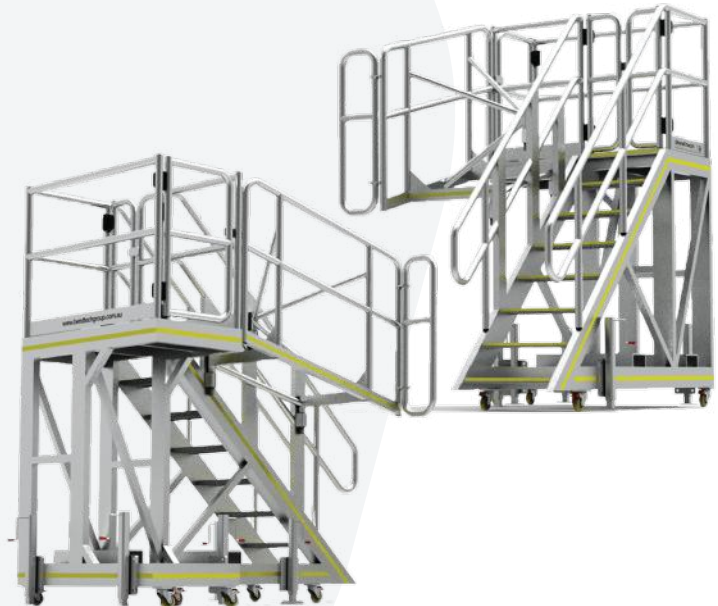

CATERPILLAR D10 / D11 DOZER

CATERPILLAR D10T2 ENGINE BAY ACCESS PLATFORM SET

Part No. 5506401

CONSTRUCTION

- Heavy-duty aluminium
- WLL: 250kg
- Fitted with jacking stands
- Detachable handrail with swinging gate section for protection when in the engine bay
- Left and right-hand configurations (Sold as a set)

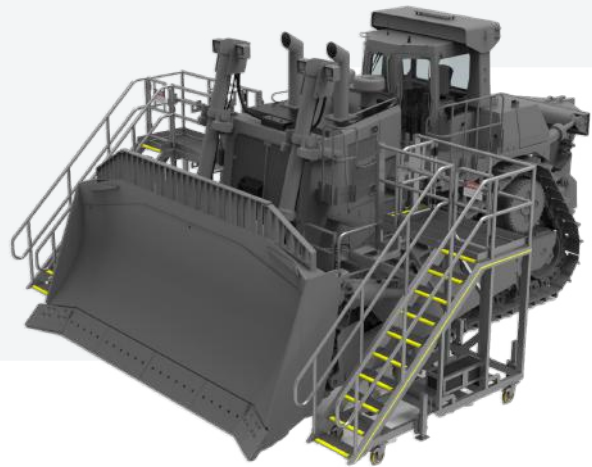

CATERPILLAR D10T SIDE ENGINE ACCESS PLATFORM

Part No. 5502808

CONSTRUCTION

- Heavy-duty aluminium
- WLL: 200kg
- Height: 1200mm
- Width: 1550mm
- Non-slip stairway and work area
- Self-closing gates
- Fitted with large industrial castors
- Interchangeable side handrails



DOZER TRACK ACCESS PLATFORM

Part No. 5505206

CONSTRUCTION

- Heavy-duty lightweight aluminium
- WLL: 250kg
- Castor wheels
- Bolt on handrails
- Swing out handrail
- Self-closing batwing gates
- Removable spigoted handrail





CATERPILLAR 16M AND 24M GRADER

CATERPILLAR 16M GRADER

CATERPILLAR 16M GRADER ACCESS PLATFORM

Part No. 5401519

CONSTRUCTION

- Heavy-duty aluminium
- WLL: 250kg
- Height: 1810mm
- Length: 1728mm
- Width: 1080mm
- Non-slip stairway and work area
- Double self-closing gate
- Safety handrails
- Wheel locks



CATERPILLAR 16M GRADER CABIN ACCESS PLATFORM

Part No. 5401590

CONSTRUCTION

- Heavy-duty aluminium
- WLL: 250kg
- Height: 1800mm
- Non-slip stairway and work area
- Jacking stands fitted on the outriggers
- Double self-closing gates
- Safety handrails
- Fork pockets for easy mobility
- Overhang and counterweight for easy access



CATERPILLAR 16M GRADER

CATERPILLAR 16M ENGINE BAY ACCESS PLATFORM

Part No. 5501593

CONSTRUCTION

- Heavy-duty aluminium
- WLL: 250kg
- Height: 1750mm
- Fitted with heavy-duty castors
- Fitted with jacking stands
- LH and RH sold as a set



CATERPILLAR 24M GRADER

CATERPILLAR 24M GRADER EMERGENCY ACCESS LADDER

Part No. 5502411

CONSTRUCTION

- Heavy-duty aluminium
- WLL: 150kg
- Gas struts for controlled release and easy lifting
- Easy-to-use latching system
- Fully TIG welded ladder construction
- Steel section finished in Y-14 safety yellow
- Non-slip nosings on ladder treads





3 | **BIGGER
THAN
BUSINESS**

CATERPILLAR 777 HAUL TRUCK

 www.bendtechgroup.com.au



CATERPILLAR 777 HAUL TRUCK

CATERPILLAR 777 CHASSIS ACCESS PLATFORM

Part No. 5502617

CONSTRUCTION

- Heavy-duty aluminium
- WLL: 300kg
- Height: 2730mm
- Non-slip stairway and work area
- Self-closing gate
- Safety handrails



CATERPILLAR 777F FRONT ACCESS PLATFORM

Part No. 5500139

CONSTRUCTION

- Heavy-duty steel
- WLL: 250kg
- Height: 2400mm
- Safety handrails
- Small Platform section at bottom and larger section at top
- This item can be customised to meet your specific needs and is engineered, certified and built to Australian Standards



CATERPILLAR 777 HAUL TRUCK

CATERPILLAR 777F WATER CART ACCESS PLATFORMS

Part No. 5501726

CONSTRUCTION

- Heavy-duty aluminium
- Height: 2450mm
- Length: 3590mm
- Width: 2800mm
- Certified and compliant with Australian Standards
- Can be customised to suit other mobile equipment
- Available in RH and LH configuration
- Non-slip walkway
- Self-closing gates



CATERPILLAR 777F WATER CART ACCESS PLATFORM

Part No. 5501050

CONSTRUCTION

- Heavy-duty aluminium
- WLL: 250kg
- Height: 2230mm
- Non-slip stairway and work area
- Self-levelling jacks
- Self-closing gate
- Safety handrails



CATERPILLAR 777 HAUL TRUCK

HAUL TRUCK AIR FILTER ACCESS PLATFORM

Part No. 5504514

CONSTRUCTION

- Heavy-duty aluminium
- WLL: 350kg
- Height: 2250mm
- Length: 1400mm
- Width: 1200mm
- Forklift slots
- Self-closing gate
- Removable handrails
- Non-slip stairway and work area
- High quality German castor wheels



CATERPILLAR 777G ENGINE BAY ACCESS

Part No. 5504690

CONSTRUCTION

- Heavy-duty aluminium
- WLL: 150kg
- Height: 1500mm
- Length: 900mm
- Width: 450mm
- Jacking Stands
- Non-slip walkway
- Removable handrails
- Fitted with forklift slots
- Supplied in LH & RH configuration
- German made castor wheels



CATERPILLAR 777 HAUL TRUCK

CATERPILLAR 777 EMERGENCY EGRESS LADDER

Part No. 5502447

CONSTRUCTION

- Various
- High strength aluminium ladder and slides
- Heavy duty steel main frame
- Torqued gear units for controlled release and easy lifting*Patent pending



CATERPILLAR 785D HAUL TRUCK

CATERPILLAR 785 CHASSIS ACCESS SYSTEM

Part No. 5505545

CONSTRUCTION

- Heavy-duty lightweight aluminium
- WLL: 250kg
- Height: 2940mm
- Swing-out gates
- Fitted with forklift slots
- Push up handrail frame
- Stairway access platform over tank
- Drop-in handrails that lock together

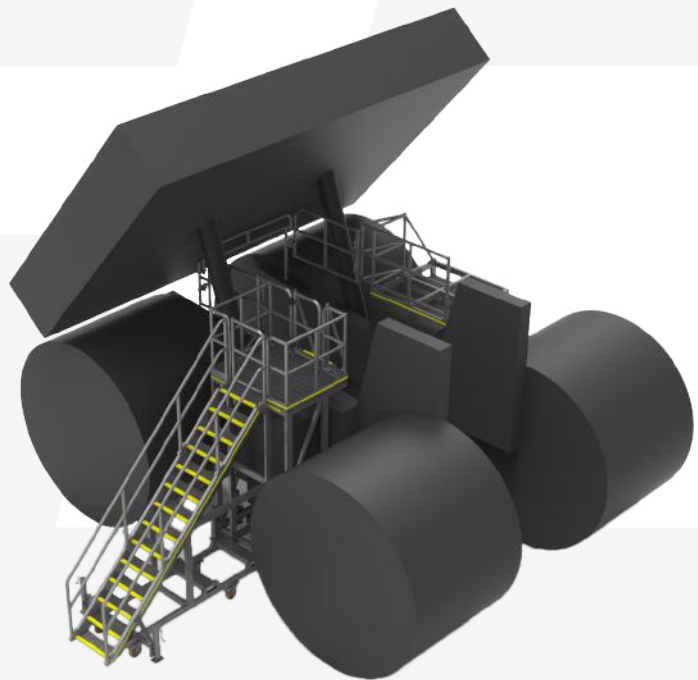

CATERPILLAR 789 HAUL TRUCK

CATERPILLAR 777-789F AIR FILTER ACCESS PLATFORM

Part No. 5501024

CONSTRUCTION

- Heavy-duty aluminium
- WLL: 250kg
- Height: 2400mm
- Non-slip stairway and work area
- Self-levelling jacks
- Self-closing gate
- Safety handrails



CATERPILLAR 789 AIR FILTER ACCESS PLATFORM

Part No. 5503385

CONSTRUCTION

- Heavy-duty aluminium
- WLL: 350kg
- Length: 2480mm
- Width: 1600mm
- Height: 3000mm
- Non-slip stairway and work area
- Self-leveling jacks
- Self-closing gate
- Removable handrails



CATERPILLAR 789 HAUL TRUCK

HAUL TRUCK AIR FILTER ACCESS PLATFORM

Part No. 5504514

CONSTRUCTION

- Heavy-duty aluminium
- WLL: 350kg
- Height: 2250mm
- Length: 1400mm
- Width: 1200mm
- Forklift slots
- Self-closing gate
- Removable handrails
- Non-slip stairway and work area
- High quality German castor wheels



CATERPILLAR 789 CHASSIS ACCESS SYSTEM

Part No. 5505251

CONSTRUCTION

- Heavy-duty lightweight aluminium
- WLL: 250kg
- Height: 3200mm
- Swing-out gates
- Fitted with forklift slots
- Push up handrail frame
- Stairway access platform over tank
- Drop-in handrails that lock together

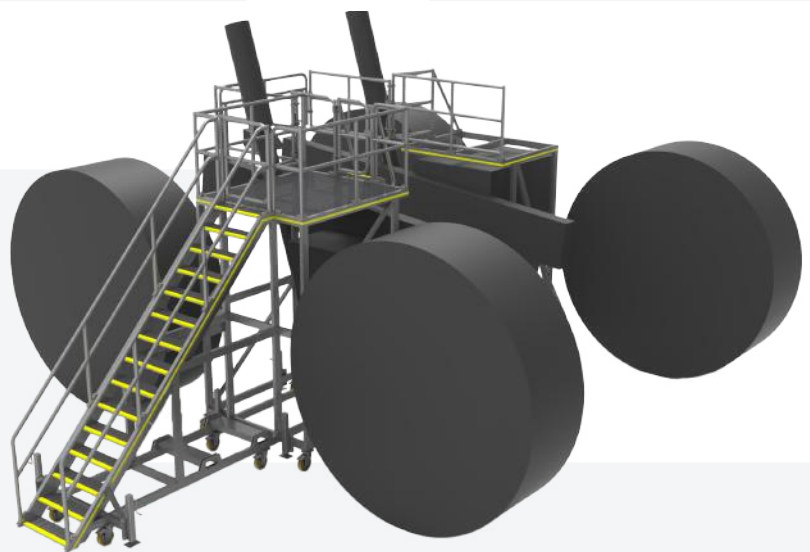



CATERPILLAR 793F TRUCK

CATERPILLAR 793F TRUCK

CATERPILLAR 793F ENGINE BAY PLATFORM

Part No. 5501493

CONSTRUCTION

- Heavy-duty aluminium
- WLL: 450kg
- Height: 1280mm
- Non-slip work area
- Jockey stands and lifting lugs
- Self closing gate
- Stability jacks
- Removable handrails and self-closing gate



IN-TRAY SIDE WALL ACCESS PLATFORM

Part No. 5503199

CONSTRUCTION

- Heavy-duty aluminium
- WLL: 250kg
- Length: 4600mm
- Width: 1900mm
- Height: 1900mm
- Heavy-duty jacking stands
- Self-closing gate
- Fitted with removable handrails



CATERPILLAR 793F STRUT AND LINE BORING PLATFORM

Part No. 5501498

CONSTRUCTION

- Heavy-duty aluminium
- WLL: 250kg
- Height: 2200mm
- Non-slip stairway and work area
- Removable handrails
- Overhang for extra access
- Easy access stairway



CATERPILLAR 793F TRUCK

MONORAIL FOR WHEEL SERVICE PLATFORM - EXTENDED REAR

Part No. 5504181

CONSTRUCTION

- Heavy-duty aluminium
- WLL: 200kg
- Length: 3200mm
- Safety handrails
- Fitted with forklift slots
- Heavy-duty caster wheels
- Certified and compliant with Australian Standard



CATERPILLAR 793F REAR STRUTS PLATFORM

Part No. 5501029

CONSTRUCTION

- Heavy-duty aluminium
- WLL: 150kg
- Height: 2100mm
- Non-slip stairway and work area
- Large industrial castors
- Self-closing gate
- Safety handrails



CATERPILLAR 793F WORK PLATFORM

Part No. 5501313

CONSTRUCTION

- Heavy-duty aluminium
- Fitted with removable handrails
- Fitted with jacking stands
- Fitted with heavy-duty castors



CATERPILLAR 793F TRUCK

CATERPILLAR 793F AIR CLEANER PLATFORM

Part No. 5501491

CONSTRUCTION

- Heavy-duty aluminium
- WLL: 250kg
- Height: 2800mm
- Non-slip stairway and work area
- Jacking stands for stability
- Mandrel bent stair safety handrails
- Overhang self-closing gate for safety and access



CATERPILLAR 793F UPPER RADIATOR ACCESS

Part No. 5415108

CONSTRUCTION

- Heavy-duty aluminium
- WLL: 250kg
- Height: 4000mm
- Non-slip stairway and work area
- Large industrial castors and levelling jacks
- Self-closing gate
- Safety handrails



CATERPILLAR 793F CHASSIS ACCESS PLATFORM RH

Part No. 5503483

CONSTRUCTION

- Heavy-duty aluminium
- WLL: 250kg
- Height: 3254mm
- Jacking legs
- Slide out handrail
- Fitted with forklift slots
- Tread nosings on all steps
- Non-slip work deck and treads
- Heavy-duty lockable castor wheels



CATERPILLAR 793F TRUCK

TRAY PIN REMOVAL PLATFORM

Part No. 5501483

CONSTRUCTION

- Heavy-duty aluminium
- WLL: 250kg
- Length: 5250mm
- Access platform for tray pin removal
- Non-slip stairway and work area
- Heavy duty castor wheels
- Safety handrails
- Stability jacks
- Multiple platform sections bolt together to form the main platform
- Self-closing gate at the top of the stairs



CATERPILLAR 793F DRIVER SIDE ACCESS PLATFORM

Part No. 5501496

CONSTRUCTION

- Heavy-duty aluminium
- WLL: 250kg
- Length: 4200mm
- Heavy duty castor wheels
- Safety handrails
- Outriggers with stability jacks
- Platform bolts together in a top and bottom section
- Self-closing gate at top of stairs and boom rail at rear



CATERPILLAR 793F CHASSIS ACCESS SYSTEM

Part No. 5507151

CONSTRUCTION

- Full TIG welded, heavy-duty aluminium RHS
- WLL: 250kg
- Fitted with forklift slots
- Non-slip stairway and work area
- Swing out fall protection gates
- Heavy-duty levelling jacking stands
- Bolt-on safety handrails with kickplates

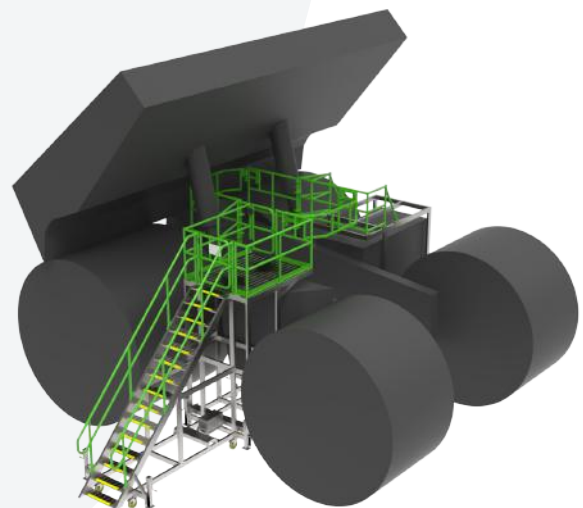

CATERPILLAR 793F TRUCK

CATERPILLAR 793F LOWER RADIATOR ACCESS PLATFORM

Part No. 5414126

CONSTRUCTION

- Heavy-duty aluminium
- WLL: 250kg
- Height: 1800mm
- Self-closing gate
- Safety handrails
- Non-slip stairway and work area
- Large industrial castors and levelling jacks



CATERPILLAR 793F LIFT ARM RAM ACCESS PLATFORM

Part No. 5504056

CONSTRUCTION

- Heavy-duty aluminium
- WLL: 250kg
- Height: 1950mm
- Non-slip stairway and work area
- Heavy-duty castor wheels
- Fitted with forklift slots
- Safety handrails



CATERPILLAR 793F TRUCK

CATERPILLAR 793F ACCESS TO CHASSIS RAIL PLATFORM

Part No. 5501028

CONSTRUCTION

- Heavy-duty aluminium
- WLL: 250kg
- Height: 1700mm
- Non-slip stairway and work area
- Large industrial castors and levelling jacks
- Self-closing gate
- Safety handrails



CATERPILLAR 793F REAR TRAY ACCESS PLATFORM

Part No. 5503517

CONSTRUCTION

- Heavy-duty aluminium
- Height: 5200mm
- Self closing gate
- Jack stands
- Stair access
- Wing out handrails
- Fitted with forklift pockets
- German made castor wheels

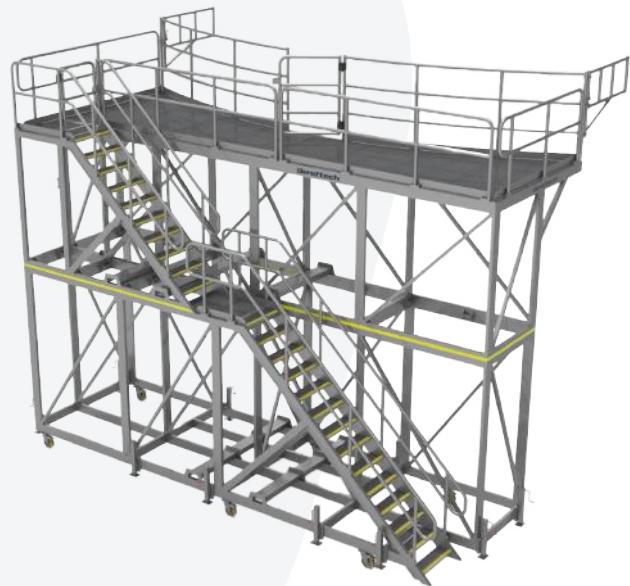

CATERPILLAR 854K DROZER

CATERPILLAR 854K EMERGENCY LADDER

Part No. 5502306

CONSTRUCTION

- Heavy-duty aluminium
- ladder and slides
- Heavy-duty steel
- main frame
- WLL: 150kg
- Height: 2800mm
- Non-slip ladder nosings
- Torqued gear units for controlled release and easy lifting



CATERPILLAR 854K LIFT CYLINDER ACCESS PLATFORM

Part No. 5504712

CONSTRUCTION

- Heavy-duty aluminium
- WLL: 150kg
- Height: 2250mm
- Fitted with forklift slots
- German made castor wheels
- Non-slip grating and stair treads
- Platform splits in 2 and clips together

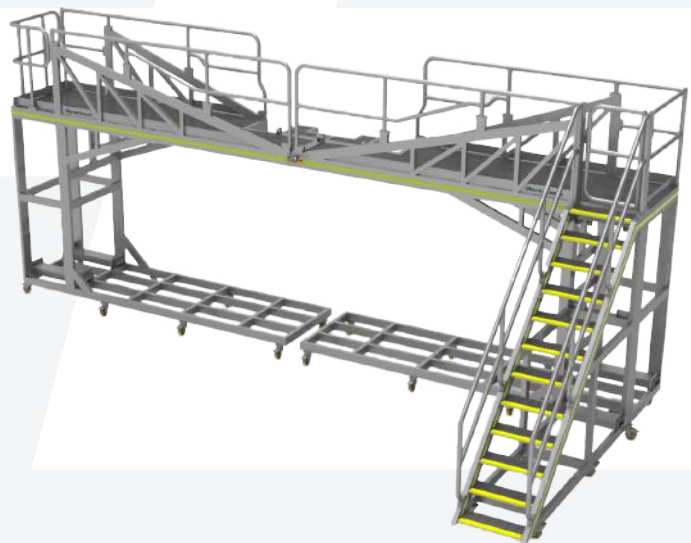

CATERPILLAR 966 WHEEL LOADER

CATERPILLAR 966 ELECTRICAL ACCESS PLATFORM

Part No. 5501444

CONSTRUCTION

- Heavy-duty aluminium
- Non-slip stairway and work area
- Small access platform
- Safety rails
- Fixed wheels at rear
- Self-closing gates



CATERPILLAR 980 WHEEL LOADER

CATERPILLAR 980M SAFETY ACCESS PLATFORM SET

Part No. 5501049

CONSTRUCTION

- Heavy-duty aluminium
- WLL: 250kg
- Height: 1120mm
- Non-slip stairway and work area
- Self-closing gate
- Safety handrails



CATERPILLAR 993K WHEEL LOADER

CATERPILLAR 993K LOWER RH ARTIC ACCESS PLATFORM

Part No. 5503773

CONSTRUCTION

- Heavy-duty aluminium
- WLL: 150kg
- Height: 1200mm
- Non-slip stairway and work area
- Safety handrails and self-closing gate





CATERPILLAR 994H WHEEL LOADER



CATERPILLAR 994H WHEEL LOADER

CATERPILLAR 994H ACCESS PLATFORM

Part No. 5501487

CONSTRUCTION

- Heavy-duty aluminium
- WLL: 250kg
- Length: 2850mm
- LH and RH side work platforms with additional middle platform
- Safety handrails
- Self closing gate
- Provides safe and efficient access

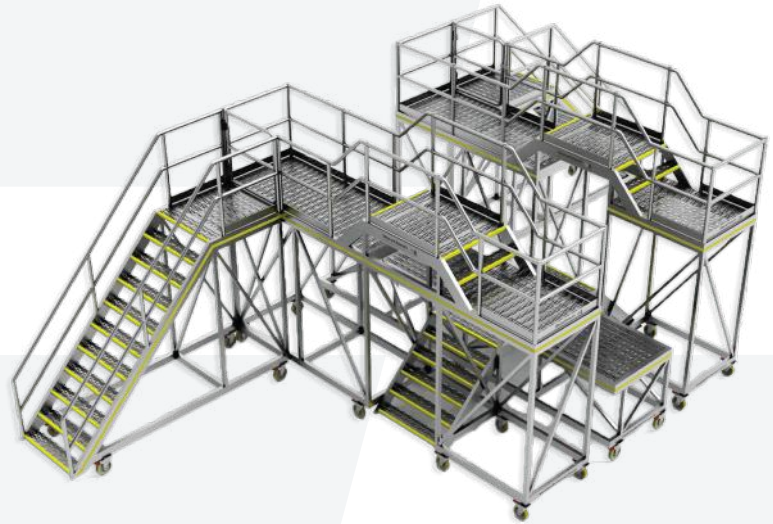

CATERPILLAR 994H ARCTIC PLATFORM

Part No. 5501865

CONSTRUCTION

- Heavy-duty aluminium
- WLL: 250kg
- Height: 2850mm
- Non-slip stairway and work area
- Adjustable handrails at front
- Self closing gate
- Extended overhang for extra access



CATERPILLAR 994H WHEEL LOADER

CATERPILLAR 994H ARTIC HIGH ACCESS PLATFORM

Part No. 5501486

CONSTRUCTION

- Heavy-duty aluminium
- WLL: 250kg
- Length: 2840mm
- Non-slip stairway and work area
- Self-closing gate
- Safety handrails
- Boom rail on front
- Outriggers with levelling jacks
- Fork pockets for easy transport



CATERPILLAR 994H FRONT ARMS AND PIN PLATFORM

Part No. 5501499

CONSTRUCTION

- Heavy-duty aluminium
- WLL: 250kg
- Length: 3350mm
- Non-slip stairway and work area
- Removable handrails for easy of access
- Self closing gate
- Platforms bolt together for transport

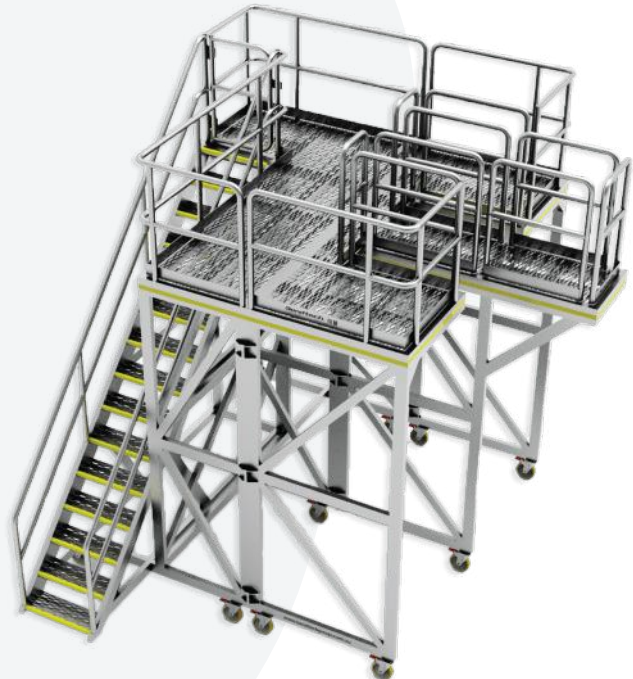

CATERPILLAR 994H WHEEL LOADER

CATERPILLAR 994H EMERGENCY SIDE ACCESS AND WORK PLATFORM

Part No. 5501862

CONSTRUCTION

- Heavy-duty aluminium
- WLL: 400kg
- Height: 2100mm
- Non-slip stairway and work area Self-closing gate
- Safety handrails



CAT 994H LH - RH ARTIC SHORT PLATFORM

Part No. 5501492

CONSTRUCTION

- Heavy-duty aluminium
- WLL: 250kg
- Height: 900mm
- Non-slip stairway and work area
- Safety handrails
- Self-closing gate
- Jacking stands for stability



CATERPILLAR 994H WHEEL LOADER

CATERPILLAR 994H FRONT TILT ACCESS PLATFORM

Part No. 5501919

CONSTRUCTION

- Heavy-duty steel
- Non-slip work area
- Steel plates weld to bucket
- Platform bolts onto welded plates
- Safety handrails painted Y14 safety yellow



CAT 994 EMERGENCY EGRESS LADDER

Part No. 5504157

CONSTRUCTION

- High strength aluminium ladder
- High strength aluminium slides
- Non-slip ladder nosing's
- Heavy duty steel main frame
- Torqued gear units for controlled release and easy lifting
- Certified and compliant with Australian Standards *Patent pending



CATERPILLAR MT4400 TRUCK



A safe, certified and compliant access platform designed and engineered to access the front of the CAT MT4400 dump truck

CONSTRUCTION

- Heavy-duty aluminium
- WLL: 250kg
- Height: 2180mm
- Non-slip stairway and work area
- Large overhang for access
- Safety handrail
- Self-closing gate at the top of the stairs
- Certified and compliant with Australian Standards



CAT MT4400 FRONT ACCESS PLATFORM

Part No. 5501497



HITACHI MACHINE RANGE

HITACHI EX3600 EXCAVATOR

HITACHI EX3600 ALUMINIUM LADDER EXTENSION

Part No. 5502538

CONSTRUCTION

- Heavy-duty lightweight aluminium
- WLL: 150kg
- Easy attachment to bottom of the OEM ladder

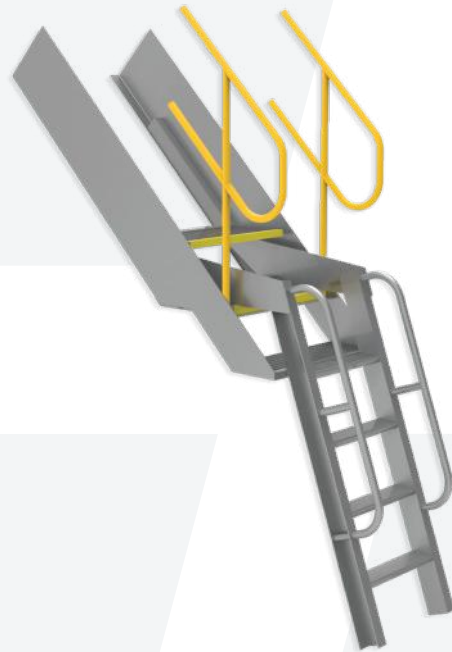

HITACHI EX3600 BUCKET REPAIR PLATFORM

Part No. 5501885

A platform designed for the safe, certified and compliant access and repair of the EX5600 bucket.

CONSTRUCTION

- Heavy-duty steel
- Can be used in the pit if needed
- Galvanised grid mesh
- Safety handrails
- painted in Y14 safety yellow



HITACHI EX5500/ EX5600

HITACHI EX5500/EX5600 SLEW BEARING PLATFORM CHANGEOUT KIT

Part No. 5501259

A platform designed to access the front and back area of the slew bearing between the track. Safe, certified and compliant maintenance on both the EX5500 and EX5600.

CONSTRUCTION

- Heavy-duty aluminium
- WLL: 250kg
- Height: 2300mm
- Complete with handrails
- Handrails gaps are half meshed for increased safety
- Handrails bolt on the fixed threaded blocks
- Removable handrails
- Removable platforms at front of platform



HITACHI EX5500/EX5600 ACCESS PLATFORM

Part No. 5501245

CONSTRUCTION

- Heavy-duty steel
- WLL: 250kg
- Height 2060mm
- Fitted with handrails that hook over tracks
- Platform sits at front of machine and handrails on edge of tracks



HITACHI EX5500/ EX5600

HITACHI EX5600 ACCESS PLATFORM

Part No. 5501451

CONSTRUCTION

- Heavy-duty steel
- WLL: 250kg
- Height: 1800mm
- Wheels for ease of mobility
- Non-slip stairway and work area
- Fitted with Self-closing gate and safety handrails



HITACHI EX5600 BOOM ARCH HOSE ACCESS PLATFORM

Part No. 5504765

CONSTRUCTION

- Heavy-duty aluminium/steel
- WLL: 250kg
- Length: 2925mm
- Width: 1270mm
- Safety handrails on sides
- Eliminates the need for scaffold
- Interchangeable lightweight aluminium access planks



HITACHI EH5000

HITACHI EH5000 ENGINE BAY ACCESS PLATFORM

Part No. 5504488

CONSTRUCTION

- Heavy-duty aluminium
- WLL: 150kg
- Length: 960mm
- Width: 500mm
- Height: 2700mm
- Self-closing gate
- Safety handrails
- Fitted with forklift slots
- Large industrial castors
- Non-slip stairway and work area



HITACHI EH5000 CHASSIS ACCESS SYSTEM

Part No. 5504563

CONSTRUCTION

- Heavy-duty aluminium
- WLL: 250kg
- Height: 3900mm
- Swing-out gates
- Fitted with forklift slots
- Push up handrail frame
- Stairway access platform over tank
- Drop-in handrails that lock together





3 **BIGGER
THAN
BUSINESS**



EPIROC MACHINE RANGE

 www.bendtechgroup.com.au



**EPIROC
D65**

**EPIROC D65 SIDE
ACCESS PLATFORMS**

Part No. 5504703

CONSTRUCTION

- Heavy-duty aluminium
- WLL: 250kg per platform
- Jacking stands
- Self-closing gate
- Removable handrails
- Fitted with forklift slots
- German made castor wheels

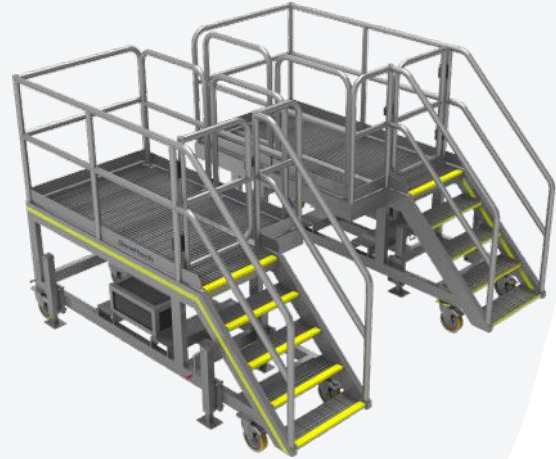

**EPIROC D65 SIDE
ACCESS PLATFORM**

Part No. 5507197

CONSTRUCTION

- Heavy-duty aluminium
- WLL: 250kg
- Height: 1025mm
- Self-closing gate
- Fitted with forklift slots
- High quality castor wheels



**EPIROC D65 MAST
ACCESS PLATFORM**

Part No. 5506717

CONSTRUCTION

- Heavy-duty aluminium
- WLL: 250kg
- Height: 1800mm
- Self closing gate
- Fitted with forklift slots
- High quality castor wheels
- Bolt-on handrails with kickplates
- Non-slip nosings on all stair treads





3 | **BIGGER
THAN
BUSINESS**

730E

KOMATSU MACHINE RANGE

 www.bendtechgroup.com.au



KOMATSU
475A DOZER



A safe, certified and compliant access platform designed and engineered to suit accessing the engine bay of both the CAT D11 dozer and KOMATSU 475A

CONSTRUCTION

- Heavy-duty
- WLL: 250kg
- Height: 1810mm
- Large non-slip stairway and platform deck for stability and space
- Swing out gates on end of platform can be locked in place incrementally
- Self-closing gate at the top of the stairs
- Safety handrail
- Large 300mm all terrain rubber wheels
- Fitted jacking stands



KOMATSU 475A DOZER
ENGINE BAY ACCESS PLATFORM

Part No. 5501431

KOMATSU 730E/830E DUMP TRUCK

HAUL TRUCK WHEEL SERVICE PLATFORM

Part No. 5401579

CONSTRUCTION

- Heavy-duty aluminium
- Non-slip stairway and work area
- Removable handrails
- Self closing gate
- Work bench on both ends for tool storage
- Adjustable jacking stands for uneven ground
- Monorail available as a manual handling upgrade
- Also suitable for the KOMASTU 830E



FRONT CALIPER REMOVAL MONORAIL PLATFORM

Part No. 5503423

CONSTRUCTION

- Heavy-duty aluminium
- Non-slip stairway and work area
- Removable handrails
- Self closing gate
- Work bench on both ends for tool storage
- Adjustable jacking stands for uneven ground
- Monorail available as a manual handling upgrade
- Also suitable for the KOMASTU 830E



KOMATSU 730E/830E FRONT ENGINE ACCESS PLATFORM

Part No. 5502481

CONSTRUCTION

- Heavy-duty aluminium
- Non-slip stairway and work area
- Fitted with heavy-duty lockable castors
- Fitted with work bench
- Also suitable for the KOMASTU 830E



KOMATSU 730E/830E DUMP TRUCK

KOMATSU 730E/830E OVER FUEL TANK ACCESS PLATFORM

Part No. 5501514

CONSTRUCTION

- Heavy-duty aluminium
- WLL: 350kg
- Height: 3800mm
- Non-slip stairway and work area
- Out-swinging gates and safety handrails
- Also suitable for the KOMASTU 830E



KOMATSU 730E/830E BATTERY MAINTENANCE PLATFORM

Part No. 5502477

CONSTRUCTION

- Heavy-duty aluminium
- WLL: 150kg
- Height: 800mm
- Non-slip stairway and work area
- Fitted with heavy-duty lockable castors
- Also suitable for the KOMASTU 830E



KOMATSU 730E/830E FRONT ENTRY ACCESS PLATFORM STAIRS

Part No. 5501721

CONSTRUCTION

- Heavy-duty aluminium
- WLL: 150kg
- Height: 800mm
- Dual self-closing gates at the rear of the platform
- Non-slip stairway and work area
- Also suitable for the KOMASTU 830E and 930E



KOMATSU 730E/830E DUMP TRUCK

KOMATSU 730E ENGINE BAY PLATFORM

Part No. 5501231

CONSTRUCTION

- Heavy-duty steel
- Supplied in pairs
- Extended height handrails
- Complete safety when working in hard to reach areas



KOMATSU 730E/830E ENGINE ACCESS PLATFORM

Part No. 5502934

CONSTRUCTION

- Heavy-duty aluminium
- WLL: 200kg
- Height: 1900mm
- Non-slip stairway and work area
- Safety handrails
- High quality caster wheels
- Also suitable for the KOMASTU 830E



HAUL TRUCK AIR FILTER ACCESS PLATFORM

Part No. 5504514

CONSTRUCTION

- Heavy-duty aluminium
- WLL: 350kg
- Height: 2250mm
- Length: 1400mm
- Width: 1200mm
- Forklift slots
- Self-closing gate
- Removable handrails
- Non-slip stairway and work area
- High quality German castor wheels



KOMATSU 730E/830E DUMP TRUCK

KOMATSU 730E TRAY PIN ACCESS PLATFORM

Part No. 5504721

CONSTRUCTION

- Heavy-duty aluminium
- WLL: 150kg
- Height: 2155mm
- Length: 1315mm
- Width: 950mm
- Fitted with forklift slots
- Non-slip stairway and work area
- Heavy-duty lockable castor wheels



KOMATSU 730E LIFT CYLINDER PIN ACCESS PLATFORMS

Part No. 5504720

CONSTRUCTION

- Heavy-duty aluminium
- WLL: 150kg
- Height: 1650mm, 1850mm
- Length: 1115mm, 900mm
- Width: 750mm
- Fitted with forklift slots
- Non-slip stairway and work area
- Heavy-duty lockable castor wheels

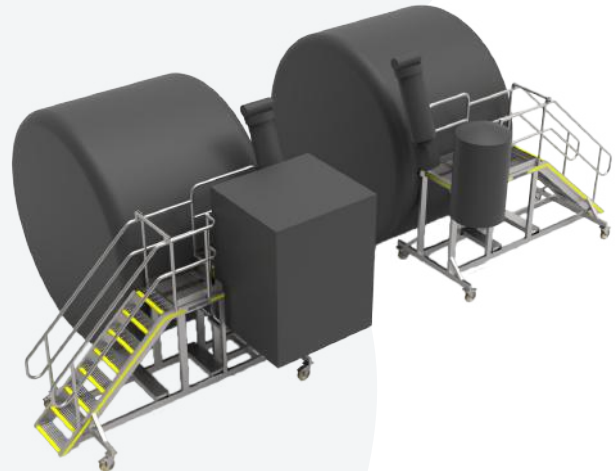

KOMATSU 730E/830E ENGINE BAY ACCESS PLATFORM AND LADDER

Part No. 5001793

CONSTRUCTION

- Heavy-duty aluminium
- Height: 1181mm
- Length: 1975mm
- Width: 485mm
- Fold-down ladder
- Sliding access door
- Extended height handrails
- Complete safety when working in hard to reach areas



KOMATSU 730E/830E DUMP TRUCK

KOMATSU 830E ACI ENGINE MODULES PLATFORM

Part No. 5501247

CONSTRUCTION

- Heavy-duty aluminium
- WLL: 200kg
- Height: 750mm
- Access for both sides of engine
- Non-slip stairway and work area
- Safety handrails
- Self closing gates



KOMATSU 830E STRUT ACCESS PLATFORM

Part No. 5502975

CONSTRUCTION

- Heavy-duty aluminium
- WLL: 150kg
- Height: 2200mm
- Non-slip stairway and work area
- Fitted with heavy-duty lockable castors



KOMATSU 830E TRAY ACCESS PLATFORM

Part No. 5504575

CONSTRUCTION

- Heavy-duty aluminium
- WLL: 150kg
- Height: 5500mm
- Fitted with swinging side handrails
- Heavy-duty castor wheels
- Jacking stands
- Certified and compliant with Australian Standards

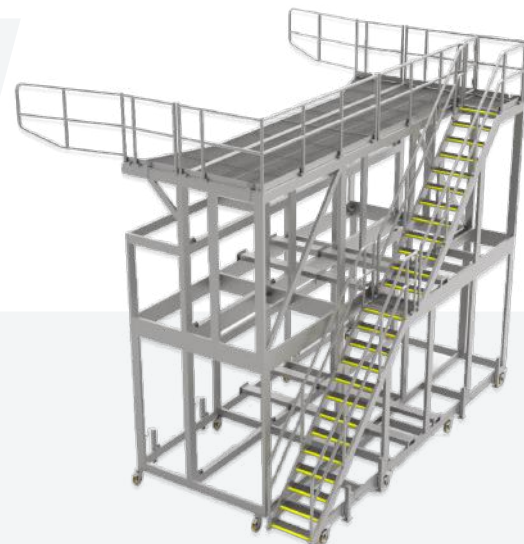

KOMATSU 730E/830E DUMP TRUCK

KOMATSU 830E FIRE SUPPRESSION PLATFORM

Part No. 5504708

CONSTRUCTION

- Heavy-duty aluminium
- WLL: 400kg
- Height: 1650mm
- Length: 2800mm
- Width: 1800mm
- Self-closing gate
- Toolbox for storage
- Fitted with forklift slots
- German made castor wheels



KOMATSU 830E PLATFORM WITH LADDER RHS

Part No. 5002104

CONSTRUCTION

- Heavy-duty aluminium
- SWL: 150kg
- Height: 580mm
- Locking gates for safety
- Can be modified for tyre and truck configurations



KOMATSU 830E REAR STRUTS AND ACCUMULATOR PLATFORM

Part No. 5501201

CONSTRUCTION

- Heavy-duty aluminium
- WLL: 150kg
- Height: 2100mm
- Length: 1250mm
- Width: 600mm
- Forklift slots
- Safety handrails
- Self-closing gate
- Fitted with heavy-duty lockable castors



KOMATSU 730E/830E DUMP TRUCK

KOMATSU 830E MONORAIL FOR WHEEL SERVICE PLATFORM - EXTENDED REAR

Part No. 5504181

CONSTRUCTION

- Heavy-duty aluminium
- WLL: 200kg
- Length: 3200mm
- Safety handrails
- Fitted with forklift slots
- Heavy-duty caster wheels
- Certified and compliant with Australian Standard



KOMATSU 830E AIR CONDITIONER ACCESS PLATFORM

Part No. 5507068

CONSTRUCTION

- Heavy-duty aluminium
- WLL: 150kg
- Height: 2080mm
- Length: 1800mm
- Width: 1200mm
- Non-slip nosings on all stair treads
- Bolt-on safety handrails with kickplates
- Non-slip serrated grating work deck and stair treads



KOMATSU 930E DUMP TRUCK

KOMATSU 930E FRONT ENTRY ACCESS PLATFORM STAIRS

Part No. 5501721

CONSTRUCTION

- Heavy-duty aluminium
- WLL: 150kg
- Height: 800mm
- Dual self-closing gates at the rear of the platform
- Non-slip stairway and work area
- Also suitable for the KOMASTU 830E and 930E



KOMATSU 930E REAR TRAY PLATFORM

Part No. 5504707

CONSTRUCTION

- Heavy-duty aluminium
- WLL: 500kg
- Height: 5850mm
- Jacking stands
- Self-closing gates
- Swing-out handrails
- Fitted with forklift slots

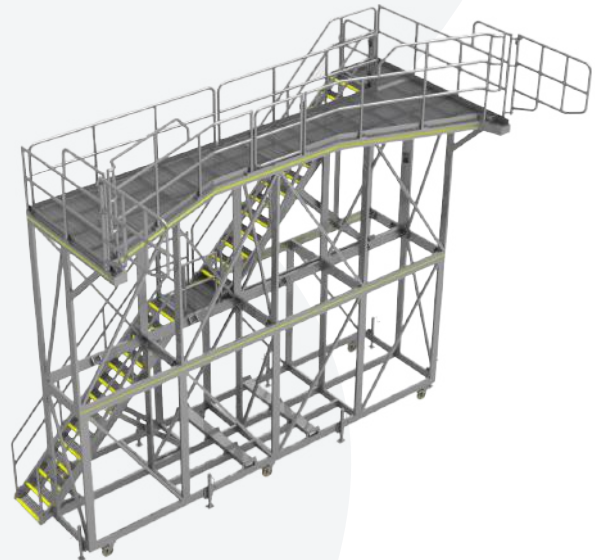

KOMATSU 930E BATTERY ACCESS PLATFORM

Part No. 5506004

CONSTRUCTION

- Heavy-duty lightweight aluminium
- WLL: 250kg
- Height: 1100mm
- Length: 2800mm
- Width: 1950mm
- Jacking stands
- Self-closing gates
- Double height handrails
- Fitted with forklift slots



KOMATSU 930E DUMP TRUCK

KOMATSU 930E STRUT ACCESS PLATFORM

Part No. 5501773

CONSTRUCTION

- Heavy-duty aluminium
- Height: 2300mm
- Length: 2300mm
- Width: 1200mm
- Self closing gate
- Outriggers for extra stability
- Non-slip stairway and work area
- Removable handrails on front for easy access



KOMATSU 930E STRUT PIN ACCESS PLATFORM

Part No. 5503428

CONSTRUCTION

- Heavy-duty aluminium
- WLL: 150kg
- Height: 1470mm
- Length: 1200mm
- Width: 2350mm
- Self-closing gate
- Levelling jacking stands
- Non-slip stairway and work area
- Removable handrails on front for easy access



KOMATSU 930E ENGINE ACCESS PLATFORM

Part No. 5503559

CONSTRUCTION

- Heavy-duty aluminium
- WLL: 200kg
- Height: 1200mm
- Length: 1000mm
- Width: 550mm
- Safety handrails
- Non-slip stairway and work area
- Fitted with forklift slots for ease of transport



KOMATSU HD1500

KOMATSU HD1500 TRAY PIN ACCESS PLATFORM

Part No. 5504739

CONSTRUCTION

- Heavy-duty aluminium
- WLL: 150kg
- Height: 1900mm
- Length: 1340mm
- Width: 850mm
- Self-closing gates
- Non-slip stair nosings
- Fitted with forklift slots



KOMATSU HD1500 CHASSIS ACCESS PLATFORM

Part No. 5504737

CONSTRUCTION

- Heavy-duty aluminium
- WLL: 250kg
- Height: 3000mm
- Length: 1900mm
- Width: 1500mm
- Push up handrail frame
- Fitted with forklift slots
- Stairway access platform over tank
- Drop-in handrails that lock together

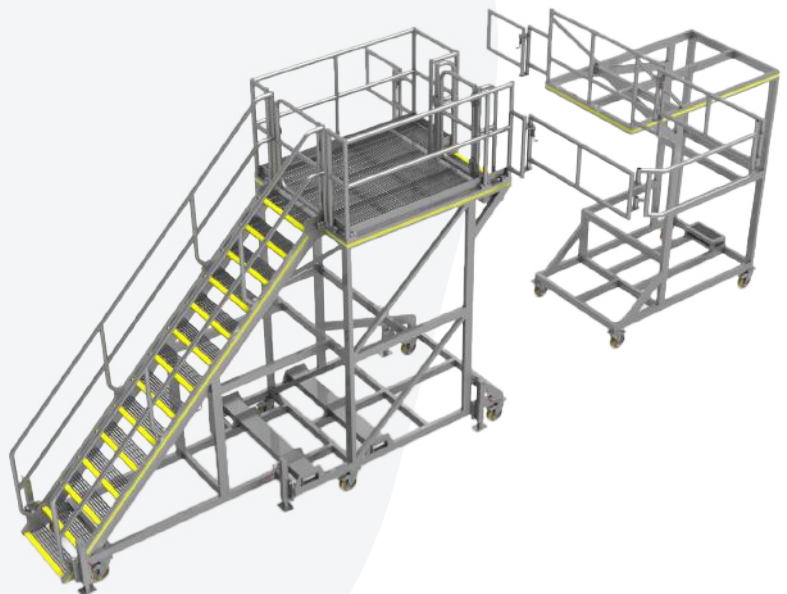

KOMATSU HD1500

KOMATSU HD1500 ENGINE BAY ACCESS PLATFORM

Part No. 5504753

CONSTRUCTION

- Heavy-duty aluminium
- Height: 1500mm
- Length: 1800mm
- Width: 450mm
- Permanent kickplates
- Removable safety handrails
- Non-slip nosings on all stair treads
- Interchangeable between LH and RH sides



KOMATSU HD1500-8 REAR ACCESS PLATFORM

Part No. 5505209

CONSTRUCTION

- Heavy-duty steel
- Height: 1202mm
- Length: 1932mm
- Width: 948mm
- Folding handrail for when not in use



KOMATSU PC4000 EXCAVATOR

KOMATSU WA1200 TREADLE ACCESS PLATFORM SET

Part No. 5502821

CONSTRUCTION

- Heavy-duty aluminium
- WLL: 350kg
- Height: 2850mm
- Self-closing gate
- Fitted with forklift slots
- Bolt-on safety handrails
- Non-slip stairway and work area
- Large industrial castors and leveling jack



PUMP ROOM UNDERSIDE ACCESS PLATFORM

Part No. 5502859

CONSTRUCTION

- Heavy-duty steel and aluminium
- WLL: 200kg
- Self-closing gate
- Safety handrails
- 8' x 5' trailer
- Non-slip stairway and work area
- Oil drain bund inside trailer with evac point



KOMATSU PC4000 AND HITACHI EX5500 PUMP ROOM ACCESS PLATFORM

Part No. 5502822

CONSTRUCTION

- Heavy-duty aluminium
- WLL: 400kg
- Height: 4100mm
- Self-closing gate
- Safety handrails
- Non-slip stairway and work area
- Large industrial castors and leveling jacks



KOMATSU WA1200 WHEEL LOADER

KOMATSU WA1200 ARTIC FRONT STRUT AREA PLATFORM

Part No. 5501638

CONSTRUCTION

- Heavy-duty aluminium
- WLL: 250kg
- Height: 1900mm
- LH and RH configurations
- Non-slip stairway and work area
- Removable handrails on all sides for easy access
- Self-closing gate



KOMATSU WA1200 FRONT ARTIC / BOOM HOSE ACCESS

Part No. 5501039



CONSTRUCTION

- Heavy-duty aluminium
- Large industrial castors
- Non-slip stairway and work area
- Self-closing gates
- Safety handrails

KOMATSU WA1200 FRONT HATCH ACCESS PLATFORM

Part No. 5501582



CONSTRUCTION

- Heavy-duty aluminium
- WLL: 250kg
- Height: 3000mm
- Non-slip stairway and work area
- Self-closing doors
- Flip down handrails

KOMATSU WA1200 WHEEL LOADER

KOMATSU WA1200 TREADLE ACCESS PLATFORM SET Part No. 5502820

CONSTRUCTION

- Heavy-duty aluminium
- Height: 2260mm
- Non-slip stairway and work area
- LH and RH configurations
- Removable handrails on all sides for ease of access
- Self-closing gates



KOMATSU WA1200 INTERNAL TRANSMISSION AREA ACCESS PLATFORM Part No. 5501628



CONSTRUCTION

- Heavy-duty aluminium
- Recessed lifting lugs in platform deck for crane access
- Narrow access
- For slots for efficient mobility

WA1200 BUCKET WORK PLATFORM Part No. 5502307



CONSTRUCTION

- Heavy-duty aluminium
- WLL: 500kg
- Large industrial castors
- Non-slip stairway and work area
- Self-closing gates

KOMATSU WA1200 WHEEL LOADER

KOMATSU WA1200 DROP-IN BUCKET PIN ACCESS PLATFORM

Part No. 5502744

CONSTRUCTION

- Heavy-duty steel
- WLL: 250kg
- Fitted with self-closing gates
- Designed and engineered to safely access the bucket pins at the front of the Komatsu WA1200 Loader



KOMATSU WA1200 ACCESS AND PROTECTION

Part No. 5501654



CONSTRUCTION

- Heavy-duty aluminium
- Weld on steel base plates
- Handrails thread on to steel blocks welded to WA1200
- Handrails finished in Y14 safety yellow

KOMATSU WA1200 TRANSMISSION COVER

Part No. 5504710



CONSTRUCTION

- Heavy-duty aluminium
- WLL: 400kg
- Removable handrails
- Non-slip grating deck and edges
- Handrails finished in Y14 safety yellow



LETOURNEAU MACHINE RANGE

LETOURNEAU L1850 WHEEL LOADER

LETOURNEAU L1850 LOWER ARTIC ACCESS PLATFORM

Part No. 5504617

CONSTRUCTION

- Heavy-duty aluminium
- WLL: 250kg
- Height: 1150mm
- Heavy-duty caster wheels
- Heavy-duty jacking stands
- Drop bar gate
- Fitted with forklift slots



LETOURNEAU L1850 RH SIDE ENGINE ACCESS PLATFORM

Part No. 5504616

CONSTRUCTION

- Heavy-duty aluminium
- WLL: 250kg
- Height: 1400mm
- Heavy-duty caster wheels
- Heavy-duty jacking stands
- Drop bar gate
- Fitted with forklift slots



LETOURNEAU L1850 HV CABINET ACCESS PLATFORM

Part No. 5504580

CONSTRUCTION

- Heavy-duty steel
- WLL: 250kg
- Height: 1400mm
- Heavy-duty caster wheels
- Heavy-duty jacking stands
- Drop bar gate
- Fitted with forklift slots



LETOURNEAU L2350 WHEEL LOADER

LETOURNEAU L2350 SIDE ACCESS PLATFORM

Part No. 5501574L + 5501574R

CONSTRUCTION

- Heavy-duty aluminium
- WLL: 250kg
- Height: 4350mm
- LH and RH configuration
- Non-slip stairway and work area
- Levelling jacks for uneven ground
- Self closing gate at top of stairs
- Removable handrails

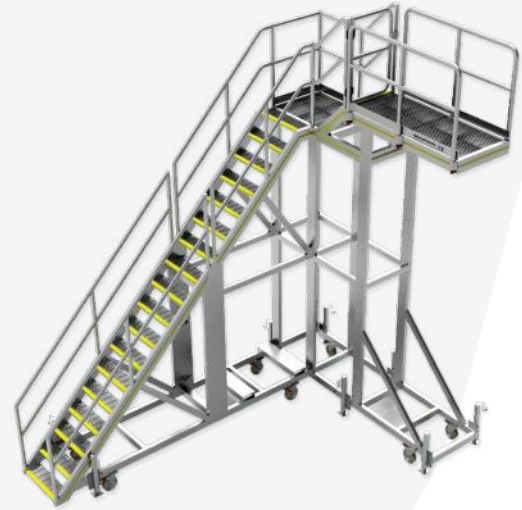

LETOURNEAU L2350 ARTIC AREA ACCESS PLATFORM

Part No. 5501580

CONSTRUCTION

- Heavy-duty aluminium
- WLL: 250kg
- Height: 3100mm
- Heavy duty castor wheels
- Outriggers with stability jacks
- Platform bolts together in a top and bottom section
- Self-closing gate at top of stairs and boom rail at rear



LETOURNEAU L2350 AIRCON CONDENSOR ACCESS PLATFORM

Part No. 5501891

CONSTRUCTION

- Heavy-duty steel
- Rubber on base plates for stability when on deck
- Self-closing doors
- Safety handrails



LETOURNEAU L2350 WHEEL LOADER

LETOURNEAU L2350 FRONT PIN BASE

Part No. 5501736

CONSTRUCTION

- Heavy-duty aluminium
- Fixed on the front section
- Handrails for safe access
- Certified and compliant with Australian Standards



LETOURNEAU L2350 LH - RH STRUT REMOVAL PLATFORM

Part No. 5501735

CONSTRUCTION

- Heavy-duty aluminium
- Suits left and right hand configurations
- Stability jacks
- Removable handrails and Removable step
- Double self-closing doors



LETOURNEAU L2350 REAR RADIATOR ACCESS PLATFORM

Part No. 5503563

CONSTRUCTION

- Heavy-duty aluminium
- WLL: 350kg
- Forklift slots
- Self-closing gate
- Removable handrails
- Non-slip nosings on all stair treads
- Bolt-on safety handrails with kickplates



LETOURNEAU L2350 WHEEL LOADER

LETOURNEAU L2350 ARTIC SHORT ACCESS PLATFORM SET

Part No. 5502214

CONSTRUCTION

- Heavy-duty aluminium
- WLL: 150kg
- Height: 1785mm
- Non-slip stairway and work area
- Levelling jacks for uneven ground
- Self-closing gate at top of stairs
- Removable handrails





3 | **BIGGER
THAN
BUSINESS**



LIEBHERR MACHINE RANGE

 www.bendtechgroup.com.au



LIEBHERR 996 WHEEL LOADER

LIEBHERR 996 SLEW BEARING CHANGEOUT KIT

Part No. 5501448

CONSTRUCTION

- Heavy-duty steel
- Certified and compliant with Australian Standards
- Hot-dip galvanised

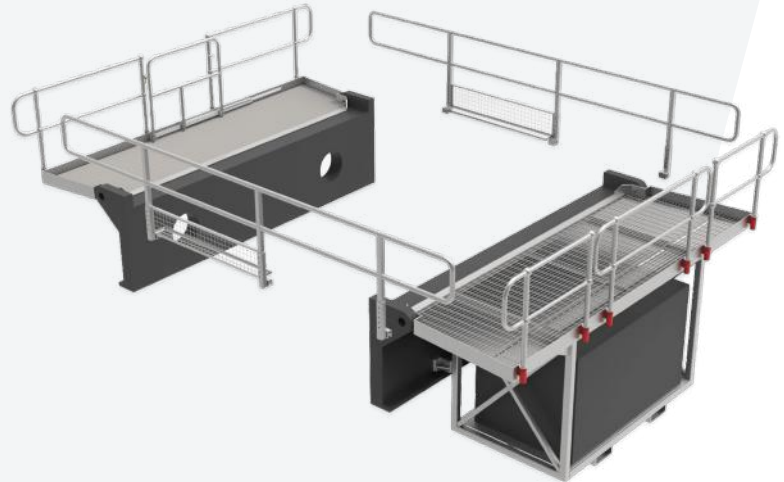

LIEBHERR 996 TRACK MOUNT ACCESS PLATFORM

Part No. 5501409

CONSTRUCTION

- Heavy-duty aluminium
- Fitted with self-closing gates
- Fitted with toolbox
- Fitted with rigging storage

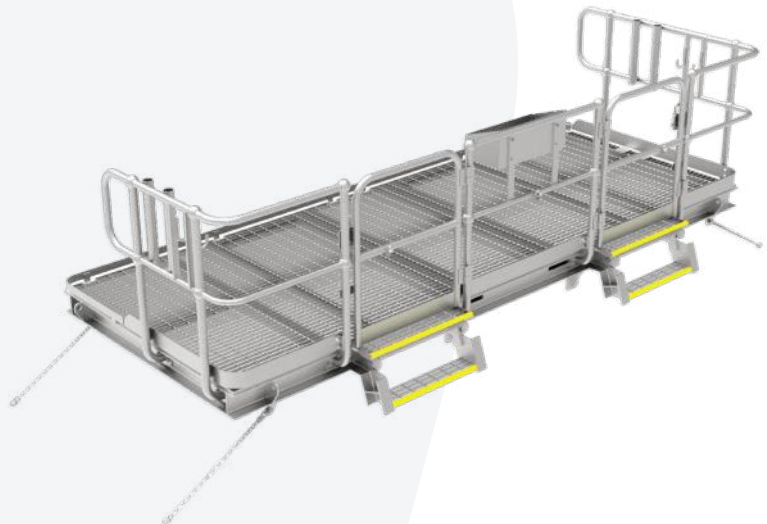

LIEBHERR 996 WHEEL LOADER

LIEBHERR 996 BUCKET ACCESS PLATFORM

Part No. 5501334

CONSTRUCTION

- Heavy-duty steel
- WLL: 250kg
- Fitted with self-closing gates
- Levelling jacks



LIEBHERR 996 BOOM ARCH HOSE ACCESS PLATFORM

Part No. 5501000

CONSTRUCTION

- Heavy-duty aluminium
- WLL: 150kg
- Fitted with lifting lugs
- Finished in Y-14 safety yellow
- Splits into two halves for ease of transport and fitment
- Certified and compliant with Australian Standards

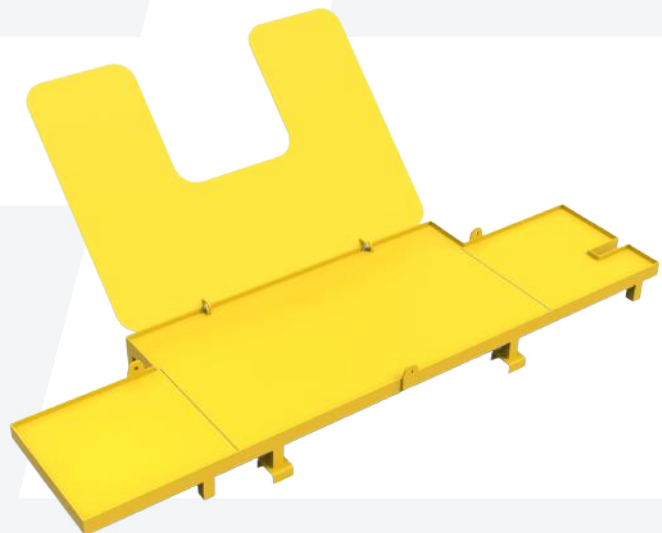

LIEBHERR 9400 EXCAVATOR

LIEBHERR 9250/9400 TRACK ACCESS PLATFORM

Part No. 5504920

CONSTRUCTION

- Heavy-duty steel
- WLL: 250kg
- Height: 2230mm
- Self closing gate
- Jack stands
- Fork pockets



LIEBHERR 9250/9400 TRACK WORK PLATFORM

Part No. 5504919

CONSTRUCTION

- Heavy-duty steel
- WLL: 500kg
- Length: 7000mm
- Drop in handrails
- Fitted with fork pockets
- Adjustable chain lock system

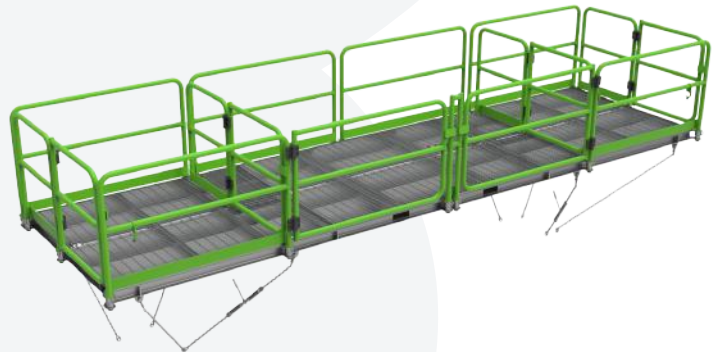

LIEBHERR 9400 SWING BOX ACCESS PLATFORM

Part No. 5505292

CONSTRUCTION

- Heavy-duty lightweight aluminium
- WLL: 150kg
- Jack stands
- Fitted with forklift slots
- German made castor wheels



VOLVO**L120F WHEEL LOADER**

A safe, certified and compliant access platform designed and engineered for the Volvo L120F Wheel Loader

CONSTRUCTION

- Heavy-duty aluminium
- Left and right-hand platforms for easy access on both sides of the loader
- Non-slip stairway and work area
- Safety handrails
- Overhangs for easy access
- Easy to move around the workshop while the loader is serviced
- Heavy duty caster wheels to detail

**VOLVO L120F
ACCESS PLATFORM****Part No. 5501968**

VOLVO **L120F WHEEL LOADER**

VOLVO L120F WINDSCREEN CHANGEOUT PLATFORM

Part No. 5504108

CONSTRUCTION

- Heavy-duty aluminium
- WLL: 150kg
- Non-slip nosings
- Self-closing gates
- High quality German made castor wheels
- Latch system included to attach two platforms to each other



VOLVO **A45G WHEEL LOADER**

VOLVO A45G ENGINE ACCESS PLATFORM

Part No. 5504579

CONSTRUCTION

- Heavy-duty aluminium
- WLL: 150kg
- Height: 1435mm
- Forklift slots
- Self-closing gate
- Safety handrails with kickplates
- Non-slip nosings on all stair treads
- Left hand and right hand are symmetrical



TAKE NOTE



B BIGGER THAN BUSINESS

TAKE NOTE



TAKE NOTE



EXPERIENCE OUR CONSULTING, DESIGN AND ENGINEERING SERVICE

Projects and the associated challenges often require custom solutions which our CDEC system facilitates. Consultation, Design, Engineering and Construction is our holistic approach to solution development, making maintenance on-site safe, efficient, and easy.



CONSULTATION

We come to you and visit your site to get a hands-on feel for your project. The aim of our consultation is to listen to and understand your requirements. If the project requires it, our 3D scanning capabilities will streamline measurement and data capture. This approach allows us to discuss your problem on-site, possible solutions, and the benefits we can offer.



DESIGN

After the consultation we go back to our design team to begin the development of your custom solution. Our team produce designs in CAD Design complete with all drafting documentation ensuring an advanced manufacturing process.



ENGINEERING

Once the design is approved, we begin the engineering process. This ensures that the right material grade is used for your project to guarantee structural and functional integrity. We provide full certification that includes WLL, load ratings, integrity reports as well as certification plates and identifications. We design and engineer all our solutions to ensure full compliance with Australian standards.

Our engineering department includes 9 draftsman and 14 engineers. We are experienced in the design and development of complex mechanical engineering analysis and solutions.



CONSTRUCTION AND FABRICATION

Our industry leading 10000 sq/m facility in Welshpool, Western Australia is armed with highly qualified consulting, drafting, engineering and fabrication personnel dedicated to manufacturing precision, engineered high performance industrial solutions.

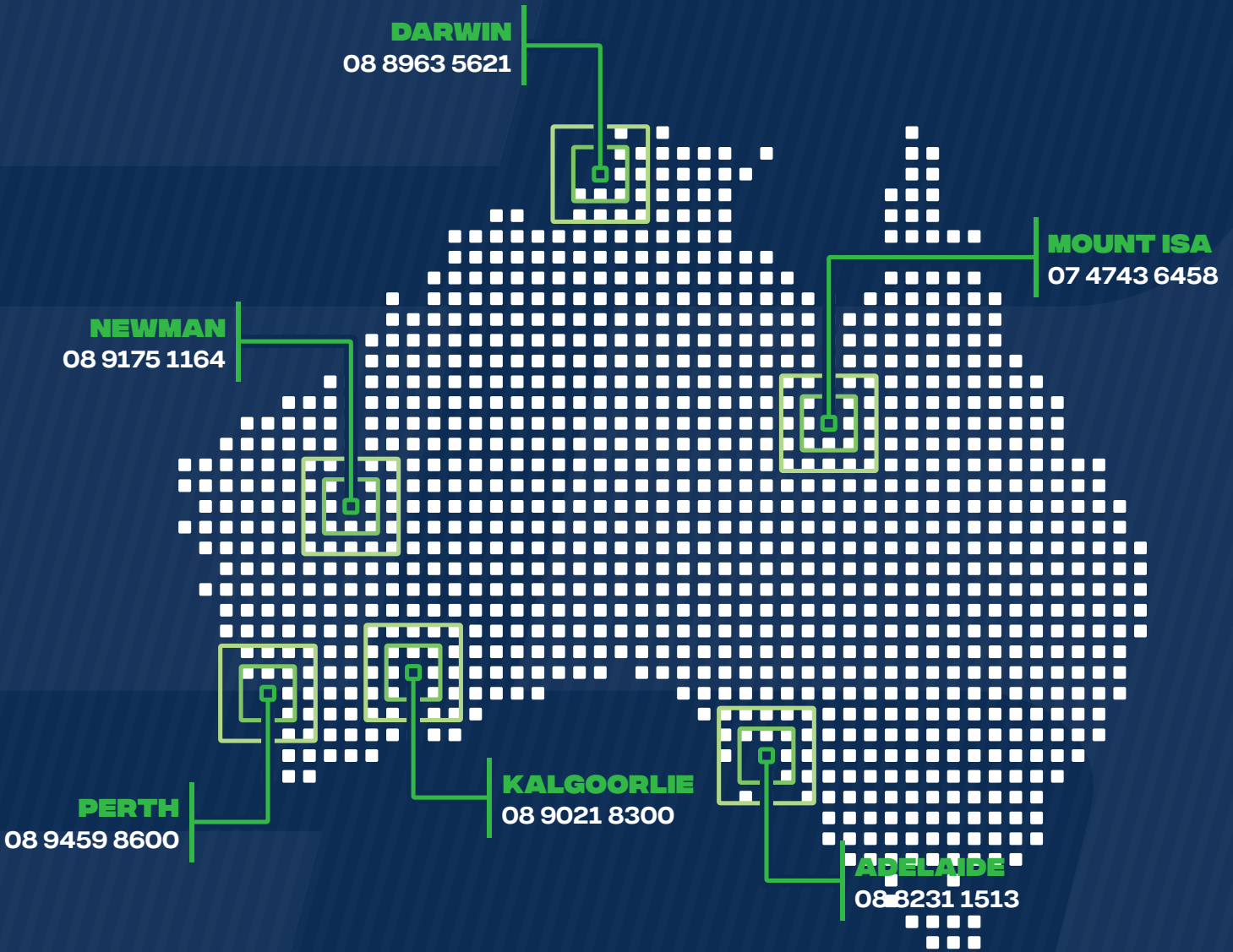

 sales@bendtechgroup.com.au

 www.bendtechgroup.com.au

