

5



Section 5

Modular Units & Custom Cabinetry

Contact us for a quote!

 sales@educatedfurniture.co.nz

 0508 645 397

 educatedfurniture.co.nz



The quality of products and the advice and guidance from the team at Educated Furniture, are unquestionably second to none.

I have moved around the country and have been the Principal in a variety of schools and I continue to purchase my school furniture from EF and have never been let down by quality or price.

My advice to any principal looking to purchase school furniture is to get a quote from Educated Furniture. You will save money and your children will benefit from excellent furniture.

Principal
Westbrook School | Rotorua

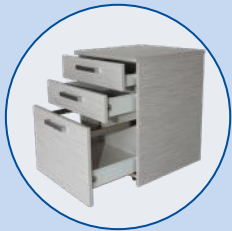

Section 5

Modular Units and Custom Cabinetry

iQuad Desk Units.....5-110

iQuad Mobile Units.....5-112

iQuad Credenza Units.....5-113

iQuad Storage Units.....5-114

Modular Units.....5-115

Custom Cabinetry.....5-118

iQuad Desk Units

Our iQuad Desk Units are a heavy duty, high quality storage solution with a range of options available. Made at standard desk height, they are designed to create an extension to your desk area or they can be banked together against a wall to create functional storage and an additional work surface. With solid matching backs, the units can also be used to create desk height 'partitions' in a large, open office space with the idea being that desk units can be mixed and matched to create a range of storage options.

808 iQuad Cupboard Desk Unit

- 800W x 600D x 725H
- 25mm carcass and shelves in your choice of colour/finish from our colour range below
- 18mm door fronts in your choice of colour/finish from our colour range below
- Option to have different colours/finishes on the carcass and cupboard doors
- Melteca matching back
- 50 x 50 x 80mm high steel square feet
- Cupboard doors have high quality, soft close Hettich hinges
- 1 adjustable shelf inside

Optional extras

- Add locks for added security

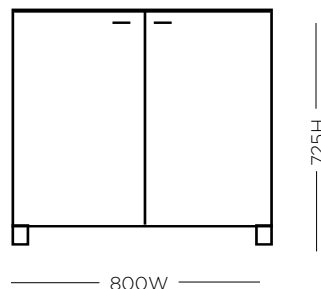

809 iQuad Shelving Desk Unit

- 800W x 600D x 725H
- 25mm carcass and shelves in your choice of colour/finish from our colour range below
- Option to have different colours/finishes on the carcass and shelves
- Melteca matching back
- 50 x 50 x 80mm high steel square feet

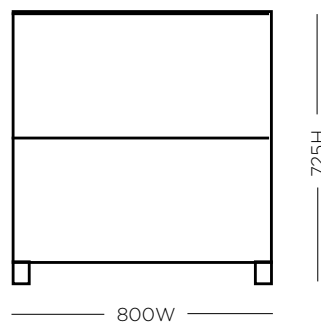

810 iQuad Drawer Desk Unit

- 800W x 600D x 725H
- 25mm carcass in your choice of colour/finish from our colour range below
- 18mm drawer fronts in your choice of colour/finish from our colour range below
- Option to have different colours/finishes on the carcass and drawer fronts
- Melteca matching back
- 50 x 50 x 80mm high steel square feet
- 4 drawers

Drawer hardware and specifications

- Hettich steel sided, MultiTech drawer system
- 12mm white MDF bases
- Capacity of up to 25kg per drawer
- Drawers can easily be removed when necessary

Optional extras

- Add locks to top drawer or
- Add gang lock to all drawers

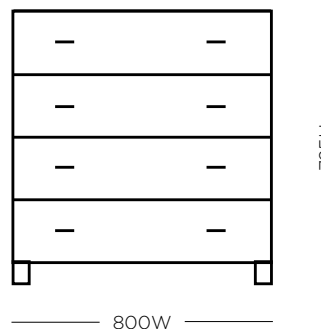

Standard drawers feature Hettich MultiTech drawer system - 25kg capacity



Colour range





iQuad Drawers and Hinges

Standard drawers feature Hettich MultiTech drawer system - 25kg capacity



All iQuad cupboards feature soft close Hettich Sensys hinges

Deep drawers feature Hettich InnoTech soft close drawer system - 30kg capacity



811 iQuad File Drawer Desk Unit

- 960W x 600D x 725H
- 25mm carcass in your choice of colour/finish from our colour range below
- 18mm drawer fronts in your choice of colour/finish from our colour range below
- Option to have different colours/finishes on the carcass and drawer fronts
- Melteca matching back
- 50 x 50 x 80mm high steel square feet
- 2 standard drawers and 1 deep file drawer

Drawer hardware and specifications

- Deep drawer: Hettich InnoTech soft close drawer system - 30kg capacity and 16mm white MDF bases
- Standard drawers: Hettich MultiTech drawer system with 25kg capacity and 12mm white MDF bases
- Drawers can easily be removed when necessary

Optional extras

- Add locks to top drawer or
- Add gang lock to all drawers

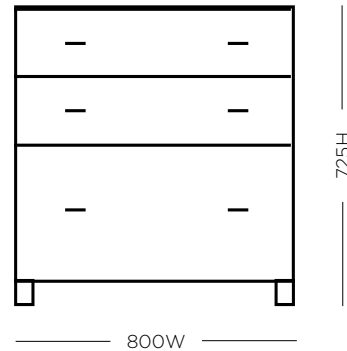

Colour range



iQuad Mobile Units

Our iQuad Mobile Drawer units are our highest quality mobile unit, made in heavy duty 18mm board and featuring our steel iQuad handles. Designed to fit tidily under your workstation or desk, our iQuad mobile units providing additional storage without taking up extra floor space. Both of our iQuad Mobile Units come with matching backs and can be ordered in two different colours. Our iQuad Mobile Units are designed so they can be paired with the rest of our iQuad range of desks, workstations and storage systems.

812 iQuad Mobile Four Drawer Unit

- 490W x 490D x 625H
- 18mm carcass in your choice of colour/finish from our colour range below
- 18mm drawer fronts in your choice of colour/finish from our colour range below
- Option to have different colours/finishes on the carcass and drawer fronts
- Melteca matching backs
- 4 drawers
- Come on twin wheel locking castors
- Heavy duty steel handles

Drawer hardware and specifications

- Hettich steel sided, MultiTech drawer system
- 12mm white MDF bases
- Capacity of up to 25kg per drawer
- Drawers can easily be removed when necessary

Optional extras

- Add locks to top drawer or
- Add gang lock to all drawers

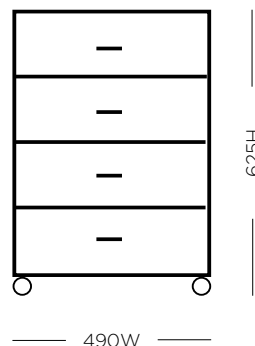

813 iQuad Mobile Three Drawer Unit

- 490W x 490D x 625H
- 18mm carcass in your choice of colour/finish from our colour range below
- 18mm drawer fronts in your choice of colour/finish from our colour range below
- Option to have different colours/finishes on the carcass and drawer fronts
- Melteca matching backs
- 2 drawers and 1 file drawer
- Come on twin wheel locking castors
- Heavy duty steel handles

Drawer hardware and specifications

- Hettich steel sided, MultiTech drawer system
- 12mm white Melteca bases
- Capacity of up to 25kg per drawer
- Drawers can easily be removed when necessary

Optional extras

- Add locks to top drawer or
- Add gang lock to all drawers

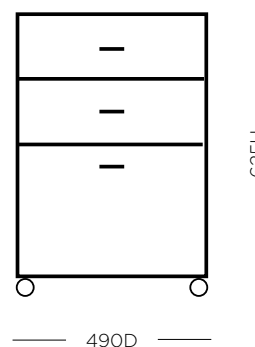

Colour range



iQuad Credenza Units

837 iQuad Credenza Units

Our iQuad Credenza Units come at desk height and are designed to create an extension to your desk area, or banked together to create functional storage in your office or administration area. Credenza Units come with solid matching backs so they can also be used as 'partitions' to break up a large office space into individual areas. They all come at the same height and depth so different Credenzas and Desk Units can be mixed and matched to create a range of storage options.

- Choose your width x 600D x 725H
- 25mm carcass in your choice of colour/finish from our colour range below
- 18mm door fronts in your choice of colour/finish from our colour range below
- Option to have different colours/finishes on the carcass and door fronts
- Melteca solid matching backs
- 6 size options to choose from
- 50 x 50 x 80mm high steel square feet
- Heavy duty steel handles
- Cupboard doors have high quality, soft close Hettich hinges
- 1 adjustable shelf inside

Optional extras

- Add locks to cupboards

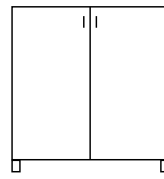

800W or 1000W

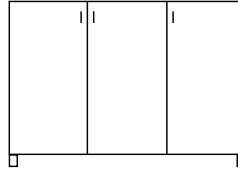

1200W or 1600W

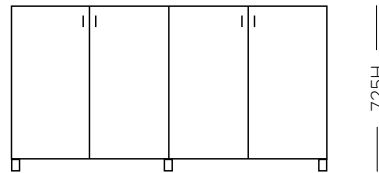

1800W or 2000W

725H

838 iQuad 'A' Units

Our high quality and heavy duty iQuad 'A' Units can be stand alone or banked together to create stylish and functional storage in your office or administration area. They come with solid matching backs so they can also be used as partitions to break up a large office space. All our iQuad A Units come at the same height and depth so they can be mixed and matched to create a range of storage options. They also pair nicely with the rest of our iQuad desks and storage range.

- Choose your width x 600D x 860H
- 25mm carcass in your choice of colour/finish from our colour range below
- 18mm drawer fronts in your choice of colour/finish from our colour range below
- Option to have different colours/finishes on the carcass and door fronts
- Melteca solid matching backs
- 8 size options to choose from
- 50 x 50 x 80mm high steel square feet
- Heavy duty steel handles

Drawer hardware and specifications

- File drawer: Hettich InnoTech soft close drawer system - 30kg capacity and 16mm white MDF bases
- Shallow drawers: Hettich MultiTech drawer system with 25kg capacity and 12mm white MDF bases
- Drawers can easily be removed when necessary

Optional extras

- Add locks to top drawer or
- Add gang lock to all drawers

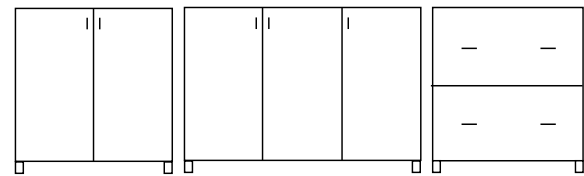

800W or 1000W

1200W or 1600W

960W
Double File
Drawers

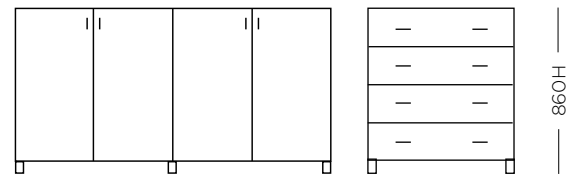

1800W or 2000W

800W
4 Drawer
Unit

860H



Colour range



iQuad Storage Units

These modular units can be mixed and matched to suit any office, staffroom, reception area, resource room or classroom - fitting together to create a tidy, practical and stylish solution to all your storage needs.

- All units 2000H x 400D or 600D
- 25mm carcass and shelves
- 18mm drawer fronts and doors
- 50 x 50 x 80mm high steel square feet
- Soft close doors
- High quality steel handles
- Melteca matching backs with the option to have different colours/finishes on the inside and outside of the unit



Optional extras

- Add locks to cupboards and or drawers

820-829 iQuad Storage Units 400D

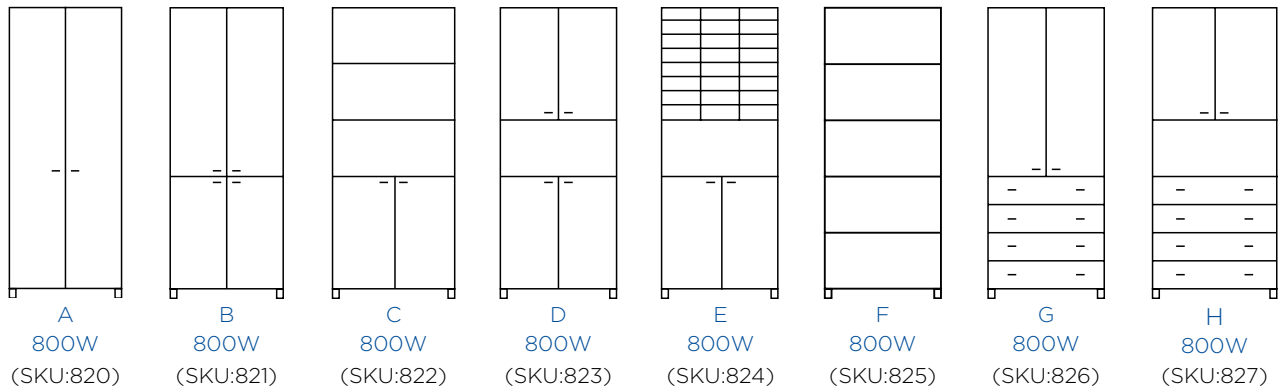

Hettich

iQuad Drawers and Hinges

We use high quality, soft close Hettich Sensys hinges on all our iQuad cupboard doors

Standard drawers feature the Hettich MultiTech drawer system - 25kg capacity

Deep drawers feature the Hettich InnoTech soft close drawer system - 30kg capacity

847-851 iQuad Storage Units 600D

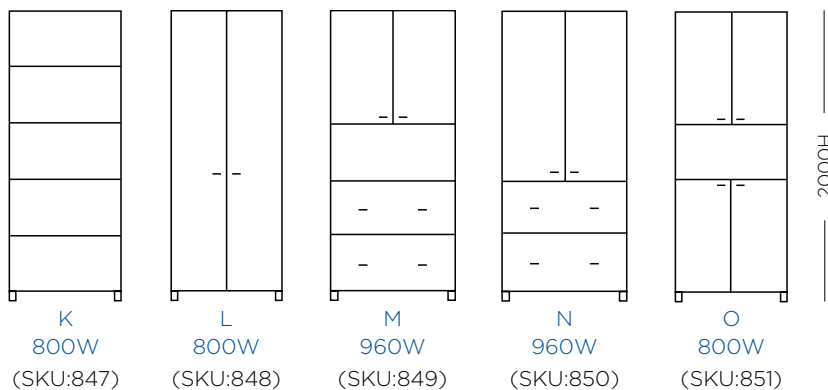

Colour range



Modular Units

Our modular units are a heavy duty and cost effective range of storage solutions that can be mixed and matched to suit any office, staffroom, reception area, lab room, STEM room, resource room or classroom - pairing together to create a tidy and practical solution to all your storage needs. All Modular Units feature high quality Hettich hinges and drawer systems and are available in our full range of colours/finishes to suit any environment.

550 Moby Unit

Our Moby Units are designed to fit tidily under your workstation or desk, providing additional storage without taking up extra floor space. Available in four different combinations and designed so they can be paired with the rest of our Modular Unit range.

- 490W x 490D x Height
- 18mm carcass and drawer fronts in your choice of colour/finish from our colour range below
- Come on twin wheel locking castors
- 4 drawer combinations to choose from
- Heavy duty steel bow handles

Drawer hardware and specifications

- Hettich steel sided, MultiTech drawer system
- Heavy duty drawers with 12mm white bases
- Drawers can easily be removed when necessary

Optional extras

- Add gang lock to all drawers

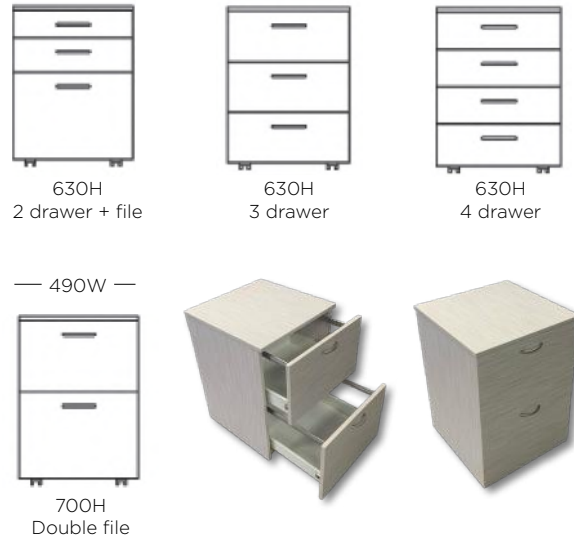

551 Bookcase Units

Our Bookcase Units work well in libraries, resource rooms, administration areas and classrooms. Available in eight different heights, our Bookcase Units are designed so they can be paired with the rest of our Modular Unit range as well as our workstations and desks.

- 800W x 300D x Choose your height
- 25mm carcass and shelves in your choice of colour/finish from our colour range below
- Come on plinth base
- Adjustable shelves with the option to order extra shelves if required
- 4mm white backs

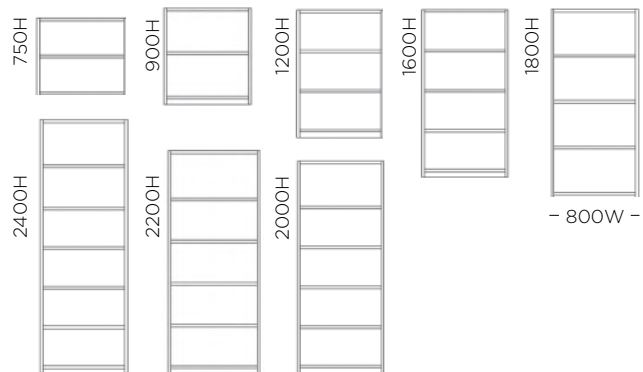

553 Cupboard Units

Our Cupboard Units work well in libraries, resource rooms, administration areas and classrooms. Available in five different heights, our Bookcase Units are designed so they can be paired with the rest of our Modular Unit range.

- 800W x 400D x Choose your height
- 25mm carcass and shelves in your choice of colour/finish from our colour range below
- 18mm doors in your choice of colour/finish from our colour range below
- Come on plinth base
- Adjustable shelves with the option to order extra shelves if required
- 4mm white backs
- Optional locks

Optional extras

- Add locks to cupboards

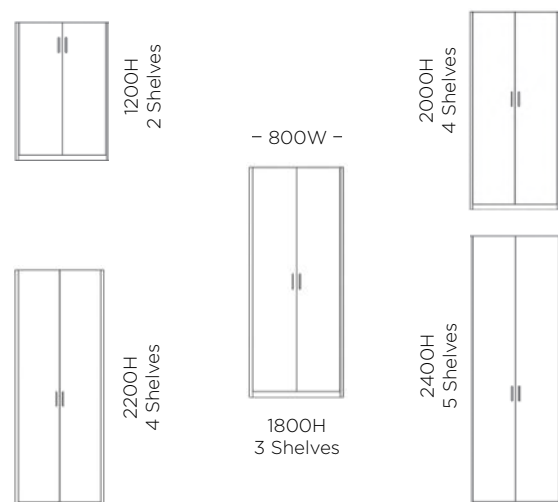

Colour range



554 Credenza Units

Our Credenza Units come at desk height and are designed to create an extension to your desk area, or can be banked together to create high quality, functional storage in your office or area. They all come at the same height and depth so different A units can be mixed and matched to create a range of storage options.

- Choose your width x 500D x 725H
- 25mm carcass in your choice of colour/finish from our colour range below
- 18mm door fronts in your choice of colour/finish from our colour range below
- Option to have different colours/finishes on the carcass and door fronts
- 4mm white backs
- 6 size options to choose from with plinth base
- Steel bow handles
- Cupboard doors have quality Hettich hinges
- 1 adjustable shelf inside

Optional extras

- Add locks to cupboards

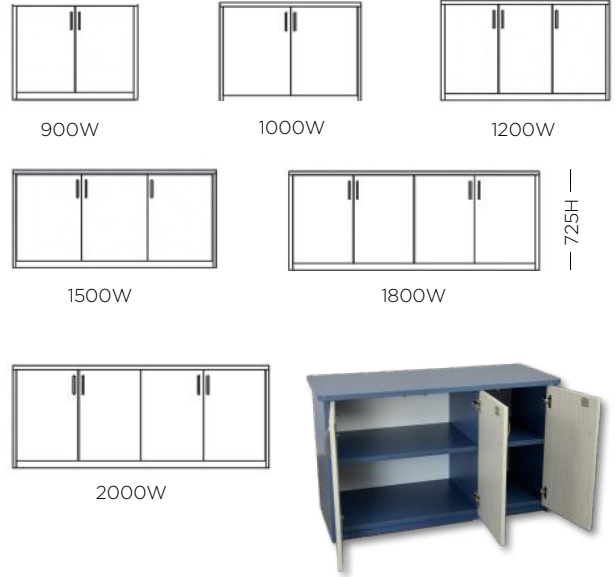

555 A Units

Our 'A' Units come at 900H and can be stand alone or banked together to create plenty of high quality, functional storage in your office or administration area. They all come at the same height and depth so different A units can be mixed and matched to create a range of storage options.

- Choose your width x 500D x 900H
- 25mm carcass in your choice of colour/finish from our colour range below
- 18mm door fronts in your choice of colour/finish from our colour range below
- Option to have different colours/finishes on the carcass and door fronts
- 4mm white backs
- 6 size options to choose from with plinth base
- Steel bow handles
- Cupboard doors have quality Hettich hinges
- 1 adjustable shelf inside

Optional extras

- Add locks to cupboards

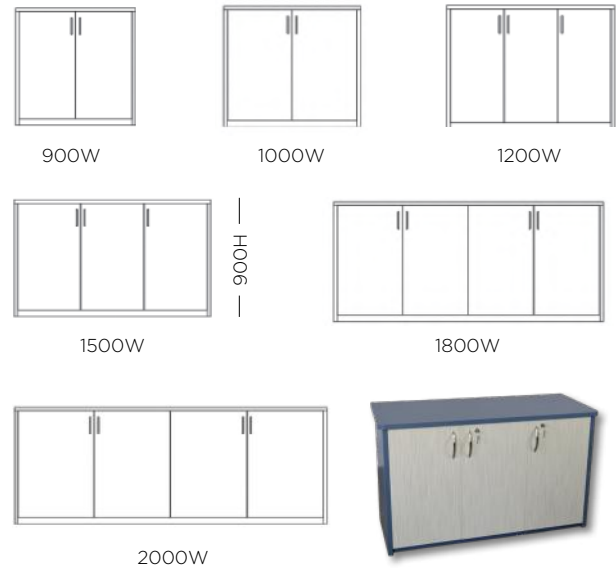

558 Wallmounted Bookcases

Our Wallmounted Bookcase Units come at 900H and can be installed as a stand alone piece or banked together to create large amounts of functional wall storage in an office, school lab, resource room, classroom or administration area.

- Choose your width x 300D x 900H
- 25mm carcass and shelves in your choice of colour/finish from our colour range below
- Option to have different colours/finishes on the carcass and door fronts
- Solid white 18mm white backs
- 4 size options to choose from with plinth base

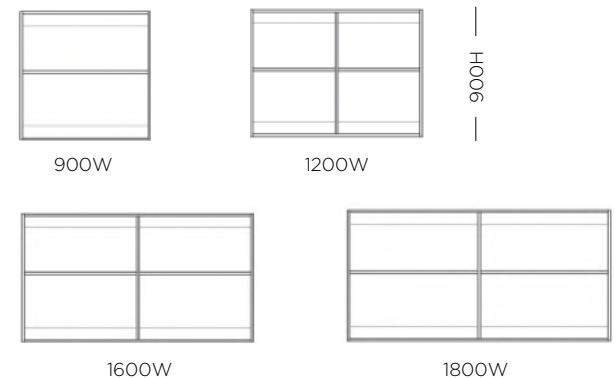

Colour range

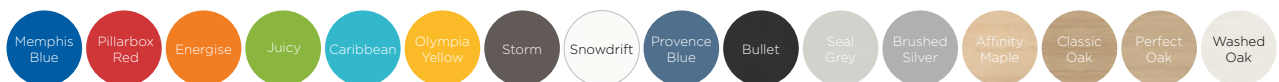

559 Wallmounted Cupboards

Our Wallmounted Bookcase Units come at 900H and can be installed as a stand alone piece or banked together to create large amounts of functional wall storage in an office, school lab, resource room, classroom or administration area.

- Choose your width x 320D x 900H
- 25mm carcass and shelves in your choice of colour/finish from our colour range below
- Option to have different colours/finishes on the carcass and door fronts
- Solid white 18mm white backs
- Steel bow handles
- Cupboard doors have quality Hettich hinges
- 4 size options to choose from with plinth base

Optional extras

- Add locks to cupboards

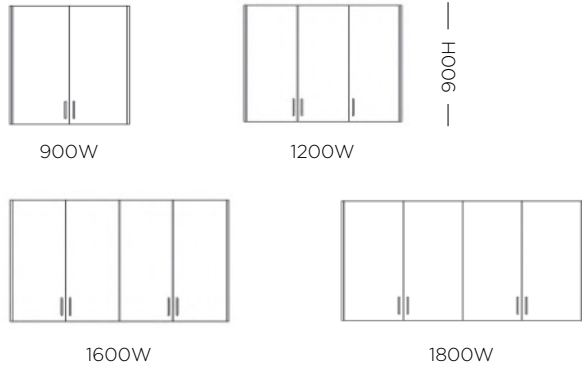

560 Wall Units

Our Wall Units combine our credenza units with hutch shelving above and come in four size options. They can be installed as a stand alone piece or banked together to create large amounts of shelving and cupboard storage in an office, staffroom, resource room, classroom or administration area.

- 2000H x 300D hutch x 500D credenza
- Choose your width
- 25mm carcass and shelves in your choice of colour/finish from our colour range below
- Option to have different colours/finishes on the carcass and shelves/door fronts
- Solid white 18mm white backs
- Steel bow handles
- Cupboard doors have quality Hettich hinges
- 4 size options to choose from with plinth base

Optional extras

- Add locks to cupboards

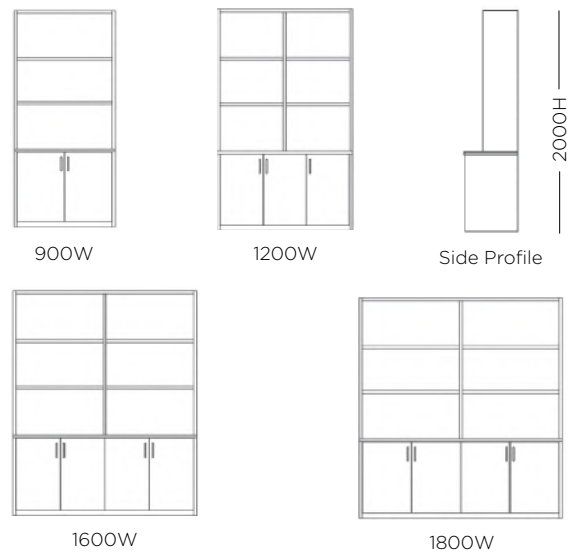

Colour range



Custom Cabinetry

In addition to our extensive range of furniture, we also manufacture and install custom cabinetry. Our factory has the capability to produce built-in cabinetry to any specification and for any environment, including kitchens, bathrooms, wet areas, changing rooms, storage spaces, staffrooms and resource rooms.

All our cabinetry comes with quality soft close Hettich drawer and hinge systems and can be made in any colour/finish required.

Our Account Managers can help you every step of the way, from assisting with the design and layout, to overseeing installation.

Contact us today to turn your vision into a reality.



Case Study

Kotata Early Childhood Centre

In early 2023 EF completed a large scale custom cabinetry fit out at a brand new ECE in central Whangarei. We liaised closely with both the architect, (who had designed the centre) and the head contractor to ensure the best solution was provided to the client. Ultimately the fit-out included the manufacture, supply and installation of the following units:

- Custom made reception desk with integrated drawers and hutch. This was made to measure, built around walls and pillars and included cable ducting for data and power to be fitted tidily within the desk.
- Staffroom lockers - all doors individually locked and numbered.
- Staffroom kitchen - made to customer specifications with fridge surround and Formica benchtops with coved upstands.
- Main kitchen - commercial grade kitchen units to suit commercial appliances, complete with full custom stainless steel bench tops
- Multiple changing rooms - these included change table bench units with Formica tops and integrated pull out steps, with cupboards and overhead storage for nappies and changing aides.
- Art bench units with overhead storage - split level for adult / toddler use with Formica bench tops and coved upstands.
- Multiple kitchenettes made to customer specifications with fridge surround and Formica benchtops with coved upstands
- Laundry - full built in laundry cabinets with wrap around overhead storage
- Built-in wave shaped shelving units for a large resource room/storage area



Colour range

