

FOSHAN
SINOLE
MEDICAL DEVICES CO.,LTD



佛山市鑫诺尔医疗器械有限公司
FOSHAN SINOLE MEDICAL DEVICES CO.,LTD.

地址：佛山市南海区狮山镇罗村联和工业区联和大道5号
电话：0757-81763102
手机：+86-18823104075 +86-13620818037
邮箱：fsxneyl@126.com
网址：www.sinole.com
Add: No.5 Lianhe Road,Lianhe avenue,Luocun,Nanhai,Foshan,China
Tel: +86-757-81763102
Mobile: +86-18823104075 +86-13620818037
E-mail: info@sinole.com sales1@sinole.com
Website: www.sinole.com



微信公众号



手机画册

2020 产品手册
PRODUCT MANUAL
YEARS
佛山市鑫诺尔医疗器械有限公司

COMPANY HONOR

公司荣誉



ABOUT US

关于我们

佛山市鑫诺尔医疗器械有限公司是一家集研发、制造、销售、工贸为一体的综合性公司，拥有18年口腔器械专业制造经验，自主研发产品及配套加工。主要产品有：注油机、封口机、紫外线储存柜、移动小推车、移动边柜、枕头架、强弱吸、三用枪、阀体、牙椅配件及相关配套产品。本公司特点：产品多元化、专业专注、勇于创新、质优物美、受到国内外业内同仁的一致认可。

“众诚厚德，业精致远”是我们鑫诺尔人恪守的经营理念。团结、和谐、友爱是我们处事的原则。务实、创新、精益求精、科学发展是我们的宗旨，我们将会尽全力以提供更优质的产品、更贴心的服务、与广大业内同仁携手创造口腔器械更好的明天！

Foshan Sinole Medical Devices Co., Ltd. is a comprehensive company integrating R&D, manufacturing, sales, industry and trade. It has 18 years of professional dental device manufacturing experience and independently develops products and complete sets of accessories. The main products are: oil injection machine, sealing machine, ultraviolet storage cabinet, mobile trolley, mobile side cabinet, pillow frame, strong and weak suction, three-purpose gun, valve body, dental chair accessories and related supporting products. The company's characteristics: product diversification, professional focus, innovation, high quality and good quality, unanimously recognized by colleagues in the industry at home and abroad.

"All honesty and honesty, exquisiteness and far-reaching industry" is our Sinole business philosophy. Unity, harmony, and fraternity are our principles. Pragmatism, innovation, excellence, and scientific development are our tenet. We will do our best to provide better products, more considerate services, and work with colleagues in the industry to create a better tomorrow for dental instruments!

CONTENTS

目录

01-03	三用枪系列 3 Way Syringe Series	04	喷杆系列 Syringe Tips Series
05-06	枕头架系列 Pillow Rack Series	07-08	注油机系列 Handpiece Lubricator Series
09-10	封口机系列 Sealing Machine Series	11-12	消毒系列 / 紫外线储存柜系列 Disinfection Series / UV Sterilizer Series
13-14	加热器系列 / 维修工具系列 Composite Heater series / Maintenance Tool Series	15-16	移动收纳柜 / 移动推车系列 Mobile Storage Cabinet / Trolley Series
17-18	空压机 / 折叠椅 / 雕刻机系列 Air Compressor / Portable Chair / Turbine Machine Series	19-20	器械架 / 打磨机 / 光固化 / 洁牙机系列 Instrument Rack / Micromotor / Curing Light / Scaler Series
21-22	头灯放大镜系列 / 无影灯系列 Dental Loupes Series / Shadowless Lamp Series	23-24	口腔灯系列 / 平衡臂系列 Dental Lamp Series / Balance Arm Series
25-26	椅子系列 / 布套系列 Doctor Chair Series / Dental Chair Cloth Cover Series	27-28	附加台系列 3 in 1 Tissue Box Series
29-30	强弱吸系列 Strong And Weak Suction Series	31-32	脚踏系列 / 牙椅配件工具盘 Foot Control series / Dental Chair Accessories Tool Tray
33-36	牙椅配件系列 Dental Chair Accessories Series	37-38	根管治疗系列 / 高速手机系列 Root Canal Treatment Series / High- Speed Handpiece Series
39-40	低速手机系列 / 公司历程 Low-Speed Handpiece Series / Company History		



STRAIGHT SYRINGE
三用枪套装



01-01



产品规格 SPECIFICATION

三用枪套装产品配置	3 way syringe configuration
喷杆10支	10 tips
枪头销钉1根	Removable pin 1pcs
按键弹簧4个	Button spring 4pcs
按键整套2套	2 sets of buttons
3.2接嘴2个	3.2 connector 2pcs
2.7接嘴2个	2.7 connector 2pcs
6*1密封圈2个	6*1 sealing rings 2pcs
5*1密封圈8个	5*1 sealing rings 8pcs
4*12密封圈4个	4*12 sealing ring 4pcs
6.1*1.8密封圈4个	6.1*1.8 sealing ring 4pcs
4.65*15密封圈2个	4.65*15 sealing rings 2pcs
六角扳手1个	Hexagon wrench 1pcs
三用枪（不锈钢手柄）1支	stainless steel handle 1pcs



01-02



型号Model: XNR-SQ2

产品规格 SPECIFICATION

品名：三用枪
型号：XNR-SQ2
规格：2.7/3.0/3.2可选

Product name: Bend Syringe
Model: XNR-SQ2
Specifications: 2.7/3.0/3.2optional
(connector size)

STRAIGHT SYRINGE
三用枪



02-01

型号Model: XNR-SQ1



产品规格 SPECIFICATION

品名：三用枪
型号：XNR-SQ1
规格：2.7/3.0/3.2可选

Product name: Straight Syringe
Model: XNR-SQ1
Specifications: 2.7/3.0/3.2optional
(connector size)



型号Model: XNR-SQ1

绿色
Green
02-02



型号Model: XNR-SQ1

浅蓝色
Light Blue
02-03



型号Model: XNR-SQ1

深蓝色
Dark Blue
02-04



02-05

型号Model: XNR-SQ3



产品规格 SPECIFICATION

品名：三用枪
型号：XNR-SQ3
规格：2.7/3.0/3.2可选

Product name: Straight Syringe
Model: XNR-SQ3
Specifications: 2.7/3.0/3.2optional
(connector size)





EUROPEAN AND AMERICAN MODELS

欧式三用枪



03-01

型号Model: XNR-SQ(EU4)

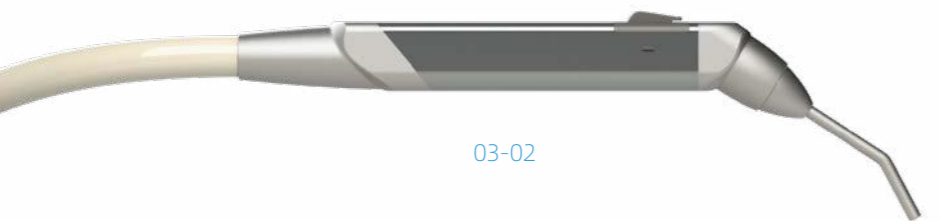

03-02

QUICK CONNECT 3 WAY SYRINGE

快接三用枪



03-03

型号Model: XNR-SQ(Q3)



03-04



04-01

三用枪喷杆
Syringe Tips



04-02

三用枪喷杆消毒盒
Syringe Tips Disinfection Box



04-03

冲洗喷杆
Syringe Nozzle



04-04

一次性喷杆
Disposable Syringe Tips





PILLOW RACK
枕头架



05-01
(H2型)



产品特点 FEATURES

采用插销式齿轮传动技术，全金属机构，内置工程塑料固定板，外壳无可视螺丝孔位。
It adopts bolt-type gear transmission technology, all-metal mechanism and built-in engineering plastic fixing plate.

PILLOW RACK
枕头架



06-01
(H1型)



产品特点 FEATURES

按压式枕头架，单手按压式操作，345°角可任意调节，采用最新齿轮传动技术，全金属构造。
Press-type pillow rack, one-handed operation, 345° angle can be adjusted. using the latest ratchet drive technology, all metal construction.

PILLOW RACK
枕头架



06-02
(H3型)



产品特点 FEATURES

旋压式枕头架，单手旋压操作，头枕调节角度为345°任意角调节。手感舒适轻松。
采用最新滚花式齿合抱紧技术，松紧方便快捷。
金属与工程塑料完美结合，使用寿命长。

Spin-on pillow rack, one-handed spinning operation, the headrest adjustment angle is 345° arbitrary angle adjustment. hand Feel comfortable and relaxed.
With the latest knurled tooth-clamping technology, the tightening is quick and easy.
Metal and engineering plastics combine perfectly for long life.





HANDPIECE LUBRICATOR

手机清洗注油机



07-01



型号Model: HP600

产品规格 SPECIFICATION

额定电压Operating voltage	AC 220V 50Hz/AC 110V 60Hz (可选) (Optional)
额定功率Rated power	40W
空气源压力Import pressure scope	4kg/cm ² -8kg/cm ²
工作压力Working pressure	2.2kg/cm ² -8kg/cm ²
油罐容量Volume of groove cavity	220ml×2
工作环境温度Operating temperature	5°C-40°C
含包装重量Weight with package	14kg单台/58kg四台
外包装尺寸Packing size	41×39×45cm单台/83×81×48cm四台

HANDPIECE LUBRICATOR

手机注油机



08-01
型号Model: HP300 II



产品规格 SPECIFICATION

额定电压Operating voltage	AC 220V 50Hz/AC 110V 60Hz (可选) (Optional)
额定功率Rated power	40W
空气源压力Air source power	4kg/cm ² -8kg/cm ²
工作压力Working pressure	2.2kg/cm ² -8kg/cm ²
油罐容量Volume of groove cavity	300ml
工作环境温度Operating temperature	5°C-40°C
含包装重量Weight with package	7kg(单台)/30kg (四台)
外包装尺寸Packing size	32×26.5×38.5cm(单台)/65×56×41cm (四台)



型号Model: HP-300I
08-02



注油机润滑油
Lubricator Oil
08-03



A B
300ml 550ml
清洗剂
Handpiece Spary
08-04

产品规格 SPECIFICATION

额定电压Operating voltage	AC 220V 50Hz/AC 110V 60Hz (可选) (Optional)
额定功率Rated power	40W
空气源压力Air source power	4kg/cm ² -8kg/cm ²
工作压力Working pressure	2.2kg/cm ² -8kg/cm ²
油罐容量Volume of groove cavity	300ml
工作环境温度Operating temperature	5°C-40°C
含包装重量Weight with package	7kg(单台)/30kg (四台)
外包装尺寸Packing size	32×26.5×38.5cm(单台)/65×56×41cm (四台)





SEALING MACHINE WITH PRINTING

带打印封口机



09-01



型号Model: AS-1

工作条件 WORKING CONDITIONS

环境温度Ambient Temperature	0°C~40°C
相对湿度Relative Humidity	≤80%
大气压力Atmospheric Pressure	80kPa~106kPa
电源Power Supply	A.C.220V±22V 50Hz±1Hz
输入功率Input Power	500W
存储环境、温度Storage Environment and Temperature	-40°C~55°C
湿度Humidity	≤90% (R.H)

性能指标 WORKING CONDITIONS

传送纸张的速度为：7.5m/min;
 打印项目依次为：灭菌日期，失效日期，批号，操作人员姓名，锅号，锅次，物品名称，科室；
 打印全部选项所需袋宽：101mm（窄体）136mm（正常）175mm（宽体）
 工作温度：60~210°C可调 控温精度≤1%
 封口留边：0~35mm
 封合线宽度：12mm
 打印方式：针式打印

The speed of conveying paper : 7.5m/min;
 The print items are: sterilization date, expiration date, batch number, operator name, pot times, pot number, item name, department;
 Bag width required for printing all options: 101mm (narrow body) 136mm (normal) 175mm (wide body)
 Working temperature: 60~210°C adjustable, temperature control accuracy ≤1%
 Sealing and leaving side: 0~35mm
 Sealing line width: 12mm
 Printing method: stylus printing

INTELLIGENT SEALING MACHINE

智能封口机

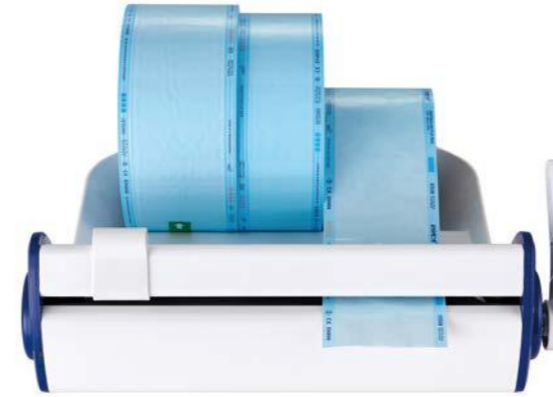
型号Model: S-3
10-01

产品规格 SPECIFICATION

额定电压Operating voltage	220V 50Hz
额定功率Rated power	300W
封口宽度Width of sealing	0-300mm (最大)
压痕宽度Width of indentation	12mm

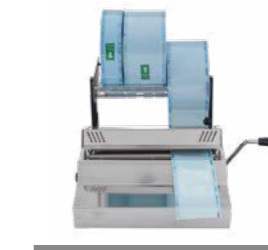
型号Model: S-1
10-02

产品规格 SPECIFICATION

品名Product name	立式封口机Sealing Machine
电压Voltage	AC220V 50Hz-60Hz
功率Power	500W
封口机宽度Sealing width	0-250mm
压痕宽度Width of indentation	10mm





11-01

产品规格 SPECIFICATION

品名Product name	超声波清洗机Ultrasonic Cleaner
额定电压Operating voltage	220V 50Hz
超声波功率Operating voltage	120W
超声波频率Ultrasonic power	40KHz
加热功率 Ultrasound frequency	90W
时间范围Heating power	1-99min
加热范围Time limit	0-80°
内槽尺寸Inner groove size	240×140×150mm
容量Capacity	5L
含包装重量 Weight with package	4.5kg
包装尺寸Packing size	36×25×32cm



单开门定时款
Single-Door Definite Time Model
12-01
型号Model: SS-1601D



单开门常规款
Single-Door Regular Model
12-02
型号Model: SS-1601

产品规格 SPECIFICATION

品名Product name	紫外线储存柜 (单门) Ultraviolet Sterilization Cabinet
规格Specifications	带定时/不带定时, 带臭氧/不带臭氧, 金属盘/塑料盘 (可选) With timing/without timing, with ozone / ozone-free, metal plate / plastic plate(optional)
额定电压 Operating voltage	220V 50Hz
额定功率 Rated power	15W
容量Capacity	27L
消毒时间 Disinfection time	15min
含包装尺寸 Packing size	36×28×59cm (单台) 59×38×62cm (两台)
含包装重量 Weight with package	9.6~11kg (单台) 19.5~21kg (两台)



11-02

产品规格 SPECIFICATION

品名Product name	蒸馏水机Water Distiller
额定电压Operating voltage	220V 50Hz
额定功率Power	750W
容量Capacity	4L
蒸馏量Distillation volume	1L/H
超温保险器 Over-temperature protection	切断温度160°C Cutting temperature 160°C
含包装重量 Weight with package	4.7kg (单台)
包装尺寸Packing size	47×26.5×34cm (单台)

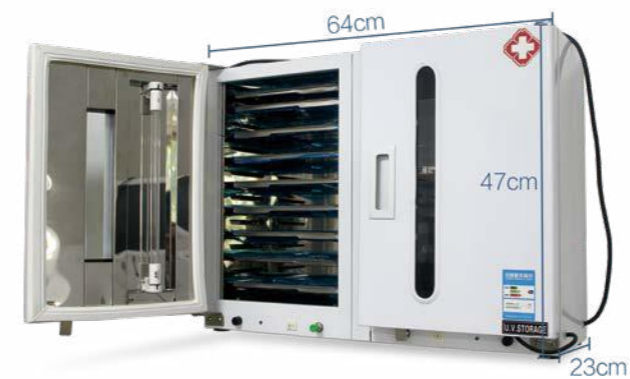

12-03
型号Model: SS-1602

产品规格 SPECIFICATION

品名Product name	紫外线储存柜 (双门) Ultraviolet Sterilization Cabinet
规格Specifications	带定时/不带定时, 带臭氧/不带臭氧, 金属盘/塑料盘 (可选) With timing / without timing, with ozone / ozone-free, metal plate / plastic plate(optional)
额定电压 Operating voltage	220V 50Hz
额定功率 Rated power	30W
容量Capacity	54L
消毒时间 Disinfection time	15min
含包装尺寸 Packing size	69×28×58cm
含包装重量 Weight with package	17.5~19.5kg



11-03

产品规格 SPECIFICATION

品名Product name	灭菌袋Sterilization Pouch
规格 Specification	5.5cm×200m 7.5cm×200m 10cm×200m 15cm×200m 20cm×200m 25cm×200m 30cm×200m 35cm×200m 40cm×200m



12-04
型号Model: DU-1

产品规格 SPECIFICATION

品名Product name	紫外线灯Ultraviolet Lamp
额定电压 Operating voltage	220V 50Hz
额定功率 Rated power	36W
容量Capacity	60L
消毒时间 Disinfection time	15min
含包装尺寸 Packing size	20×18×38cm
遥控开关 Remote control	30分/60分两档可选30min/60min for optiona
自动升降 Automatic lifting	外置指示灯External indicator





COMPOSITE HEATER

树脂加热器



13-01

型号Model: SH-100

产品规格 SPECIFICATION

品名Product Name	树脂加热器Composite Heater
供电电源Power supply	100-240V,50-60Hz
输入总功率Inpower power	11W
运行储存环境Operating storage environment	温度Temperature-10°C~60°C 湿度 Humidity<90%
加热温度范围HotHeating temperature range	30°C~70°C
环境污染Environmental pollution	符合环保标准Compliance with Environmental Standards
净重Net weight	1.15kg
供电线缆长度Supply cable length	2m

产品规格 SPECIFICATION

品名Product Name	多功能加热器 Composite Heater	遮光范围 Shading range	< 500NM
输入Enter	220V 50Hz~60Hz	使用环境温度 Use environment temperature	5°C~35°C
输出Output	24VDC2A	温度范围 Temperature range	RT+5°C~100°C
主机功率Monitor rate	26W	温度控制范围 Temperature control range	≤±0.3°C
温度模 (P) Temperature mode	36°C 45°C 70°C 100°C	主体外形尺寸 Main body size(L×W×H)	75mm×75mm×60mm
温度模式加热时间 Heating time intemperature mode	20" 50" , 2分钟, 3分50" 20" 50" , 2mins, 3mins50"	净重Net weight	1.17kg



型号Model: MH-1

13-02

产品规格 SPECIFICATION

品名Product Name	恒温孵化器Incubator
输入Input Power	220V 50Hz~60Hz
输出Output Power	24VDC2A
主机功率Host Power	26W
温度模式 (P) Temperature Mode	36°C 45°C 70°C 100°C
温度模式加热时间Heating Time in Temperature Mode	20" 50" 2分钟 3分50"
遮光范围Shading Range	<500nm
使用环境温度Ambient Temperature	5°C~35°C
温度范围Temperature Range	RT+5°C~100°C
温度控制范围Temperature Control Range	≤±0.3°C
加热主体外形尺寸(L×W×H)Heating Body Dimensions	75mm×75mm×60mm
孵化器主体尺寸(L×W×H) Incubator Body Dimensions	76mm×76mm×47mm
净重Net Weight	0.8KG



13-03

型号Model: CT-01

HANDPIECE MAINTENANCE TOOLS

手机维修工具



14-01

型号Model: HMT-1



产品特点 FEATURES

适用范围:

本产品适用于牙科医疗上的绝大部分高速手机维修。

Scope of application:

This product is suitable for most high-speed handpiece repair in dental.



低速维修工具
Low Handpiece Maintenance Tools
型号Model: HMT-2

14-02



机芯维修工具
Cartridge Maintenance Tools
型号Model: HMT-3

14-03



低速维修扳手
Low Speed Handpiece Maintenance Wrench
型号Model: HMT-4

14-04



手机手柄机头维修工具
Handpiece Body Maintenance Tools
型号Model: HMT-5

14-05





型号Model: M-511



15-01



15-02



15-03



15-04

产品特点 FEATURES

优质不锈钢柜身非常坚韧，防指纹，防腐蚀，永不生锈，经久耐用。底部优质软橡胶万向轮，可移动方便医务人员操作，可刹车锁定轮子。
High quality stainless steel cabinet, very tough, anti fingerprint, corrosion protection, never rust, durable. The bottom of high-quality soft rubber universal wheel, can be easily moved, followed by medical personnel to operate, can brake and lock the wheel.

产品规格 SPECIFICATION

型号Model	XY-002
柜体规格Cabinet size	840×500×500mm
重量Weight	35kg
可选颜色Optional Color	蓝色、绿色、白色 Blue、Green、White



型号Model: M-533
15-05



型号Model: M-W413
15-06



型号Model: M-311
15-07



16-01
型号Model: T1

产品规格 SPECIFICATION

型号Model	T1	
总高度Total height	711mm	
各层尺寸 Size of each layer	上层Top layer	380mm×374mm
	中层Middle layer	321mm×203mm
	下层Under layer	400×360mm
净重Net weight	17.5kg	
毛重Gross weight	19kg	
包装尺寸Packing size	630×390×130mm	



16-02
型号Model: T3

产品规格 SPECIFICATION

型号Model	T3	
总高度Total height	760mm	
各层尺寸 Size of each layer	上层Top layer	385×365mm
	中层Middle layer	310×220mm
	下层Under layer	395×400mm
净重Net weight	20kg	
毛重Gross weight	21.5kg	
包装尺寸Packing size	740×450×230mm	



16-03
型号Model: T5

产品规格 SPECIFICATION

型号Model	T5	
总高度Total height	785mm	
各层尺寸 Size of each layer	上层Top layer	400×430mm
	中层Middle layer	350×330mm
	下层Under layer	520×450mm
净重Net weight	16.5kg	
毛重Gross weight	19kg	
包装尺寸Packing size	760×450×170mm	





17-01

产品规格 SPECIFICATION

品名Product name	空压机 Air Compressor
电源Voltage	220VAC 50Hz
电流Electric current	2.4A
功率Power	545W
频率Frequency	70L/min
启动压力Starting pressure	0.5Mpa
工作压力Capacity pressure	0.8Mpa
气罐容积Air tank volume	32L
噪音Noise	55-62dB
毛重G.W	27kg
包装尺寸Packing size	43x43x70cm



全折叠椅 (基本款)
18-01



全折叠椅 (中配款)
18-02



全折叠椅 (高配款)
18-03

产品规格 SPECIFICATION

Product name	Portable Chair
品名	豪华型-全折叠椅
产品名称	全折叠椅 (基本款)
配置	折叠椅1套/金属托盘 充电式LED灯1套
包装尺寸	97x64.5x32.5cm
重量	31kg

产品规格 SPECIFICATION

Product name	Portable Chair
产品名称	全折叠椅 (中配款)
配置	全折叠椅1套/塑料痰盂1套/ 充电式LED灯1套/冲供水系统 1套/小涡轮机1台/①弱吸1 套/金属托盘
包装尺寸	97x64.5x32.5cm
重量	32kg

产品规格 SPECIFICATION

Product name	Portable Chair
产品名称	全折叠椅 (高配款)
配置	折叠椅1套/塑料痰盂1套/充 电式LED灯1套/冲供水系统 1套/小涡轮机1台/①弱吸1 套/②三用枪1套/③高速手机 管接口1套/④低速手机管接 口1套/金属托盘
包装尺寸	97x64.5x32.5cm
重量	36kg



17-02

产品规格 SPECIFICATION

品名 Product name	污水处理器 Sewage Disposal Unit
电源Voltage	220VAC 50Hz
功率Ultrasonic power	60W
频率Frequency	300L/H
宽度Width	3m
高度Height	20m
处理室密度 Dosing room density	30cm



18-04
便携式雕刻机
Turbine Machine



18-05
便携式雕刻机
Turbine Machine



17-03

产品规格 SPECIFICATION

品名 Product name	移动抽吸机 Mobile Suction Unit
电源Voltage	220/110V 50/60Hz
电流Current	2.0A
功率Power	0.20kW
最高真空 The max vacuum	-11Kpa
噪音Noise	<50dB
重量Weight	24.5kg
包装尺 Packing size	48x44x89cm



18-06
三联壁挂小雕刻机
Turbine Machine



18-07
金属小雕刻机
Metal Turbine Machine



18-08
塑料小雕刻机
Plastic Turbine Machine



INSTRUMENT RACK

正畸钳架

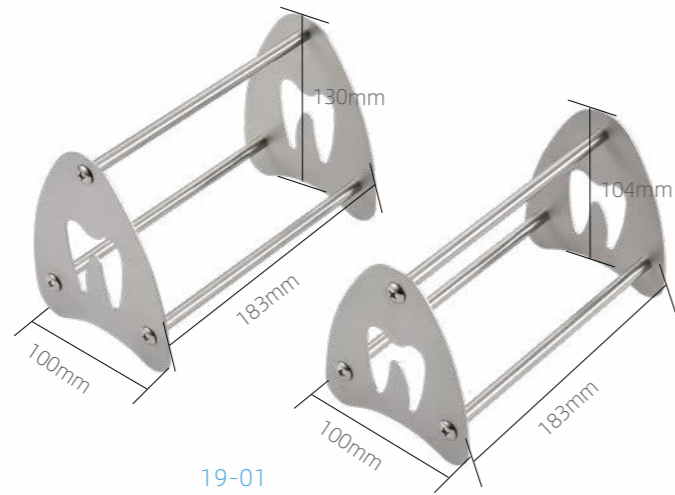

19-01

TECHNICIAN SERIES

技工系列



19-02

无碳刷打磨机
Brushless Micro Motor



19-03

204打磨机
204 Micro Motor



19-04

90打磨机
90 Micro Motor



19-05

真空压膜机
Vacuum Forming Machine



19-06

石膏震荡机
Plaster Rocker



19-07

压膜片
Membrane



三秒固化
3 Seconds Solidify
20-01

产品规格 SPECIFICATION

工作功率 Working power	DC3.7V, Class: II Ip40
输入电源 Input voltage	AC100-240V 50-60Hz
电池Battery	Lithium Bettary 2200Mah
光强度 Light intensity	1000~1600mW/cm ²



光固化II
Curing Light II
20-03

产品规格 SPECIFICATION

充电电池 Rechargeable battery	7V-4.2V
充电器工作电压 Charger working voltage	AC110-220V 50-60Hz
波长Wave length	420-480mm
光强度Light intensity	1200mw/cm ² 1500mw/cm ²



光固化I
Curing Light I
20-02

产品特点 FEATURES

三种模式：全功率模式，渐强模式，闪亮模式
3Modes: Full power mode, Crescendo mode, Flash mode

产品规格 SPECIFICATION

充电电池Rechargeable battery	2200MA/H3.7V
充电器工作电压 Charger working voltage	AC110-220V 50-60Hz
波长Wavelength	420-480mm
光强度Light intensity	1200mw/cm ² -1500mw/cm ²
重量Weight	0.865kg
包装规格Packaging Specifications	7.2x5.5x8.6cm



牙龈尖切断器
Gutta Percha Cutter
20-04

产品规格 SPECIFICATION

手柄的规格尺寸 The handle specifications	长度：126毫米； 直径：19毫米 Length:126mm; diameter:19mm
电源功率 Power supply	230伏/50赫兹，或115伏/60赫兹 230V/50Hz, or 115V/60Hz
温度 Temperature	工作温度：0°C~+40°C 储藏温度：-10°C~+60°C Operating temperature: 0°C~+40°C Storage temperature: -10°C~+60°C



8mm
黑体导光棒无金属头
20-05



10*15mm
直径10mm，嵌入深度15mm
20-06



12*15mm
直径12mm，嵌入深度15mm
20-07



14*15mm
直径14mm，嵌入深度15mm
20-08



台式喷砂机
Air Prophy
20-09



喷砂枪
Air Prophy
20-10



托槽喷砂机
Bracket Sandblasting Machine
20-11



头灯放大镜
Headband Dental Loupes With Light
21-01



头戴式放大镜
Dental Loupes
21-02



头戴式放大镜
Dental Loupes
21-03



头戴式头灯 (长款/短款)
Headband Dental Light
21-04



眼镜式带灯放大镜
Dental Loupes With Light
21-05



高级头灯放大镜
Top Grade Headband Dental Loupes with Light
21-06



22-01

产品规格 SPECIFICATION

额定电压Rated voltage	AC90~240V 50Hz~60Hz
输入功率Input power	≤50VA
熔断器 Fuse	F3AL250V
灯泡功率Bulb power	LED 3W×12
色温Color temperature	5500±500K
灯头直径 The straight length of the lamp holder	200mm
灯泡寿命Lamp life	50000h
工作距离Working distance	700mm
中心照度Center Illumination	≥40000Lux
净重 Net weight	7.5KG
包装尺寸Packing size	1040×335×230mm
包装材质Packing material	5瓦楞 纸箱5 corrugated carton

产品规格 SPECIFICATION

额定电压Rated voltage	AC90~240V 50Hz~60Hz
输入功率Input power	≤50VA
灯泡功率Bulb power	LED 3W×12
色温Color temperature	5500±500K
灯头直径 The straight length of the lamp holder	200mm
灯泡寿命Lamp life	50000h
中心照度Center Illumination	≥40000Lux(700mm处)
旋转半径Rotation radius	1440mm
净重 Net weight	6KG
包装尺寸Packing size	980×440×170mm
包装材质Packing material	5瓦楞纸箱5 corrugated carton



22-02

产品规格 SPECIFICATION

额定电压Rated voltage	AC90~240V 50Hz~60Hz
灯泡功率Bulb power	LED 3W×36
色温Color temperature	4500±500K
灯头直径 The straight length of the lamp holder	500mm
灯泡寿命Lamp life	50000h
中心照度Center Illumination	> 65000Lux(1m处)
光斑最小直径Minimum diameter of light spot	≤120
旋转半径Rotation radius	1440mm
净重 Net weight	35kg
包装尺寸Packing size	1060×600×390mm
包装材质Packing material	复合木箱wooden-box



22-03



LED射灯
LED Reflector Lamp
型号Mode: LA-R5

23-01



方形LED射灯
Square Reflector Lamp
型号Mode: LA-R6

23-02



四珠LED灯
Dental LED Lamp
型号Mode: LA-41

23-03



经典款卤素灯
Dental Halogen Lamp
型号Mode: LA-H1

23-04



四珠LED灯
Dental LED Lamp
型号Mode: LA-42

23-05



五珠LED灯
Five beads LED Lamp
型号Mode: LA-51

23-06



六珠LED灯
Six beads LED Lamp
型号Mode: LA-64

23-07



方形十二珠LED灯
Square twelve beads LED lamp
型号Mode: LA-12

23-08

产品规格 SPECIFICATION

项目/型号	LA-R5	LA-R6	LA-41	LA-H1	LA-42	LA-51	LA-64	LA-12
电压 Power supply	DC/AC/12-24V	DC/AC/12-24V	AC24V	110V-220V 转(tum)12V-24V	110V-220V 转(tum)12V-24V	AC12-24V	10V-30V AC/ DC	DC/AC/12-24V
频率 Frequency	-	-	-	-	-	50/60Hz	-	-
功率 Power consumption	5VA	7VA	13W	30W	30W	20W	22W	23VA
照度 Light intensity	6000-21000Lux	7000-23000Lux	8000-22000Lux	5000-40000Lux	5000-40000Lux	8000-20000Lux	20000LUX-45000LUX(可调)	7000-30000Lux
色温 Colour temperature	5000	5000	6000-6500K	4500-6500K	4500k-6000k	3000K-4500K	3200K-4500K(可调)	3000-4500
显色指数 CRI	>85	>90	85%	-	-	85%	大于等于90%	>90
无影效果 Shadow(solution)	-	-	8-16mm 椭圆	-	-	<10mm	-	-
光斑大小 Dimension of patten	L160×W80(mm)	L160×W80(mm)	-	-	-	L70×W140(mm)	-	L160×W80(mm)
对眼睛的照明 Eye intensity	<100Lux	<100Lux	<200Lux	-	-	<200Lux	-	<100lux
感应范围 Iteraction range	5CM	5CM	5CM以内	-	-	10-100mm	-	5CM
净重 Not weight	1.1kg	1.1kg	1.3kg	0.9kg	-	1.5kg	1.45kg	1.3kg

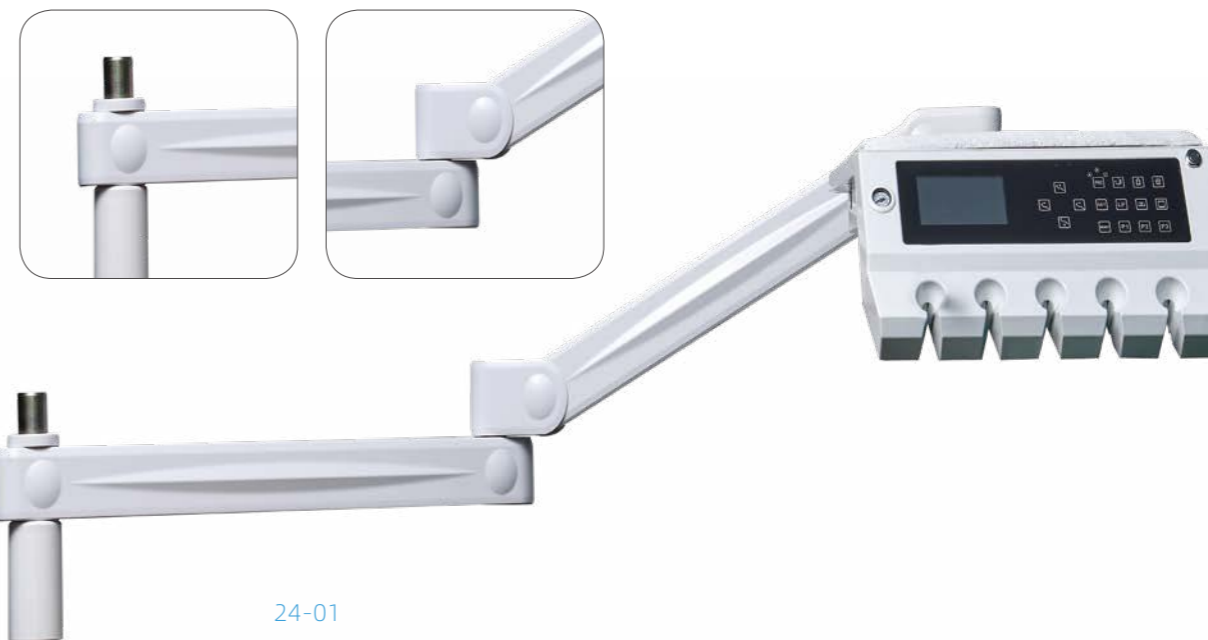
BALANCE ARM SERIES
平衡臂

24-01

产品规格 SPECIFICATION

拼装后的总长Total length after assembly	150cm
平衡臂尺寸Balance arm size	85×6×7.5cm
转臂尺寸Rotating Arm	78.5×7×7.5cm
(长×宽×高) 单位: cm	工具盘可以称重8公斤
外接口直径Outer interface diameter	50mm
行程夹角Angle	60°

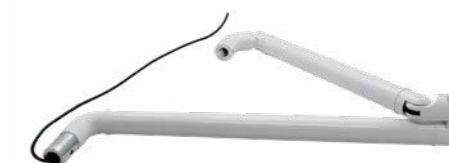

24-02

常规款平衡臂
Regular Balance Arm

24-03

圆形灯臂
Round Lamp Arm



DOCTOR CHAIR

医师座椅



25-01



25-02



25-03



25-04



PU皮座垫颜色
PU leather seat cushion color
25-05



气弹簧 (银色/黑色)
Gas Spring (Silver/Black)
25-06



国产座椅脚轮
Domestic Chair Wheels
25-07



进口座椅脚轮
Import Chair Wheels
25-08



金属五星脚
Metal Chair Foot
25-09

DENTAL CHAIR COVERS

牙椅椅套

温馨提示: 适用于任何牙椅, 可订制尺寸。
Tips: Suitable for any dental chair, can be customized size



脚垫
Foot Mat

26-02

26-01

效果图
Effect Diagram



枣红色CW1



大红色CW2



橘黄色CW3



柠檬黄CW4



彩金色CW5



苹果色CW6



湖绿色CW7



天蓝色CW8



彩兰色CW9



黑色CW10



玫红色CH1



橘色CH2



紫色CH3



柠檬黄CH4



苹果绿CH5



绿色CH6



天蓝色CH7



彩兰色CH8



黑色CH9

防水布 WATERPROOF

品名	豪华防水免洗型牙椅四件套
材质	防水弹性柔软布料(纵横双向弹力布)
组件	坐垫+头枕+靠背+医生坐垫
工艺	进口双橡胶筋包边及双线车工(全包边)
净重	均值0.59kg

健康布 HEATHCLOTH

品名	豪华加厚型弹力牙椅四件套
材质	加厚弹性耐磨柔软布料(纵横双向弹力布)
组件	坐垫+头枕+靠背+医生坐垫
工艺	进口双橡胶筋包边及双线车工(全包边)
净重	均值0.54kg

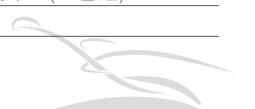



3 IN 1 TISSUE BOX 三合一附加台



型号: TB-2
27-01
外包装重量Packing size 20.4kg
外包装尺寸Gross weight :20X61X58cm

产品特点 FEATURES

- 1、塑料卡子升级为金属卡子，解决了以往塑料卡子容易断裂、杯子掉落的烦恼。
- 2、加厚半圆防止刮花，托盘固定更牢固。
- 3、内置纸巾盒节省空间，美观大方，再也不用担心纸巾盒容易破损的问题了。



1. The plastic clip is upgraded to metal clip, which solves the trouble that the plastic clip is easy to break and the cup falls.
2. Thicken the semicircle to prevent scratches, and the tray is fixed more firmly.
3. The built-in tissue box can save space and is beautiful and there is no need to worry about the tissue box breaking.

3 IN 1 TISSUE BOX 三合一附加台



型号Mode: TB-1
28-01



型号Mode: TB-1
28-02

TISSUE BOX/CUP HOLDER 座式纸巾盒 / 座式水桶杯



28-03
座式纸巾盒 蓝/白色可选
型号Mode: TTB-1



28-04
座式杯筒 蓝/白色可选
型号Mode: TC-1

TRAY 托盘

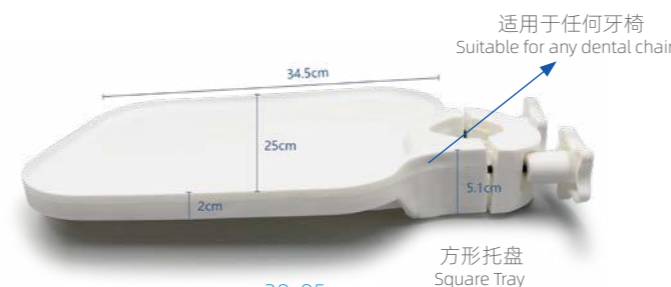

28-05
方形托盘
Square Tray
型号Mode: TT-1



28-06
弧形托盘
Curved Tray
型号Mode: TT-2

适用于任何牙椅
Suitable for any dental chair



STRONG AND WEAK SUCTION HANDLE

强弱吸收柄

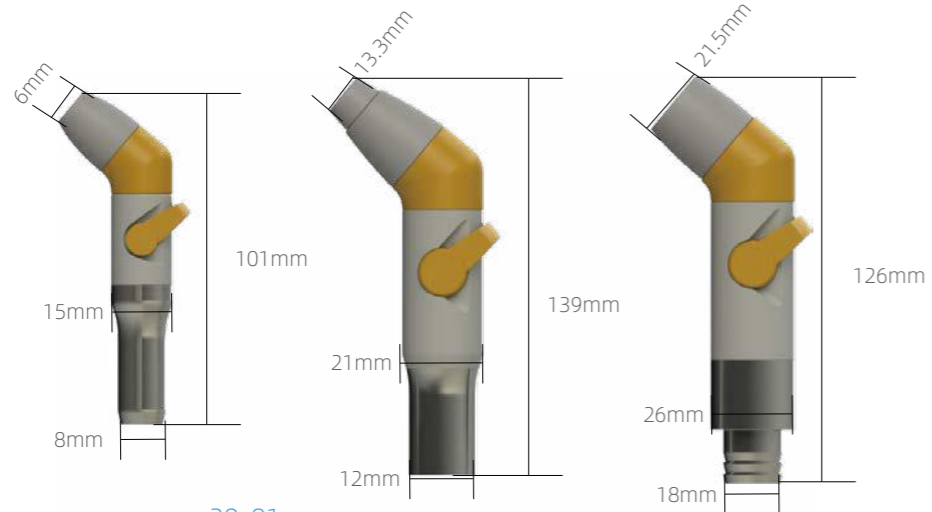

29-01

29-02

29-03

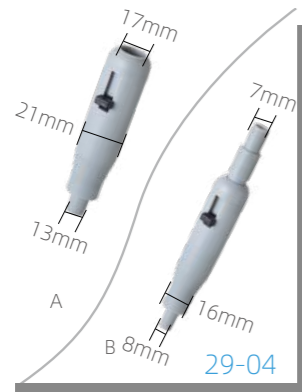

灰色塑料强弱吸手柄
(带开关)
Plastic Strong and Weak Suction

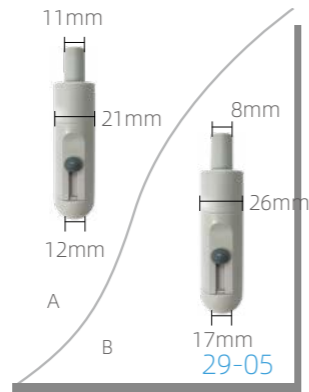

灰色塑料强弱吸手柄
(带开关)
Plastic Strong and Weak Suction

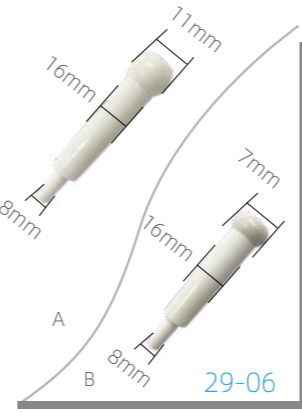

塑料强弱吸手柄
Plastic Strong and Weak Suction

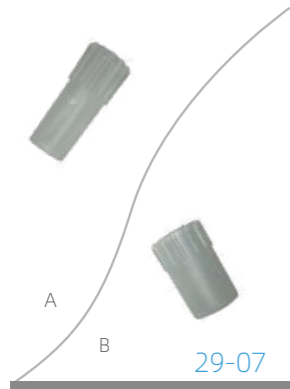

强弱吸转换头
Strong and Weak Suction Conversion Nozzle



弱吸硅胶头
Weak Suction Silicone Head Nozzle

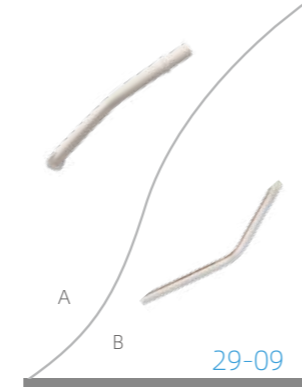

强弱吸管
Strong and Weak Suction Pipette

STRONG AND WEAK SUCTION

强弱吸

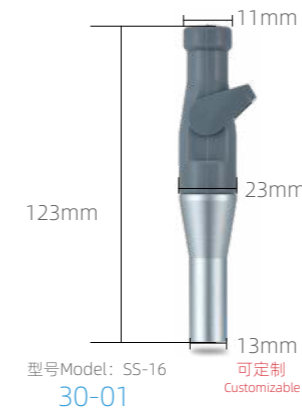

型号Model: SS-16
30-01

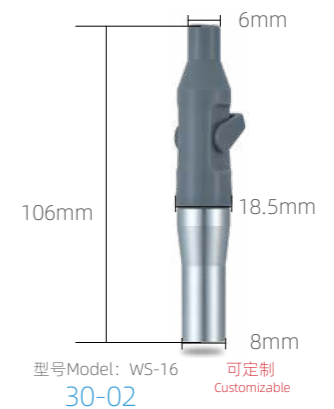

型号Model: WS-16
30-02

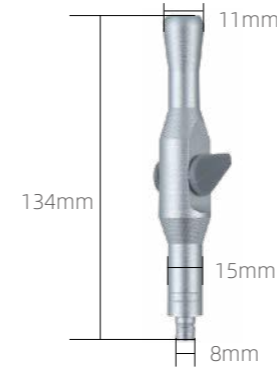

连体式强吸手柄
Strong Suction
(one-piece)
30-03

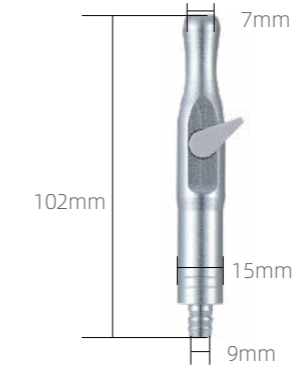

连体式弱吸手柄
Weak Suction
(one-piece)
30-04

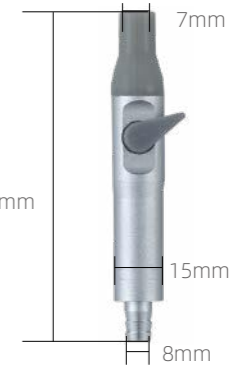

弱吸手柄(硅胶头)
Weak Suction
(silicone nozzle)
30-05



分体式弱吸手柄
Weak Suction
(split type)
30-06

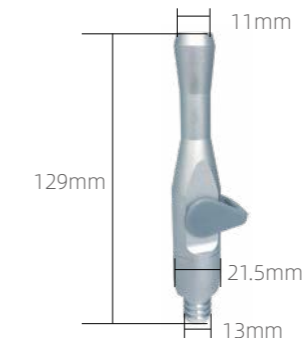

分体式强吸手柄
Strong Suction
(split type)
30-07

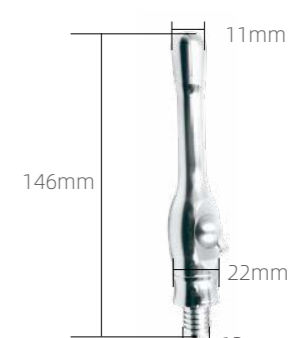

强吸手柄
Strong Suction
30-08

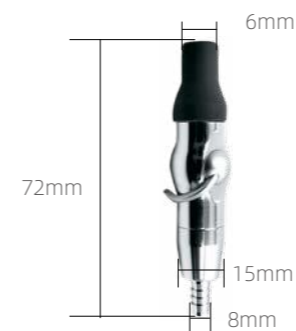

弱吸手柄
Weak Suction
30-09



铝强吸
Aluminum strong suction
30-10

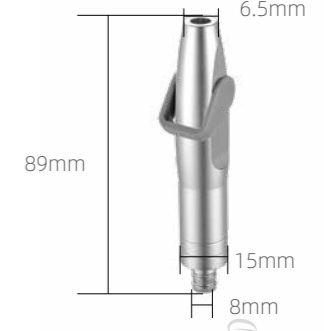

铝弱吸
Aluminum weak suction
30-11



型号Model: FC-15

两孔圆形脚踏开关
2 Holes Foot Control
31-01



型号Model: FC-15

四孔圆形脚踏开关
4 Holes Foot Control
31-02



型号Model: FC-20

四孔圆形脚踏开关
4 Holes Foot Control
31-03



型号Model: FC-24

圆形脚踏开关
New Foot Control
31-04



型号Model: FC-21

斜式圆形脚踏开关
New Foot Control
31-05



型号Model: FC-17

多功能脚踏开关 I
Multi-function Foot Control
(electronic control)
31-06



型号Model: FC-16

多功能脚踏开关 II
Multi-function Foot Control
(air control)
31-07



型号Model: FC-19

多功能脚踏开关 III
Multi-function Foot Control
(electronic control)
31-08



型号Model: FC-18

多功能脚踏开关 IV
Multi-function Foot Control
31-09



型号Model: FC-23

多功能脚踏开关 V
New Multi-function foot control
31-10



型号Model: FC-22

多功能脚踏开关 VI
New Multi-function foot control
31-11



多功能脚踏球
Foot Control Ball
31-12



牙椅上下电机
Dental Chair Motor
32-01



牙椅控制系统
Dental Chair Control System
32-02



工具盘
Tool Tray
32-03



副控盒 I 型
Assistent Control Box
32-04



副控盒 II 型
Assistent Control Box
32-05



副控盒 III 型
Assistent Control Box
32-06



五联大挂架
Handpiece Holder
32-07



五联小挂架
Handpiece Holder
32-08



单联白色小挂架盒
Single Holder
32-09



美式小挂架
American Style Holder
32-10



四位管座 (大/小)
Tube Holder (L)
32-11



二位管座 (大/小)
Tube Holder (L)
32-12



玻璃痰盂
Glass Spittoon
32-13



玻璃痰盂
Glass Spittoon
32-14



陶瓷痰盂
Ceramic Spittoon
32-15



密胺痰盂
Melamine Spittoon
32-16

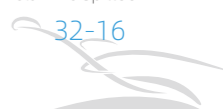



三联膜片阀
Triple Diaphragm Valve



四联膜片阀
Quadruple Diaphragm Valve



六角压水阀
Pressure Valve

直径d: 27mm d: 22mm

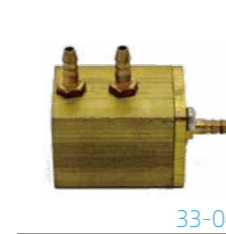

方形压水阀 (三接咀)
Pressure Valve

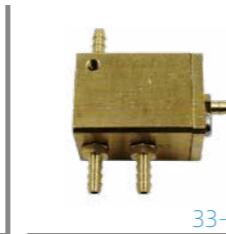

方形压水阀 (四接咀)
Pressure Valve



F型水调节阀3/5mm
F Type Regularion Vale



T型水调节阀3/5mm
T Type Regularion Vale



方形挂架阀 (常开)
Hanging Valve (Open)

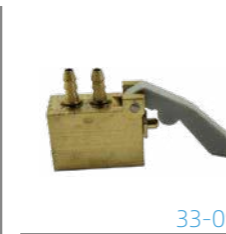

方形挂架阀 (常闭)
Hanging Valve (Close)



常闭挂架阀
Normal Close Hanging Valve



常开挂架阀
Normal Open Hanging Valve



大常闭挂架阀
Normal Close Hanging Valve(L)



大常开挂架阀
Normal Open Hanging Valve(L)



双防回吸快接头
Water Air Quick Connector



气锁开关 (六角)
Air Switch



气锁开关 (圆形)
Air Switch



单向阀
One Way Valve



气控电开关
Electric Valve



手机转换接头 二转四
Handpiece Coupler 2to4/4to2



手机转换接头 四转二
Handpiece Coupler 2to4/4to2



2孔手机螺旋接头 (四件套)
2 Holes Connector



4孔手机螺旋接头 (四件套)
4 Holes Connector



牙椅电磁阀
Dental Unit Solenoid Valve

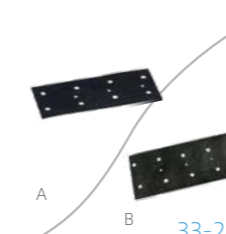

三联/四联膜片
Membrane



六角压水阀膜片
Pressure Valve Membrane

直径d: 27mm

直径d: 22mm



强吸阀
Strong Suction Valve



弱吸阀
Weak Suction Valve



T型总气开关 (3mm/5mm)
Main Air Switch(T)

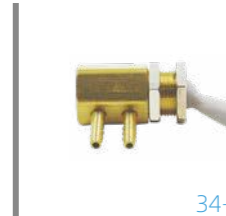

F型总气开关 (3mm/5mm)
Main Air Switch(F)

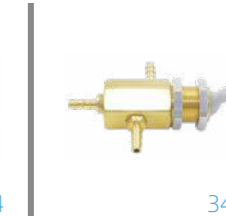

拨动式水源转换开关
(3mm/5mm)
Water Exchange Switch

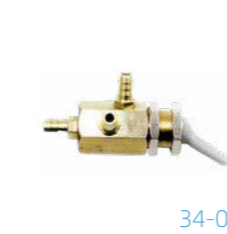

拨动式水源转换开关
(3mm/5mm)

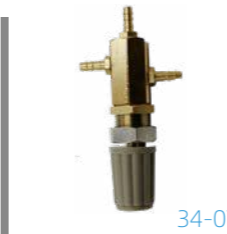

旋转式水源转换开关
Water Exchange Switch
New Water Exchange Switch



推拉式水源转换开关
Water Exchange Switch

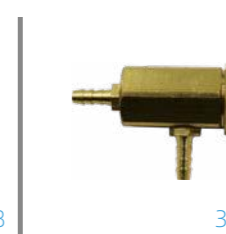

简易减压阀
Simple Pressure Reducing Valve

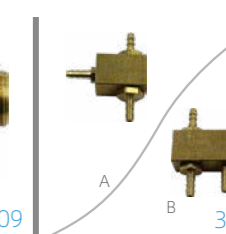

换向阀 (二/三位)
Commutator



气刹阀
Air Brake



两孔圆形脚踏阀
Foot Control Valve

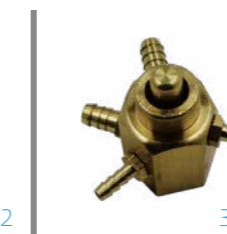

四孔圆形脚踏阀
Foot Control Valve



多功能脚踏阀 (3/5mm)
Multi-function Foot Control Valve



吹屑阀
Blowing Debris Valve



箱体集成阀(一体式)
Integrated Valve



箱体集成阀(18接咀)
Integrated Valve

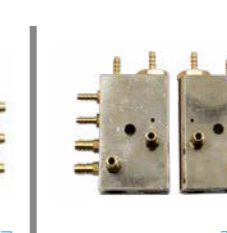

箱体集成阀(分体式左/右)
Integrated Valve



集成块
Integrated Valve

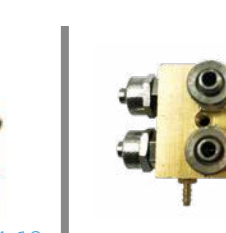

二位控制阀
Control Valve



铜直通 (接咀尺寸可选)
Metal Joint

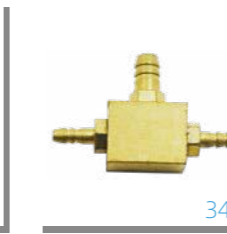

铜三通 (接咀尺寸可选)
Metal Joint

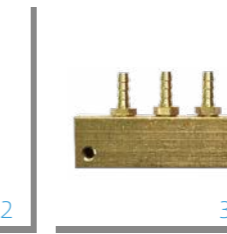

铜四通
Metal Joint



直角接头
Conector



快拧接头 (尺寸可选)
Quick Twist Connector





35-01 四孔手机管 4 Holes Handpiece Tubing	35-02 进口四孔手机管 4 Holes Handpiece Tubing (Import)	35-03 四孔并联手机管 4 Holes Handpiece Tubing (in parallel)	35-04 两孔手机管 2 Holes Handpiece Tubing
35-05 两孔螺旋手机管 2holes handpiece tubing (spiral)	35-06 光纤手机管国产 Fiber Optic Handpiece Tubing	35-07 光纤手机管进口 Fiber Optic Handpiece Tubing (Import)	35-08 三用枪直管 Syringe Tubing
35-09 三用枪螺旋管 Syringe Tubing	35-10 强吸管 strong suction tubing	35-11 弱吸管 weak suction tubing	35-12 四孔脚踏管 (并联) 4 Holes Foot Control Tubing
35-13 四孔脚踏管 (分体式) 4 Holes Foot Control Tubing	35-14 二孔脚踏管 2 Holes Foot Control Tubing	35-15 抽吸管 (规格可选) Suction Pipe (optional specifications)	35-16 地箱波纹管 Floor Box Pipe
35-17 水气管透明/蓝色 (尺寸可选) Tubing	35-18 光纤手机盒 (国产) Fiber Box	35-19 光纤手机盒 (国产) Fiber Box	35-20 光纤手机盒 (进口) Fiber Box(import)

36-01 热水器 Water heater	36-02 热水器 Water Heater	36-03 方形气压表 Square Pressure Meter	36-04 圆形气压表 (大/小) Round Pressure Meter
36-05 空气减压阀 Air Reducer	36-06 过滤器 Filter	36-07 变压器80W/200W Transformer	36-08 冲供水管/管座 Flush and Supply Water Tube
36-09 铜水过滤器 Water Filter	36-10 塑料水过滤器 Plastic Water Filter	36-11 强弱吸过滤器 Strong and Weak Suction Filter	36-12 强吸消声器 Strong Suction Silencer
36-13 痰盂过滤网 (长/短款) Spittoon Filter	36-14 痰盂漏斗四件套 (直式/横式) Spittoon Funnel 4 set	36-15 下水三通/多通 Adaptor	36-16 透明储水瓶 (不带盖) Storage Bottle
36-17 白色储水瓶600/1000/1500ML (不带盖) Storage Bottle	36-18 储水瓶盖 Bottle Cover	36-19 回气瓶 Air Bottle	36-20 手机管装饰套 Handpiece Tube Cover
36-21 小观片灯 Film Viewer	36-22 全景观片灯 Ponorama Film Viewer	36-23 镜片 (方形/小圆) Glass Reflector (square/small round)	36-24 大圆镜片 Glass Reflector (round)



ROOT CANAL TREATMENT SERIES

根管治疗系列

产品特点 FEATURES

1. 静音减速箱采用整体进口，有效降低噪音。
2. 智能一体更安全第三代根管治疗技术，与根测仪智能联机，边测边扩进入时智能启动，接近物理性根管口智能减速并反转，实时监测更安全。
3. 1:1一体式机头，可330度旋转，满足各种角度要求。三组轴承传动，有效降低阻力，输出更稳定，电池续航能力更长。
4. 所有参数可调，还有内置锉系统，9档记忆，同时配备主流品牌锉针系统车，使用更轻松。
5. 纤细机身，舒适手感，集十八般武艺于一身。小身板大容量，2000毫安大电池，彩色屏幕高分辨率，最新充电方案安全高效。

1. Imported quiet gearbox effectively reduces noise.
2. Smarter and safer Because of the third generation of root canal treatment technology, it will intelligently connect with apex locator, measuring and expanding at the same time; automatically start when enters root canals; slow down and reverse when gets close to the physical root canal spot; be safer with real-time monitoring system.
3. Adjustable contra-angle
 - ① 1:1 one-piece contra-angle can be rotated 330°, meeting various angle requirements;
 - ② Three sets of bearing transmissions, reduce resistance effectively, with more stable output and longer battery life.
4. Built-in files system
 - ① All parameters can be set equipped built-in name brand files system;
 - ② 9-program memory is easy to use.
5. Perfectly design
 - ① Slim body with 2000 mA battery, comfortable touch with high resolution color screen;
 - ② New charging method is safe and efficient.



37-01



37-02

产品规格 SPECIFICATION

项目Item	信息Information
型号Model	V-PEX
尺寸Dimensions	205毫米x185毫米50毫米±2毫米 (包装尺寸)
重量Weight	585g±10% (包装)
电池Power supply	锂电池ICR14500 3.7V, 800mAh, ±10%
适配器输入Charger power supply	单相, AC 100-240 V, ±10%
适配器输出Charger nominal power input	5VA
电源额定频率Degree of Protection	50/60Hz, ±10%
防电击类型分类Electrical safety class	II类, 内部电源设备
应用部分类型Applied part	B
使用环境条件Ambient conditions	环境温度: 5°C~40°C Ambient temperature: 10°C/40°C 相对湿度: <80% Relative humidity: <80%; non-condensing at 0°C 工作海拔: <2000m Operating altitude <2000 m above sea level
运输和存储条件Transport and storage conditions	环境温度: -20°C~+55°C Ambient temperature: -20°C/+55°C 相对湿度: 20%~80% Relative humidity: 20%-80% 大气压力: 70kPa~106 kPa Atmospheric pressure: 50kPa~106kPa

HIGH-SPEED HANDPIECE SERIES

高速手机系列

产品特点 FEATURES

特殊卫生机头结构，防止杂质进入机头。采用进口陶瓷轴承。
手机机头采用CNC一体成型。
避免交叉感染。

产品规格 SPECIFICATION

手机接口处气压 Air pressure at the connector	0.25~0.27Mpa (4 holes) 0.20~0.22Mpa (2 holes)
转速Rotation speed	≥300, 000rpm
适用车针 Bur applicable	φ1.59mm~φ1.6mm ×21mm~23mm (直径×长度)
噪音Noise	≤68dB
按压式高速手机单点喷水 Chuck type: Push button	



38-01

产品特点 FEATURES

手机为单点雾化，手机出水孔与出气孔均采用精密电火花加工雾化效果更好，不易堵塞。
特殊卫生机头结构，防止杂质进入机头。高性能陶瓷轴承，低噪音，低震动，寿命长。
车针锁紧装置，最精确的车针锁紧和旋转驱动技术，创造出最佳平稳无顺动的效果。

产品规格 SPECIFICATION

手机接口处气压 Air pressure at the connector	0.25~0.27Mpa (4 holes) 0.20~0.22Mpa (2 holes)
转速Rotation speed	≥300, 000rpm
适用车针 Bur applicable	φ1.59mm~φ1.6mm ×21mm~23mm (直径×长度)
噪音Noise	≤68dB
取针式高速手机单点喷水 Chuck type: Key type	



38-03



卸针器
Needle Unloader



后盖
Needle Unloader



38-02



38-04



轴
Shaft



机芯
Cartridge

产品特点 FEATURES

传统单点雾化更有效的冷却方式。
优质陶瓷轴承性能更好，寿命更长。
弹簧式按压轴轻松更换车针。
质量稳定，使用寿命长，耐高温消毒。

产品规格 SPECIFICATION

手机接口处气压 Air pressure at the connector	0.25~0.27Mpa (4 holes) 0.20~0.22Mpa (2 holes)
转速Rotation speed	≥300, 000rpm
适用车针Bur applicable	φ1.59mm~φ1.6mm ×21mm~23mm (直径×长度)
噪音Noise	≤68dB
按压式高速手机单点喷水 Chuck type: Push button	

产品特点 FEATURES

手机为单点喷水，手机出水孔与出气孔均采用精密电火花加工雾化效果更好，不易堵塞。
筒夹式机芯，更能保证机芯机芯上下轴承同心度。
机芯维护简单，可多个机芯交替使用延长手机使用寿命。
大扭矩，劲力足。机芯与NSK通用。

产品规格 SPECIFICATION

手机接口处气压 Air pressure at the connector	0.25~0.27Mpa (4 holes) 0.20~0.22Mpa (2 holes)
转速Rotation speed	≥300, 000rpm
适用车针 Bur applicable	φ1.59mm~φ1.6mm ×21mm~23mm (直径×长度)
噪音Noise	≤68dB
按压式高速手机单点喷水 Chuck type: Key type	



LOW-SPEED HANDPIECE SERIES

低速手机系列



39-01



39-02



39-03

产品特点 FEATURES

新款马达比旧款马达长度大约短25%-30%，重量比较轻，微型的尺寸带来更强大的扭力，此设计更加符合人体工程学，增加了手部舒适度和精细度，提高了使用平衡度，可承受最高135度高压灭菌。

The length of the new motor is 25%-30% shorter than the old motor, and the weight is lighter. The miniature size brings stronger torque. This design is more ergonomic, enhances the comfort and accuracy of the hand, and improves the balance, can withstand 135° high temperature sterilization.



39-04



39-05



39-06

产品特点 FEATURES

升级版全新卡环，无须担心高温高压消毒，经久耐用，寿命长。
金属磨砂防滑耐脏，自然曲线，符合人体工程学。
卡片锁针，设计稳固，进口不锈钢转动轴，适用寿命长。
马达，直机，弯机采用E型接口，与其他品牌同类型手机通用。

Use a brand new snap ring, don't worry about high temperature and high pressure disinfection, durable and long service life. Matte metal appearance, non-slip and dirt-resistant, natural curve, ergonomic; card lock pin, stable design, imported stainless steel rotating shaft, extended service life. Motors, straight motor, and bend motor all use E-type interfaces, which are common to other handpiece of the same type.

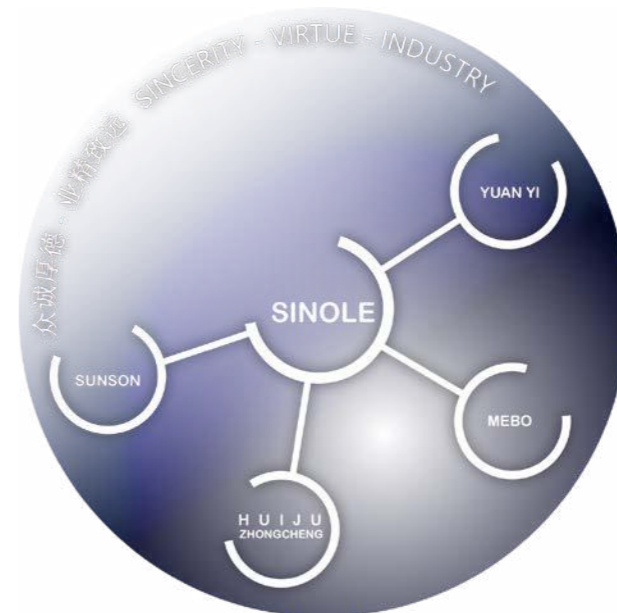

公司创立 Company founded

2004年8月1日，韩宗明先生在佛山市成立了一家牙科器材公司，并将其命名为鑫诺尔。其理念是致力于口腔医疗器械制造，为人类口腔健康做出贡献！时至今日，鑫诺尔已经成为佛山口腔医疗器械产业领跑者。鑫诺尔在最初的目标就是在新的国内市场中保持竞争力，并在2013年进军国际市场，从而实现飞跃发展。

多年来，鑫诺尔始终秉承精于制造，技术为先的理念来研发产品，并成功推出多款市场受欢迎的产品。公司独有的牙椅枕头架和新型三用枪加工工艺一直广受好评。此外，鑫诺尔还推出一款高性能、低消耗全新牙科手机养护机。未来，鑫诺尔将继续开展新技术研究，推动产品研发、生产和销售。

On August 1, 2004, Mr. Han Zongming established a dental equipment manufacturing company and named it Sinole. Its philosophy is to devote itself to the manufacture of oral medical devices and contribute to human oral health! Today, Sinole has become a leader in the dental medical device industry in Foshan. Sinole's initial goal is to maintain competitiveness in the new domestic market, and to enter the international market in 2013, so as to achieve rapid development.

Over the years, Sinole has always been adhering to the concept of manufacturing excellence and technology first to develop products, and successfully launched a variety of products with strong market responses. The company's unique dental chair Headrest and new 3 way syringe processing technology has been widely praised. In addition, Sinole also launched a new high-performance, low-energy consumption dental handpiece lubrication machine. In the future, Sinole will continue to carry out new technology research and promote product development, production and sales.

双升创立于2017,主要生产电子科技产品

Sunson Technology was founded in 2017, mainly producing electronic technology products

元乙创立于2018, 主要从事五金加工制造与设计

Yuan Yi was founded in 2018, mainly engaged in hardware manufacturing and design

汇聚众诚创立于2019, 主要生产边柜, 组合柜

Founded in 2019, Huiju Zhongcheng mainly produces side cabinets and combination

美帛创立于2020, 主要生产牙椅布套, 医生护士制服

Mebo Fabric Founded in 2020, mainly produces dental chair covers, uniforms for doctors and nurses