

# Built for Battle® DD-6 SAFE

6" Double-Diaphragm Pump  
Sound Attenuated Fully Enclosed (SAFE)



A favorite among contractors and rental companies for its versatility. This hardworking pump moves air, water and solids. Plus, this high-volume pump is simple and easy to use, like all of the pumps in our Built for Battle line.

## Duty Points

Max Flow: 550 GPM/ 2081 LPM  
Max Head: 80 TDH/ 24.38 m  
Max Suction Lift: 28' ft/ 8.53 m  
Solid Handling: 4"/ 101.6 mm  
Max CFM: 60 CFM

## Market Segment

Construction  
Municipal: Waste Water  
Industrial  
Petrochemical  
Oil & Gas  
Mining  
Food Processing



Components of this product are protected by one or more patents. The protected components and the associated patent(s) are identified at: [www.msp-pumps.com](http://www.msp-pumps.com)

## Flow Chart

### Standard Features

- Sound Attenuated Fully Enclosed
- Camlock or Bauer Hose Fittings
- Lockable Fuel Cap
- Fuel Gauge
- Heavy Duty Lifting Bale
- 5,000 lbs. Front Jackstand
- Powder-Coated Frame
- DOT Trailer Lights
- High Volume Pump

- Highway Fenders
- Heavy Duty Battery and Cables
- Easy Access Cleanouts

### Options

- Skid Mounted
- AUTO Start Control Panel
- GPS Telematics
- Pushrod Protection Cover
- Electric-Driven Pump Packages Available

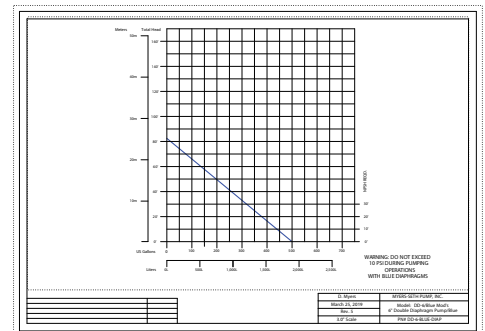

SOLD BY



info@aquosis.com  
1.877.907.7852



HERE FOR YOU  
904.389.6114



# Built for Battle® DD-6 SAFE

## Specifications

Engine		Frame	
Make/Model	HATZ 1090/EZ	Frame Construction	10" Square Steel Tubing
Horsepower	10.3 hp @2,000 rpm	Fuel Capacity	71 gal (246.05 L)
dBA Sound	68dB	Lifting Bale	Heavy Duty Single Point
Safety Shutdowns	Low Oil Pressure	Tie Downs	(4) Heavy Duty Tie Down Points
Engine Displacement	40.70 cu (0.667 L)	Height	64" (162.56 cm)
Engine Type	One Cylinder, Air-Cooled, Diesel	Width	74" (187.96 cm)
Daily Fuel Consumption	6 – 8 gal/day	Length	112" (284.48 cm)
Max Continuous Run Time	216 hrs (9 days)	Weight	2980 lbs (1352 kg)
Standard Equipment	Instrument Control Panel w/Hour Meter	Wheels & Tires	15" P205/75R15 Radial
		Axle Type	3,500 lbs Torflex

Pump			
Pump Housing	A-36 Steel	Max Operating Speed	60 rpm (Gearbox) 1800 rpm (Engine)
Pump Capacity Suction	Blue - 550 GPM @ 1800 rpm (2081 LPM)	Max Operating Temperature	160°F/71.11°C
Bursting Diaphragm Pressure	80 psi	Flapper Valves	3/8" Weighted, Full-Flow, Reinforced Rubber
Max Operating Diaphragm Pressure	10 psi	Max Suction Lift	Blue - 28' ft (8.53 m)
Max Head Pressure	80 TDH (24.38 m)	Air Handling	Blue – Max 60 CFM
		Suction & Discharge Valve Seats	Stainless Steel, 3/8" Plate
		Solid Handling	Blue - 4" (101.6 mm)

**Warning: Do not exceed 10 psi during pumping operations with Blue Diaphragms**

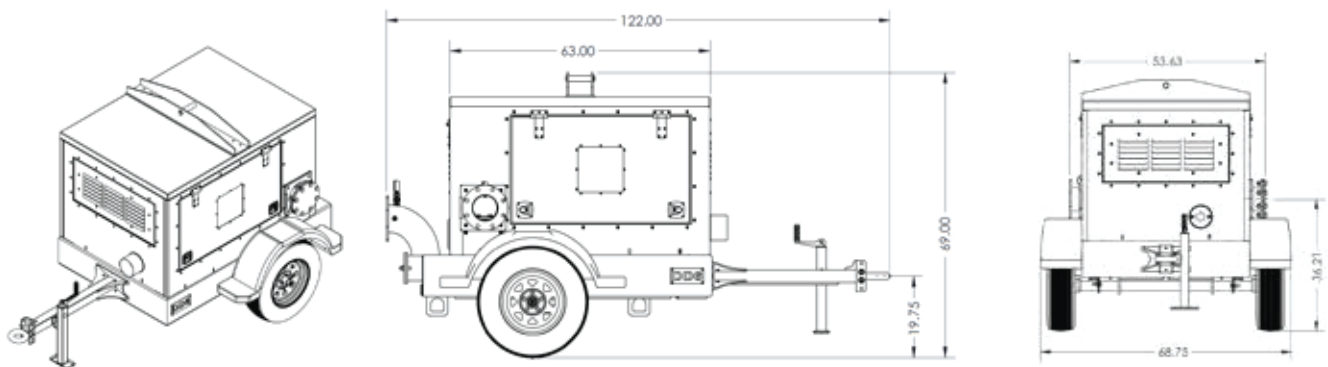

SOLD BY

Myers-Seth Pumps | [goodpeople@msp-pumps.com](mailto:goodpeople@msp-pumps.com) | 4611 Dignan



**AQUOSIS**  
FLUID SOLUTIONS

[info@aquosis.com](mailto:info@aquosis.com)  
1.877.907.7852