

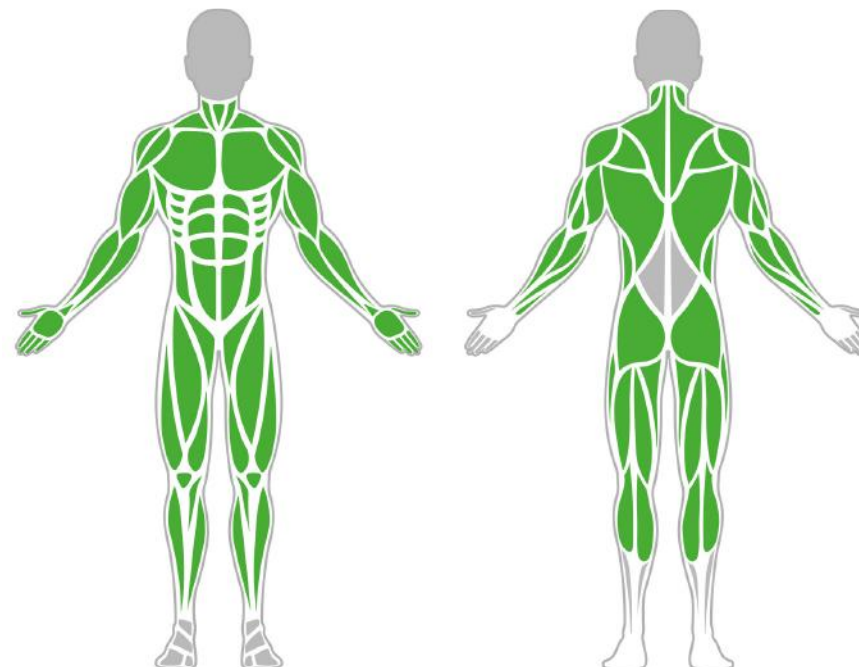

Muscle Groups Focus



Climbing Rope Frame

The climbing rope provides you with the opportunity of a full body workout with very simple equipment. It is extremely effective at conditioning and building endurance, an essential part of body weight training, An incredible tool for child physical development as well.

Attributes

Product code	1-1-020
Certificate	EN 16630, ASTM F3101
Age group	14 + years
Capacity	1 person
Max. weight load	218.26 lbs
Type	Cross Training
Difficulty level	Medium

Side View

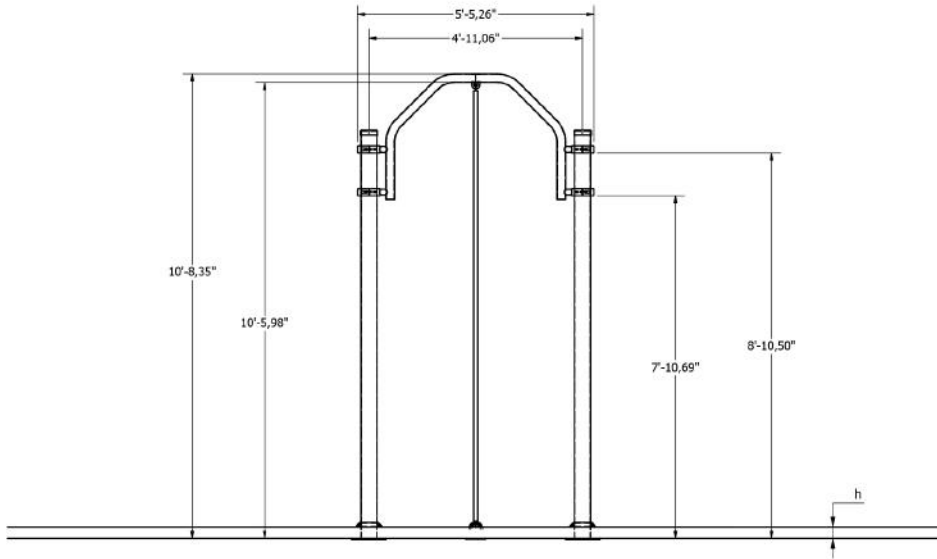

Plan View

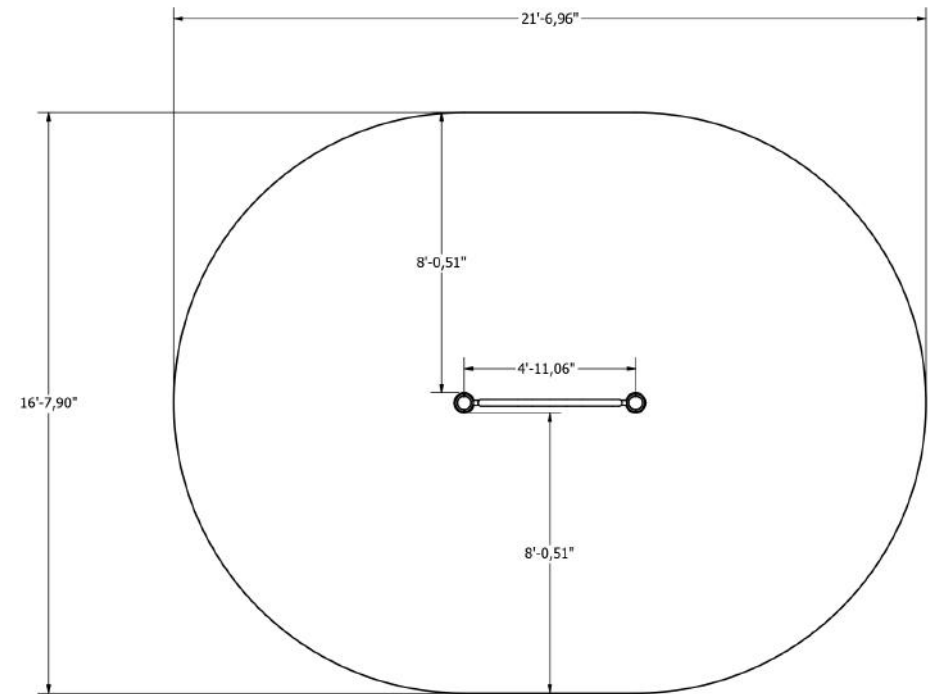

Installation information

Number of installers (concrete)	At least 2 people
Total installation time (concrete)	45-90 min.
Number of installers (equipment)	At least 2 people
Total installation time (equipment)	20-30 min.
Excavation volume	14,13 ft ³
Concrete volume	14,13 ft ³
Size of the base structure	2pc 19.69 x 19.69 x 31.5 „
Anchoring options	In-ground or surface
In combined structures, the volume of concrete required varies.	

Technical specification

Safety surface area	Around 2,45 ft radius
Net weight	68.34 lbs
Material	S235
Critic fall height	125.98"
Color options	
For more color options, discuss with your sales representative.	

Warranty

Structure	25 years
Steel	15 years
Paint	2 years
Plastic	5-10 years
Rubber	1-3 years
Moving parts	2 years
Detailed information in the warranty document	

Material specification

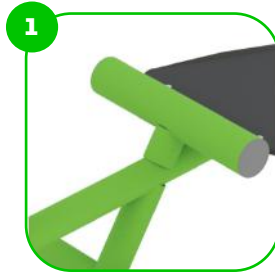

The element is made of high quality S235 steel, which has been cleaned via sandblasting. A corrosion resistant powder coating finish is then applied. Also available with galvanized surface for even greater protection and longevity!



The clamp system allows for easy assembly and extreme stability.



The ends of the bars and posts are sealed with injection-moulded plastic caps.

BESTSTRONG

 [bestrongworld](#)  [bestrongworld](#)  [usa.bestrong.com](#)  usa@bestrong.com

