

**HunterDouglas** 

Architectural

# SOLAR CONTROL

WOODEN SUNLOUVERS \_  
TILTING SUNLOUVERS \_  
LINEAR SUNLOUVERS \_ MESH  
SUNSCREENS \_ SCREEN PANELS \_  
FOLDING & SLIDING SHUTTERS \_  
FINISHINGS



# SOLAR CONTROL

**HunterDouglas**   
Architectural





Hunter Douglas is a global leader in architectural products. Our tradition of bringing innovative solutions to the market makes us the ideal company to provide a wide range of products for interiors and exteriors applications, suspended ceilings and sun control solutions. We are always seeking out, testing and developing new concepts and products that allow us to meet increasingly strict standards and have a positive influence in the world of design, architecture and sustainability in buildings. Starting from the specification, we work with architects, designers and builders to manage light, heat and acoustics. Our experience in personalization, manufacturing, installation and technical support allows us to offer excellent products with our signature design, performance and exceptional durability.

**Solar Control: Design, Functionality and Comfort.** Hunter Douglas gives architects the knowledge and experience necessary to integrate sun control systems into the design of their projects, collaborate on the improvement of the aesthetic of façades and provide excellent protection. Modern buildings have very effective insulation design and low heating needs. However, cooling mechanisms are often necessary to ensure that occupants are comfortable due to sun exposure. By integrating Hunter Douglas sun control solutions, architects can optimize energy efficiency and users' visual comfort.

## HUNTER DOUGLAS, A WORLD OF INNOVATION

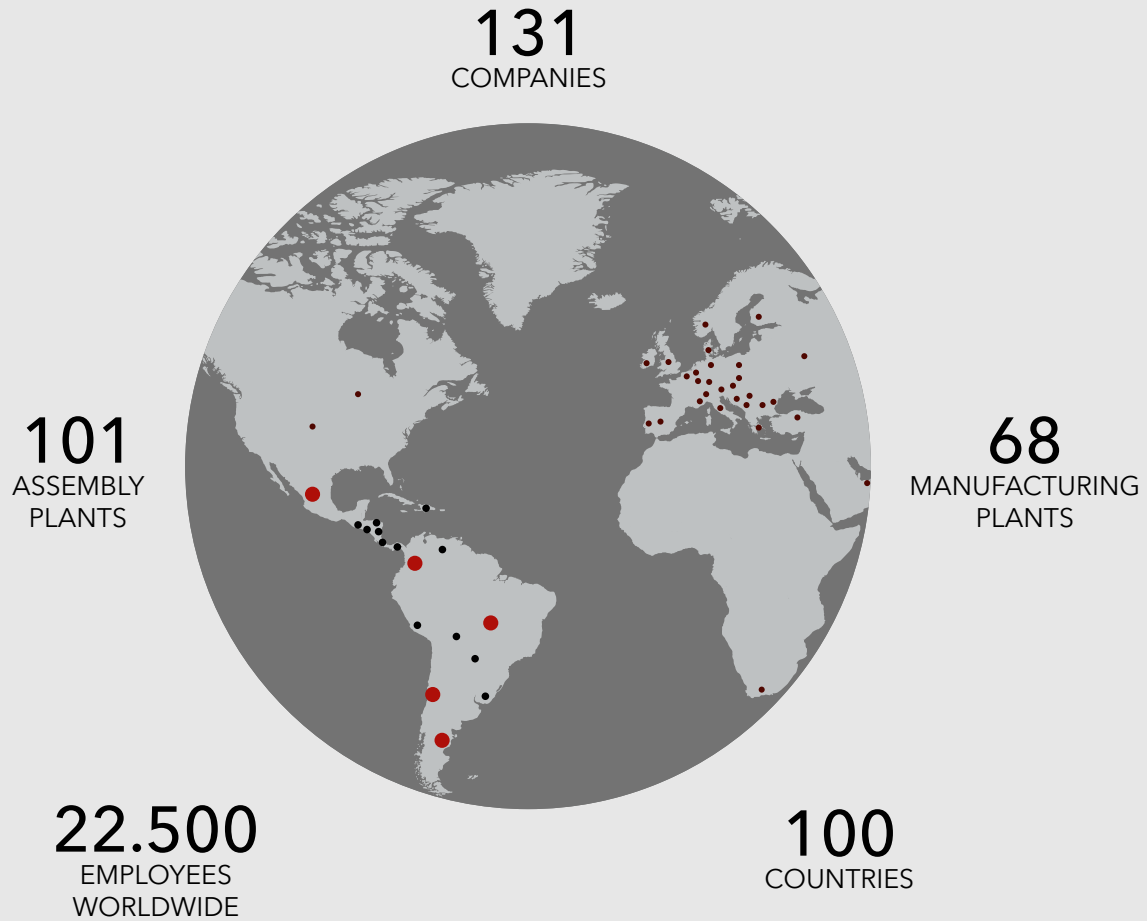

Hunter Douglas is a global leader in the manufacture of architectural products including innovative window treatments, sun control, wall panels, ceilings and façades. Some of our main products are listed below:

- Exterior roller blinds and fabric screen frames
- Exterior venetian blinds
- A wide range of shading systems for windows
- Automated and custom shading systems
- Suspended ceilings
- Wall cladding
- Terracotta NBK façades
- Metal Quadroclad façades
- Ultra flat façades

### HUNTER DOUGLAS' PRESENCE IN LATIN AMERICA

Hunter Douglas Operations in Latin America:

- Argentina- 22 years
- Brazil- 47 years
- Chile- 52 years
- Colombia- 58 years
- Mexico- 37 years

### HUNTER DOUGLAS LATIN AMERICA EXPORT DISTRIBUTION NETWORK

Bolivia, Costa Rica, the Dominican Republic, Guatemala, Honduras, Nicaragua, Panama, Paraguay, Peru, Uruguay, and Venezuela.



## OUR FOUNDING

Hunter Douglas developed as a result of its founders' work with recycled aluminum. In 1940, Henry Sonnenberg moved from The Netherlands to the United States, where he started the Douglas Machinery Corporation. A few years later, he began to work with Joe Hunter, who had recently invented a continuous machine for melting and laminating aluminum from scrap metal. This discovery led to the production of aluminum blinds.



## CEILING / ARCHITECTURAL PRODUCTS

Based on this unique continuous aluminum melting and lamination system, Henry and Joe became pioneers in the development of aluminum venetian blinds. Together, they created the Hunter Douglas Company as we know it today. In 1962, the company began to make linear metal ceilings, creating a standard system that has evolved and generated a full line of products for all sorts of projects.



## GLOBAL PRESENCE

A significant part of Hunter Douglas operations continue to be focused on aluminum recycling with a recycling plant, foundry and continuous caster in Rotterdam, The Netherlands. From there, the company operates manufacturing and distribution plants in over 100 countries with installations in thousands of projects around the world.

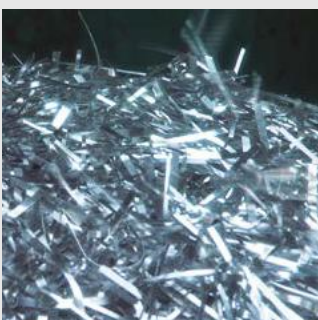

## SUSTAINABILITY

Hunter Douglas is on the cutting edge of the development of ideas for sustainable products. We seek to simplify assembly, improve production processes and waste disposal and reduce maintenance in our operations. We are also partners with organizations such as the U.S. Green Building Council and Green Building Initiative as part of our efforts to have a positive impact on all phases of the construction industry.

WOODEN SUNLOUVERS

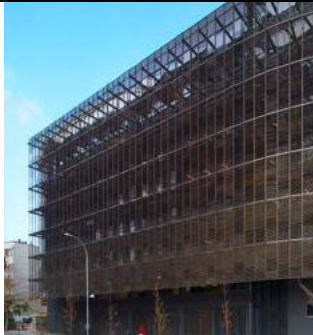

Woodbrise 66 - 100  
P. 12

MOVEABLE SUNLOUVERS

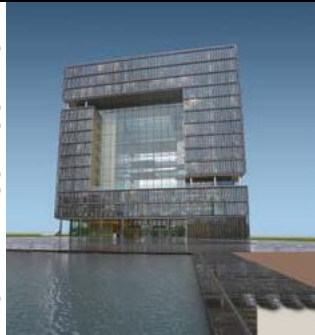

Aeroscreen Plus  
P. 22

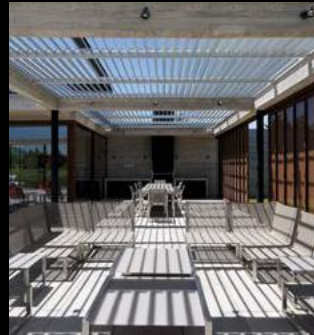

Aerowing  
P. 28



Metalbrise  
Pág. 32

LINEAR SUNLOUVERS



Celoscreen  
P. 62



Sunlines  
P. 66



Viewbreaker 30B - 50B - 50BD  
P. 70



Quadrobrise 32 X 32  
P. 74



Sunlouvers H2 - SL4  
P. 94



Sunscreen Flat  
P. 98



NBK  
P. 104

SCREEN PANELS



Screenpanel  
P. 132



Softwave 25 - 50  
P. 148



Quadrolines  
P. 152



GKD Screens  
P. 156

ROLLER SHADES, BLINDS & AWNINGS



80MM Exterior Blinds  
P. 190



Vertical Awnings  
P. 200



Aluminium Blinds  
P. 206



Roller Shades Quantum  
P. 210





Termobrise  
P. 38



Windscreen  
P. 42



Motorization  
P. 46

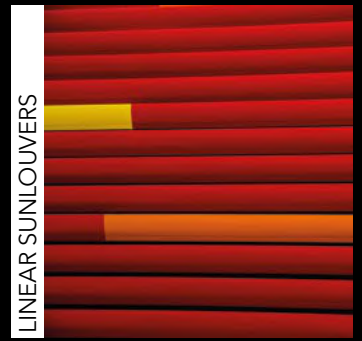

LINEAR SUNLOUVERS

Aerobrise | Quadrobrise  
P. 56



Tubrise  
P. 78

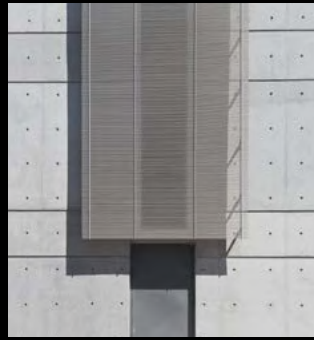

Minitubrise  
P. 82



Sulouver C  
P. 86



Sunlouver 70S  
P. 90

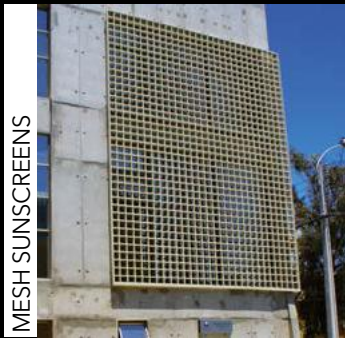

MESH SUNSCREENS

Brisolcell  
P. 112



Filigree  
P. 116

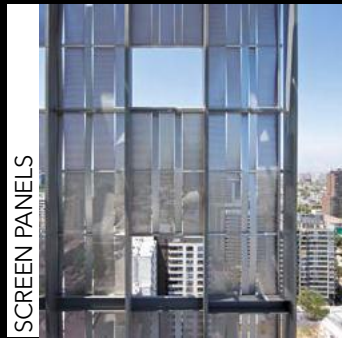

SCREEN PANELS

Stripweave  
P. 122



Stripscreen  
P. 128



Alusion  
P. 160



FOLDING & SLIDING SHUTTERS

Folding & Sliding Shutters  
P. 168



TexScreen  
P. 180



FINISHINGS

Paints  
P. 224



Woodgrains | Mineralgrains  
P. 228



Perforations  
P. 234

## SYMBOLS

---

Hunter Douglas has provided a series of icons that clearly represent the characteristics of each of the products included in this catalogue, providing essential information and making it easier to read the technical specifications.



MOTORIZED

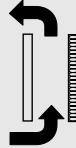

VENTILATED FAÇADE



ENERGY SAVINGS



WASHABLE



CONTRIBUTES LEED POINTS



RESISTANT TO HUMIDITY



SUN CONTROL



COLOR PALETTE



AVAILABILITY OF MATERIALS



RECYCLED

<b>SOLAR CONTROL</b>										
WOODBRISE 66 - 100	✓	✓	✓	✓			✓	✓	✓	✓
AEROSCREEN PLUS	✓	✓	✓	✓	✓		✓	✓	✓	✓
AEROWING	✓	✓	✓	✓			✓	✓	✓	✓
METALBRISE	✓	✓	✓	✓	✓		✓	✓	✓	✓
TERMOBRISE 150 - 335	✓	✓	✓	✓	✓		✓	✓	✓	✓
WINDSCREEN		✓	✓	✓			✓	✓	✓	✓
AEROBRISE 100 - 200		✓	✓	✓	✓		✓	✓	✓	✓
QUADROBRISE 25/50 - 25/75		✓	✓	✓	✓		✓	✓	✓	✓
CELOSCREEN		✓	✓	✓	✓		✓	✓	✓	✓
SUNLINES		✓	✓	✓	✓		✓	✓	✓	✓
SUNLOUVER 30B - 50B - 50BD		✓	✓	✓	✓		✓	✓	✓	✓
QUADROBRISE 32 X 32		✓	✓	✓	✓		✓	✓	✓	✓
TUBRISE		✓	✓	✓	✓		✓	✓	✓	✓
MINITUBRISE		✓	✓	✓	✓		✓	✓	✓	✓
C LATTICE		✓	✓	✓	✓		✓	✓	✓	✓
70 S LATTICE		✓	✓	✓	✓		✓	✓	✓	✓
84R - SL4 - H2 SHADE		✓	✓	✓	✓		✓	✓	✓	✓
FLAT SHADE		✓	✓	✓	✓		✓	✓	✓	✓
NBK - TERRART BAGUETTE		✓	✓	✓			✓	✓	✓	✓
BRISOLCELL		✓	✓	✓	✓		✓	✓	✓	✓
FILIGREE		✓	✓	✓	✓		✓	✓	✓	✓
STRIPWEAVE		✓	✓	✓	✓		✓	✓	✓	✓
STRIPSCREEN		✓	✓	✓	✓		✓	✓	✓	✓
SCREENPANEL		✓	✓	✓	✓	✓	✓	✓	✓	✓
SOFTWAVE 25 - 50		✓	✓	✓	✓	✓	✓	✓	✓	✓
QUADROLINES 30 X 15 - 15 X 10		✓	✓	✓	✓	✓	✓	✓	✓	✓
GKD SCREENS		✓	✓	✓	✓		✓	✓	✓	✓
ALUSION		✓	✓	✓		✓		✓		✓
FOLDING & SLIDING SHUTTERS	✓	✓	✓	✓	✓	✓	✓	✓	✓	✓
TEXSCREEN		✓	✓	✓			✓	✓	✓	✓
80MM EXTERIOR ALUMINIUM BLINDS	✓	✓	✓	✓		✓	✓	✓	✓	✓
VERTICAL AWNINGS	✓	✓	✓	✓	✓		✓	✓	✓	✓
PRECIOUS METALS	✓	✓	✓	✓					✓	✓
ROLLER QUANTUM CURTAIN	✓	✓	✓	✓	✓				✓	✓

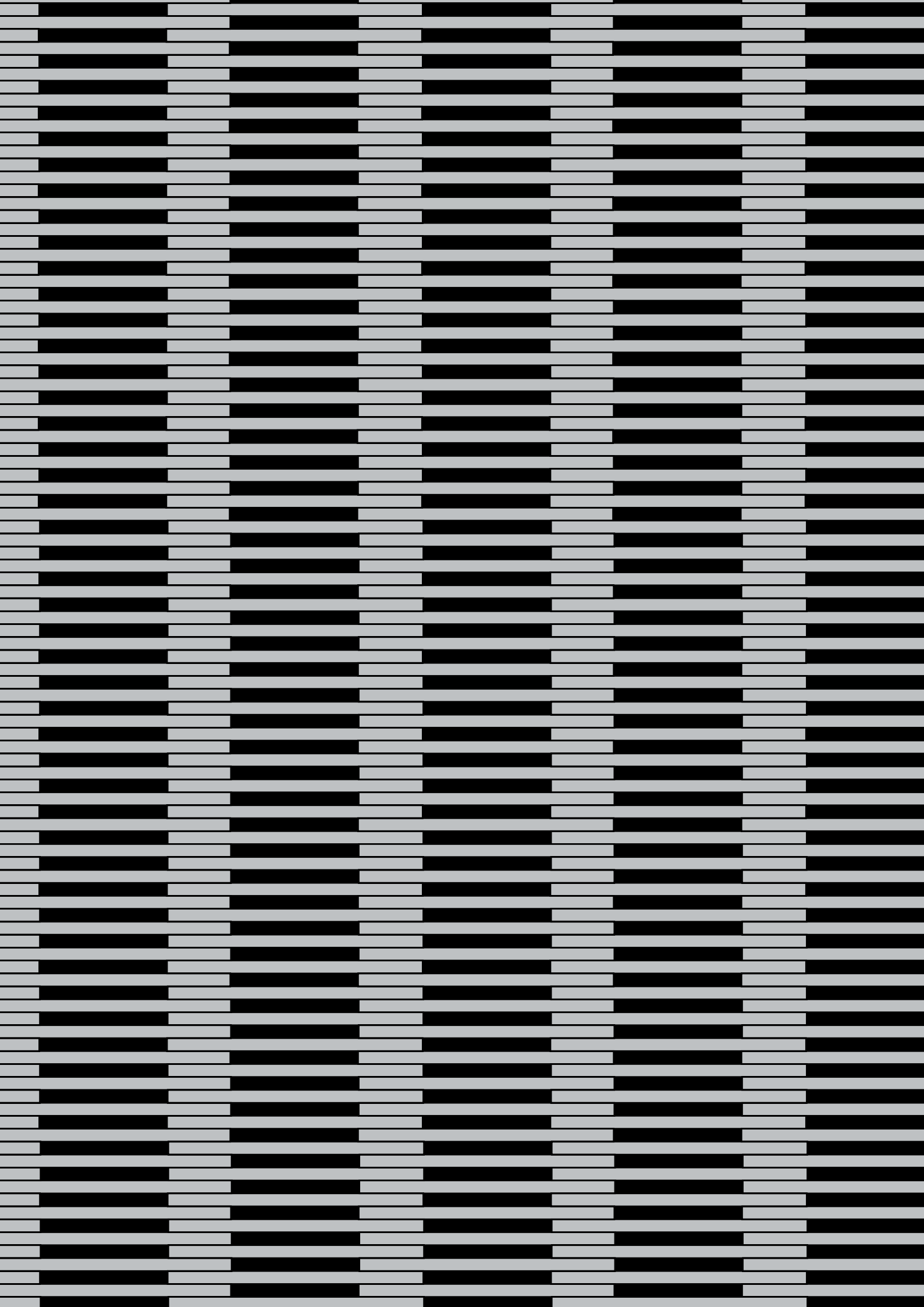

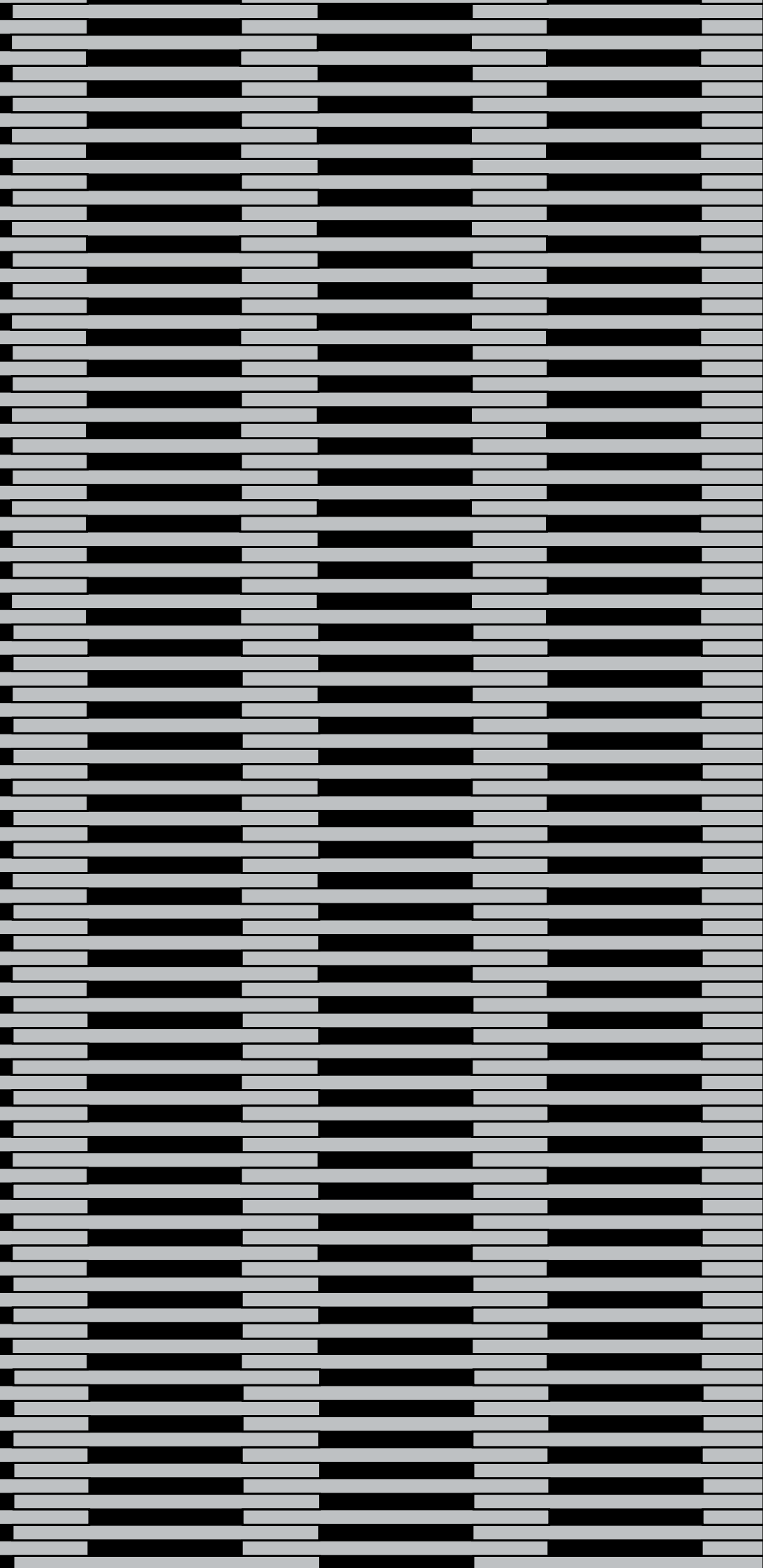

**WOODEN SUNSCREENS**

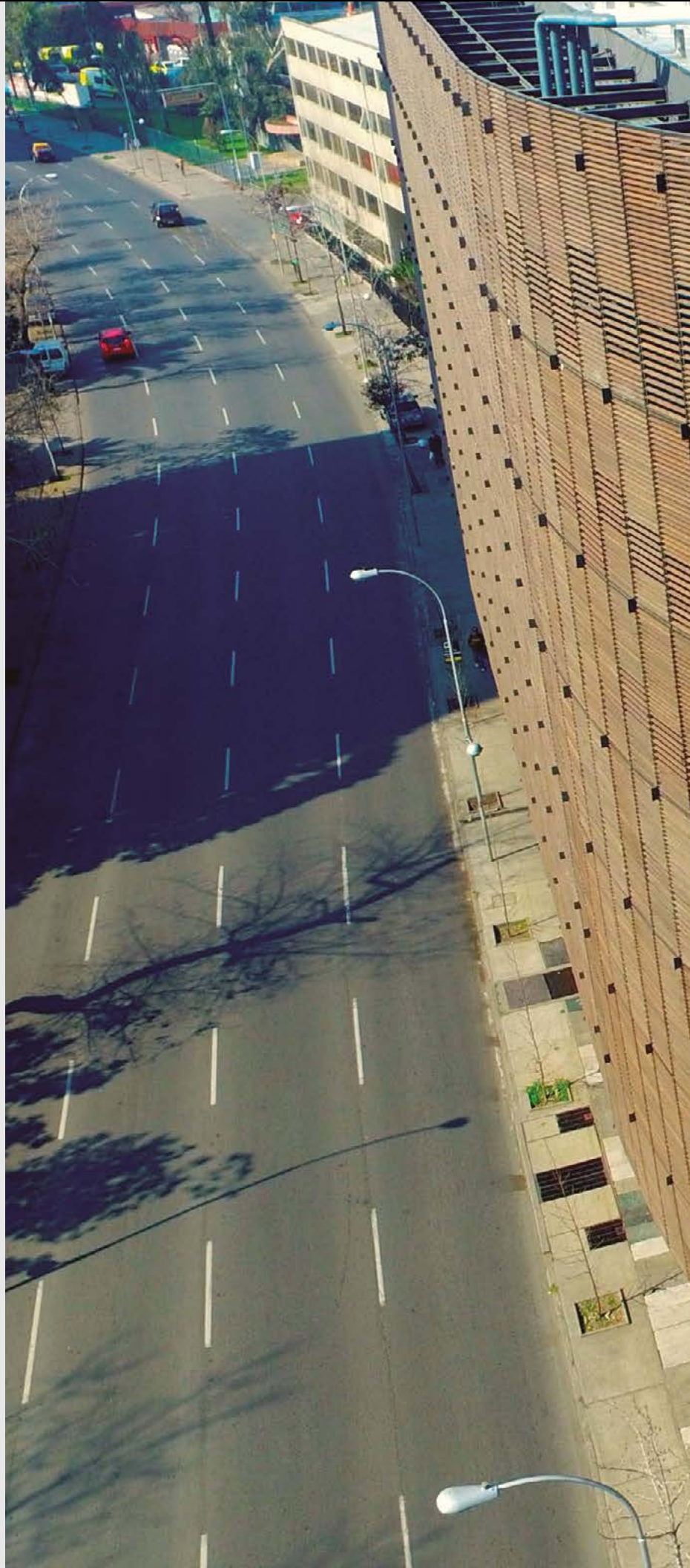



# WOODBRISE

Solar Control | Wooden sunlouvers



The Woodbrise louver offers solar protection for exterior or interior use with fixed or mobile wooden slats in sliding shutters, folding shutters or fixed shutters. This updated collection is now available in three types of wood: Bamboo N-finity, Bamboo Extreme and Lenga. It also includes various slat shape options. The traditional Woodbrise 66 uses a shape similar to Woodbrise 100 and rectangular and trapezoidal slat sections also have been designed. The lenga options are available in various colors: tobacco, platinum, natural, honey, golden and chocolate. The Woodbrise 25 x 85 louver is a great choice for façades that require fixed sun protection with a system of supports composed of aluminum profiles and clips, ensuring dimensional stability of the slats and offering the option of continuous and/or curved façades.

## WOODBRISE 66

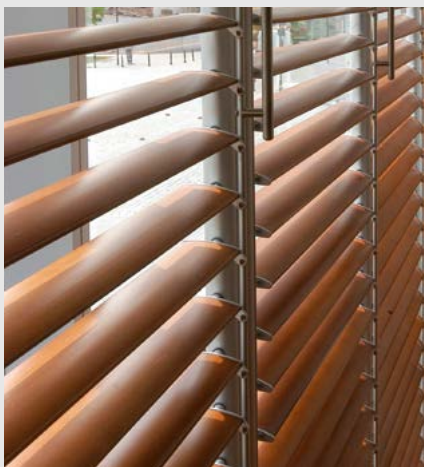
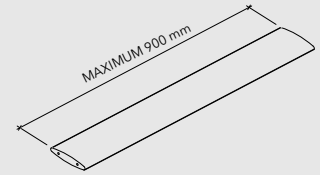
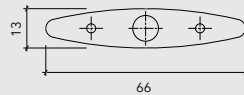

## WOODBRISE 100

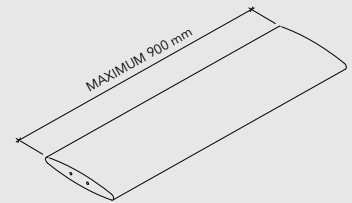
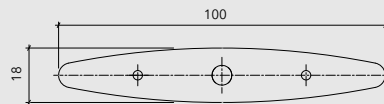

## WOODBRISE 30 x 18

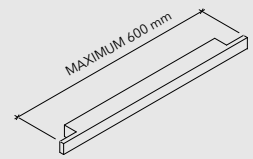
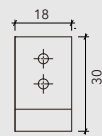

## TRAPEZOIDAL WOODBRISE

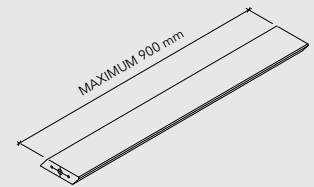
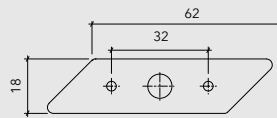

## WOODBRISE 25 x 85

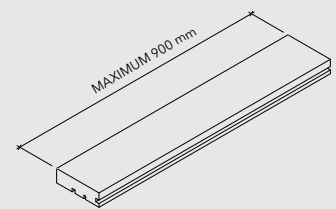

## TECHNICAL DESCRIPTION

PRODUCT	MATERIAL	WEIGHT (kg/ml)	MAXIMUM LENGTH* (mm)	GEOMETRIC DRAWING
WOODBRISE 66	BAMBOO N-FINITY	0,47	900	
	LENGA	0,39		
WOODBRISE 100	BAMBOO GB	0,95	900	
	LENGA	0,79		
WOODBRISE 30 x 18	BAMBOO N-FINITY	0,39	600	
	BAMBOO XTREME	0,65		
	LENGA	0,32		
TRAPEZOIDAL WOODBRISE 80 x 18	BAMBOO N-FINITY	0,76	900	
	LENGA	0,64		
	BAMBOO XTREME	1,30		
WOODBRISE 25 x 85	BAMBOO N-FINITY	1,42	900	
	LENGA	1,18		

\*Maximum length is considered to be between supports.

- Finishing: Smooth
- Colors: Tobacco, platinum, natural, honey, golden and chocolate
- Uses: Sun louvers (interior and exterior)



# INSTALLATION

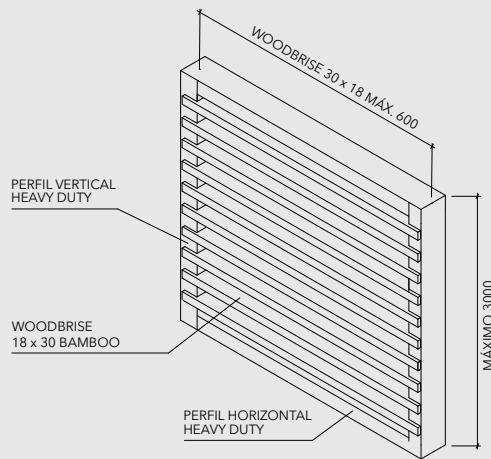
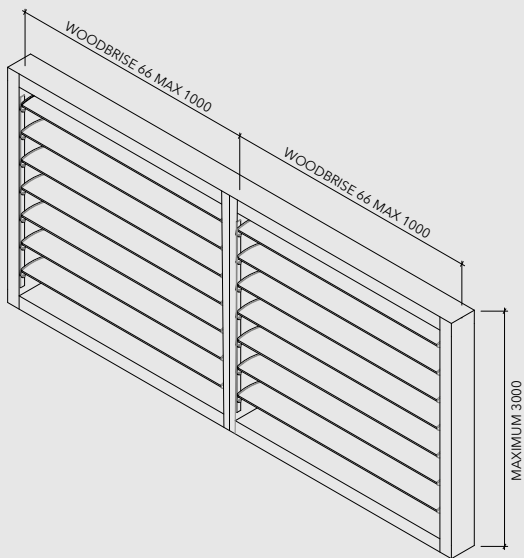

## WOODBRISE 66 - 100 MOBILE

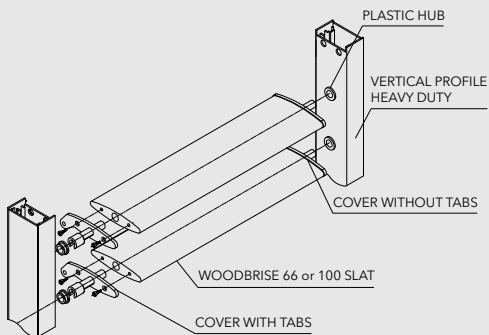

## INSTALLATION 66 MOBILE

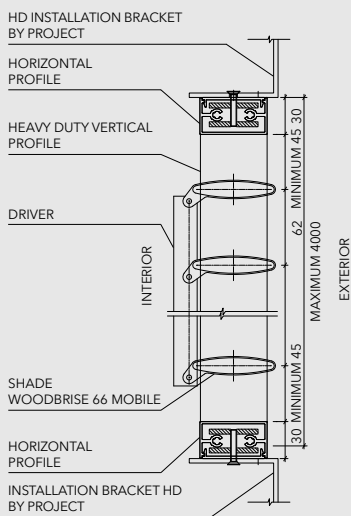

## HORIZONTAL CUT 66 - 100 FIXED

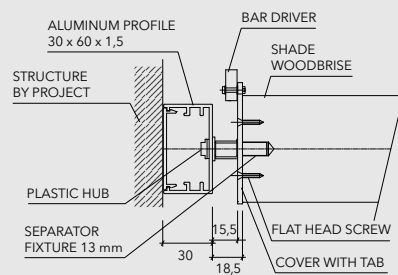

## HORIZONTAL CUT 66 - 100 FIXED

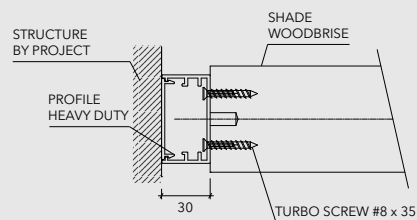

## DETAIL OF BAR SETTING

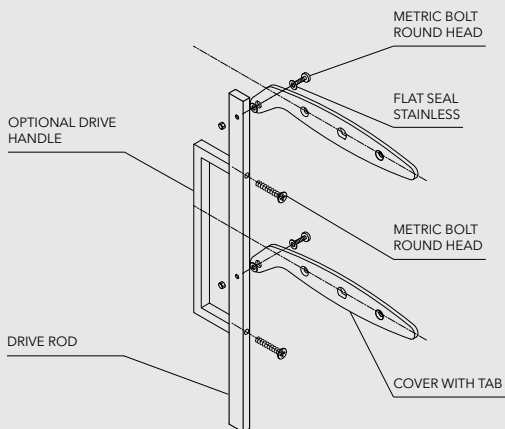

## WOODBRISE 66 - 100 FIXED

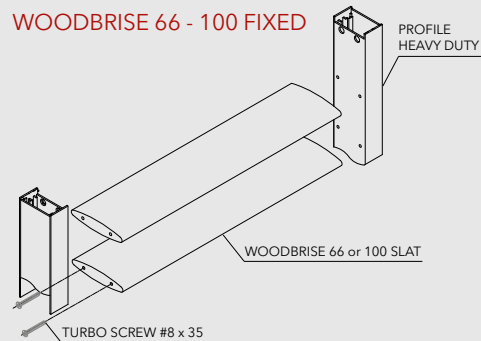

# WOODBRISE 25 x 85

Solar Control | Wooden sunlouvers



SUPPORT PROFILE

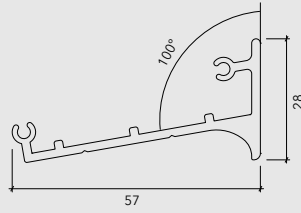

BRACKET

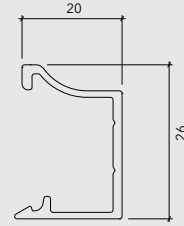

WOODBRISE SLAT 25 x 85  
BAMBOO GB 36 x 100

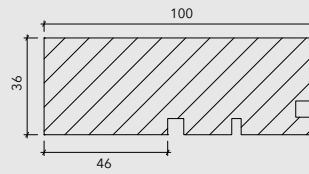

WOODBRISE SLAT 25 x 85  
BAMBOO GB 18 x 100

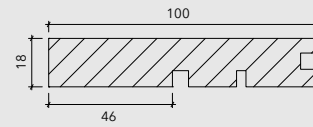

SECTION VIEW (FRAMED INSTALLATION)

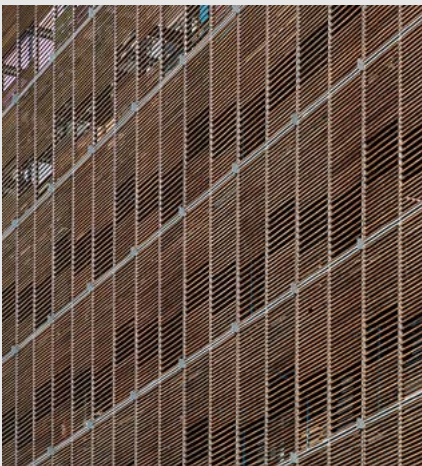
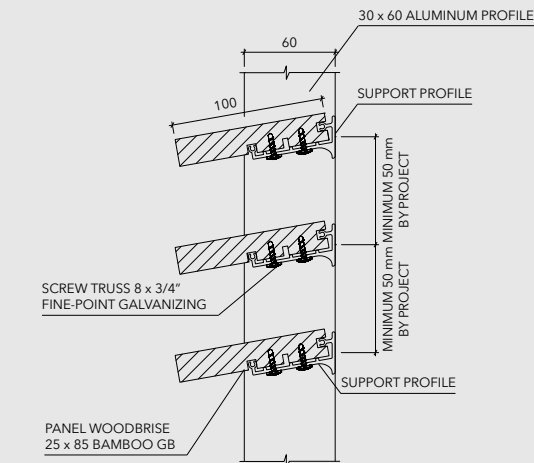
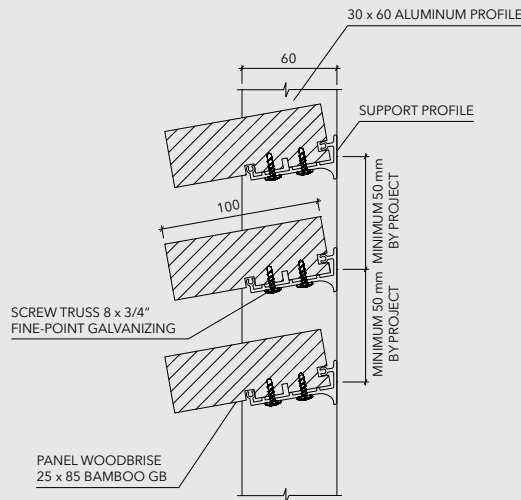

## MOUNTING (OUTSIDE FRAME)

### DETAIL

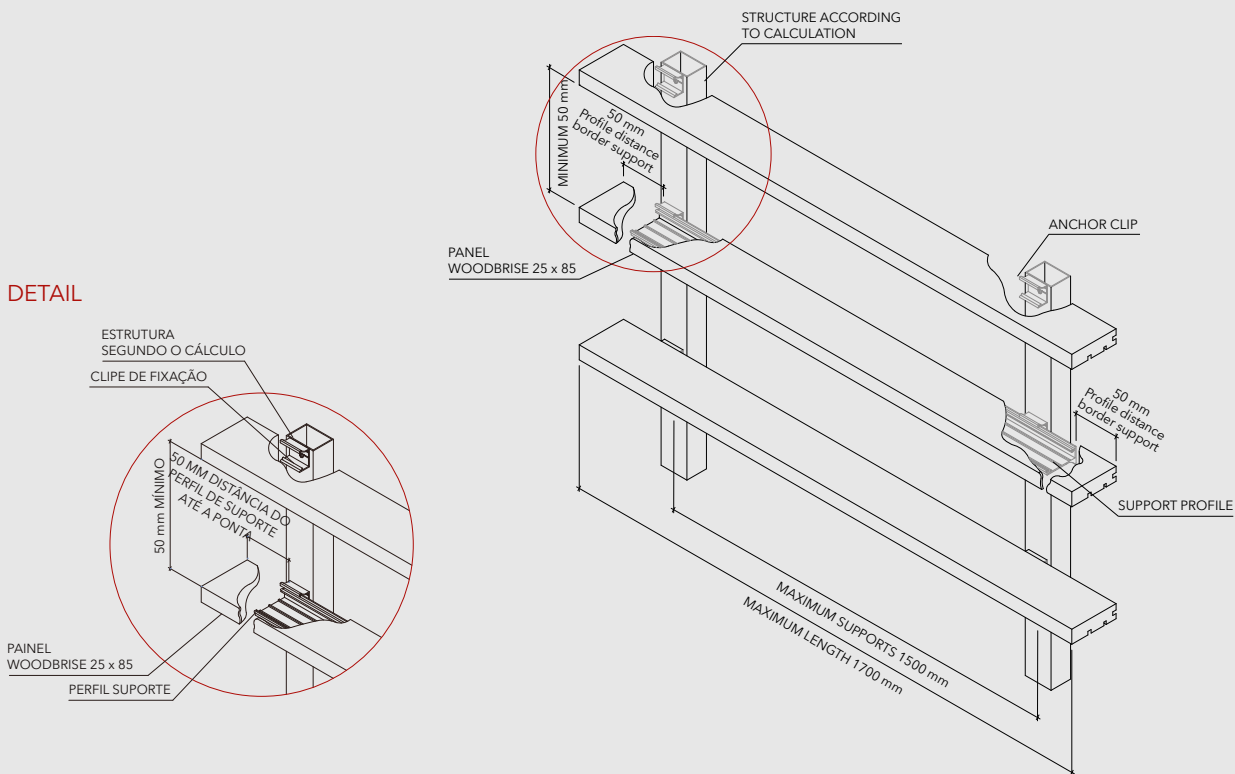

### DETAIL VIEW (NOT FRAMED)

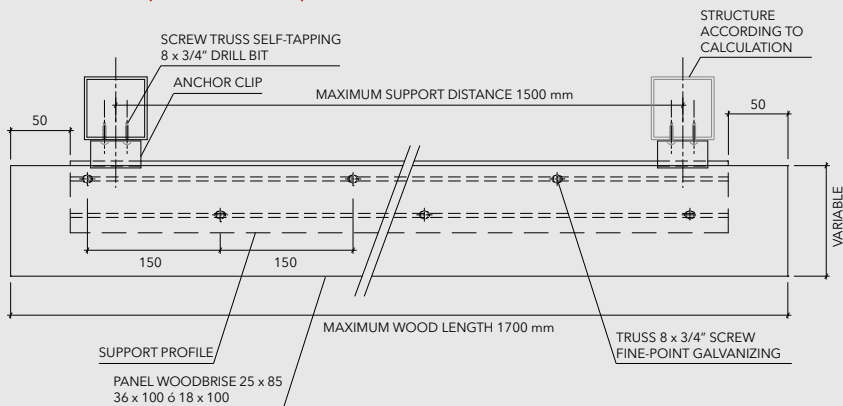

### LATERAL VIEW INSTALLATION

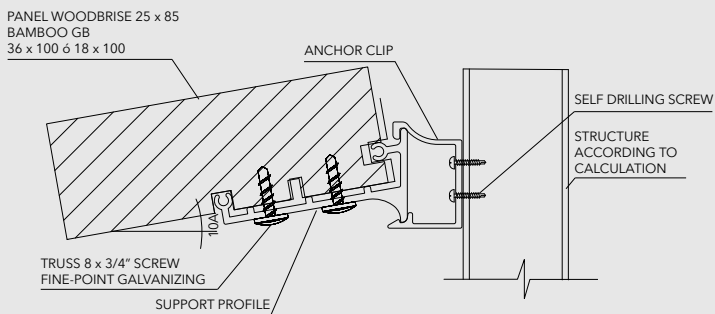

Note: The components of this product are constantly being improved and developed, so modifications may be made. The measurements listed on this Technical Sheet are expressed in millimeters (mm). In order to ensure that the product works correctly, the installation should always be handled by an authorized distributor using all of the accessories listed and in accordance with Hunter Douglas technical specifications.

# WOODBRISE 25 x 85

Solar Control | Wooden sunlouvers





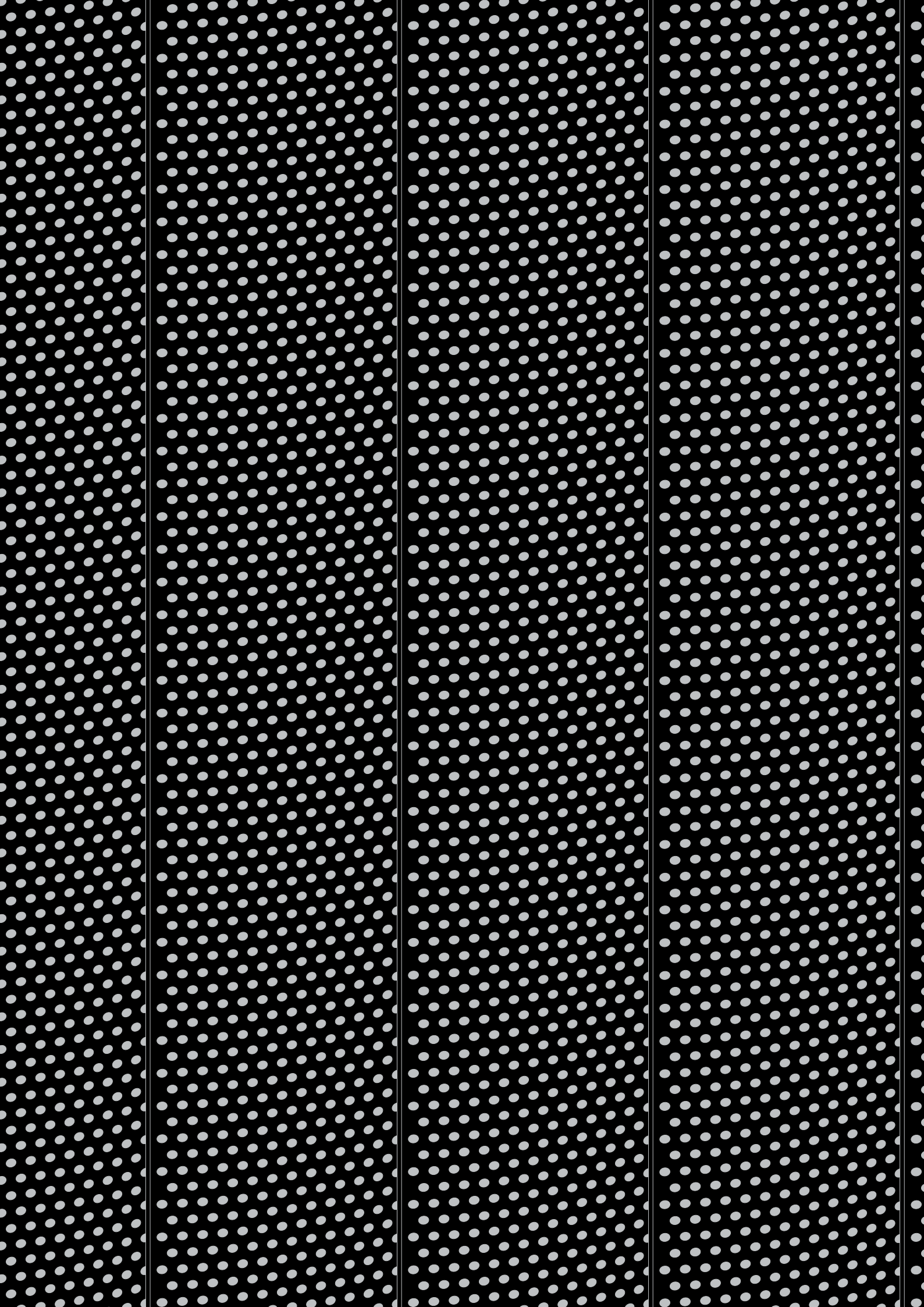



**MOVEABLE SUNSCREENS**

# AEROSCREEN PLUS

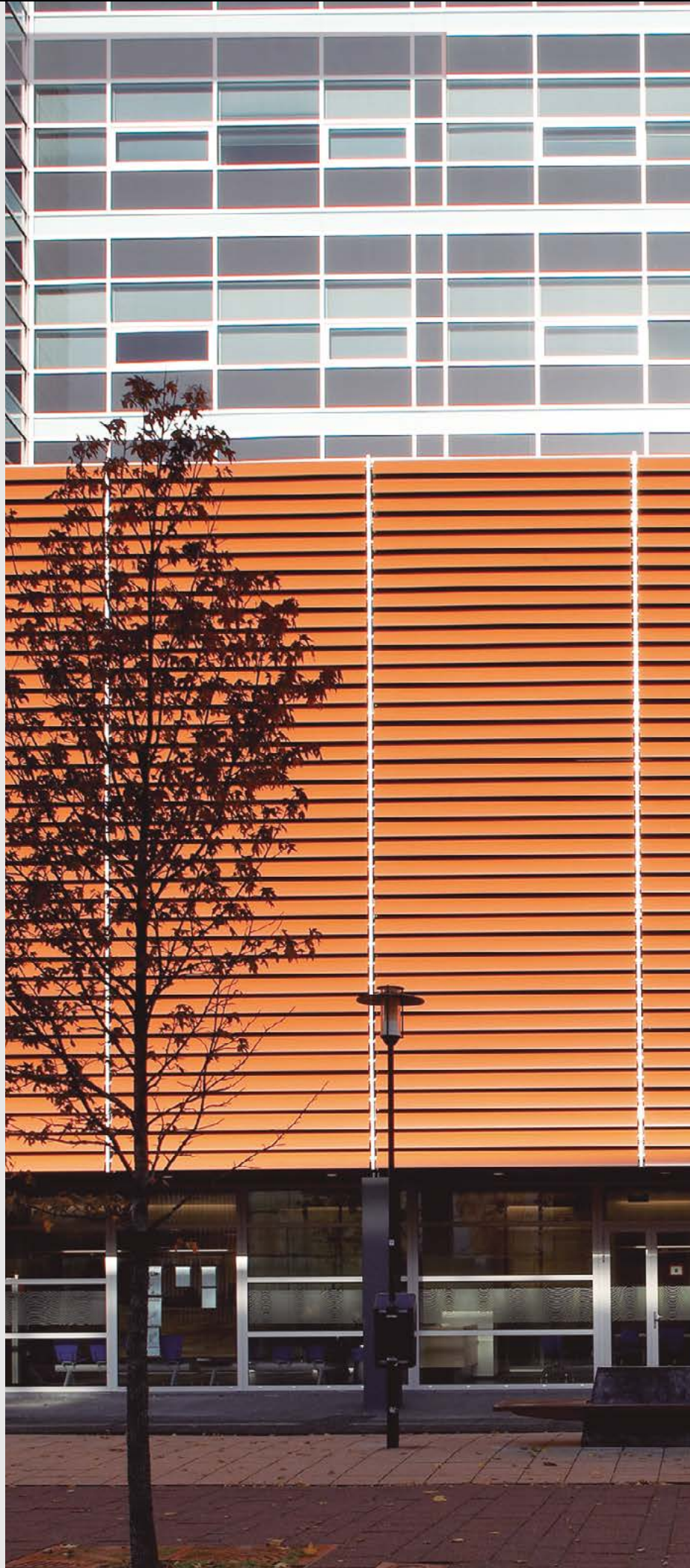





# AEROSCREEN PLUS

Solar Control | Moveable sunlouvers



The Aeroscreen Plus sun louver has been designed to cover buildings with a double skin and to provide an effective solution in passive solar protection, maintaining contact between the interior and exterior of the building due to its transparency.

## TECHNICAL DESCRIPTION

### WEIGHT CHART

PRODUCT	MATERIAL	THICKNESS (mm)	WEIGHT kg/m <sup>2</sup>
AEROSCREEN PLUS C - 300	ALUMINUM	1,2	10,6
	ALUZINC	0,8	14,5
AEROSCREEN PLUS F - 300	ALUMINUM	1,2	10,5
	ALUZINC	0,8	14,1
AEROSCREEN PLUS C - 370	ALUMINUM	1,2	9,5
	ALUZINC	0,8	13,3
AEROSCREEN PLUS F - 450	ALUMINUM	1,2	8,6
	ALUZINC	0,8	12,0

Note: The exterior product is available in other materials including wood, 3Form and other metals, which must be validated by the technical department.

- Material: Zinc-aluminum, weathering steel, aluminum, copper, wood, 3Form
- Thickness: 1,2 mm (aluminum)
- Colors: Available in over 100 standard colors and in custom colors
- Finish: Smooth or perforated, wood or mineral grain
- Uses: Louver
- Maximum length: 3,5 m (perforated or smooth)
- Efficiency: Varies by project



## COMPONENTS

### AEROSCREEN BRACKET ASSEMBLY

REAR COVER

CENTRAL CORE

BASE BRACKET

STRUCTURE BLOCK

DRIVER HANDLE

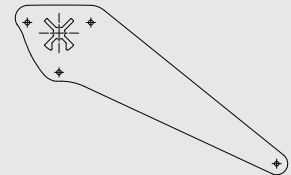
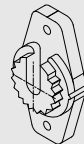
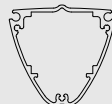
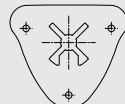

ENDCAP

AXIS

### MOBILE BRACKET ASSEMBLY

### FIXED BRACKET ASSEMBLY

### DRIVER ROD

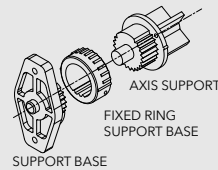
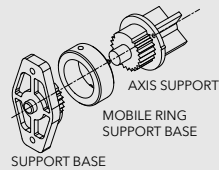

### RIB TYPES

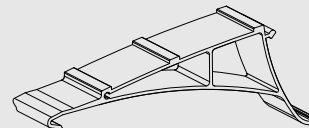
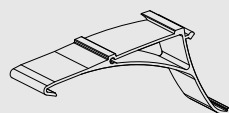

AEROSCREEN PLUS C-300 RIB

AEROSCREEN PLUS C-370 RIB

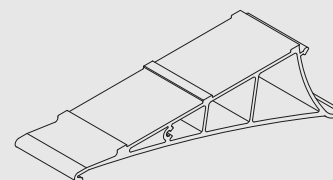
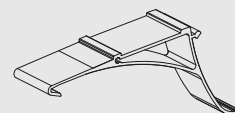

RIB AEROSCREEN PLUS F-300

RIB AEROSCREEN PLUS F-450



## INSTALLATION

### AEROSCREEN PLUS HORIZONTAL ASSEMBLY

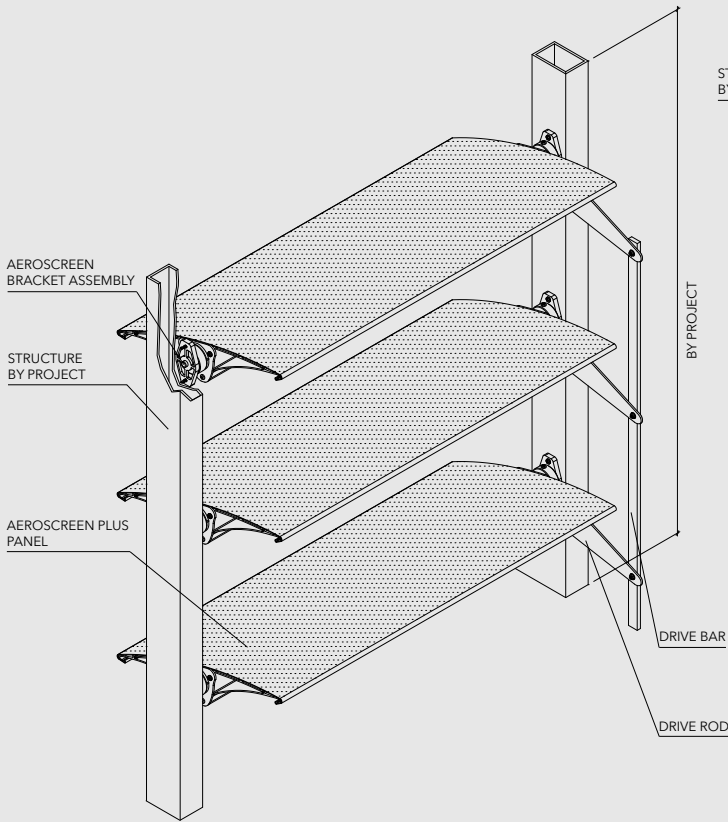

### AEROSCREEN PLUS VERTICAL ASSEMBLY

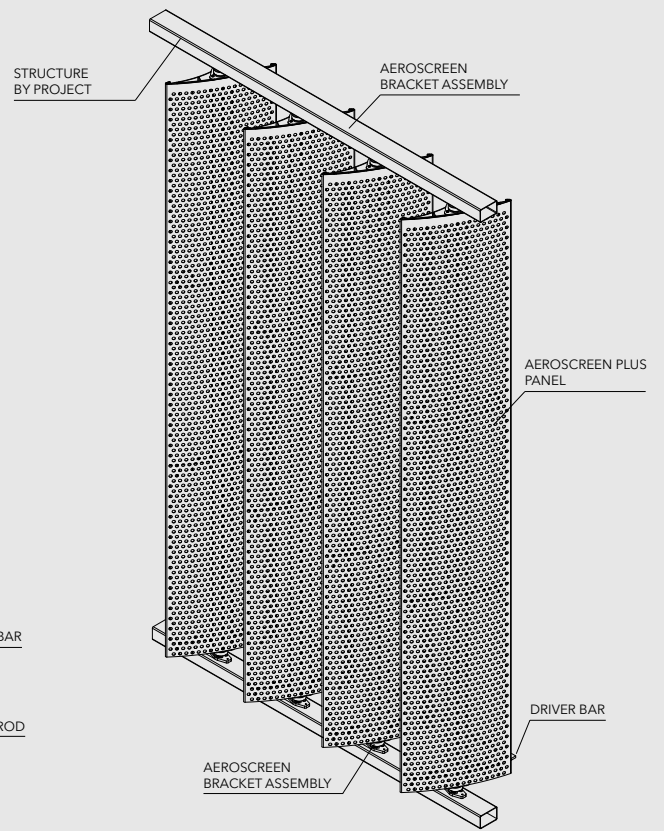

### AEROSCREEN PLUS VERSIONS

#### AEROSCREEN PLUS C - 300

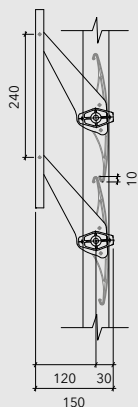
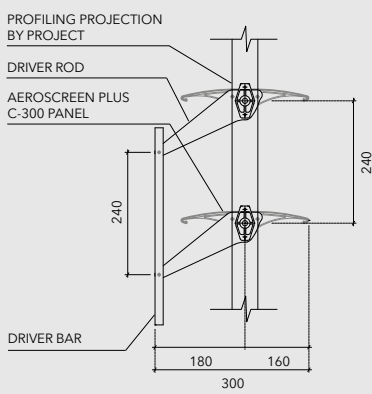

#### AEROSCREEN PLUS C - 370

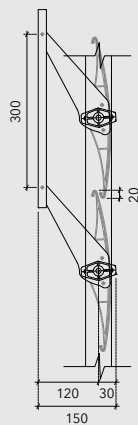
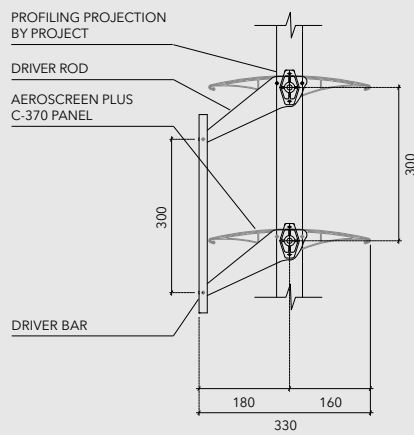

#### AEROSCREEN PLUS F - 450

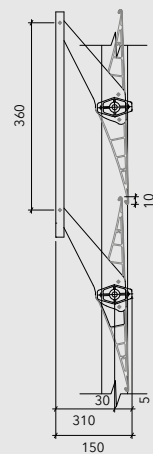
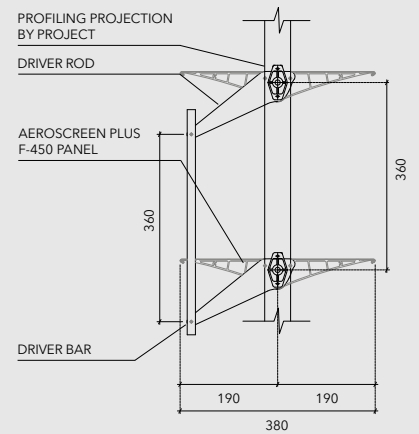

# AEROSCREEN PLUS

Solar Control | Moveable sunlouvers

## INSTALLATION

### SPECIAL OPTIONS

#### PERFORATED FRAME

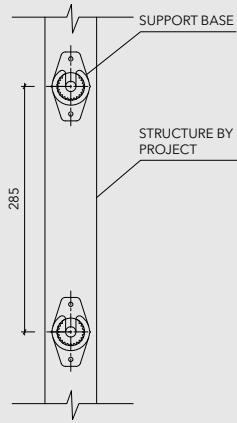

SPACING  
AEROSCREEN PLUS C300 - F300

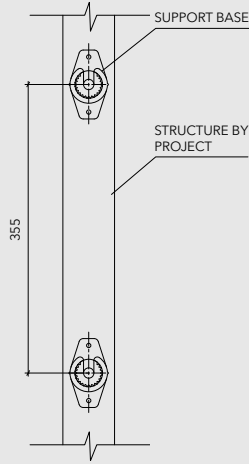

SPACING  
AEROSCREEN PLUS C 370 - F450

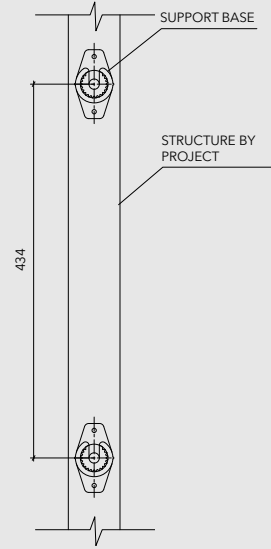

SPACING  
AEROSCREEN PLUS C 370 - F450

#### OTHER OPTIONS

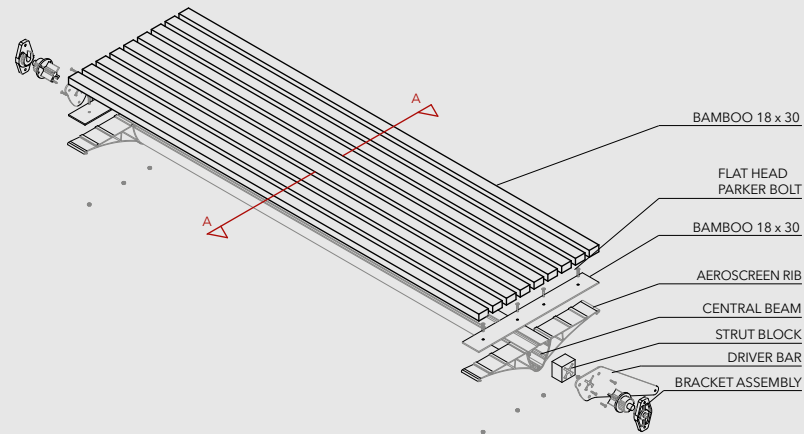

SECTION A-A

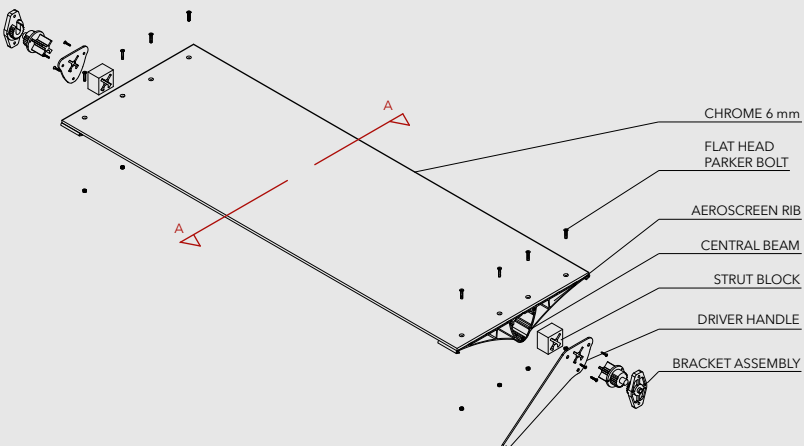
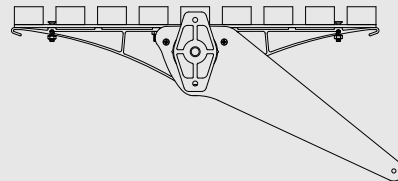

SECTION A-A

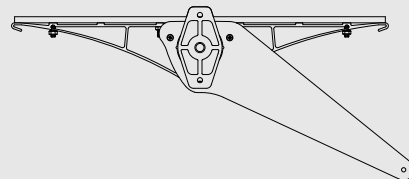

FORMATS

AEROSCREEN PLUS C- 300

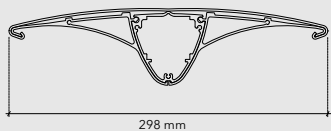

AEROSCREEN PLUS F- 300

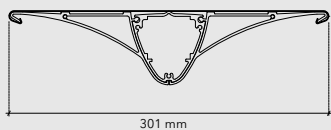

AEROSCREEN PLUS C- 370

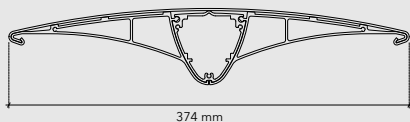

AEROSCREEN PLUS F- 450

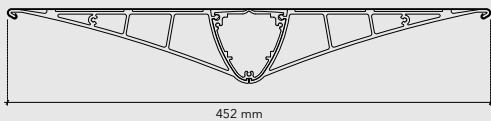

AEROSCREEN PLUS ASSIMÉTRICO C - 300

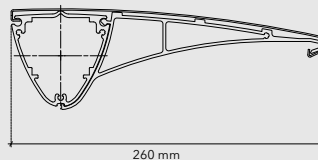

POSSÍVEIS PRODUTOS A SEREM DESENVOLVIDOS

AEROSCREEN PLUS C- 370 / F- 300

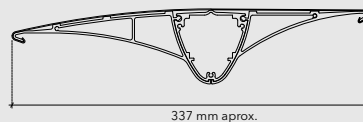

AEROSCREEN 300\*

AEROSCREEN 300 PANEL SKIN  
PERFORATED OR UNPERFORATED

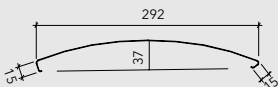

AEROSCREEN PANEL CHROMA  
(ACHRYLIC PANEL)

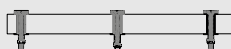

AEROSCREEN RIB  
MATERIAL: ALUMINIUM

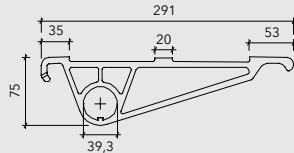

AEROSCREEN 300 RIB  
MATERIAL: ALUMINIUM

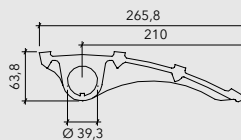

FLAT AEROSCREEN RIB  
MATERIAL: ALUMINIUM

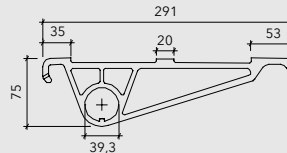

EXTRUDED TUBE  
AEROSCREEN  
Ø 39mm  
MATERIAL: ALUMINIUM



DRIVER HANDLE  
AEROSCREEN  
MATERIAL: ALUMINIUM



AEROSCREEN  
EXTREME AXIS



AEROSCREEN  
FIXED SYSTEM  
RING



AEROSCREEN  
MOBILE  
BRACKET RING



AEROSCREEN  
END BRACKET



\*Prior versions only for repositioning or expansion.

Note: The components of this product are constantly being improved and developed, so modifications may be made. The measurements listed on this Technical Sheet are expressed in millimeters (mm). In order to ensure that the product works correctly, the installation should always be handled by an authorized distributor using all of the accessories listed and in accordance with Hunter Douglas technical specifications.

# AEROWING









## INSTALLATION

### INSTALLATION WITH SLIDING SHUTTER SYSTEM

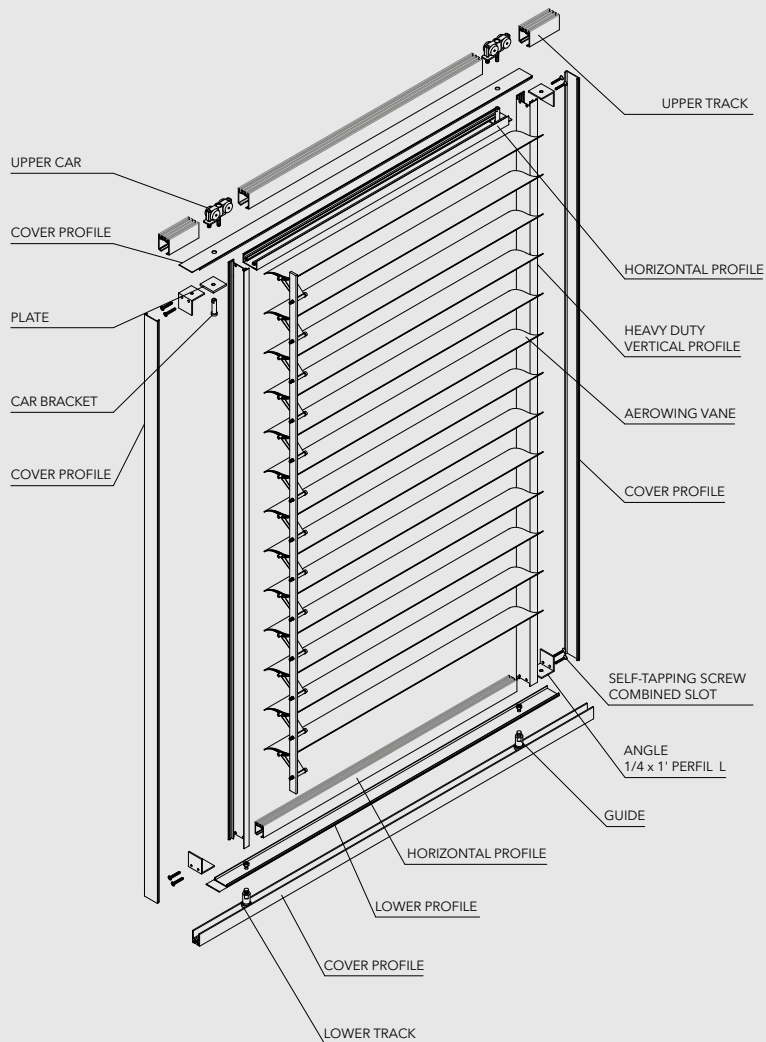

### INSTALLATION AS OVERHEAD SCREEN

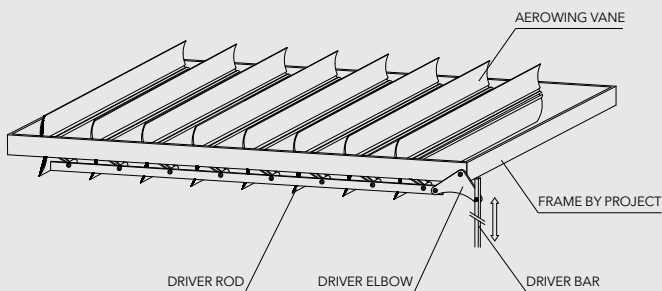

### CROSECTION VIEW

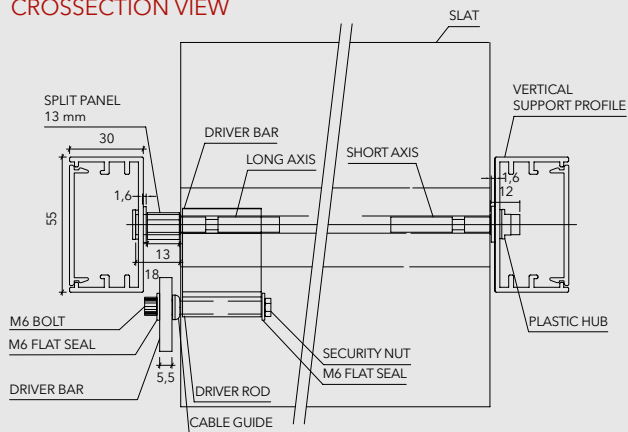

Note: The components of this product are constantly being improved and developed, so modifications may be made. The measurements listed on this Technical Sheet are expressed in millimeters (mm). In order to ensure that the product works correctly, the installation should always be handled by an authorized distributor using all of the accessories listed and in accordance with Hunter Douglas technical specifications.

# METALBRISE

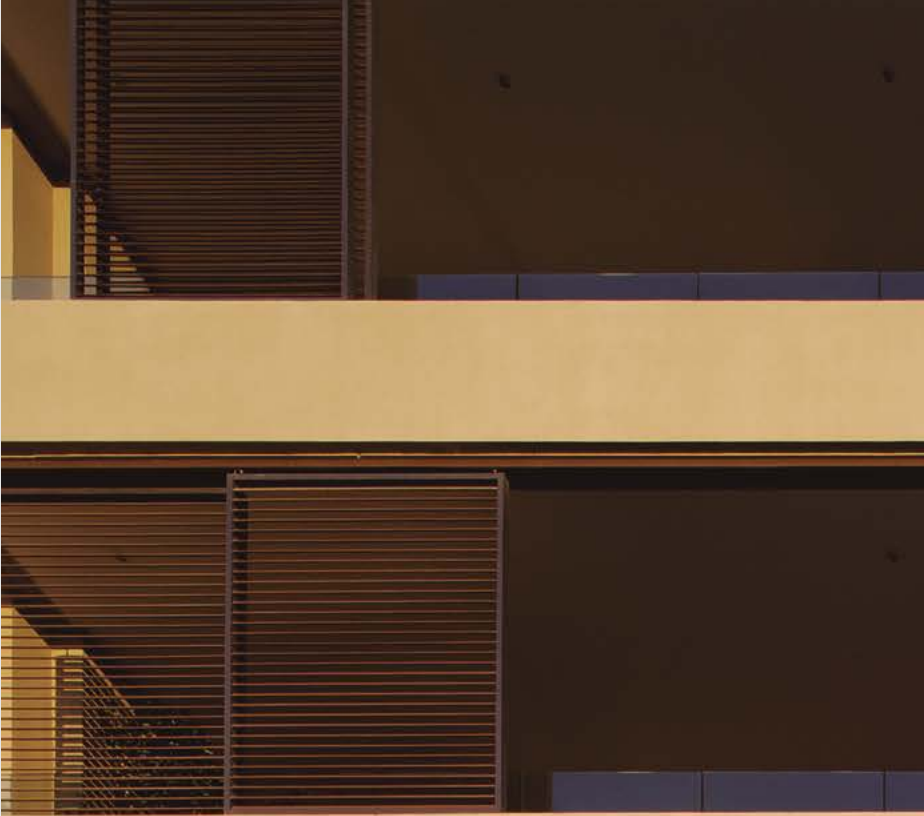



# METALBRISE

Solar Control | Moveable sunlouvers



The Metalbrise louver is a product designed for institutional, commercial and residential projects that can be used for exterior and interior applications. Its low-weight components allow it to be installed in both new and remodeling projects. It is available in mobile and fixed format. The slats of the latter are attached based on a preset angle. The Metalbrise louver slats are installed on an aluminum frame that can be fixed, sliding or folding and provides an aesthetic sun control solution. The injected aluminum covers, which are weather- and impact-resistant, have an integrated wing that is attached to the bar link, allowing for mechanical or motorized swiveling. The covers on the fixed option are plastic.

## TECHNICAL DESCRIPTION

PRODUCT	MATERIAL	THICKNESS (mm)	WEIGHT (kg/m <sup>2</sup> )	EFFICIENCY* (panels / m <sup>2</sup> )
METALBRISE	ZINC-ALUMINIUM	0,4 - 0,5	10	17,8
METALBRISE	ALUMINIUM	0,7	4,3	17,8

\*Based on a standard separation of 56 mm to the axis.

- Colors: Available in over 100 standard colors, custom colors, woodgrains finish or mineralgrains finish
- Finish: Smooth
- Uses: Louver
- Length Maximum: 1500 mm to the axis
- Covers: ALUMINIUM (mobile option) and PVC (fixed option)
- Other materials: Aluminium

### COMPONENTS

#### MOBILE OPTION

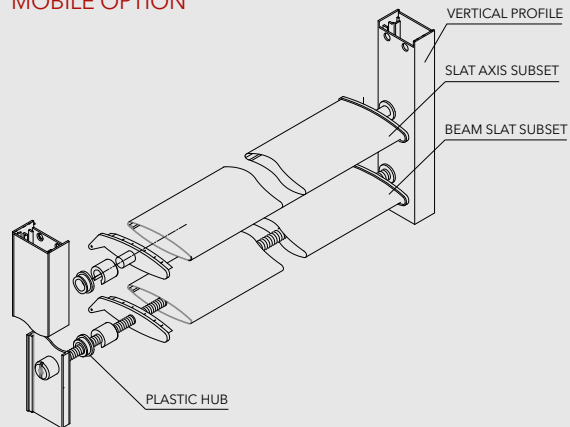

#### MOBILE SLAT CROSSSECTION VIEW

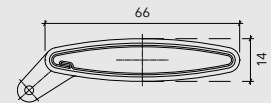

#### FIXED OPTION

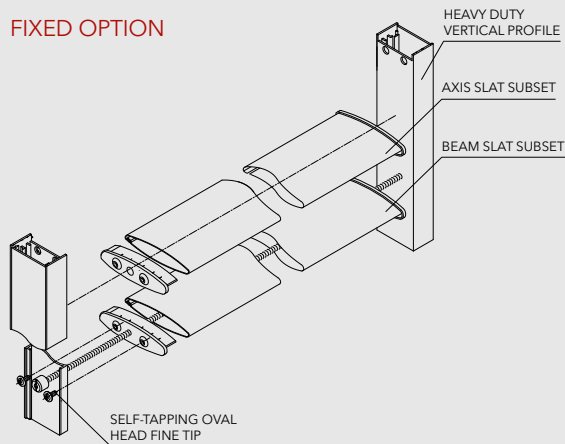

## ASSEMBLY

The mobile Metalbrise louver is composed of a set of metal slats linked through a mechanical system that allows for synchronized swiveling movement in order to regulate the amount of sunlight and the view. The set is assembled using Hunter Douglas heavy duty extruded aluminum sections. The slats for the fixed option have plastic covers which can be set at a specific angle.

Note: This product is also recommended in sliding and folding shutter systems.



## INSTALLATION

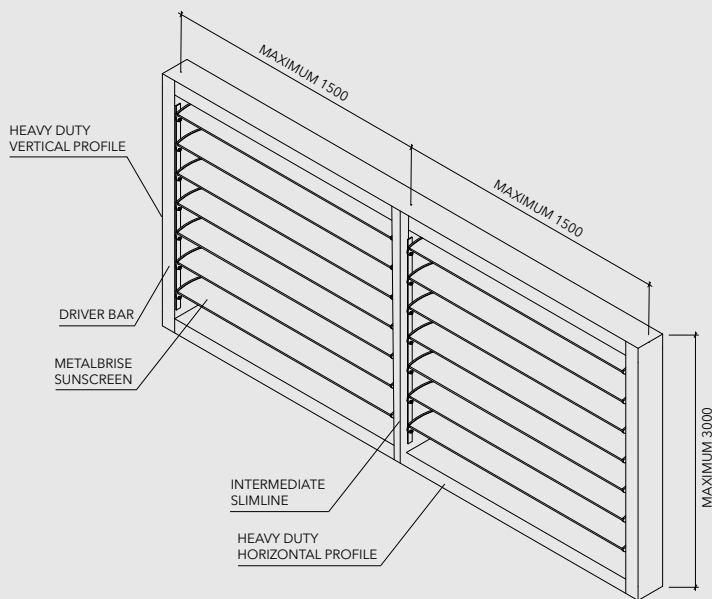

DETAIL DRIVER BAR

DETAIL FIXED OPTION INSTALLATION FIXED FRAME INSTALLATION

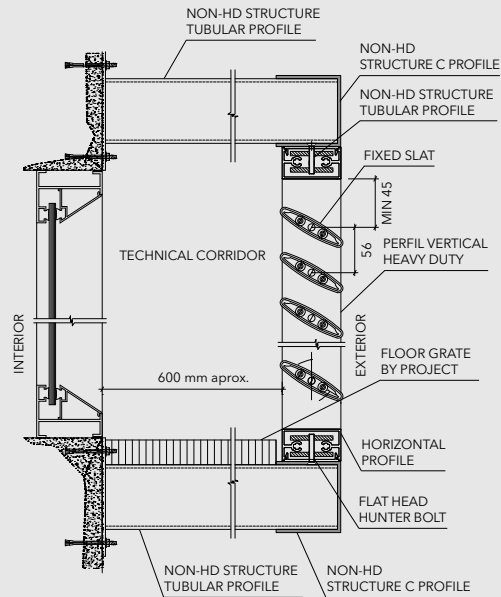
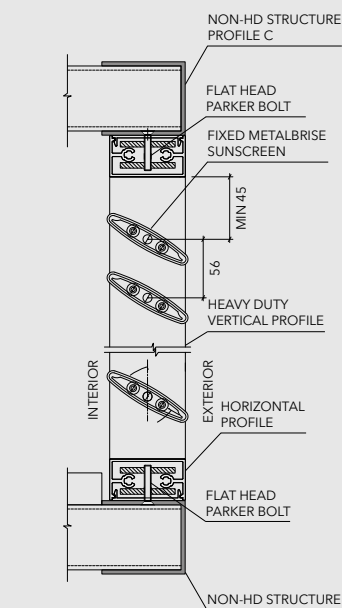
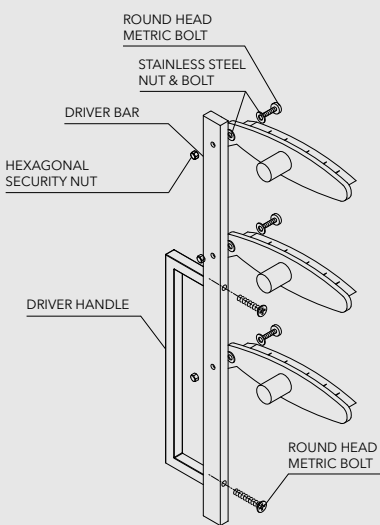

DETAIL INSTALLATION FIXED OPTION FRAMED

DETAIL FOLDING SHUTTER

DETAIL SLIDING SHUTTER

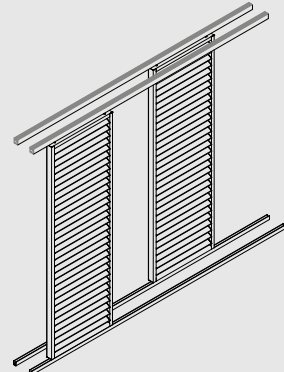
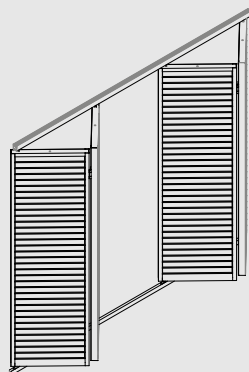
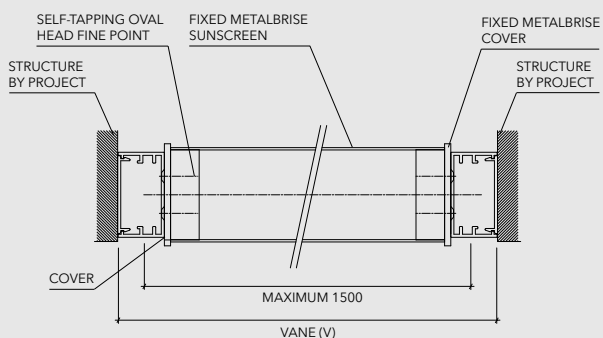

Note: The components of this product are constantly being improved and developed, so modifications may be made. The measurements listed on this Technical Sheet are expressed in millimeters (mm). In order to ensure that the product works correctly, the installation should always be handled by an authorized distributor using all of the accessories listed and in accordance with Hunter Douglas technical specifications.

# METALBRISE

Solar Control | Moveable sunlouvers





# TERMOBRISE







# TERMOBRISE

Solar Control | Moveable sunlouvers



The TermoBrise louver is a product designed for building façades to protect them from the impact of sunlight and external noise. The slats can be installed vertically or horizontally depending on the design. The low weight of the TermoBrise louver components allow this product to be attached to any type of structure with minimal static loads, which means that they can be used for new construction as well as remodeling projects. The interior is filled with injected polyurethane which provides a high level of rigidity, insulation and low final weight. The end caps have an integrated wing that is linked to the action bar, which allows them to swivel. Both end caps rest on grifted plastic hubs, which ensures smooth swiveling of the panels. The action may be manual or motorized.

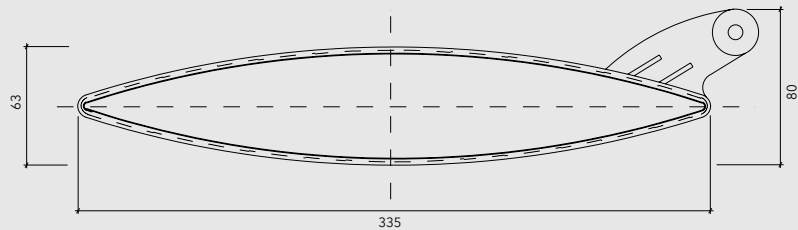
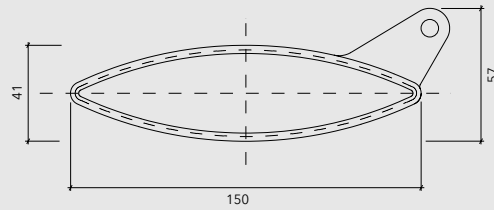

## TECHNICAL DESCRIPTION

PRODUCT	MATERIAL	THICKNESS (mm)	WEIGHT (kg/m <sup>2</sup> )	EFFICIENCY (ml/m <sup>2</sup> )
TERMOBRISE 150	ALUZINC	0,4	8,3	7,40
TERMOBRISE 335		0,5	9,8	3,14

- Colors: More than 100 standard and special colors on request
- Finishing: Unperforated, Woodgrains or Mineralgrains
- Uses: Viewbraker and/or sunlouver
- Other materials: Aluminium, copper, zinc, corten steel

VIEWBRAKER	MAX. LENGTH VERTICAL SLAT (mm)	MAX. LENGTH HORIZONTAL SLAT (mm)
TERMOBRISE 150	3500	3000
TERMOBRISE 335	4000	3500

## ASSEMBLY

The TermoBrise louver is supported by 60 x 30 x 2 mm extruded aluminum profiles on which the panels rest supported by self-lubricating nylon hubs. The extruded aluminum profiles are affixed to the structure of the façade using brackets or other elements designed specifically for each case or need. The louver is composed of panels linked by a mechanical system that allow for synchronized swiveling movement so that the light and view can be regulated.

## INSTALLATION

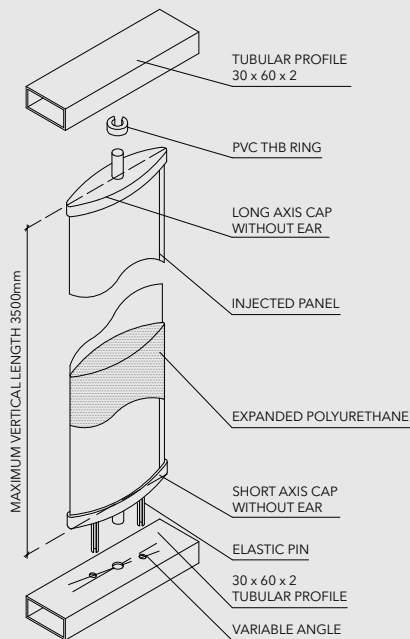

### TERMOBRISE 150/335 COMPONENTS

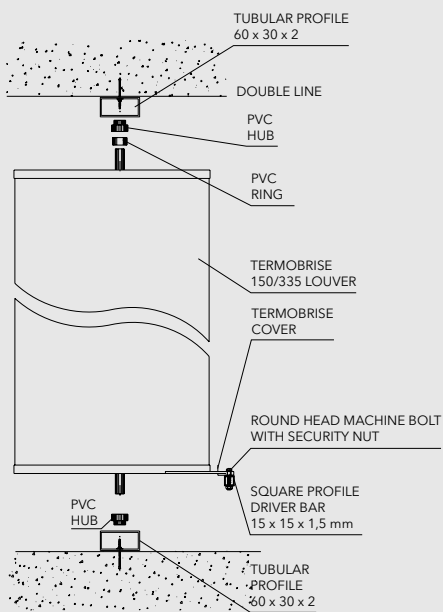

### DETAILS OF UPPER AND LOWER END TERMOBRISE 150

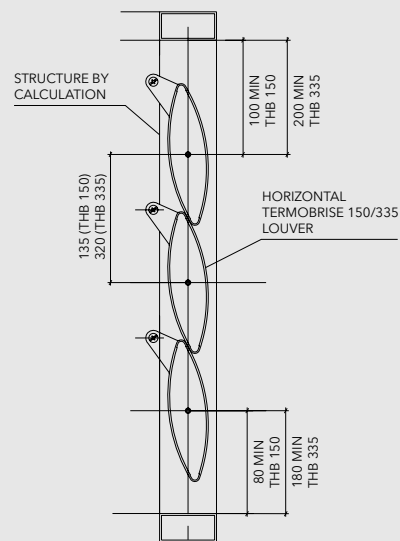

### DETALLE SLIDING SHUTTER

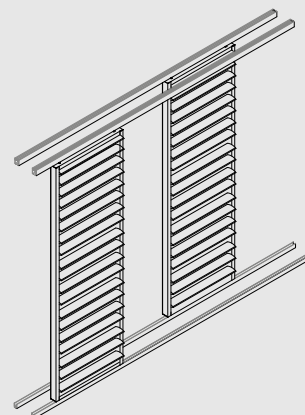

### TERMOBRISE 335

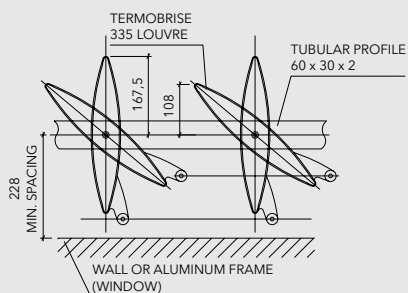

### TERMOBRISE 150

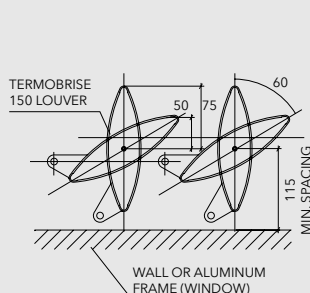

Note: The components of this product are constantly being improved and developed, so modifications may be made. The measurements listed on this Technical Sheet are expressed in millimeters (mm). In order to ensure that the product works correctly, the installation should always be handled by an authorized distributor using all of the accessories listed and in accordance with Hunter Douglas technical specifications.

# WINDSCREEN

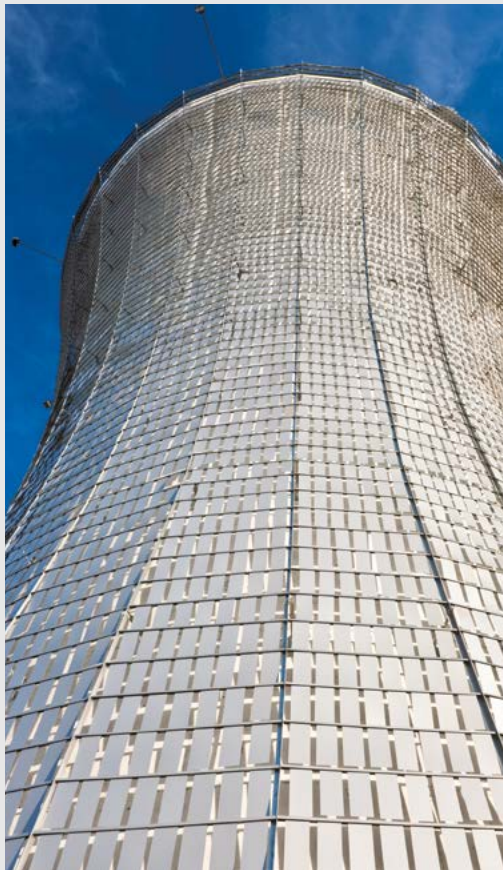



# WINDSCREEN

Solar Control | Moveable sunlouvers



The Windscreen louver is composed of aluminum sheets that pivot on a plastic hub that is mounted on a steel string. The sheets form a surface that moves with the wind. This provides a kinetic façade that is visually very attractive and is always changing.

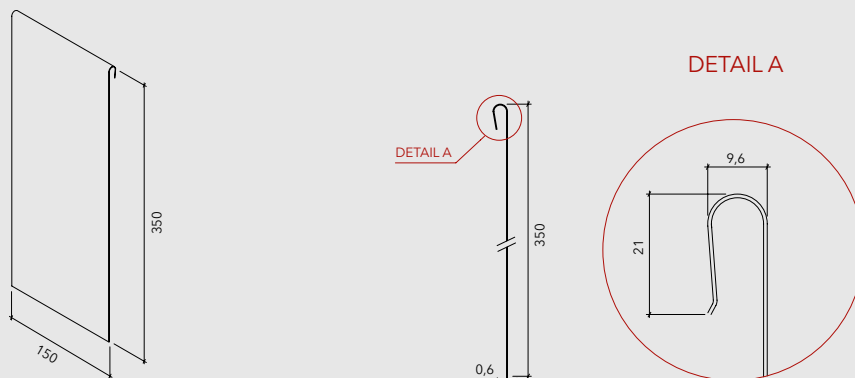

## ACCESORIOS WINDSCREEN

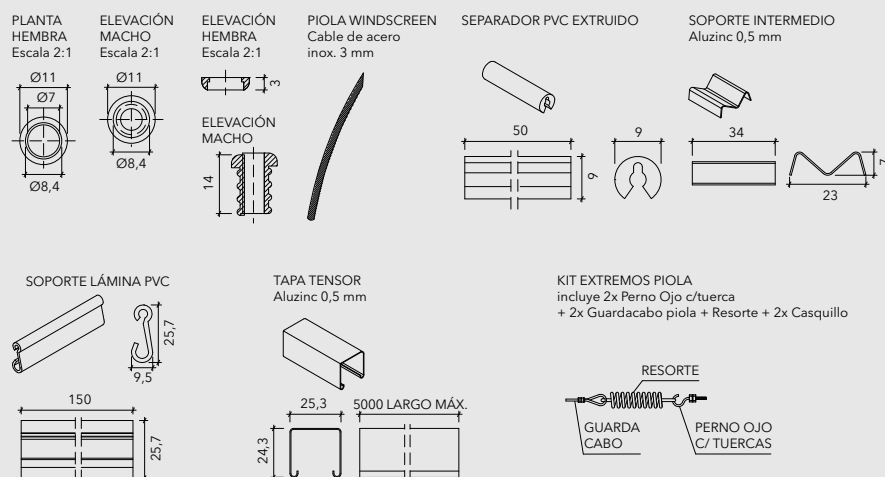

## TECHNICAL DESCRIPTION

PRODUCT	MATERIAL	THICKNESS (mm)	WEIGHT (kg/m <sup>2</sup> )
WINDSCREEN	ALUMINIUM	0,6	1,73

Note: Calculated with foil plus tensioning cap.

- Material: Aluminium
- Thickness: 0,6 mm
- Colors: More than 100 standard and special colors on request
- Uses: Viewbraker
- Finishing: Perforated, unperforated
- Measure: 150 x 350 mm, for other measures consult the Hunter Douglas technical department
- Performance: 12.5 sheets estimated based on m<sup>2</sup>

## ROTATION TEST

The product (sheet, sheet support and stainless steel wire) was submitted to a rotation test to evaluate material wear. The test involved 10 million 360° cycles and the aforementioned components did not present noticeable wear.

Note: In order to guarantee that this product functions properly, a Hunter Douglas authorized maintenance plan should be developed.

## INSTALLATION

### ISOMETRIC VIEW

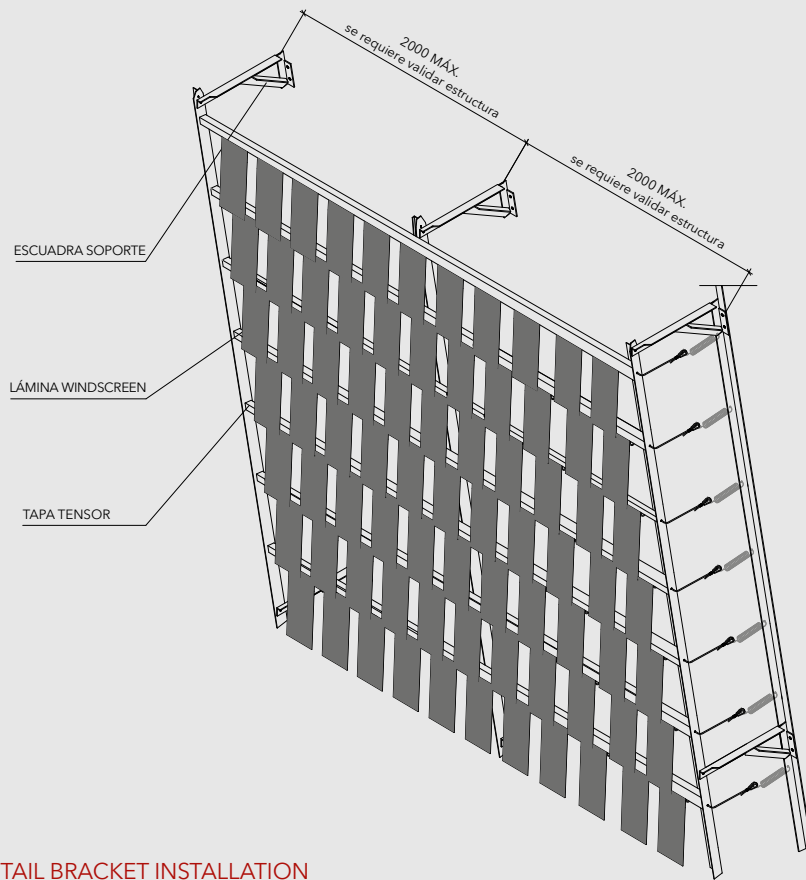

### ISOMETRIC DETAIL BRACKET INSTALLATION

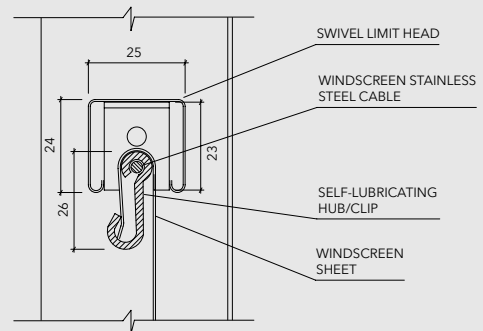
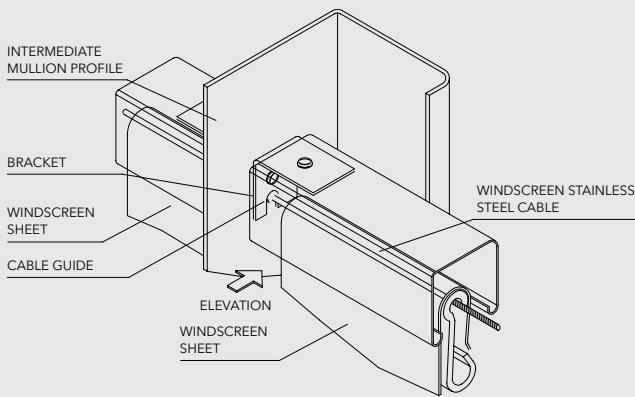

### ISOMETRIC INSTALLATION OF MOUNTING COMPONENTS

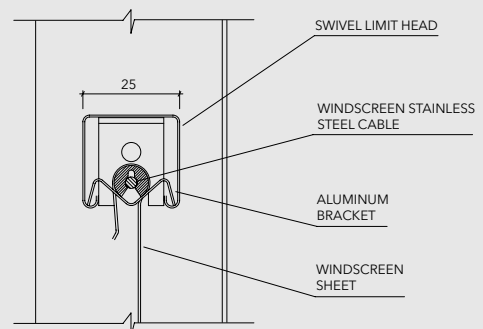
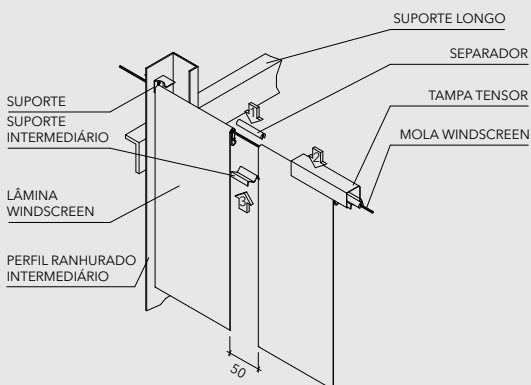

Note: The components of this product are constantly being improved and developed, so modifications may be made. The measurements listed on this Technical Sheet are expressed in millimeters (mm). In order to ensure that the product works correctly, the installation should always be handled by an authorized distributor using all of the accessories listed and in accordance with Hunter Douglas technical specifications.

# MOTORIZATION







# MOTORIZATION

Solar Control | Moveable sunlouvers



Over the past few years, there has been important development in automation of solar control systems. This is mainly the result of the need to provide greater comfort to the user. Movement has thus taken on an important role because it allows users to regulate the amount of light that enters a space. In order to meet these needs, we present the general characteristics of the Elero brand German motors, which are compatible with Somfy automation accessories, both of which are brands sold by Hunter Douglas.

The seven sunlouvers that Hunter Douglas offers can be mobile and motorized.

## INSTALLATION



AEROSCREEN PLUS P 300 LOUVER

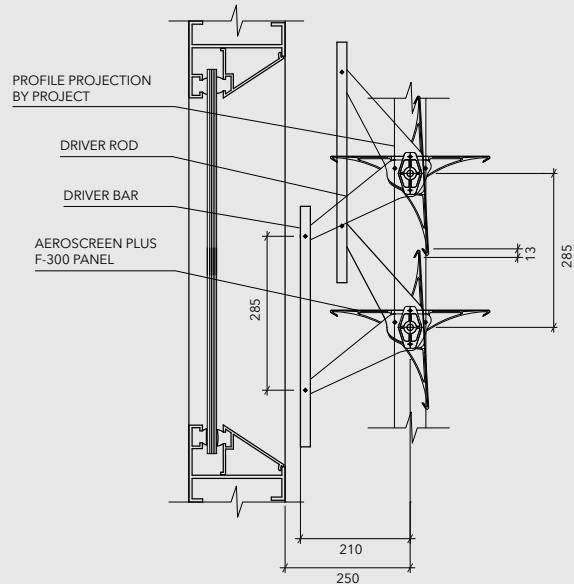

AEROSCREEN PLUS C-300

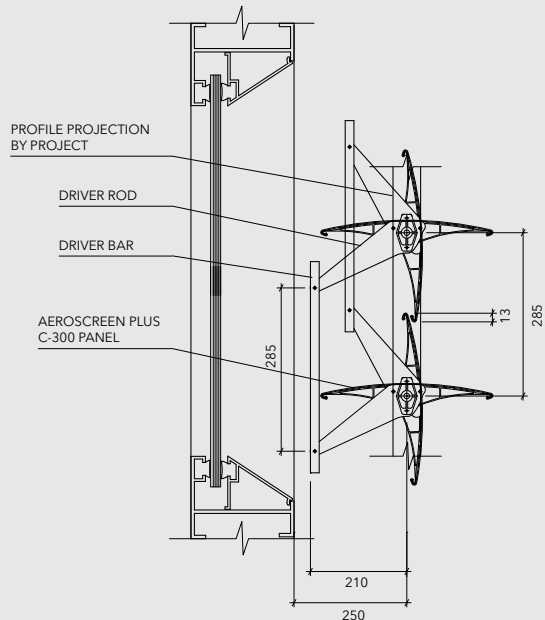

TERMOBRISE 150 LOUVER

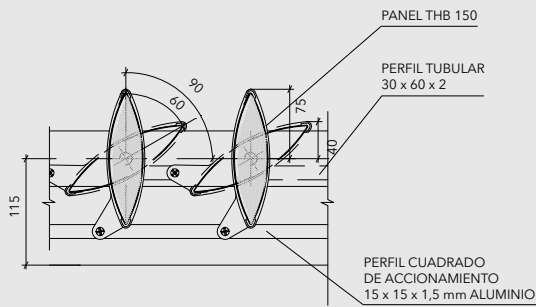
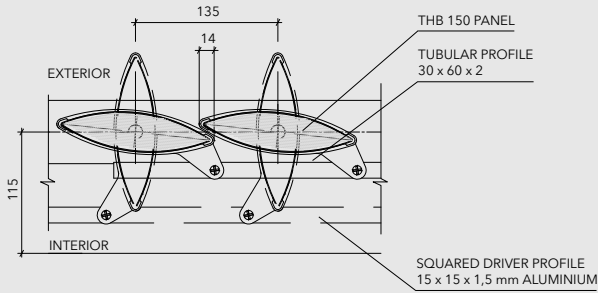

TERMOBRISE 335 LOUVER

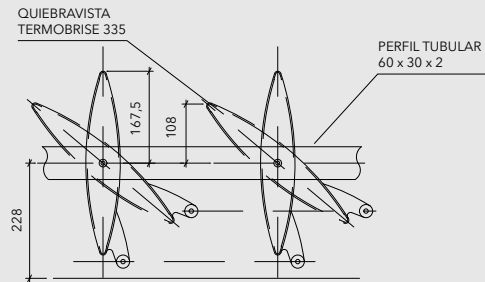
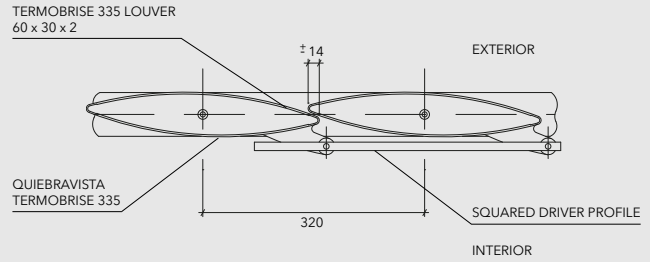

MOBILE WOODBRISE 66

UPPER END

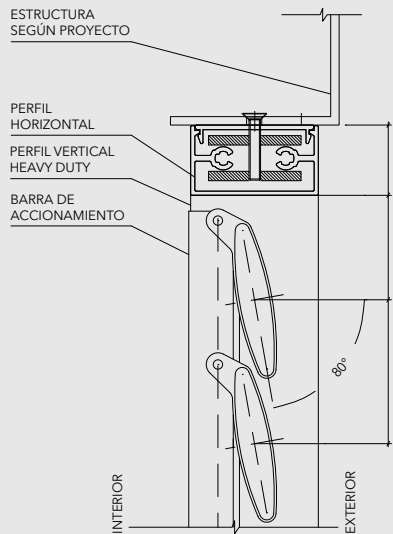

LOWER END

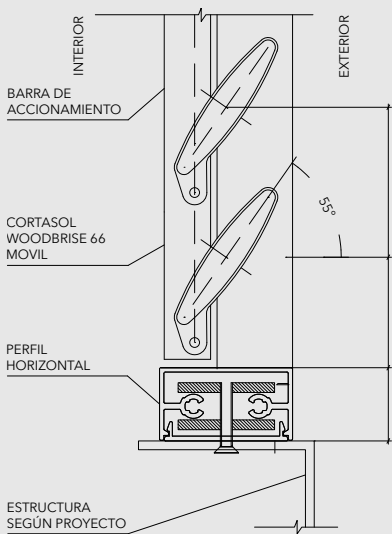

ELERO MOTOR BRACKET

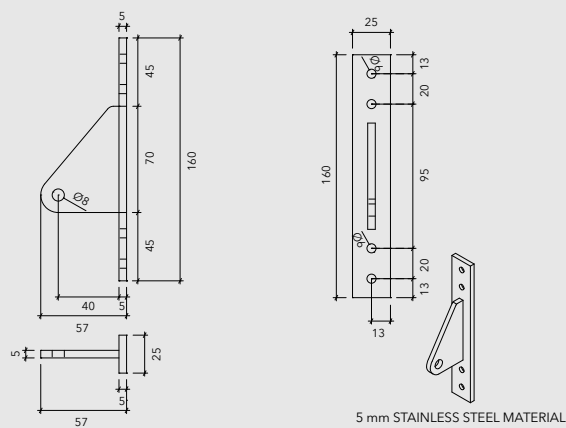

DETAIL INSTALLATION OF MOTOR TO ACTION BAR

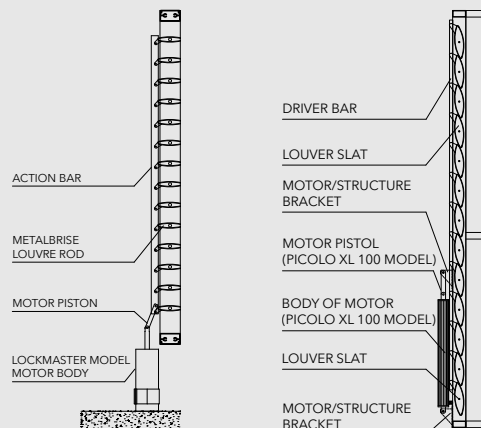

# MOTORIZATION

Solar Control | Moveable sunlouvers

## INSTALLATION

### WOODBRISE 100

#### UPPER END

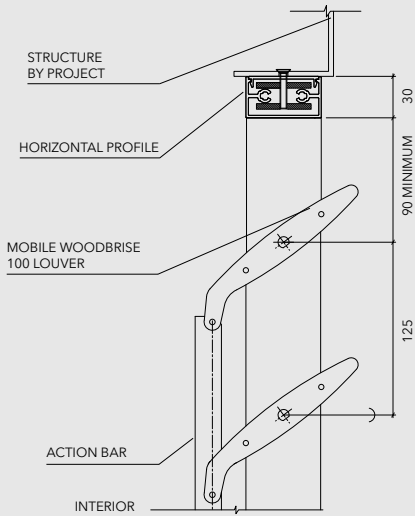

#### LOWER END

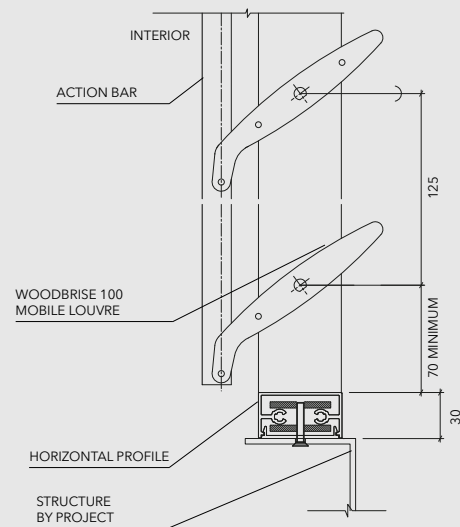

### METALBRISE

#### UPPER END

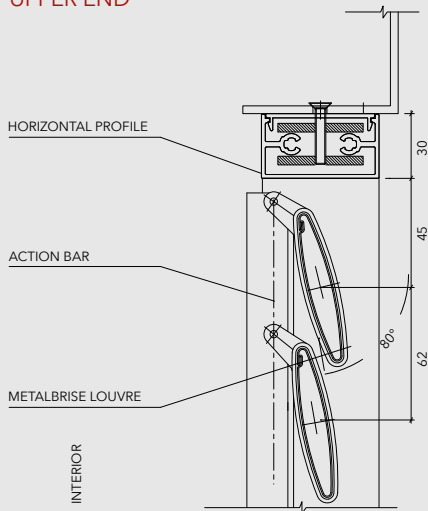

#### LOWER END

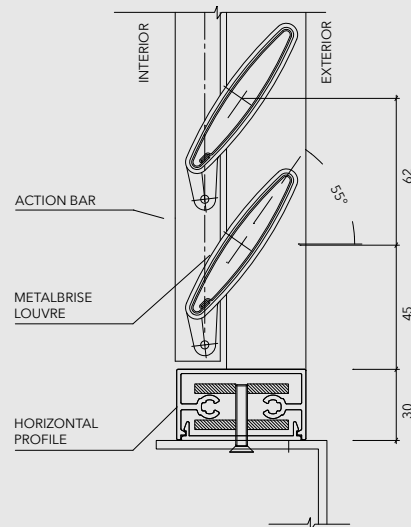

Due to the swivel characteristics of each louvre shown above, the motor stroke is determined by the following lengths:

LOUVER	MOTOR STROKE (mm)
AEROSCREEN PLUS	200
TERMOBRISE 150	100
TERMOBRISE 335	200
WOODBRISE 66	50
WOODBRISE 100	100
METALBRISE	50
AEROWING	100

## CHARACTERISTICS

- Elero motors are compatible with Somfy brand remote control systems and automation
- The motors are made of 100% weather-resistant stainless steel, which are ideal for exterior façades (IP 65 and IP 67 models)
- Applications for static and dynamic loads
- Easy installation because of its spare and compact casing
- Excellent value

## TECHNICAL DESCRIPTION

The following information corresponds to the linear electric servomotor with rigid rod movement that provides high resistance to loads at the point such that it can generate thrust force that ranges from 50 to 1200 N depending on the model. The available models and their applications are listed below

ELERO MOTOR MODEL	LOUVER
PICOLO XL 200	AEROSCREEN PLUS
	TERMOBRISE 335
PICOLO XL 100	TERMOBRISE 150
	WOODBRISE 100
LOCKMASTER	WOODBRISE 66
	METALBRISE

### MOTOR FOR TERMOBRISE 150 AND WOODBRISE 100 LOUVRES

TECHNICAL DATA FOR PICOLO XL 100 MOTOR	
CASE DIAMETER (mm)	48
THRUST FORCE (N)	1200
CURRENT INTENSITY	0,55 A
POWER	126 W
STROKE SPEED (mm/s)	6 (230V AC) / 5 (24V DC)
STROKE LENGTH (mm)	100
SERVICE VOLTAGE	230 V AC - 50 Hz / 24V DC
NUMBER OF PHASES	1
CASE	STAINLESS STEEL 4301
TYPE OF PROTECTION	IP 65 (WEATHER RESISTANT)

### MOTOR FOR AEROSCREEN PLUS AND TERMOBRISE 335 MOTOR

DATOS TÉCNICOS MOTOR PICOLO XL 200	
CASE DIAMETER (mm)	48
THRUST FORCE (N)	1200
CURRENT INTENSITY	0,55 A
POWER	126 W
STROKE SPEED (mm/s)	6 (230V AC) / 5 (24V DC)
STROKE LENGTH (mm)	200
SERVICE VOLTAGE	230 V AC - 50 Hz / 24V DC
NUMBER OF PHASES	1
CASE	STAINLESS STEEL 4301
TYPE OF PROTECTION	IP 65 (WEATHER RESISTANT)

### MOTOR FOR WOODBRISE 66 AND METALBRISE LOUVRES

TECHNICAL DATA LOCKMASTER MOTOR	
CASE DIAMETER (mm)	61,5
CASE LENGTH (mm)	168
THRUST FORCE (N)	50
CURRENT INTENSITY	0,7 A
POWER	160 W
STROKE SPEED (mm/s)	30
STROKE LENGTH (mm)	50
SERVICE VOLTAGE	230 V ~ 50 Hz / 0,55 A (126 W)
NUMBER OF PHASES	1
CASE	STAINLESS STEEL 4301
TYPE OF PROTECTION	IP 67 0,1 BAR (SUBMERSIBLE TO 1 M UNDER WATER)

PICOLO XL 100 and PICOLO XL 200 motors have IP 65 type protection, which means that they are weather-resistant under the worst environmental conditions. This means that they are ideal for use on exterior façades.

The LOCKMASTER motor has IP 67 type protection, which means that it is submersible up to 1 meter.

In addition, given that they do not require any maintenance, they can be used under extreme conditions and in difficult assembly situations.

All of the motors have an anti-rotation piston. All of the models also work with monophasic current at 230 V. It is also possible to consider 24 V and 12 V continuous-current motors.

# MOTORIZATION

Solar Control | Moveable sunlouvers

## PICOLO XL 100- PICOLO XL 200 MOTOR

XL 100 - 200

XL 100 - 200 POSTERIOR

XL 100

XL 200



## LOCKMASTER MOTOR



## REMOTE CONTROL

These motors can be operated using remote controls or with wall consoles.

SWITCH/ SINGLE MODULE 3C LIGHT/ LIVING: To embed. These modules do not include the box, plate and cover, which must be acquired in the marketplace.

## LIVING



## LIGHT



## ELECTRICAL INSTALLATION DIAGRAM

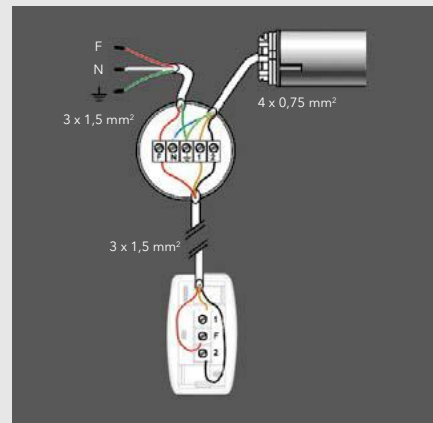

When the project involves a remodeling or rear application, we recommend using a remote control system. For this type of installation, two components must be used: a receiver and a remote.

In the INTEO CENTRALIS product line, the receiver to be used is the RTS-2 Centralis Exterior Receiver.

The RTS-2 Centralis Exterior Receiver allows the product to be activated remotely using a motorized element installed outside. It allows for up to 12 RTS or RT (transmitter) remote control points.

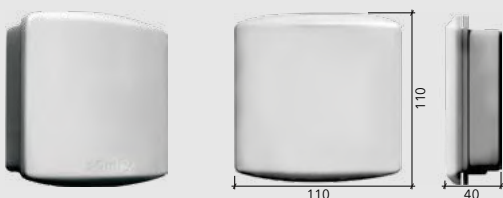

The RTS remote control points include a wide range of models depending on the design, characteristics, etc. These remote control points can be single or multi-channel.

The single channel remote controls have three ergonomic buttons for each function: raise, lower and stop. They can control all of the receivers that are installed within a 100-meter radius in an empty space.

The multi-channel remote controls have the same three buttons plus a button for selecting the channel (four channels plus a general one). Each channel can control a certain number of receivers depending on the motorized elements to be activated.

#### RADIO FREQUENCY TRANSMITTERS

Reach: 20 meters if it has to pass through two reinforced concrete walls (A). 200 meters in an open space (B).



RF TELIS 1: Single channel transmitter that can operate a single motor independently. However, various motors can be added to this single channel if they all are to function at once.

RF TELIS 4: This transmitter can operate four motors independently or various louver shades at the same time on one channel.

The installation of these controls may include a shared bracket depending on the model.

#### REFERENCE IMAGE FOR BRACKET AND TYPE OF TRANSMITTER

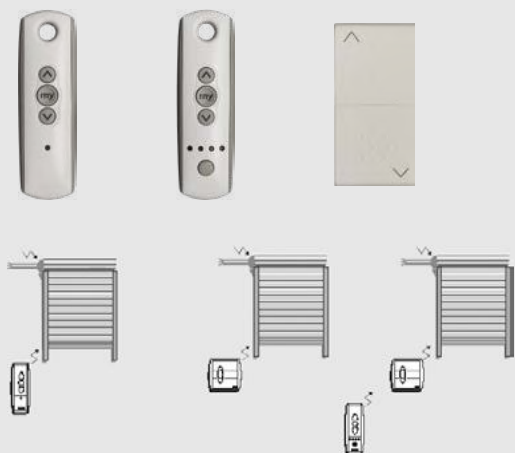

#### WALL BRACKET

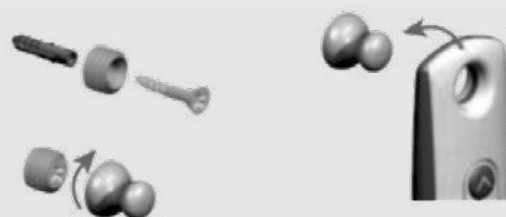

If the project requires using a single remote control to activate more than one motor, a Grouped Control System should be used.

The Hunter Douglas Group Remote is a component that allows you to activate up to four motors at once.

#### GROUP REMOTE CONTROL FOR FOUR MOTORS

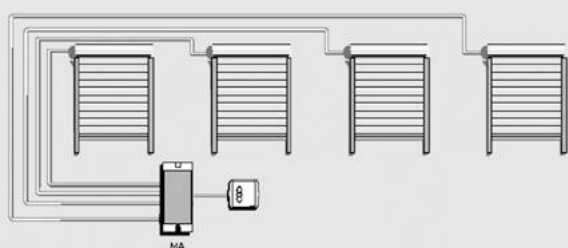

Notes: 1. The components of this product are constantly being improved and developed, so modifications may be made. The measurements listed on this Technical Sheet are expressed in millimeters (mm). In order to ensure that the product works correctly, the installation should always be handled by an authorized distributor using all of the accessories listed and in accordance with Hunter Douglas technical specifications.

2. Hunter Douglas develops special accessories and components for making the motorization of the product more efficient depending on the project.

3. Motorized sunshade projects require specialized details that must be developed in collaboration with the Engineering Department and Sales Area.

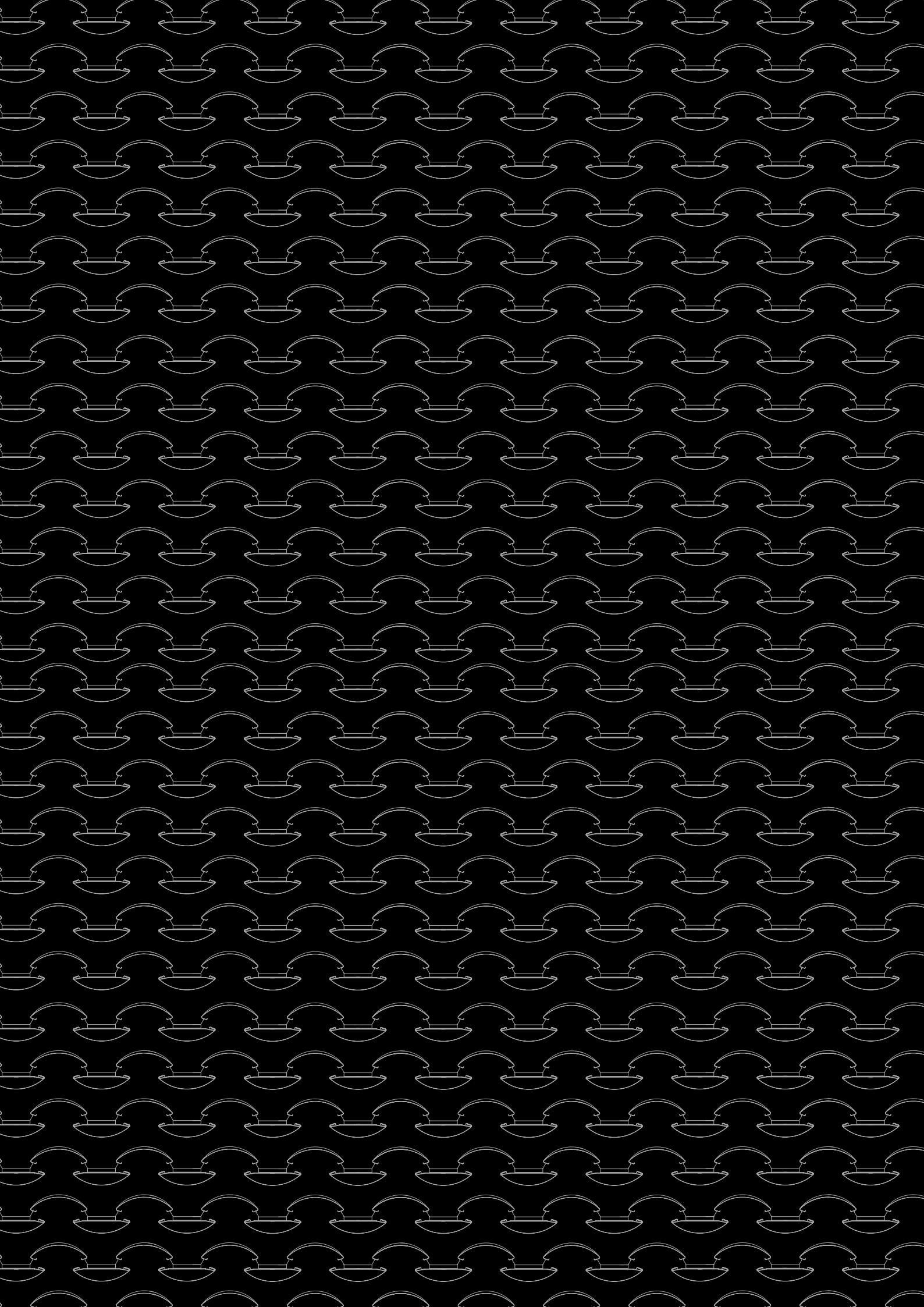



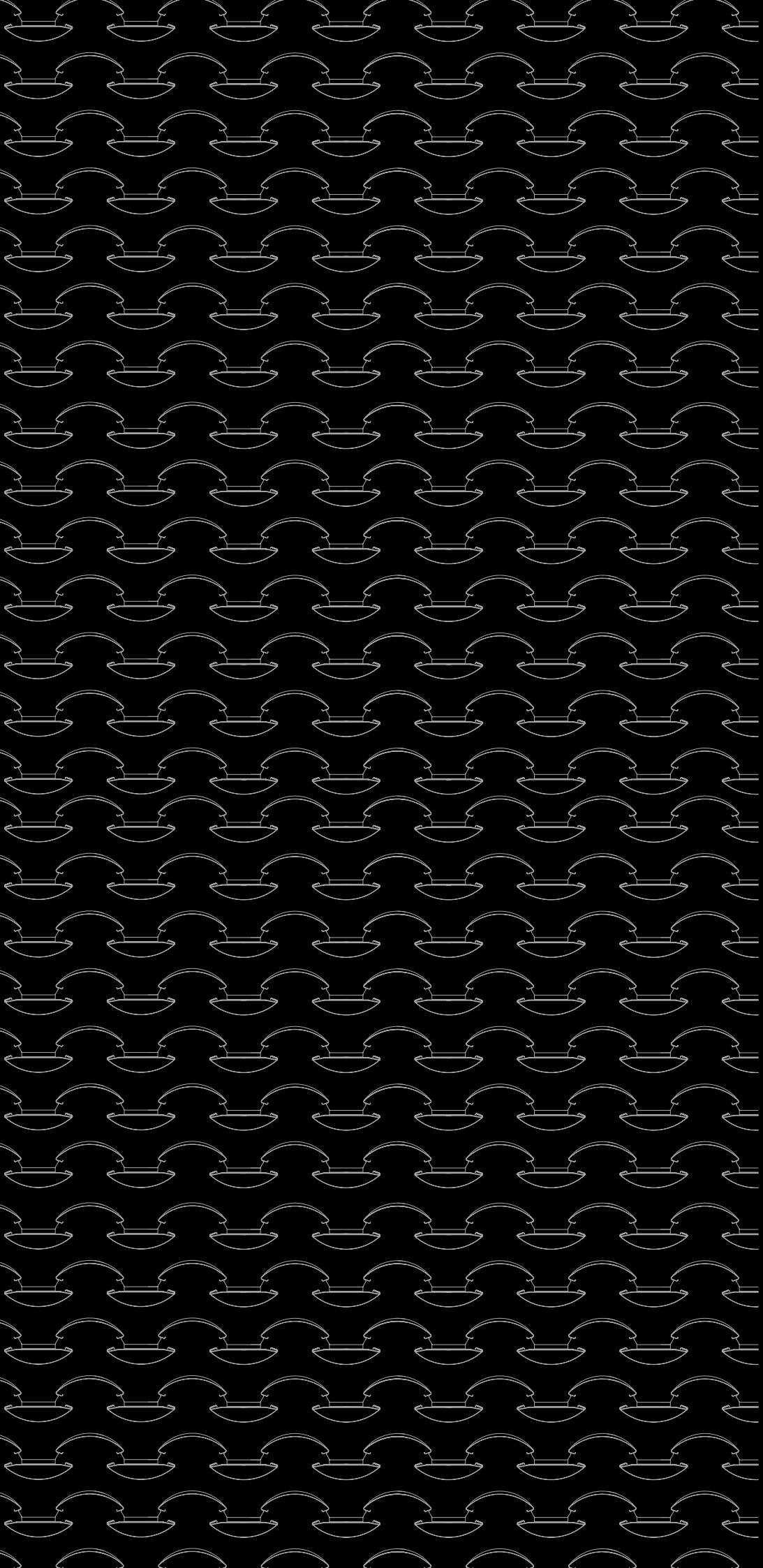

**LINEAR SUNSLOUVRES**

# AEROBRISE | QUADROBRISE



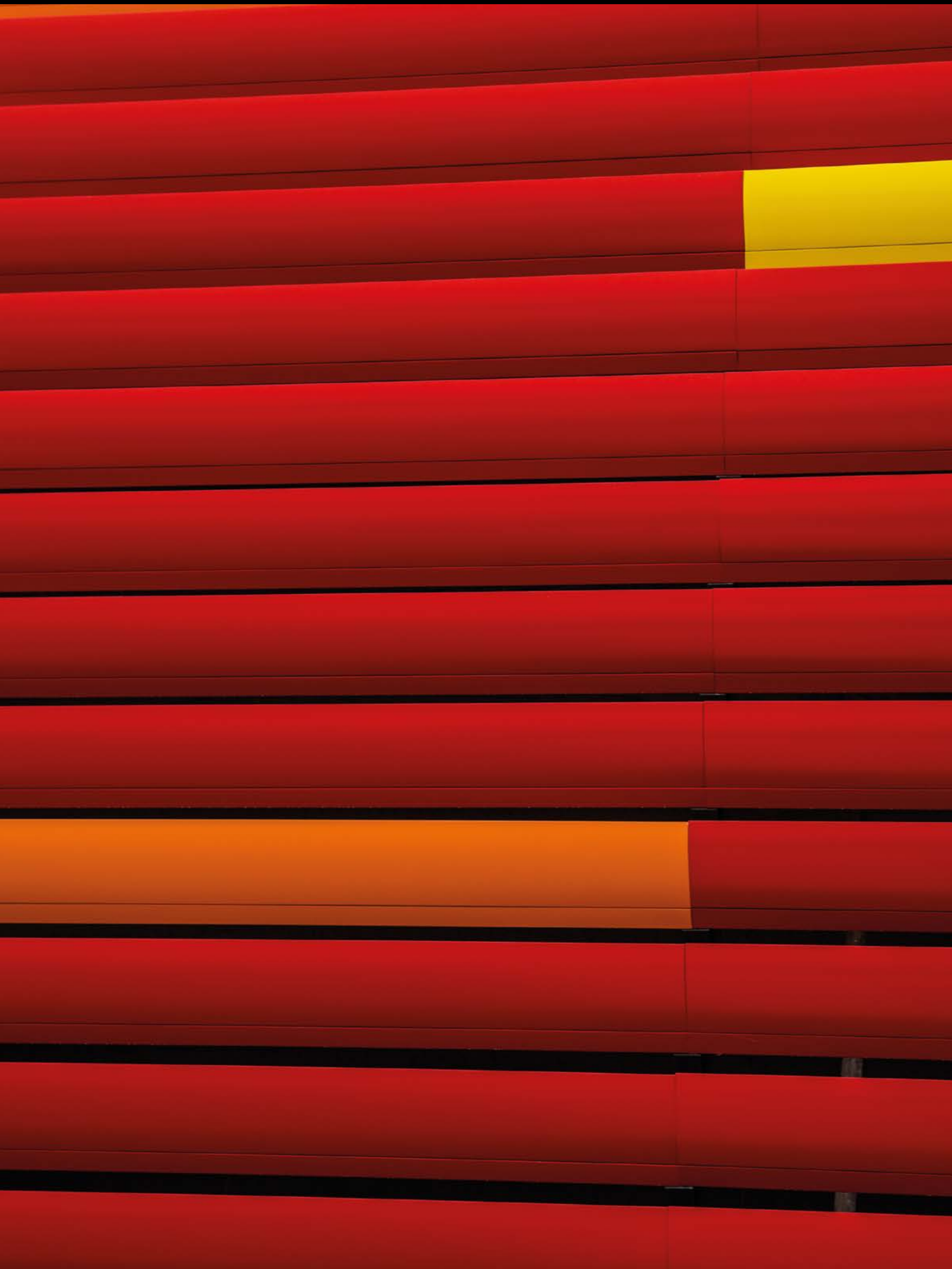

# AEROBRISE | QUADROBRISE

Solar Control | Linear sunlouvers



The Aerobrise and Quadrobrise louvers have been created to be used for any type of façade, including walls, curtains, wall coverings and staircases. The panel is fixed directly to the structure, so the spacing varies. This makes it possible to control the façades' transparency. The panels can be installed vertically or horizontally depending on the design and at any angle. The panels have endcaps on their ends as accessories, which provides an excellent finish from all views. Due to their low weight, these panels can be used for any type of structure with a minimum load, allowing their use on both new and reused façades. One of the Quadrobrise characteristics is that it looks the same from the inside and the outside because it is a closed rectangular panel.

## AEROBRISE



### AEROBRISE 100

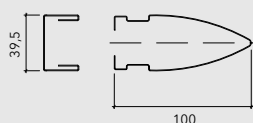

### AEROBRISE 100 ENDCAP

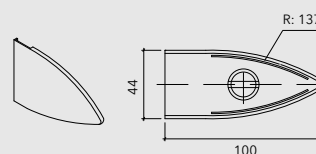

### AEROBRISE 200

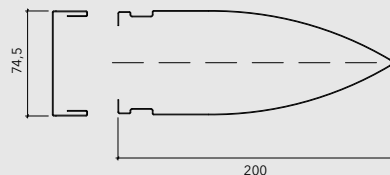

### AEROBRISE 200 ENDCAP

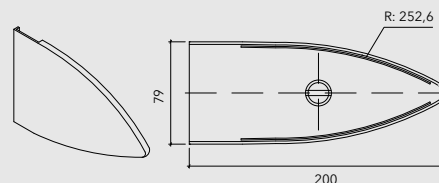

## TECHNICAL DESCRIPTION

### AEROBRISE 100/200 COMPONENTS

PRODUCT	MATERIAL	THICKNESS (mm)	WEIGHT (kg/m <sup>2</sup> )	WEIGHT (kg/ml)	MAXIMUM LENGTH	STANDARD PITCH
AEROBRISE 100	ZINC ALUME	0,5	18,4	1,42	6000	77 mm
AEROBRISE 200		0,6	16	2,37		148 mm

Note: Weight per m<sup>2</sup> calculated with Aerobrise plus fastener bolt in zinc-aluminum considering standard axis measurements.

- Colors: Available in over 100 standard colors and in custom colors
- Finish: Smooth or perforated, Wood or Mineralgrains
- Uses: Louver and ceiling
- Other materials available: Weathering steel, aluminum, copper and zinc



## ASSEMBLY

Assembly is simple because this panel is installed directly onto the structure. It includes a fastener bolt that allows for finishings to be concealed.

## AEROBRISE INSTALLATION

### GENERAL AEROBRISE 100/200 SYSTEM HORIZONTAL

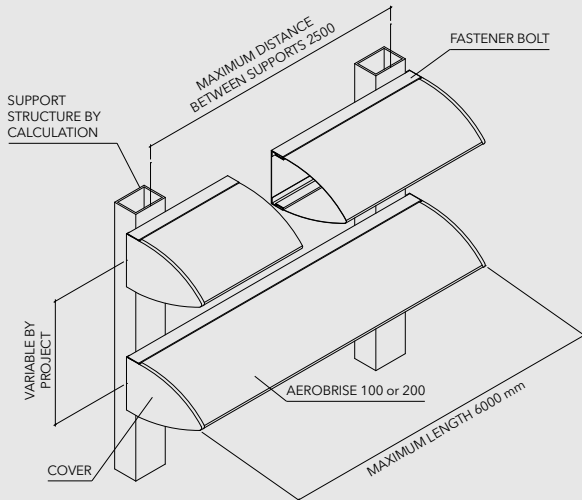

### VERTICAL AEROBRISE 100/200 SYSTEM VERTICAL APPLICATION

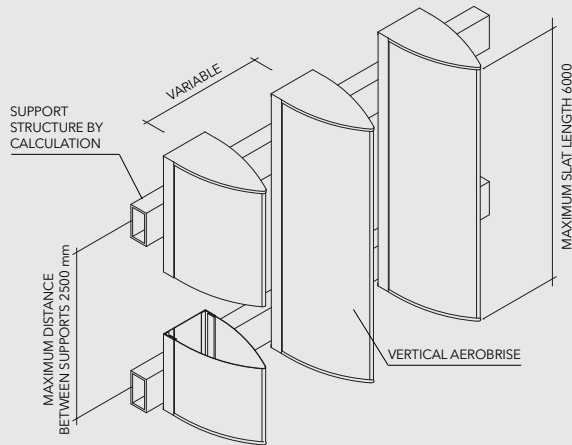

SUPPORTING PROFILE  
MATERIAL: ZINC ALUMINUM  
THICKNESS: 0,6 mm

AEROBRISE PANEL  
MATERIAL: ZINC ALUMINUM  
THICKNESS: 0,5 AND 0,6 mm

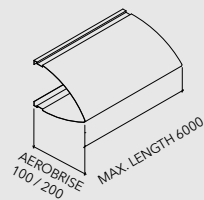
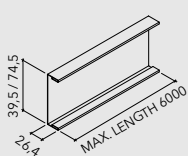

### AEROBRISE 100 DETAIL HORIZONTAL INSIDE OPENING

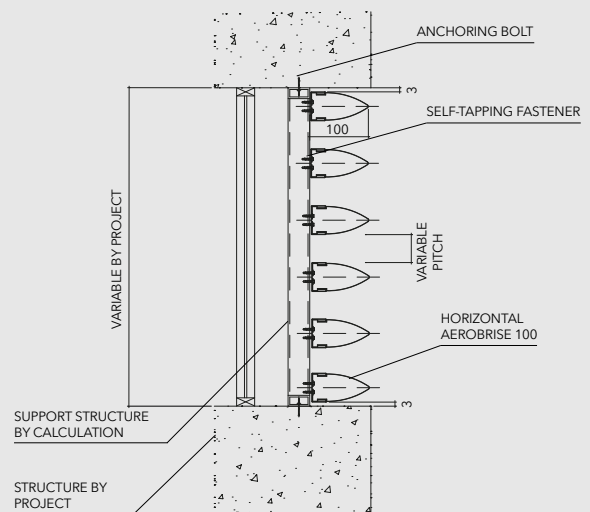

### AEROBRISE CENTAL APPLICATION DETAIL

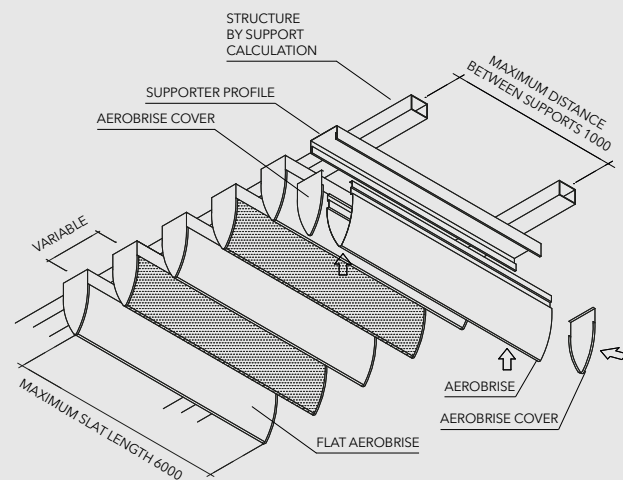

Note: Silicone should be applied for the installation of the Aerobrise cover in order to ensure that it does not come off.

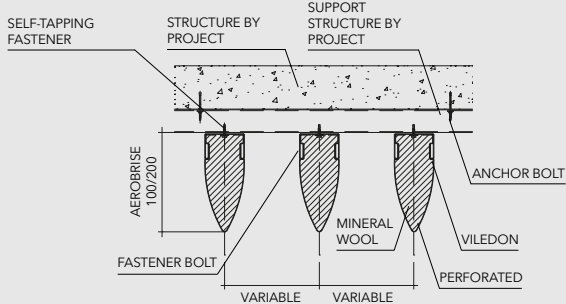

# AEROBRISE | QUADROBRISE

Solar Control | Linear sunlouvers



QUADROBRISE 25/50

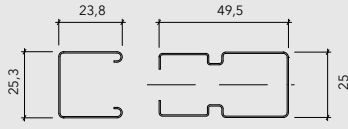

END CAPS

QUADROBRISE 25/50

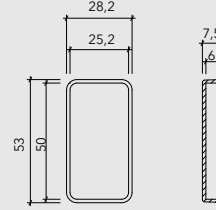

QUADROBRISE 25/75

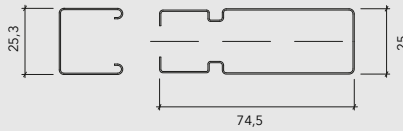

Material: aluminium

QUADROBRISE 25/75

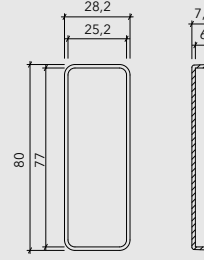

Material: aluminium

QUADROBRISE 40/60

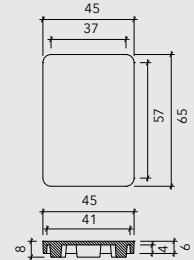

Material: aluminium and zinc - aluminium

QUADROBRISE 40/60

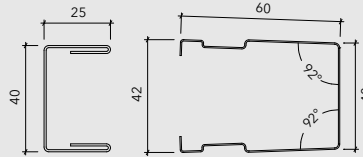

QUADROBRISE 25/50 - 25/75 - 40/60 COMPONENTS

QUADROBRISE	MATERIAL	THICKNESS (mm)	WEIGHT (kg/ml)	WEIGHT (kg/m <sup>2</sup> )	MAXIMUM LENGTH	STANDARD PITCH
25 / 50	ZINCALUME	0,5	0,9	17,7	6000	50 mm
		0,6	1,1	21,2		
	ALUMINIUM	0,7	0,4	7,3		
		0,5	1,1	21,6		
25 / 75	ZINCALUME	0,6	1,3	25,9		
		0,7	0,4	8,0		
	ALUMINIUM	0,5	1,1	14,4		
		0,6	1,4	17,2		
40 / 60	ZINCALUME	0,6	0,5	5,9		
		0,7	0,6	6,9		
	ALUMINIUM					

Note: Weight per m<sup>2</sup> calculated with Aerobrise plus fastener bolt in zinc-aluminum considering standard axis measurements.

QUADROBRISE 25/75 INSIDE OPENING

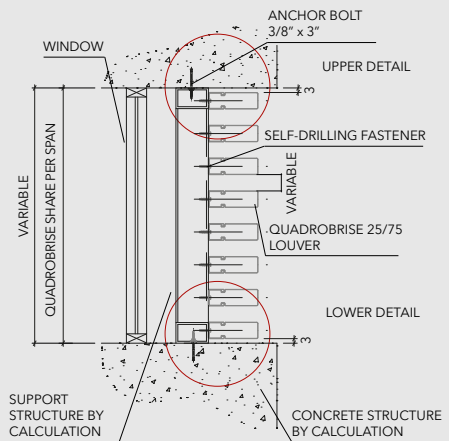

LOWER DETAIL

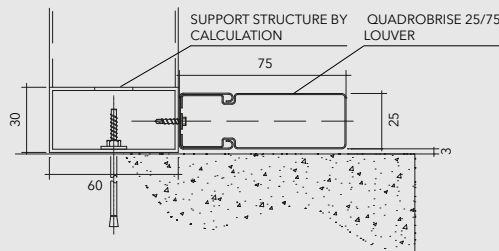

UPPER DETAIL

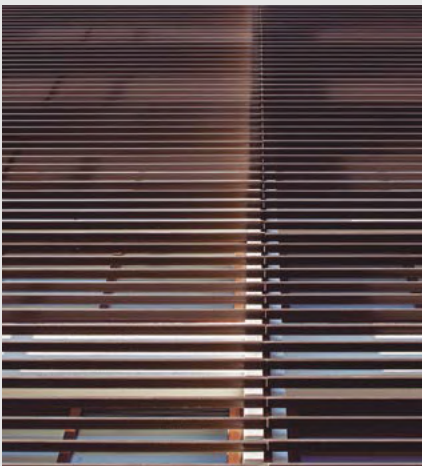
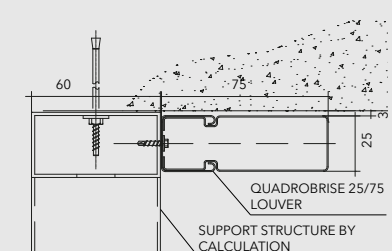

## QUADROBRISE INSTALLATION

### GENERAL QUADROBRISE 25/75 SYSTEM

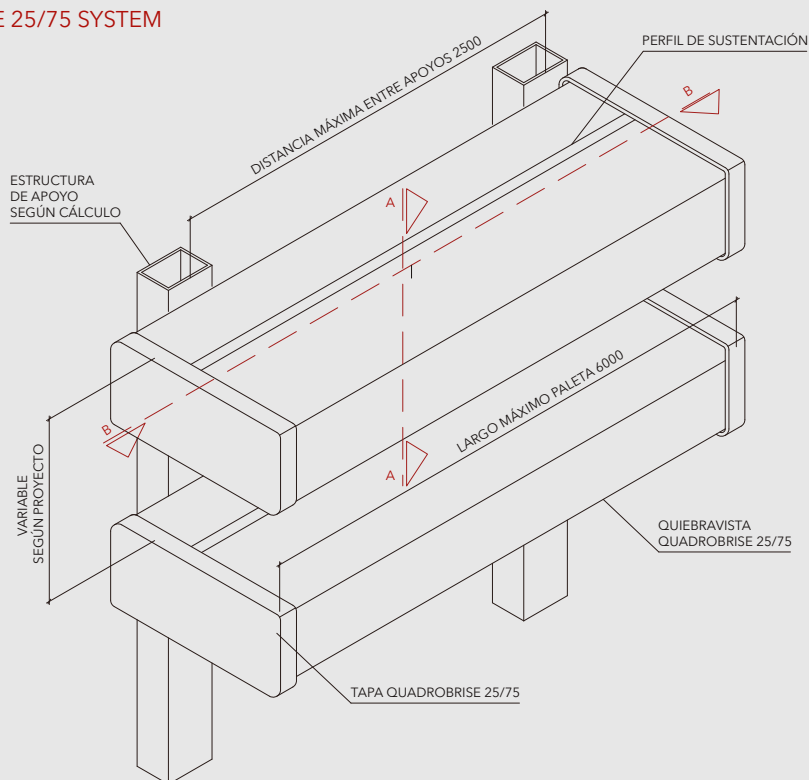

### QUADROBRISE 25/75- 25/59 A-A CROSS VIEW

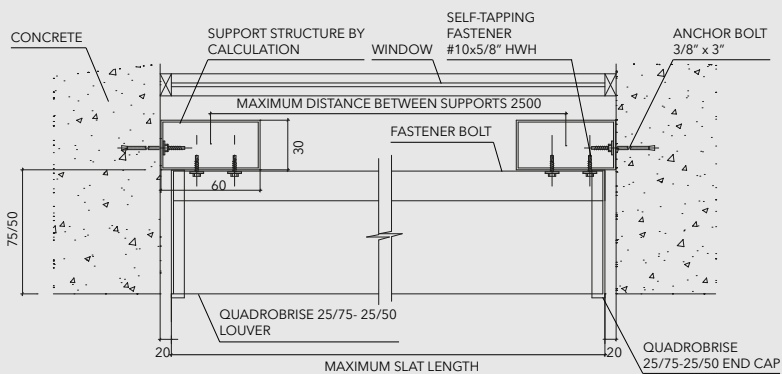

### QUADROBRISE 25/75- 25/50 CEILING APPLICATION B-B CROSS VIEW

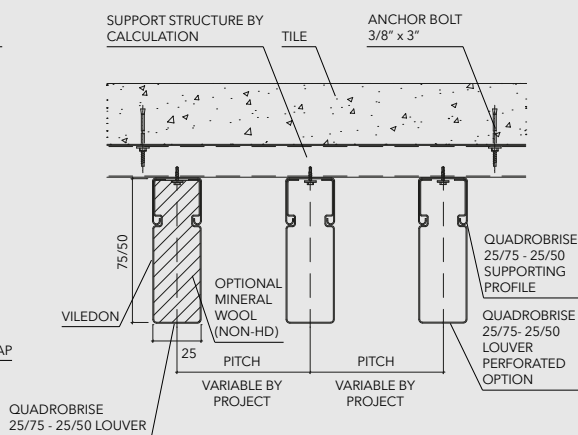

### QUADROBRISE 25/75- 25/50 DETAIL CENTAL APPLICATION

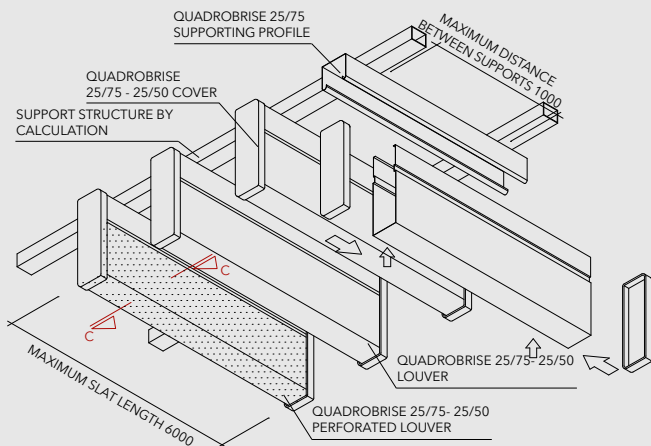

### SLIDING SHUTTERS SYSTEM

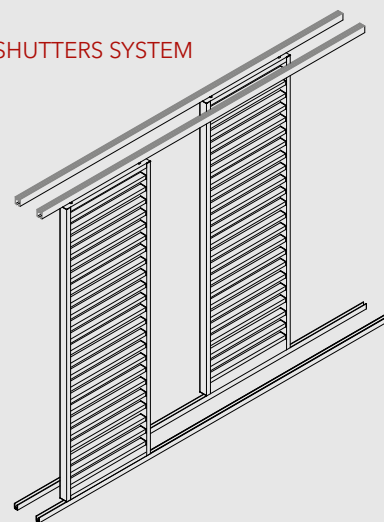

# CELOSCREEN







# CELOSCREEN

Solar Control | Linear sunlouvers



The Celoscreen louver is a passive sun control solution composed of panel carrier profiles and pre-painted unperforated or perforated zinc-aluminum panels. The panel carrier alternatives allow the product to be adjusted to different spacings based on the technical and design requirements for each project. This product is very useful for spaces that are allocated for the exchange of air and vision control both on vertical walls and curtain walls and residential building loggias or as an overhead sunshade. The Celoscreen louver is an application that allows for contrast with plain wall finishings or can be used in combination with another type of finishing.

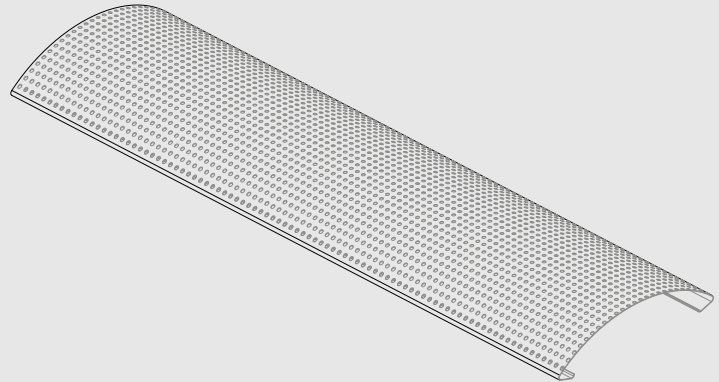
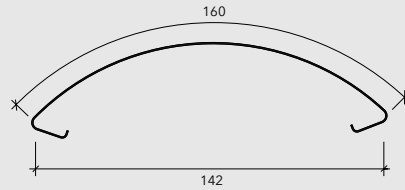

## TECHNICAL DESCRIPTION

CELOSCREEN	MATERIAL	THICKNESS (mm)	WEIGHT (kg/m <sup>2</sup> )	YIELD (m <sup>2</sup> /m <sup>2</sup> )
110	ZINC-ALUMINUM	0,5	6,8	9,09
	ALUMINUM	0,8	3,7	
120	ZINC-ALUMINUM	0,5	6,2	8,33
	ALUMINUM	0,8	3,4	
150	ZINC-ALUMINUM	0,5	5,0	6,67
	ALUMINUM	0,8	2,7	
175	ZINC-ALUMINUM	0,5	4,3	5,71
	ALUMINUM	0,8	2,3	
200	ZINC-ALUMINUM	0,5	3,7	5,00
	ALUMINUM	0,8	2,1	

- Colors: Available in over 100 standard colors and in custom colors
- Finish: Smooth or perforated, wood or mineral grain
- Uses: Louver and skylight sunshade
- Maximum length: Varies by project. We recommend that it does not exceed 10 m
- Other materials available: Weathering steel, aluminum, copper and zinc

## ASSEMBLY

The Celoscreen louver is composed of panels that are installed using a precision system on panel carrier profiles with five different spacings: 110, 120, 150, 175 and 200 mm, which provides various opening options in order to obtain adequate sun protection. The panels can be installed vertically, horizontally or on inclined surfaces.

## INSTALLATION

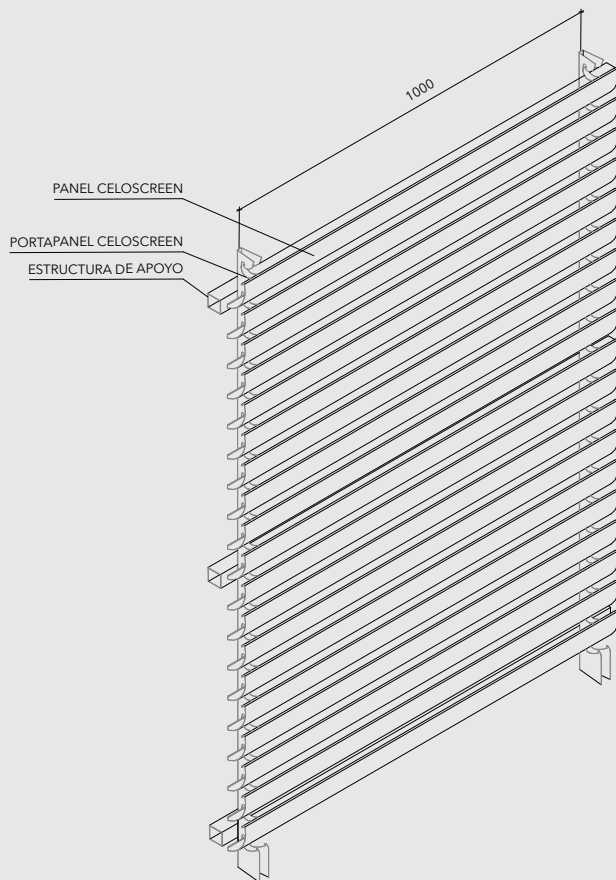

### CELOSREEN PANEL CARRIER

#### 110 PITCH

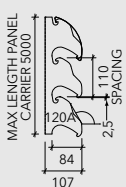

#### 120 PITCH

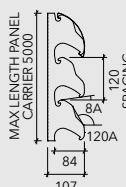

#### 150 PITCH

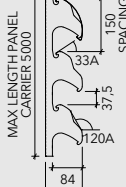

#### 175 PITCH

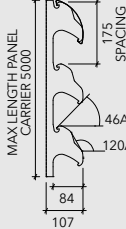

#### 200 PITCH

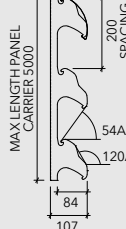

### INSTALLATION OPTIONS

#### APPLICATION INSIDE OF SPAN

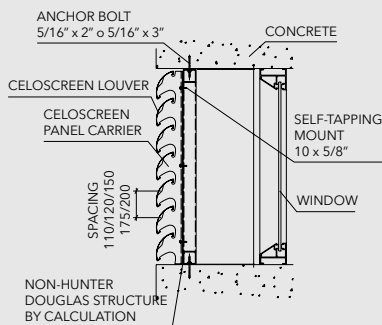

#### OVERHEAD SUNSCREEN APPLICATION

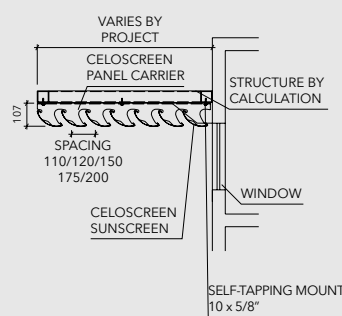

### STANDARD PERFORATIONS

# 103	# 106	# 110-M1	# 110-M3	# 118	# 118 M2
Ø 3 mm	Ø 2,5 mm	Ø 3,9 mm	Ø 3,9 mm	Ø 2 mm	Ø 2 mm
20% open	16% open	21% open	21% open	15% open	7,3% open
6,35 mm	5,5 mm	9,53 mm	9,53 mm	8,6 mm	3 mm
5,5 mm	5,5 mm	8,25 mm	11 mm	5 mm	6,6 mm

Note: The components of this product are constantly being improved and developed, so modifications may be made. The measurements listed on this Technical Sheet are expressed in millimeters (mm). In order to ensure that the product works correctly, the installation should always be handled by an authorized distributor using all of the accessories listed and in accordance with Hunter Douglas technical specifications.





# SUNLINES

Solar Control | Linear sunlouvers

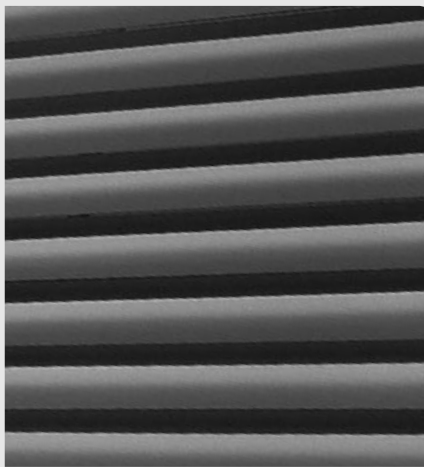

The Sunlines panel is a passive sun control solution composed of panel carriers, clips and pre-coated flat or perforated zinc-aluminum panels. Due to their configuration, they are mainly designed to be used as an overhead sunshade or louver. The lower panels act as a rainwater conductor channel, preventing water from falling directly to the floor. There is indirect sunlight transmission as a result of the reflection between the upper and lower panels, so the use of lighter colors, particularly white, is recommended.

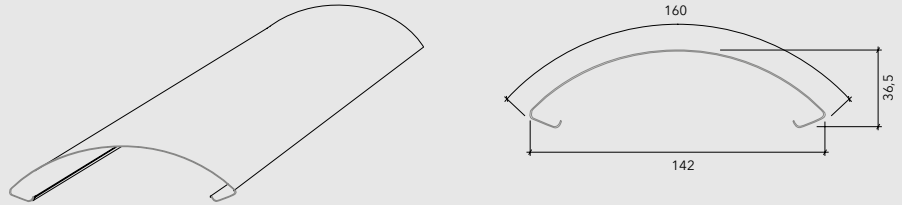

## TECHNICAL DESCRIPTION

PRODUCT	MATERIAL	THICKNESS (mm)	WEIGHT (kg/m <sup>2</sup> )	EFFICIENCY (unit/m <sup>2</sup> )
SUNLINES	ZINCALUME	0,5	12,8	9,3

- Colors: Available in over 100 standard colors and in custom colors
- Finish: Smooth or perforated, wood or mineral grain
- Uses: Louver and ceiling
- Length: Varies by project requirement. We recommend that length not exceed 6 m
- Other materials available: Weathering steel, aluminum, copper and zinc

## ASSEMBLY

The SunLines sunshade is composed of panels that are installed through a fixed pressure system on panel carrier profiles (upper panel) and through fastening clips (lower panel). This product can be installed as an overhead sunshade with a small slope to lead water towards one end of the panel.

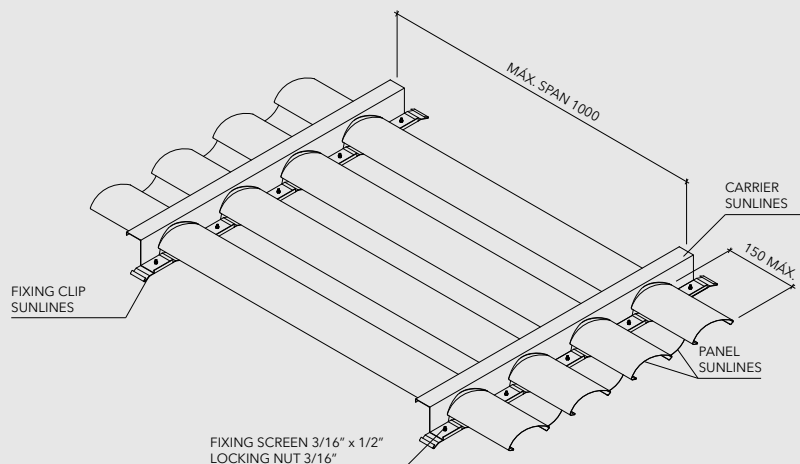

## INSTALLATION

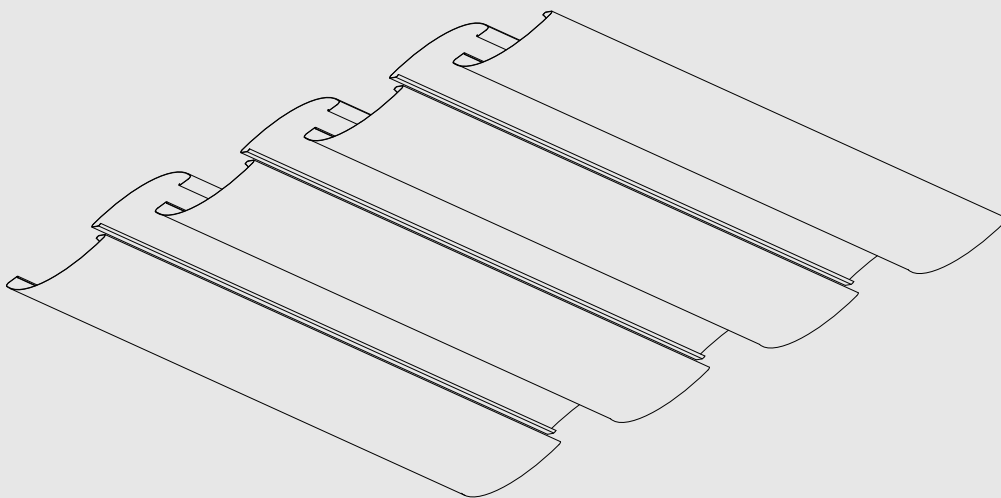

### RAIN WATER SYSTEM

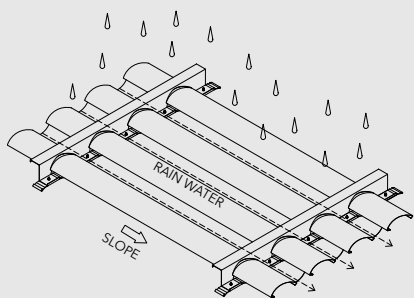

### SUNLIGHT IMPACT SYSTEM

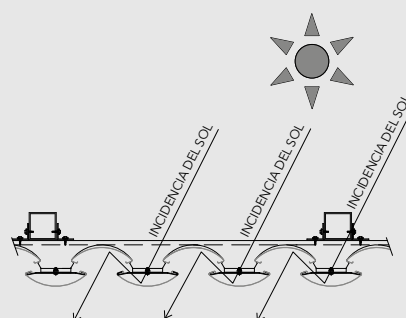

### FASTENING DIRECTLY TO STRUCTURE

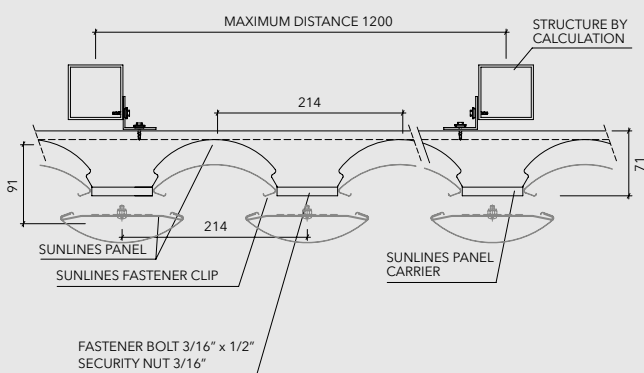

### HANGING FASTENING

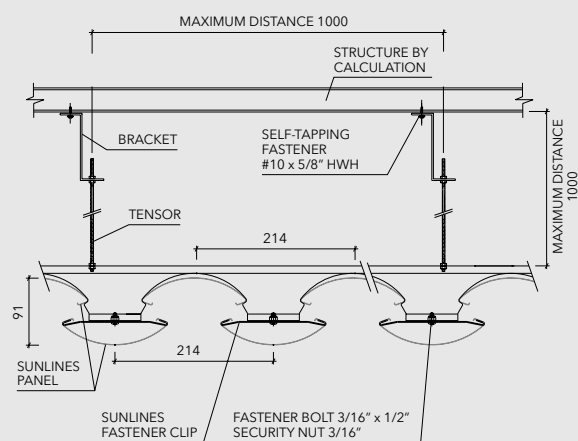

## STANDARD PERFORATIONS

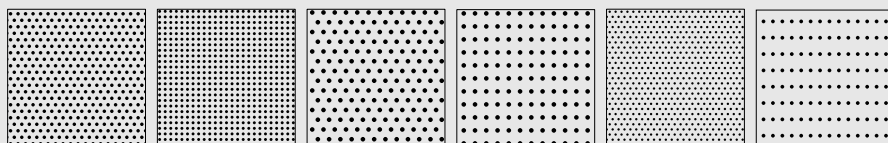

# 103	# 106	# 110-M1	# 110-M3	# 118	# 118 M2
Ø 3 mm	Ø 2,5 mm	Ø 3,9 mm	Ø 3,9 mm	Ø 2 mm	Ø 2 mm
20% open	16% open	21% open	21% open	15% open	7,3% open
6,35 mm	5,5 mm	9,53 mm	9,53 mm	8,6 mm	3 mm
5,5 mm	5,5 mm	8,25 mm	11 mm	5 mm	6,6 mm

Note: The components of this product are constantly being improved and developed, so modifications may be made. The measurements listed on this Technical Sheet are expressed in millimeters (mm). In order to ensure that the product works correctly, the installation should always be handled by an authorized distributor using all of the accessories listed and in accordance with Hunter Douglas technical specifications.

# QUIEBRAVISTA 30B-50B-50BD







# QUIEBRAVISTA 30B-50B-50BD

Solar Control | Linear sunlouvers



Louvres composed by u-shaped stove-enameled zinc-aluminum panels with variable spacing depending on the project requirements. This is an architectural element that uses linear panels with thin modulation, and is especially made for lattice-work solutions, façade spans, loggias, staircases, roofs and eaves. This light-weight product is ideal for façade renovations.

30B LOUVER

50 B LOUVER

50 BD LOUVER

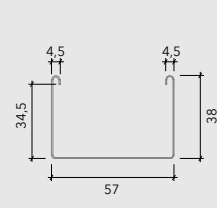
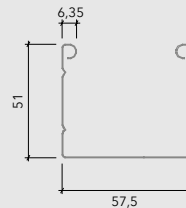
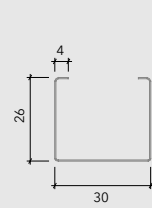
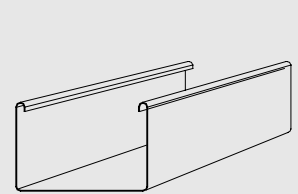
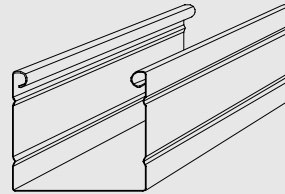
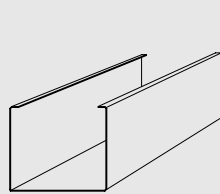

## TECHNICAL DESCRIPTION

PRODUCT	MATERIAL	THICKNESS (mm)	WEIGHT (kg/m <sup>2</sup> )	PITCH (mm)	EFFICIENCY (panels/m <sup>2</sup> )
30B	ZINCALUME	0,5	10,75	60	16,7
		0,6	12,1		
50B		0,5	11,1	115	8,7
		0,6	12,1		
50BD		0,5	9,5	114	8,8
		0,5	10,7		

Note: Weight only includes louver and panel carrier. The separation between the axes and the partition may vary depending on the project.

- Colors: Available in over 100 standard colors and in custom colors
- Finish: Smooth or perforated, wood or mineral grain
- Uses: Louver and ceiling
- Length: Varies by project requirement. We recommend that length not exceed 6 m
- Other materials available: Weathering steel, aluminum, copper and zinc

## ASSEMBLY

The 30B, 50B and 50 BD louvers are installed using a locking mechanism for each pre-assembled panel with a pop rivet that keeps it from moving or vibrating. The provision of the element includes all of the components, and it can be installed on metallic or concrete structures. The 30B, 50B and 50BD louvers are supported on a ribbed support profile with variable modulation that provides separation to the panel.

## STANDARD PERFORATION

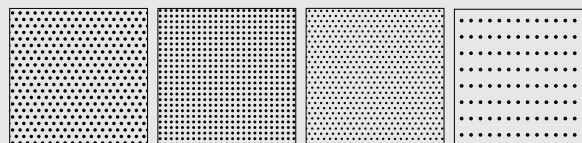

# 103	# 106	# 118	# 118 M2
Ø 3 mm	Ø 2,5 mm	Ø 2 mm	Ø 2 mm
20% abierto	16% abierto	15% abierto	7,3% abierto
6,35 mm	5,5 mm	8,6 mm	3 mm
5,5 mm	5,5 mm	5 mm	6,6 mm

## INSTALLATION

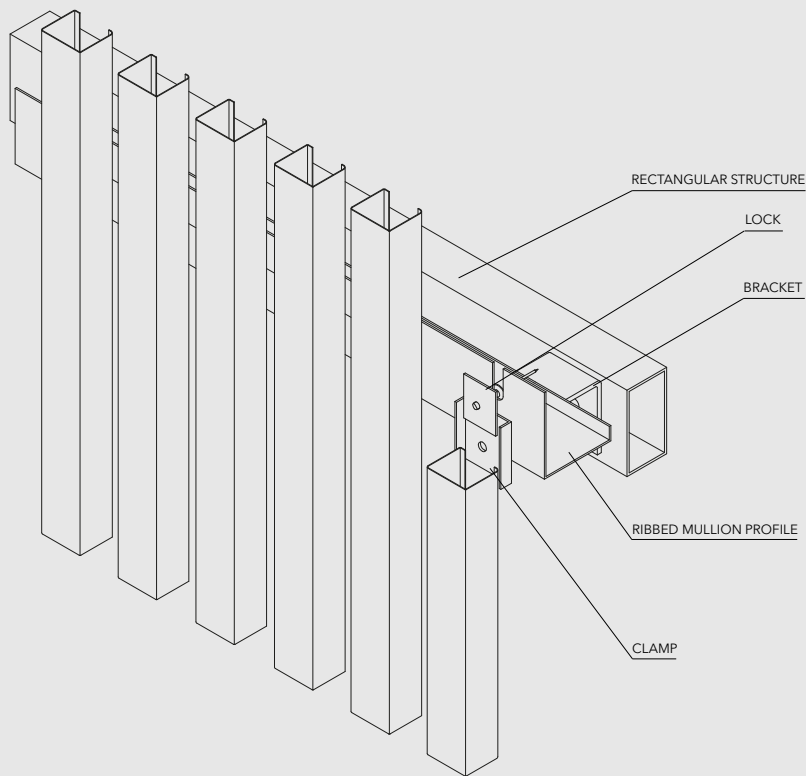

### OUTSIDE OF SPAN

### INSIDE OF SPAN

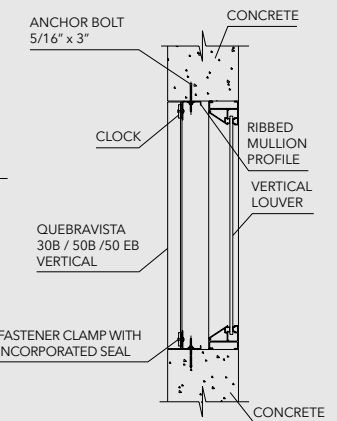
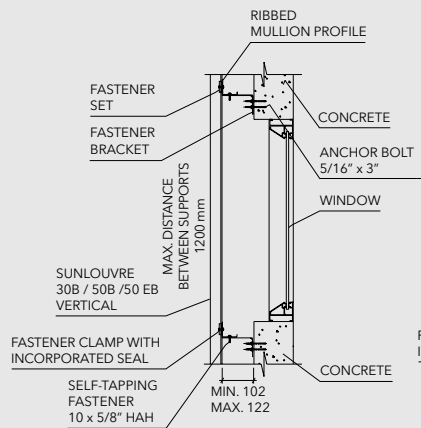
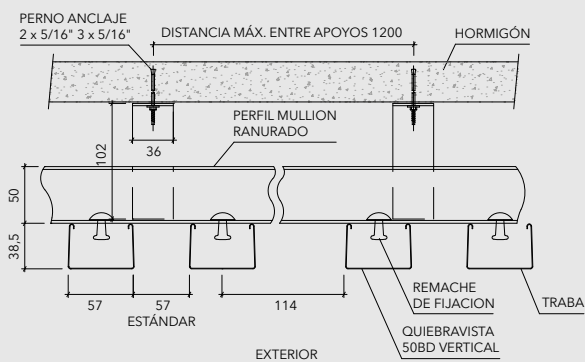

### DETAIL OF CONNECTOR

### ELEVATION

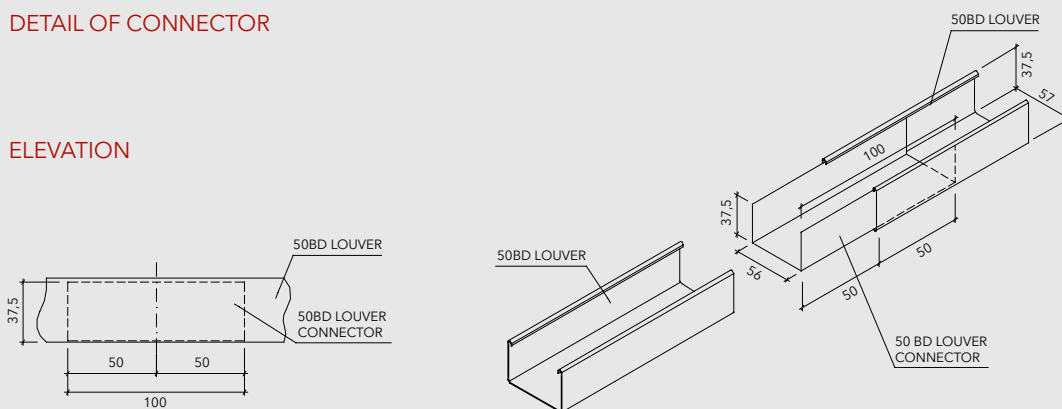

Note: The components of this product are constantly being improved and developed, so modifications may be made. The measurements listed on this Technical Sheet are expressed in millimeters (mm). In order to ensure that the product works correctly, the installation should always be handled by an authorized distributor using all of the accessories listed and in accordance with Hunter Douglas technical specifications.

# QUADRORISE 32 X 32





# QUADROBRISE 32 X 32

Solar Control | Linear sunlouvers



QuadroBrise 32 x 32 is a product designed to be used as a sunlouver or on any type of façade, including curtain walls, wall coverings, stairways and ceilings. The profiles can be installed vertically or horizontally. The system is composed of a fastener profile, a square section panel and its covers, an L bracket and a Z bar. One of the characteristics of this louver is that it has the same appearance from inside and outside. It also can be installed directly to any structure with special carriers.

## COMPONENTS

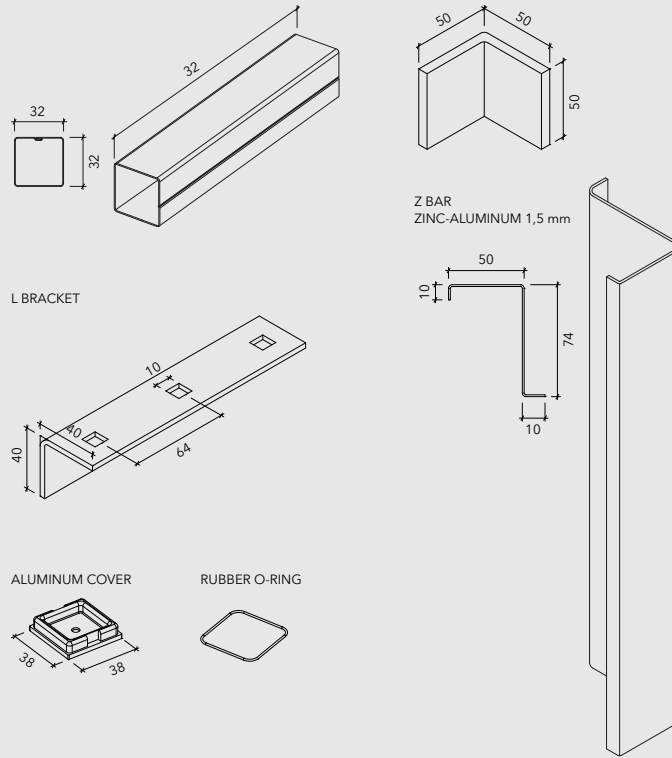

## TECHNICAL DESCRIPTION

- Material: Zinc-aluminum
- Use: Louver, ceiling and covering
- Finishing: Electrostatic sandblasted or electro-enameled on paint line
- Colors: Over 100 standard colors and custom colors available
- Other available materials: Weathering steel, aluminum, copper and zinc

PRODUCT	MATERIAL	THICKNESS (mm)	WEIGHT (kg/m <sup>2</sup> )	MAXIMUM LENGTH (mm)
QUADROBRISE 32 x 32	ZINCALUME	0,6	10,75	6000
	ALUMINIO	0,6	3,83	

Note: Weight only includes the Quadrobrise 32 x 32.

## QUADROBRISE 32 X 32 SET WITH LEVELING STRUCTURE

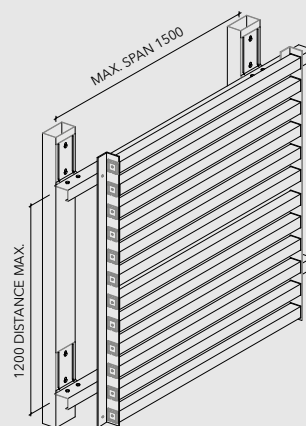

## CROSS SECTION

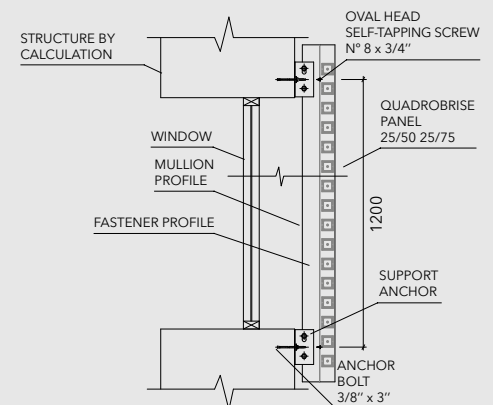

## INSTALLATION

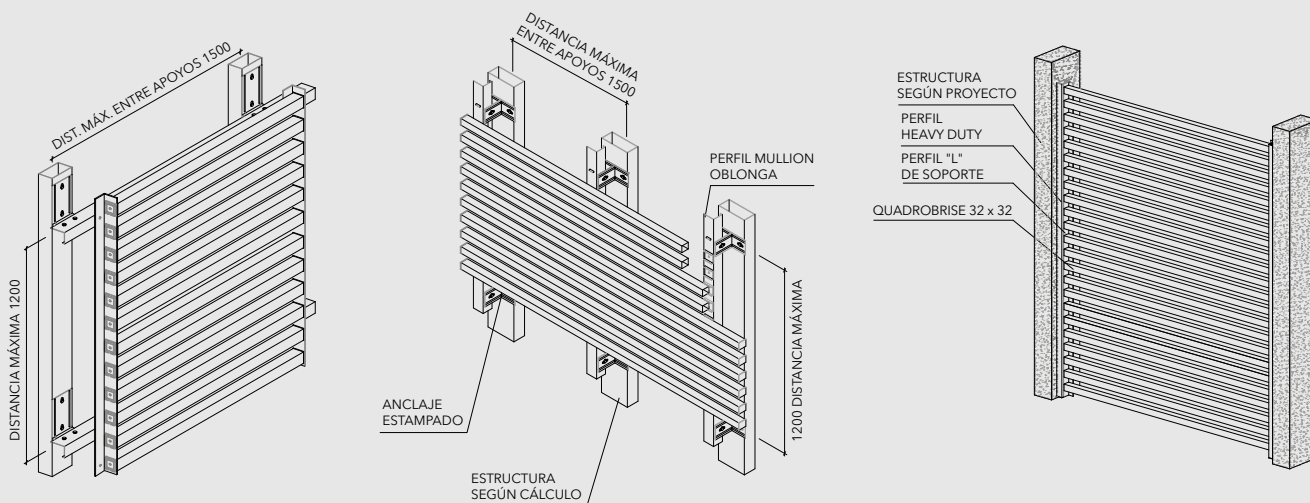

### VERTICAL INSTALLATION (FRAMED) VIEW

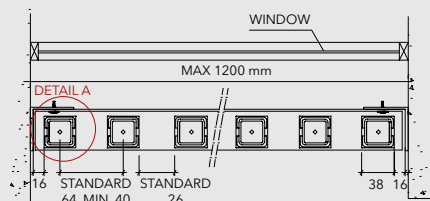

### DETAILA

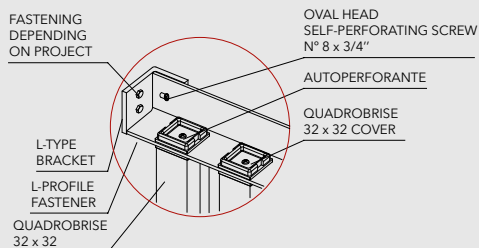

### SLIDING SHUTTERS SYSTEM

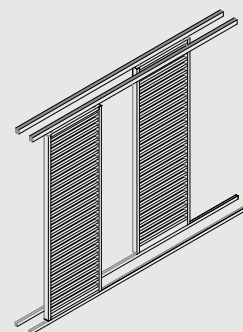

### SOLUTION WITH L-BRACKET

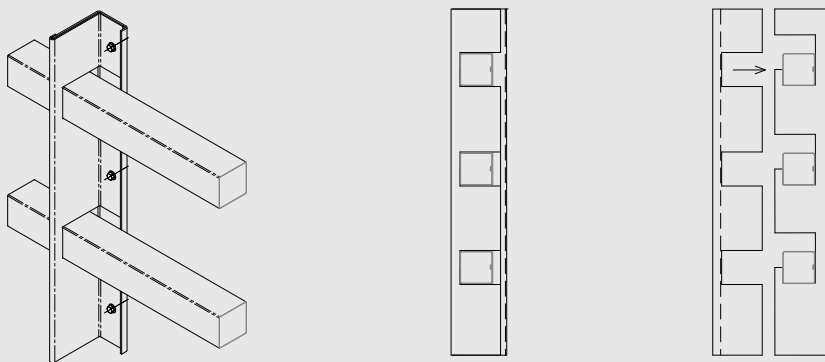

### HORIZONTAL INSTALLATION (FRAMED)

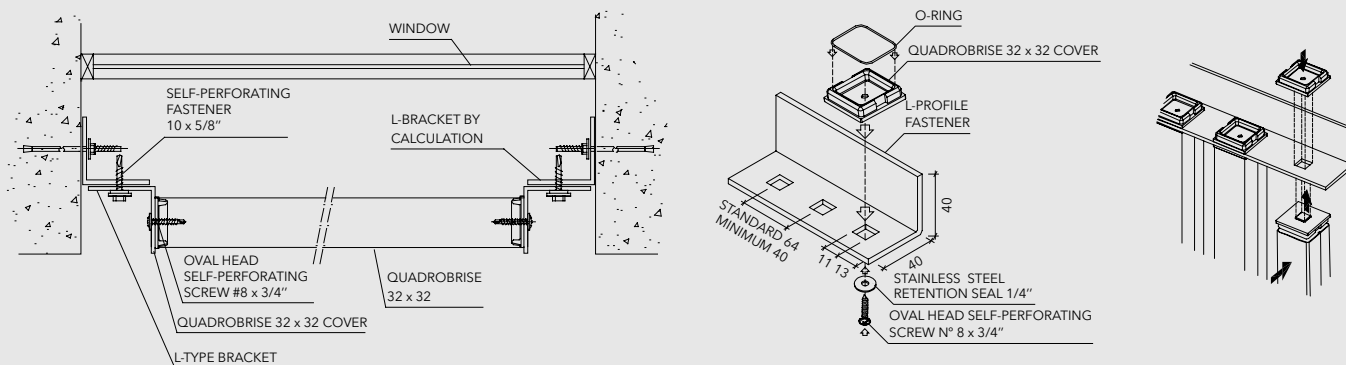

Note: The components of this product are constantly being improved and developed, so modifications may be made. The measurements listed on this Technical Sheet are expressed in millimeters (mm). In order to ensure that the product works correctly, the installation should always be handled by an authorized distributor using all of the accessories listed and in accordance with Hunter Douglas technical specifications.

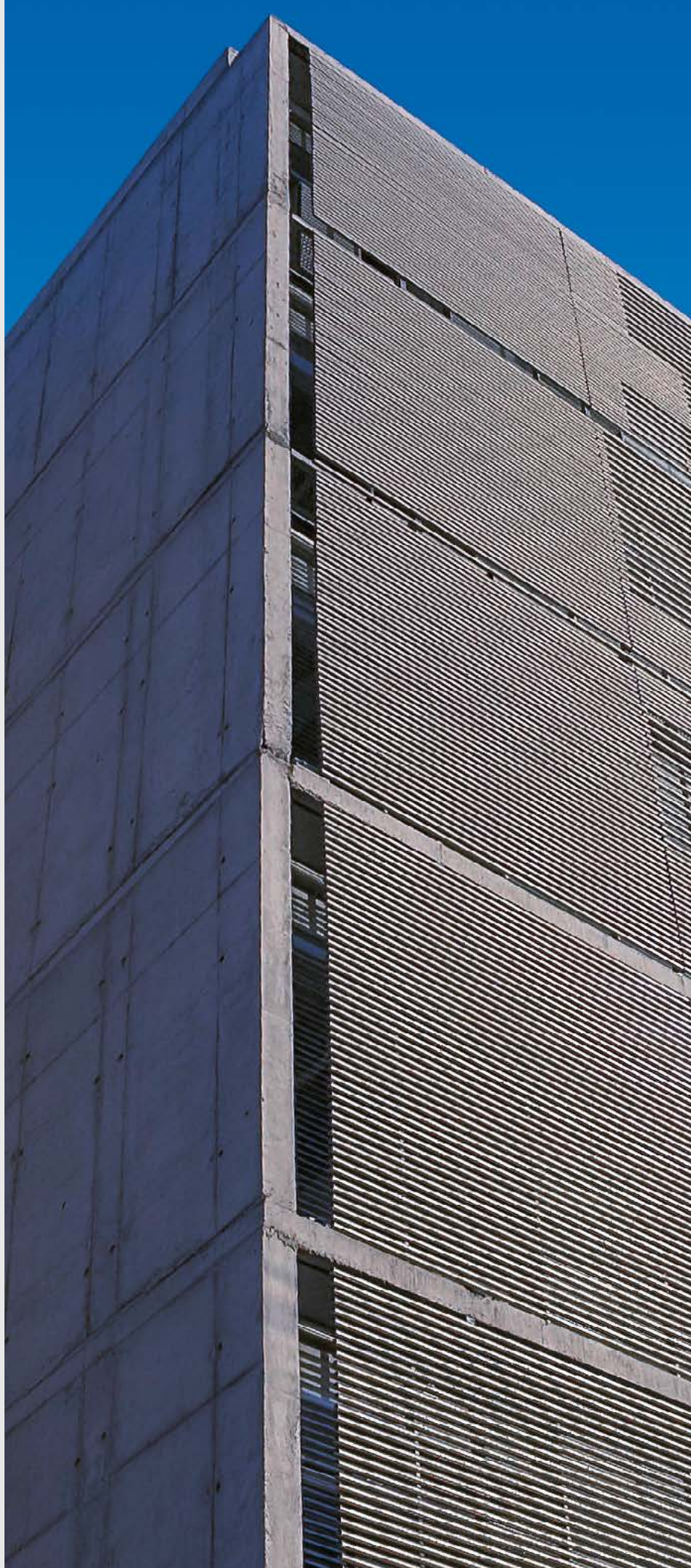





# TUBRISE

Solar Control | Linear sunlouvers



The Tubrise louver is composed of coil coated zinc-aluminum profiles with a diameter of 41 mm. The spacing can be adjusted to meet the project requirements. This is an excellent architectural element for sunscreen solutions on building façades or lattice-type work on bays, loggias, staircases, etc. The Tubrise louver can be installed with horizontal or vertical profiles. It is quick and easy to install, providing a light and attractive structural support solution. The Tubrise louver is available with flat or perforated finishes (#103 or #118). In addition, covers can be used on the ends of the tubular panels with or without shafts.

## TECHNICAL DESCRIPTION

PRODUCT	MATERIAL	THICKNESS (mm)	WEIGHT (kg/m <sup>2</sup> )	EFFICIENCY (panels/m <sup>2</sup> )	LENGTH (mm)
TUBRISE	ZINCALUME	0,4	8,78	19,6	6000
PERFORATED TUBRISE		0,5	10,58		

Note: A 51 mm pitch is considered the standard separation.

## SECTION

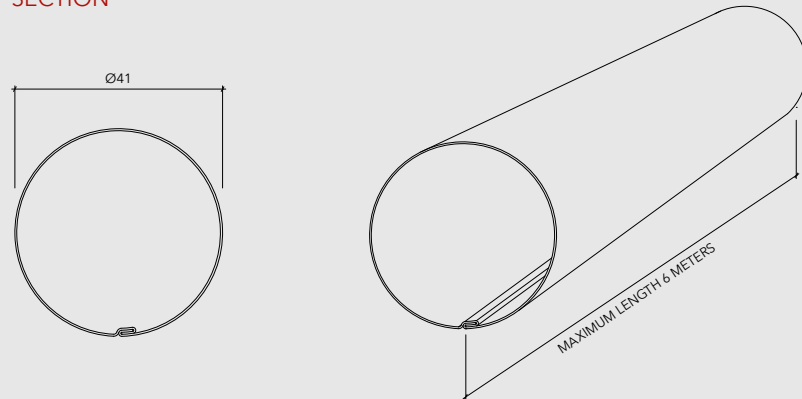

- Colors: Available in over 100 standard colors and in custom colors
- Finish: Smooth or perforated, wood or mineral grain
- Uses: Louver and ceiling
- Length: Varies by project. We recommend that it not exceed 6 m
- Other materials available: Aluminum

## ASSEMBLY

The Tubrise louver is installed on slotted support profiles with variable modulation that separate the panel based on project requirements. The panel is sustained by clips affixed using pop rivets.



## STANDARD PERFORATION

# 103	# 106	# 118	# 118 M2
Ø 3 mm	Ø 2,5 mm	Ø 2 mm	Ø 2 mm
20% open	16% open	15% open	7,3% open
6,35 mm	5,5 mm	8,6 mm	3 mm
5,5 mm	5,5 mm	5 mm	6,6 mm

## INSTALLATION

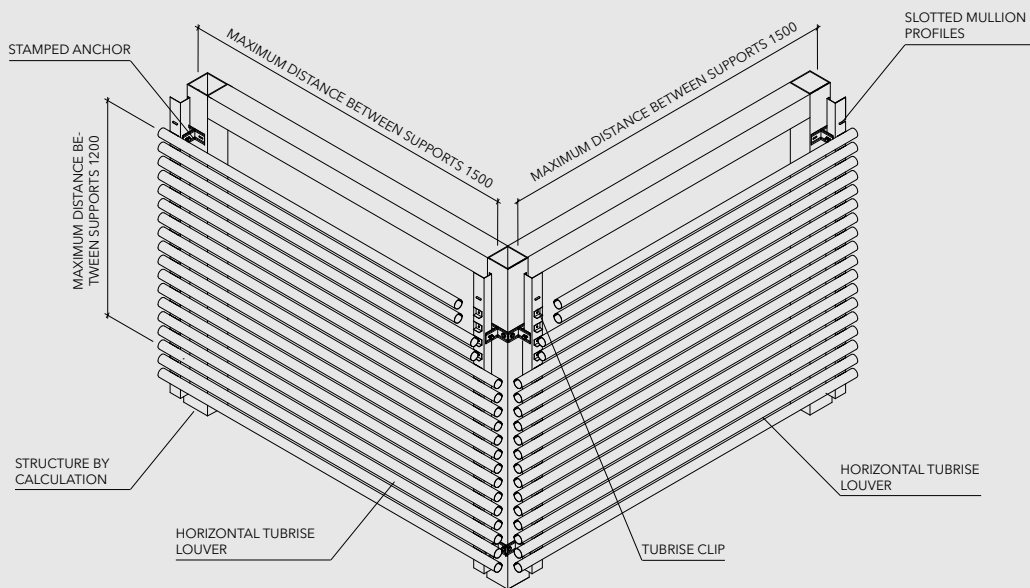

### CROSS SECTION VIEW / ISOM. VIEW

#### VERTICAL TUBRISE LOUVER

#### HORIZONTAL TUBRISE LOUVER

#### GENERAL ISOMETRIC HORIZONTAL TUBRISE SET WITH COVERS WITH AXES

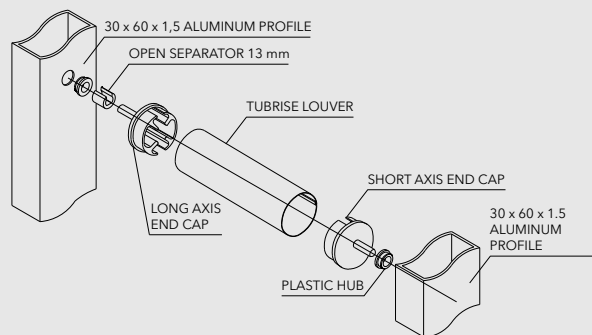
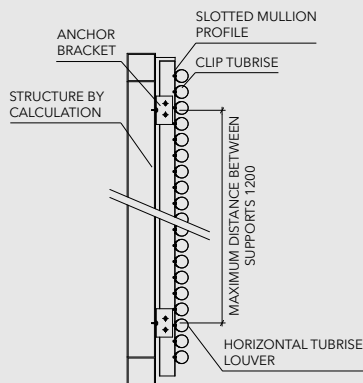
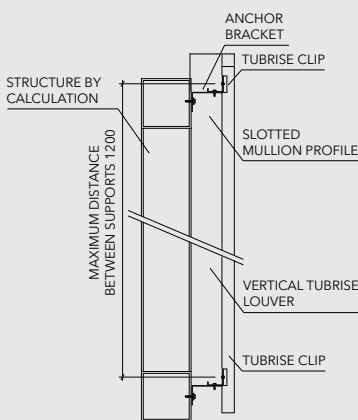

### DISTANCING AT EDGES FOR A FRAMED INSTALLATION

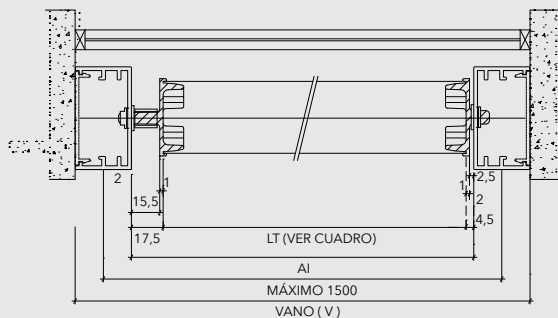

TUBRISE LENGTH
LT: AI - 22

Note: The components of this product are constantly being improved and developed, so modifications may be made. The measurements listed on this Technical Sheet are expressed in millimeters (mm). In order to ensure that the product works correctly, the installation should always be handled by an authorized distributor using all of the accessories listed and in accordance with Hunter Douglas technical specifications.

# MINITUBRISE

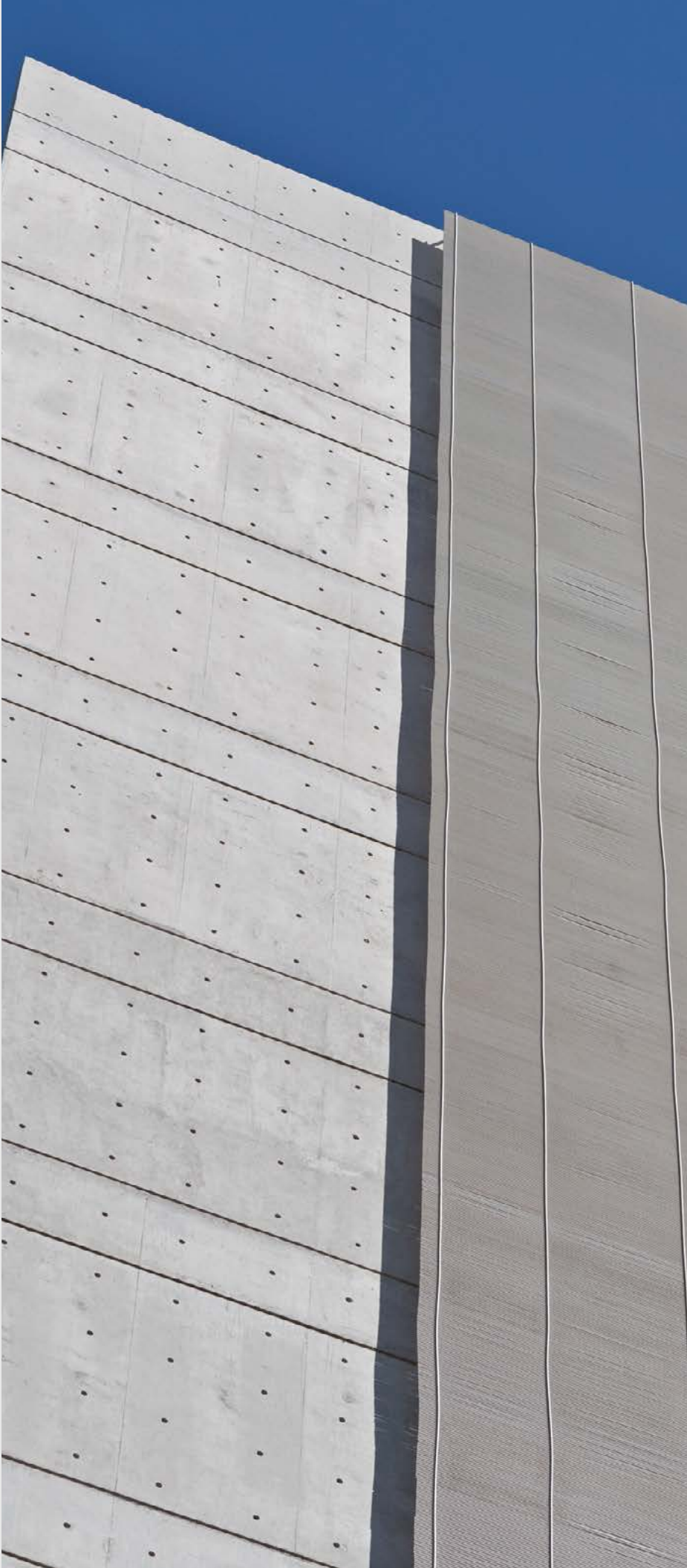



# MINITUBRISE

Solar Control | Linear sunlouvers



The Minitubrise louvre is composed of zinc-aluminum or aluminum profiles formed by a circular section with a 10 mm diameter which are hold in place by a vertical 6-mm thick aluminum panel carrier. The standard separation of the profiles formed by a circular section is 10 mm section / pitch 20 mm or others to the axis. This architectural element is especially designed for solutions such as sunscreens for building façades, lattices in bays, loggias, staircases, overhead sunscreens and even interior ceilings. It is quick and easy to install, which makes it a very light and attractive structural support solution.

## MINITUBRISE

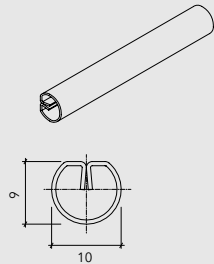

## MINITUBRISE ISOMETRIC SUPPORT

ALUMINIUM

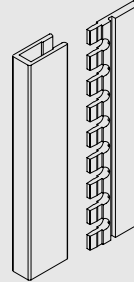

## BRACKET PROFILE

ALUMINIUM

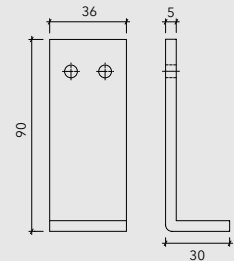

## ISOMETRIC EPDM PROFILE

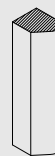

## EPDM PROFILE

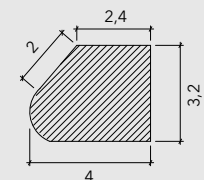

## TECHNICAL DESCRIPTION

PRODUCT	MATERIAL	THICKNESS (mm)	kg/ml	kg/m <sup>2</sup>
MINITUBRISE	ZINCALUME	0,4 mm	0,108	5,44
	ALUMINIUM	0,6 mm	0,056	2,80

- Material: Zincalume or aluminum
- Thickness: Pitch 0,4 mm or 0,6 mm
- Colors: Over 100 standard colors and custom colors available
- Uses: Louver
- Finish: Flat and woodgrains
- Measurements: Maximum length 3 meters
- Capacity: 50 profiles/ m<sup>2</sup>

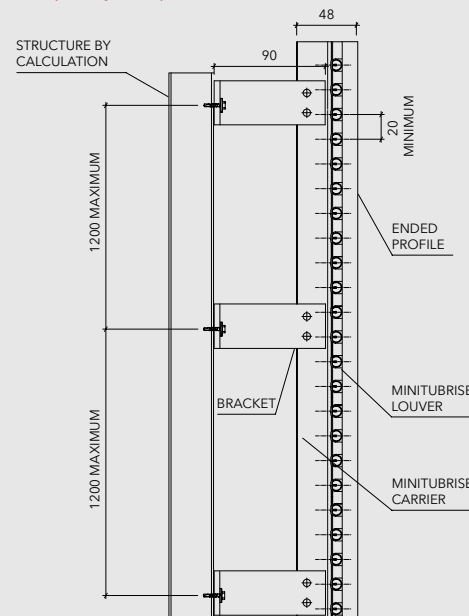

# INSTALLATION

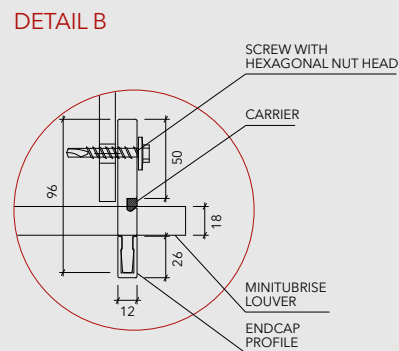
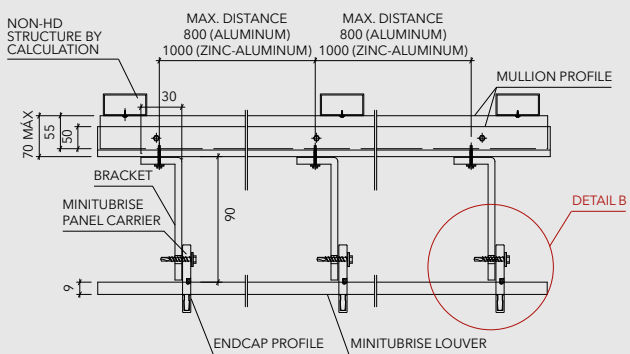
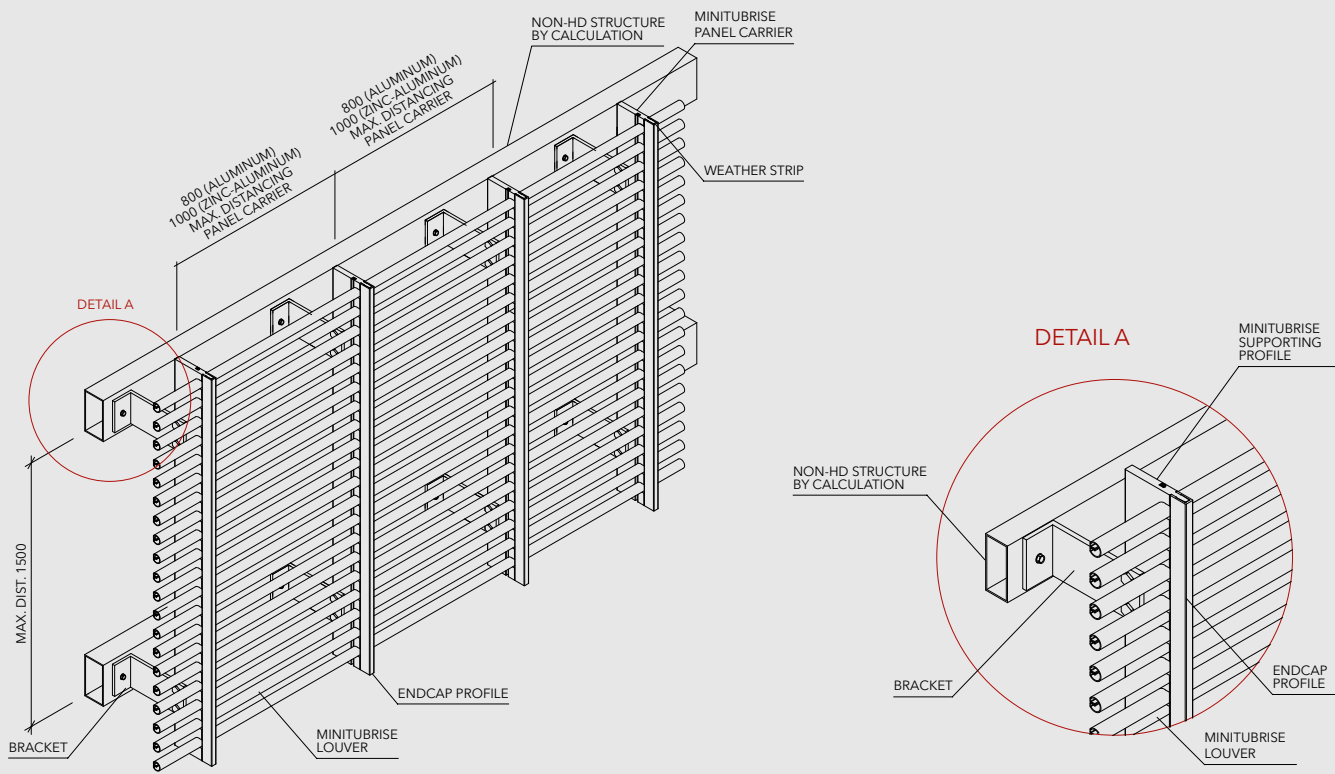

Note: The components of this product are constantly being improved and developed, so modifications may be made. The measurements listed on this Technical Sheet are expressed in millimeters (mm). In order to ensure that the product works correctly, the installation should always be handled by an authorized distributor using all of the accessories listed and in accordance with Hunter Douglas technical specifications.







# C LOUVERS

Solar Control | Linear sunlouvers

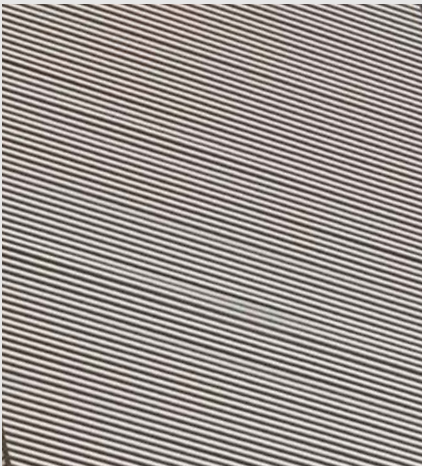

The C Lattices are formed by stove-enameled zinc-aluminum panels in a continuous line with variable separation depending on the design of the project. This product is recommended as a loggia louver and for service patios, ledges and in areas that require the exchange of air and view control built with durable materials. Due to its geometry, in addition to providing efficient sun control, this project provides more protection from water than any other lattice (C23 E and C 40 E Lattice). The strong accent of its shadows provides vigorous visual texture and the possibility of color variation allows for its use as a decorative contrast element on large surface area coverings executed with smoother material.

C23 LOUVER

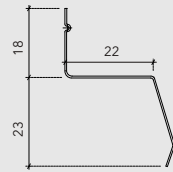

C23 E LOUVER

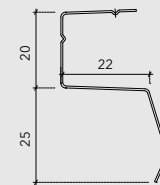

C40 LOUVER

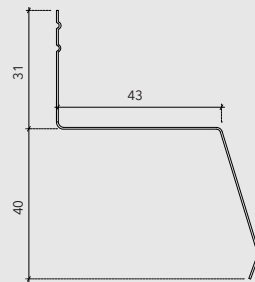

C40 E LOUVER

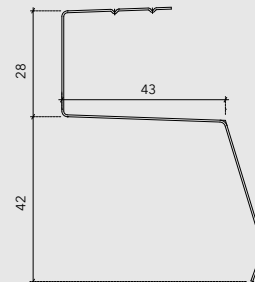

## TECHNICAL DESCRIPTION

PRODUCT	MATERIAL	THICKNESS (mm)	WEIGHT (kg/m <sup>2</sup> )	YIELD (ml/m <sup>2</sup> )	MAX. LENGTH (mm)
23 LATTICE	ZINCALUME	0,5 - 0,4	7,7	25,0	6000
40 LATTICE		0,6 - 0,5 - 0,4	7,6 - 9,1	14,1	
23 E LATTICE		0,5 - 0,4	10,8	28,6	
40 E LATTICE		0,5	11,7	16,4	

\*Standard separation to the axis is considered to be 41 mm for the C23 E lattice and 71 mm for the C 40 E lattice, respectively (without tensioner or support structure).

- Colors: Available in over 100 standard colors and in custom colors
- Finish: Smooth or perforated, wood or mineral grain
- Uses: Louvers
- Other materials available: Weathering steel, aluminum, copper and zinc
- Length: Varies by project requirement. We recommend that length does not exceed 6000 mm

## ASSEMBLY

The C23 and C40 louver with tension rod are composed of panels, spacers and tensors, creating a rigid panel that is affixed to the support structure using nuts and seals in the tensors. They can also be affixed directly to the support structure without using a tensor.

## INSTALLATION

### C23/C40 LOUVER WITH TENSION ROD

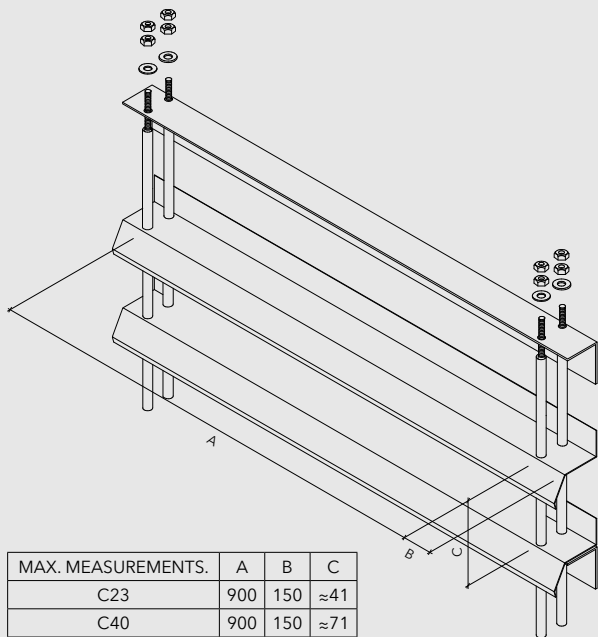

MAX. MEASUREMENTS.	A	B	C
C23	900	150	≈41
C40	900	150	≈71

### C23/C40 LOUVER DIRECTLY AFFIXED TO THE STRUCTURE

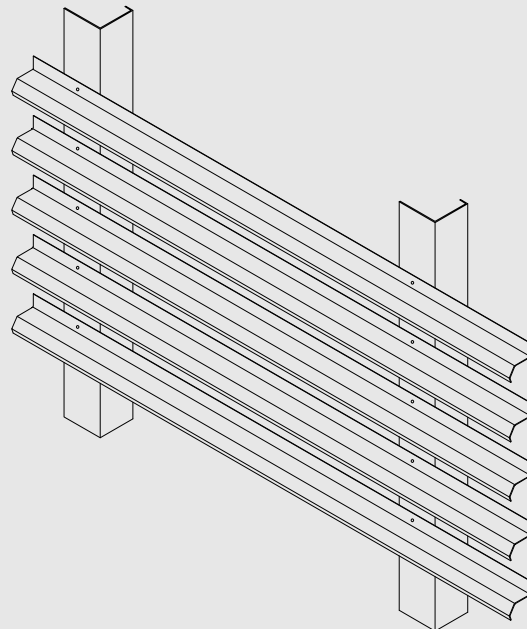

### AFFIXED DIRECTLY TO THE STRUCTURE

#### C23 E

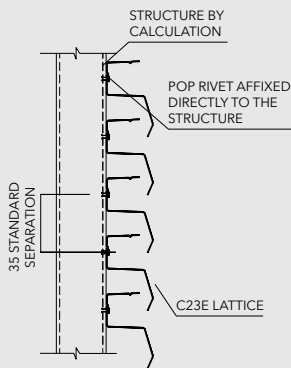

#### C40 E

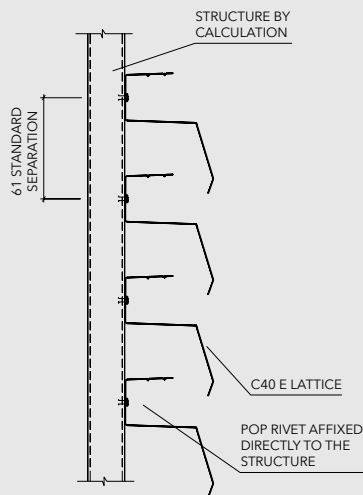

#### C23 LOUVER WITH TENSOR

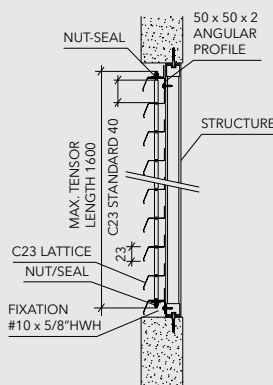

#### C 40 LOUVER WITH TENSOR

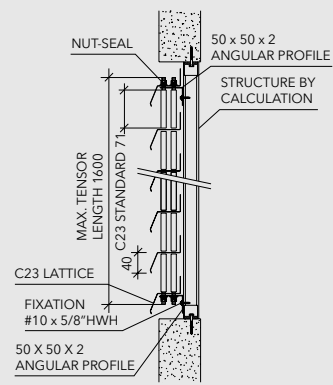

Note: C23 E and C 40 E Lattices must be affixed directly to the structure (without tensor).

### CROSECTION TENSION ROD

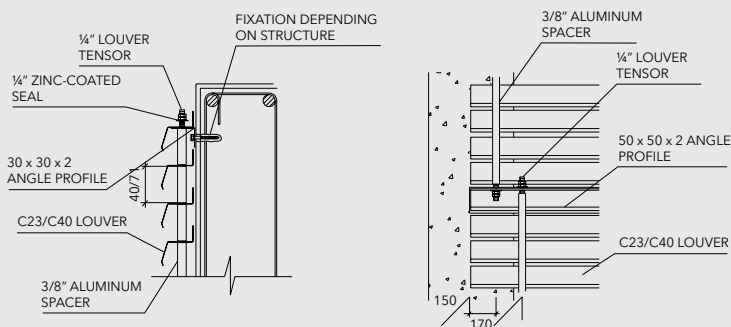

### STANDARD PERFORATIONS

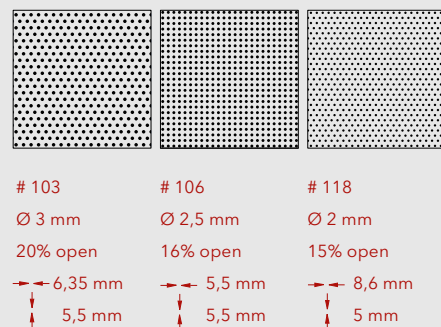

Note: The components of this product are constantly being improved and developed, so modifications may be made. The measurements listed on this Technical Sheet are expressed in millimeters (mm). In order to ensure that the product works correctly, the installation should always be handled by an authorized distributor using all of the accessories listed and in accordance with Hunter Douglas technical specifications.

# 70S SUNLOUVERS





# 70S SUNLOUVERS

Solar Control | Linear sunlouvers



The 70S Lattice is a product designed to be used in spaces that require air renewal or as a decorative element in addition to serving as a passive sun control element. This product has smooth or perforated finishing options. Given its special geometry, it generates lights and shadows that give façades character. The installation system uses anchor brackets and Hunter Douglas mullion profiles, which allows possible misalignments of the structure to be corrected. The use of the panel carrier gives the 70S Lattice a uniform appearance.

## 70S SUNLOUVERS

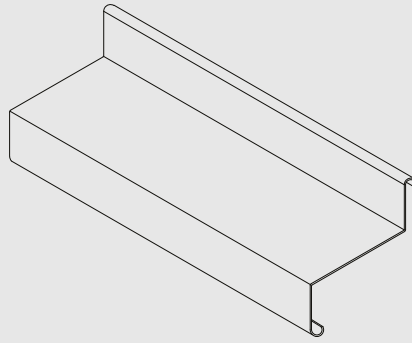

## 70S PANEL CARRIER

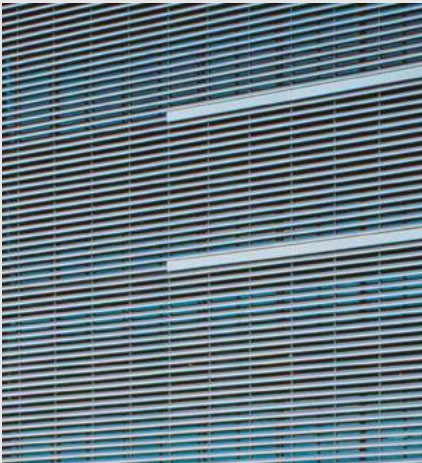
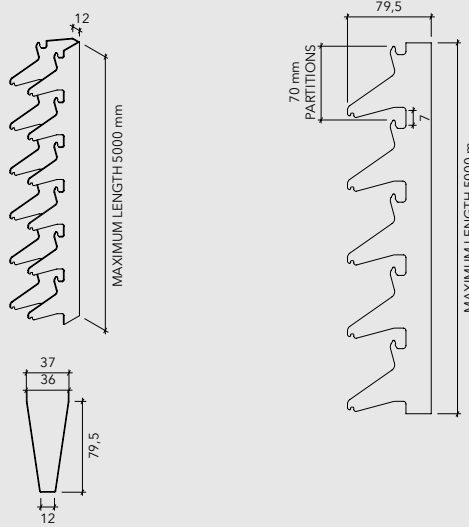

## TECHNICAL DESCRIPTION

PRODUCT	MATERIAL	THICKNESS (mm)	WEIGHT (kg/m <sup>2</sup> )		MAXIMUM LENGTH (mm)
			70 PARTITION	90 PARTITION	
70S LATTICE	ZINCALUME	0,5	7,50	6,17	6000
	ALUMINIUM	0,7	4,30	3,64	

Note: Calculated using lattice and carrier profile.

- Colors: Available in over 100 standard colors and in custom colors
- Finish: Smooth or perforated, wood or mineral grain
- Uses: Sunlouver
- Other materials available: Weathering steel, copper and zinc.
- Length: Varies by project requirement. We recommend that length not exceed 6 m

## ASSEMBLY

The panel carrier allows for quick and simple installation. The fasteners are hidden, which means that the final finishing is clean.



## INSTALLATION

### ISOMETRIC VIEW

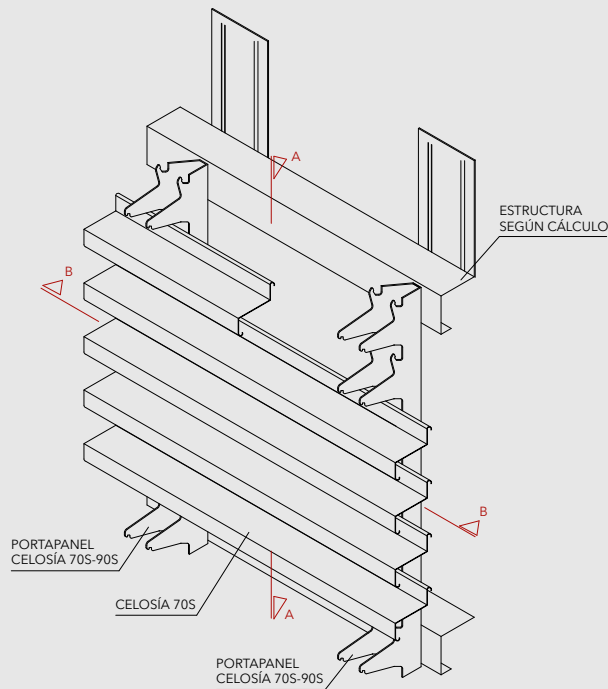

### CROSS SECTION A-A

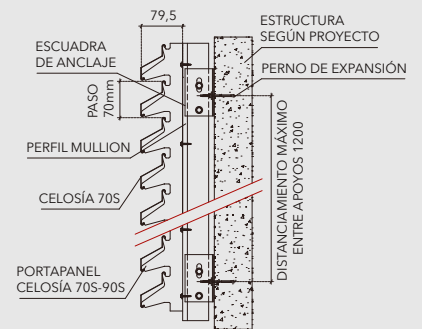

### METALLIC STRUCTURE INSTALLATION

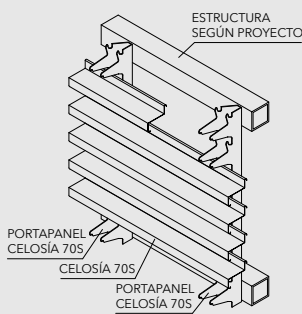

### WALL INSTALLATION

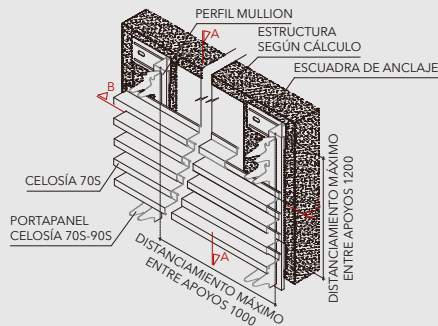

### CROSECTION B-B

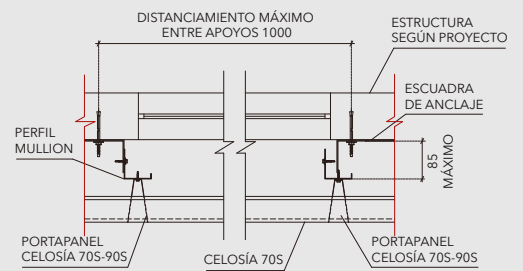

## STANDARD PERFORATION

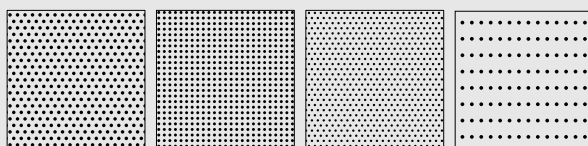

# 103	# 106	# 118	# 118 M2
Ø 3 mm	Ø 2,5 mm	Ø 2 mm	Ø 2 mm
20% open	16% open	15% open	7,3% open
6,35 mm	5,5 mm	8,6 mm	3 mm
5,5 mm	5,5 mm	5 mm	6,6 mm

Note: The components of this product are constantly being improved and developed, so modifications may be made. The measurements listed on this Technical Sheet are expressed in millimeters (mm). In order to ensure that the product works correctly, the installation should always be handled by an authorized distributor using all of the accessories listed and in accordance with Hunter Douglas technical specifications.

# H2-SL4 SUNSCREEN







# H2- SL4 SUNSCREEN

Solar Control | Linear sunlouvers

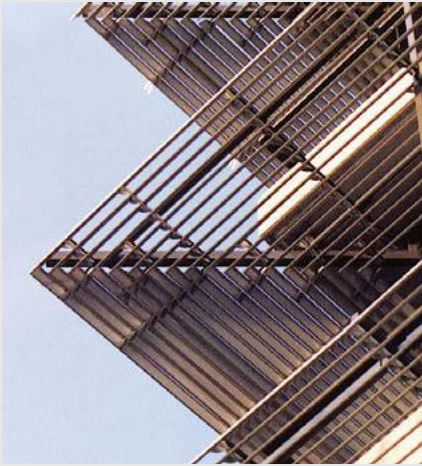

This is a fixed angle sunscreen system based on a modular 84R panel that is affixed to panel carrier profiles with sun impact angles of 76 and 45 degrees, creating two types of sunscreens, the H2 and the SL4, respectively. These sunlouvers are especially useful for sun protection of large industrial, commercial and residential spaces. They can be used as sun filters in front of windows or as an overhead sunscreen.

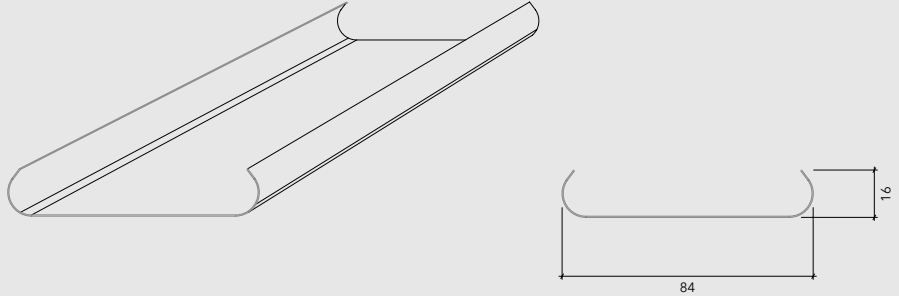

## TECHNICAL DESCRIPTION

PRODUCT	MATERIAL	THICKNESS (mm)	WEIGHT (kg/m <sup>2</sup> )	EFFICIENCY (panels/m <sup>2</sup> )	MAXIMUM LENGTH
H2 SUNSCREEN	ZINCALUME	0,4	6,3	14,5	6000
		0,5	7,5		
SL4 SUNSCREEN		0,4	5,6	11,8	
		0,5	6,6		

- Colors: Available in over 100 standard colors and in custom colors
- Finish: Smooth or perforated, wood or mineral grain
- Uses: Sunlouver
- Length: Varies by project requirement. We recommend that length not exceed 6 m
- Other materials available: Aluminum, copper and zinc



## ASSEMBLY

The panel carrier is affixed to the structure using self-drilling screws or a wood screw depending on the existing support structure. The 84R panel is then installed using pressure on the panel carrier.

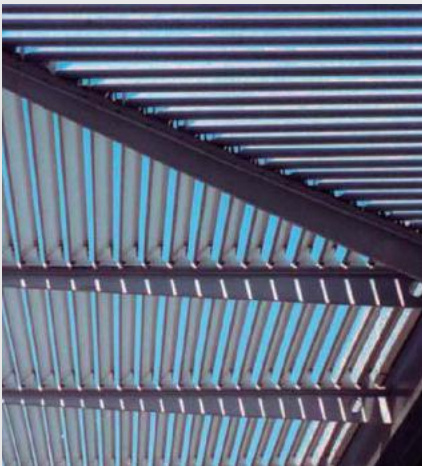

### CENTRAL SUNSCREEN

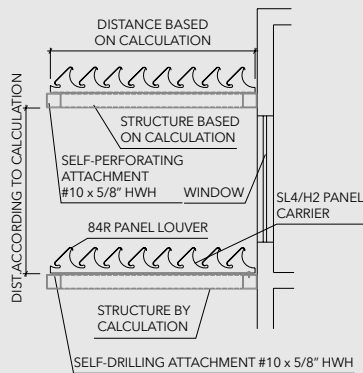

### VARIABLE BY PROJECT

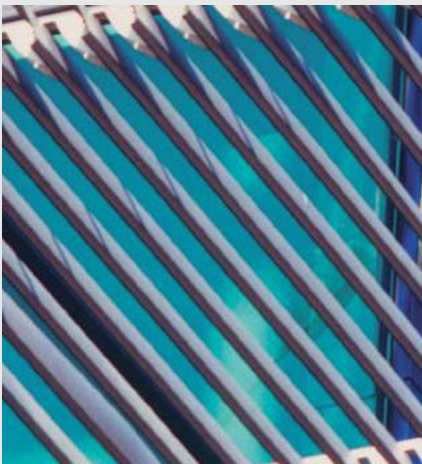
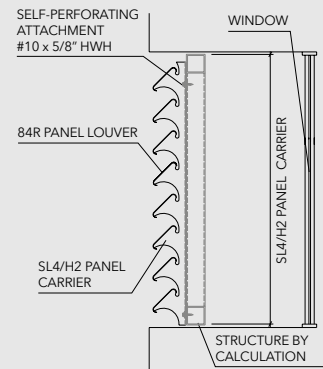

### INSIDE OF BAY

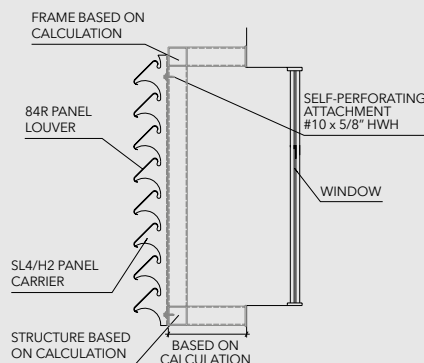

## INSTALLATION

### ISOMETRIC SL4/H2 LOUVER CARRIER AND SUBSTRUCTURE

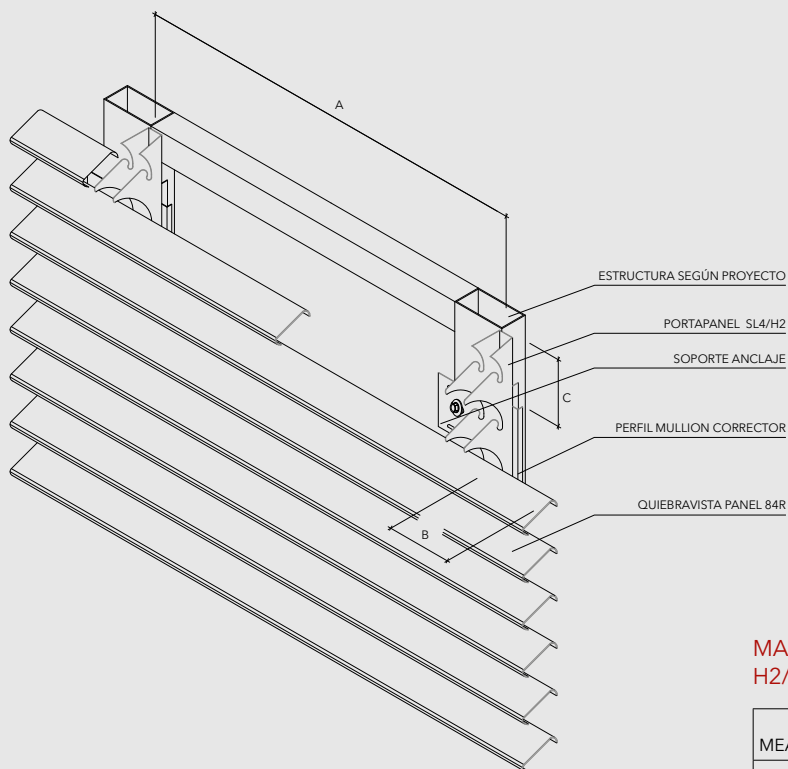

MAX. DISTANCING  
H2/SL4 PANEL CARRIER

MAX. MEASUREMENTS	A	B	C
SL4 / H2	1200	100	100

### ASSEMBLY OPTIONS

#### SL4 CARRIER

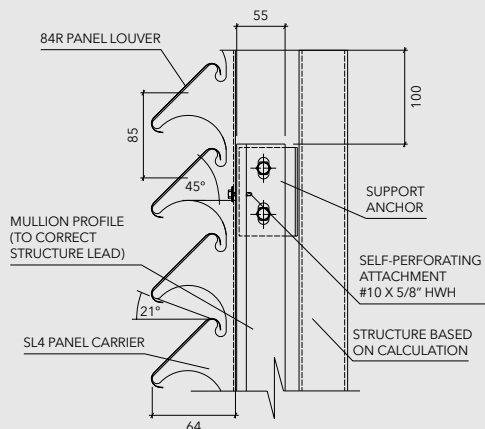

#### H2 CARRIER

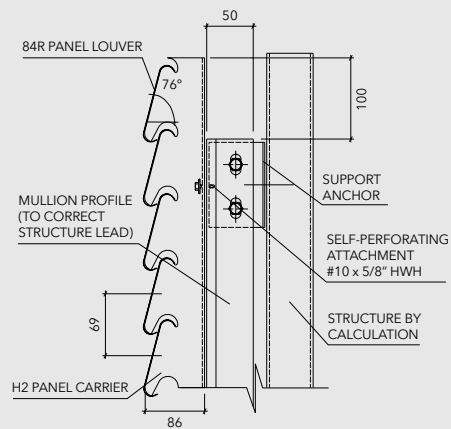

### STANDARD PERFORATIONS

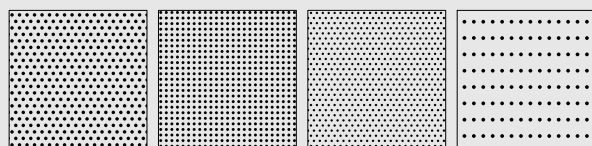

# 103	# 106	# 118	# 118 M2
Ø 3 mm	Ø 2,5 mm	Ø 2 mm	Ø 2 mm
20% open	16% open	15% open	7,3% open
↔ 6,35 mm ↑ 5,5 mm	↔ 5,5 mm ↑ 5,5 mm	↔ 8,6 mm ↑ 5 mm	↔ 3 mm ↑ 6,6 mm

Note: The components of this product are constantly being improved and developed, so modifications may be made. The measurements listed on this Technical Sheet are expressed in millimeters (mm). In order to ensure that the product works correctly, the installation should always be handled by an authorized distributor using all of the accessories listed and in accordance with Hunter Douglas technical specifications.

# FLAT SUNLOUVERS





# FLAT SUNLOUVERS

Solar Control | Linear sunlouvers



The Flat 25-50 sunscreen is a metallic product appropriate for use on horizontal or vertical façades. It is composed of rectangular panels. Due to its composition, which includes aluminum honeycomb in its interior, it provides unbeatable flatness for its external surfaces and impressive structural rigidity, allowing for support distances only on the ends.

The finish options are very varied and include solid colors as well as imitation wood paints and other materials such as weathering steel, zinc, copper and aluminum with special finishes.

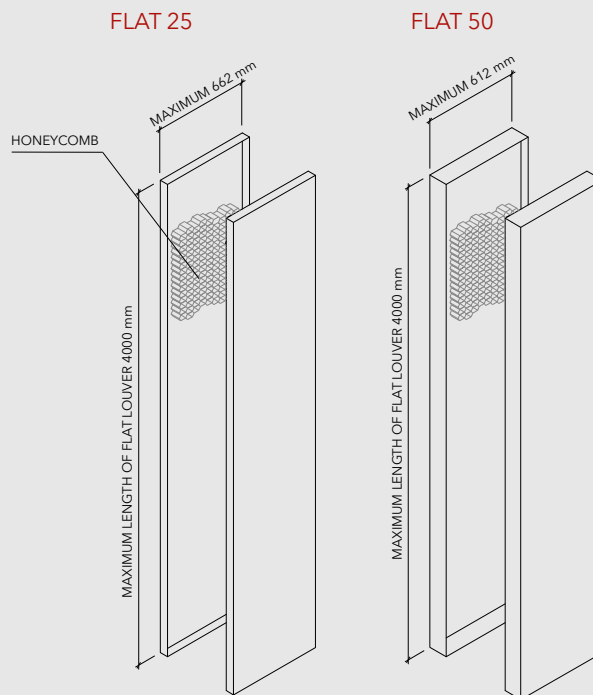

## TECHNICAL DESCRIPTION

PRODUCT	MATERIAL	TYPE	THICKNESS (mm)	WEIGHT kg/m <sup>2</sup>
FLAT 25	ALUMINUM	TRAY	1,2	4,1
		COVER	0,7	2,4
	ZINCALUME	TRAY	0,8	7,9
		COVER	1,0	9,8
		COVER	0,6	5,9

PRODUCT	MATERIAL	TYPE	THICKNESS (mm)	WEIGHT kg/m <sup>2</sup>
FLAT 50	ALUMINUM	TRAY	1,2	4,9
		COVER	0,7	2,8
	ZINCALUME	TRAY	0,8	9,4
			1,0	11,8
		COVER	0,6	7,1

- Material: Zincalume, aluminum
- Thickness: Aluminum between 0.7 and 1.2 mm, zincalume between 0.8 and 1 mm (depending on modulations and details of the project/product)
- Colors: Available in over 100 standard colors and in custom colors, wood grains and mineral grains
- Termination: Smooth
- Uses: Sunlouver
- Maximum length: 4000 m
- Yield: Varies depending on the project design
- Maximum module: 557 mm (Flat 25 mm), 507 mm (Flat 50 mm)
- Special materials: Weathering steel, aluminum, copper, zinc

- Notes:
1. Final geometry must be validated based on the studies of the load
  2. All of the measurements are expressed in millimeters
  3. Consult with the specification area for special measurements
  4. Product requires detail engineering in all projects

## INSTALLATION

### FLAT 25 SUNLOUVER (OUTSIDE MOUNT)

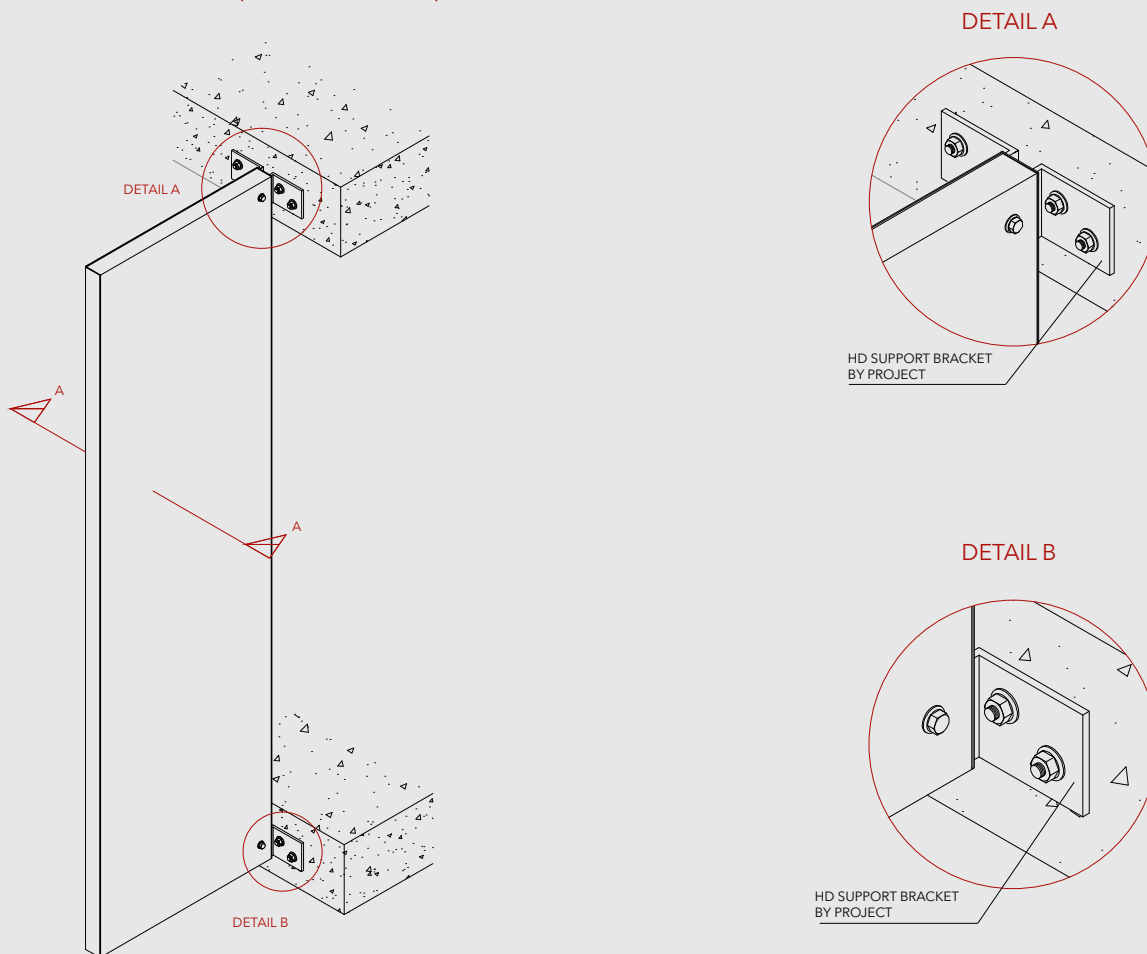

### CROSS SECTION A-A

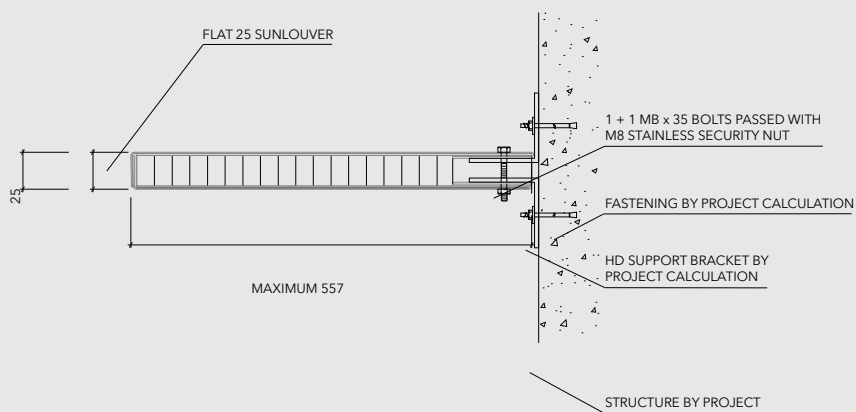

# FLAT SUNLOUVERS

Solar Control | Linear sunlouvers



FLAT 25 LOUVER INSTALLATION INSIDE OPENING

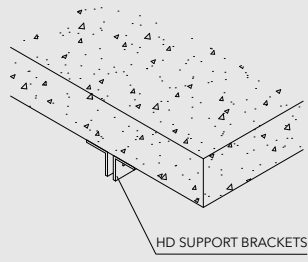

HD SUPPORT BRACKETS

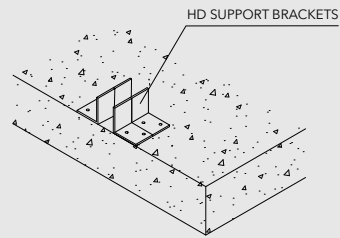

HD SUPPORT BRACKETS

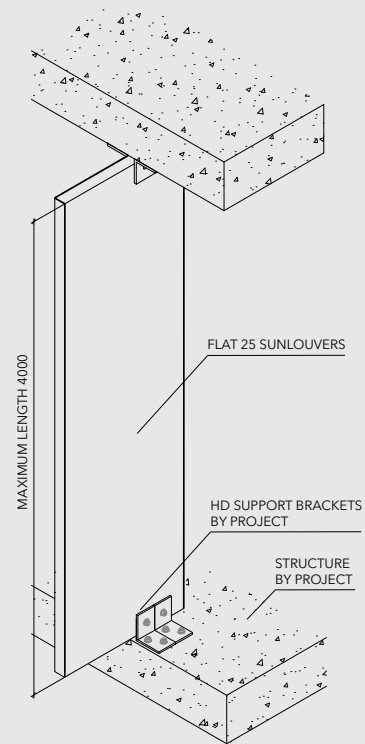

MAXIMUM LENGTH 4000

FLAT 25 SUNLOUVERS

HD SUPPORT BRACKETS BY PROJECT

STRUCTURE BY PROJECT



CUT A-A

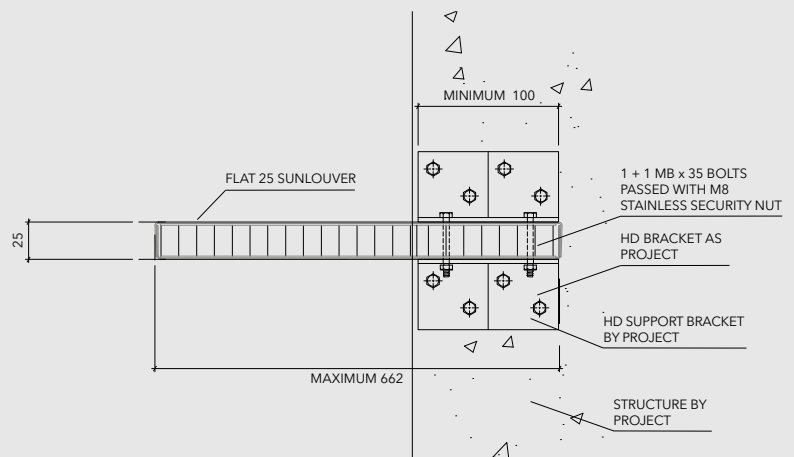



## INSTALLATION

### FLAT 50 LOUVER OUTSIDE OPENING

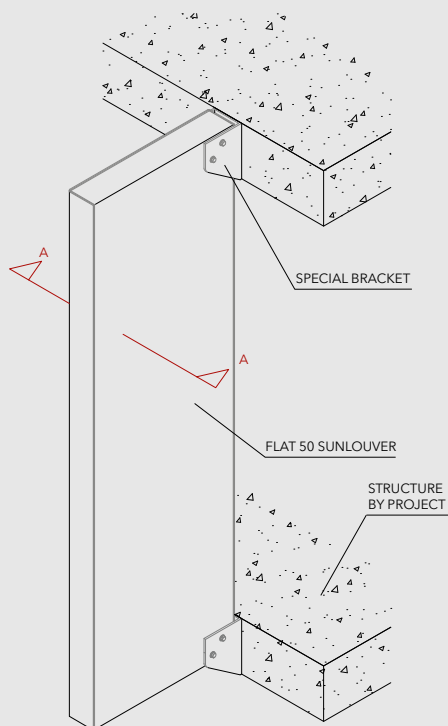

#### CUT A-A

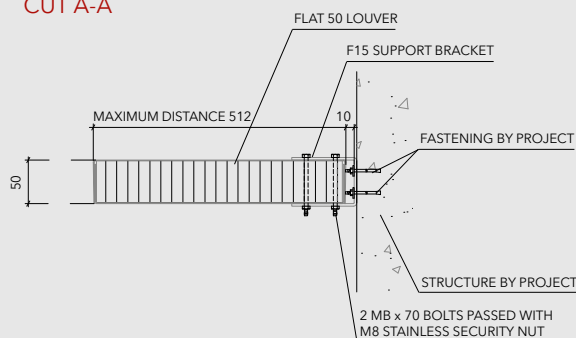

### FLAT 50 LOUVER INSIDE OF BAY

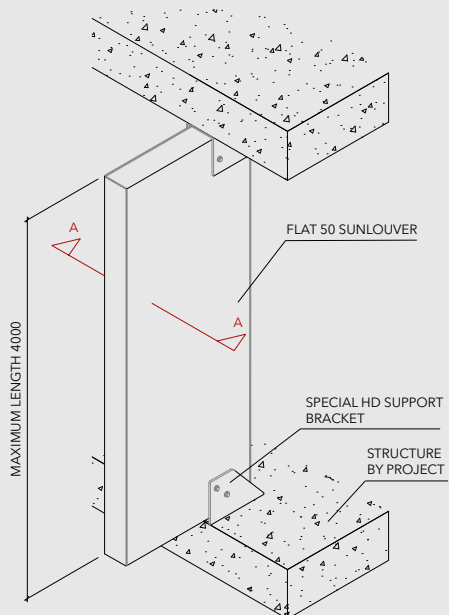

#### CUT A-A

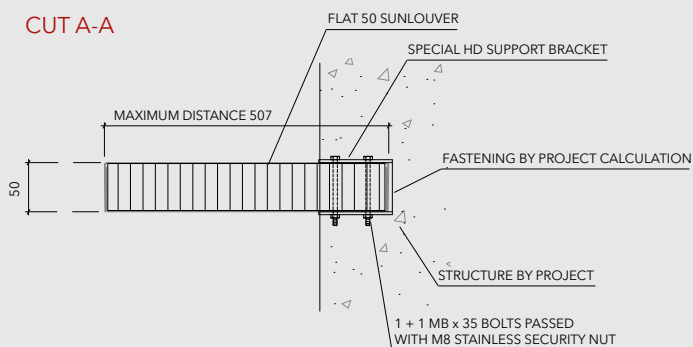

Note: The components of this product are constantly being improved and developed, so modifications may be made. The measurements listed on this Technical Sheet are expressed in millimeters (mm). In order to ensure that the product works correctly, the installation should always be handled by an authorized distributor using all of the accessories listed and in accordance with Hunter Douglas technical specifications.

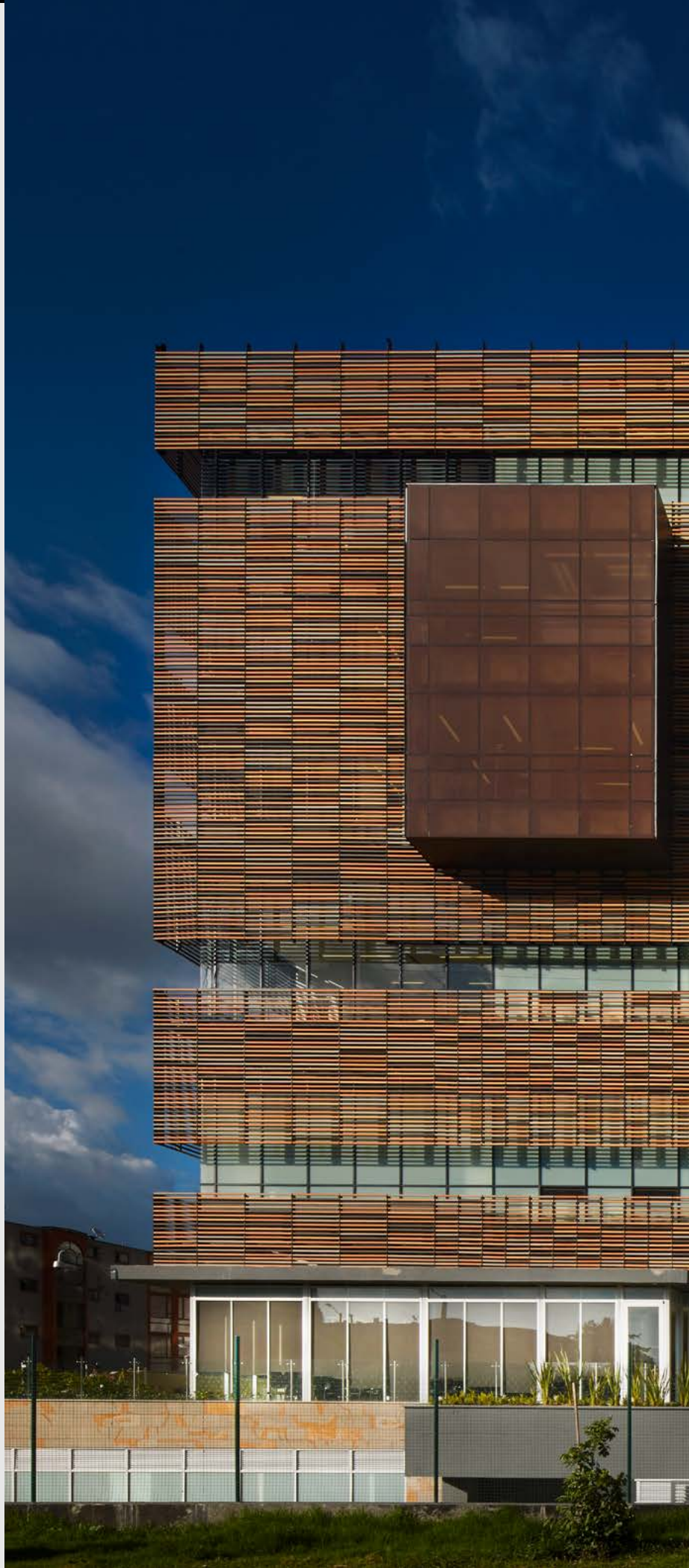





NBK has been a pioneer in the manufacture and design of large format ventilated terracotta ceramic façades. The clay used to make the ceramic panels is a natural material that provides quality and durability and has been used for centuries on buildings around the world.

It is a cutting-edge contribution to architecture due to its flexibility, rich range of colors and inherent sustainability.

The Baguette is a hollow ceramic element with a square or rectangular section. This versatile product is mainly used in windows or for the design of ventilated façades. In the area of sun protection, Baguette offers ideal protection in combination with Terrart Light lining.

This product is easy to install using lateral supports or rear fasteners.

## TECHNICAL DESCRIPTION

- Material: Ceramic terracotta lining
- Crosssection ø: 50, 60, 70 mm
- Colors: Available in over 20 standard colors as well as custom colors
- Uses: Lining, louver
- Maximum length: 1,8 m

PRODUCT	MATERIAL	PIECE WEIGHT (kg/ml)	THICKNESS (mm)	MAXIMUM LENGTH (mm)
BAGUETTE 50 x 50 cm	TERRACOTA	3,75	11	1800

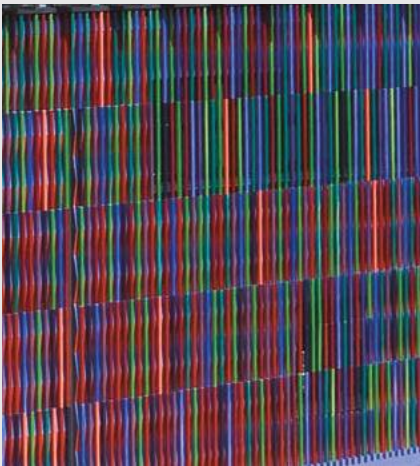

## AVAILABLE FORMATS SQUARE SECTIONS

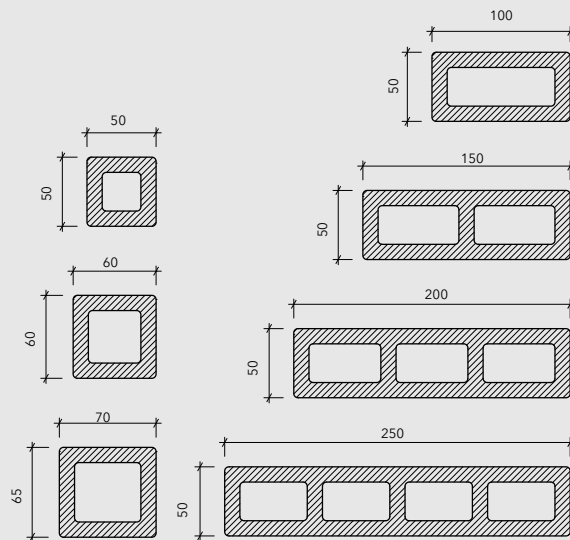

## ISOMETRIC BAGUETTE

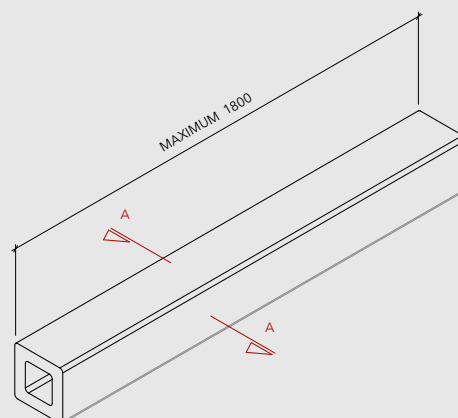

## CROSSSECTION A-A

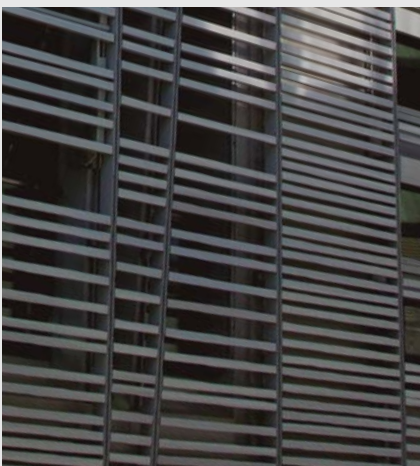
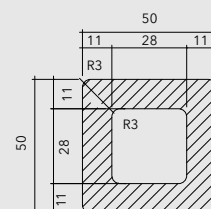



**NBK**

Solar Control | Linear baguettes





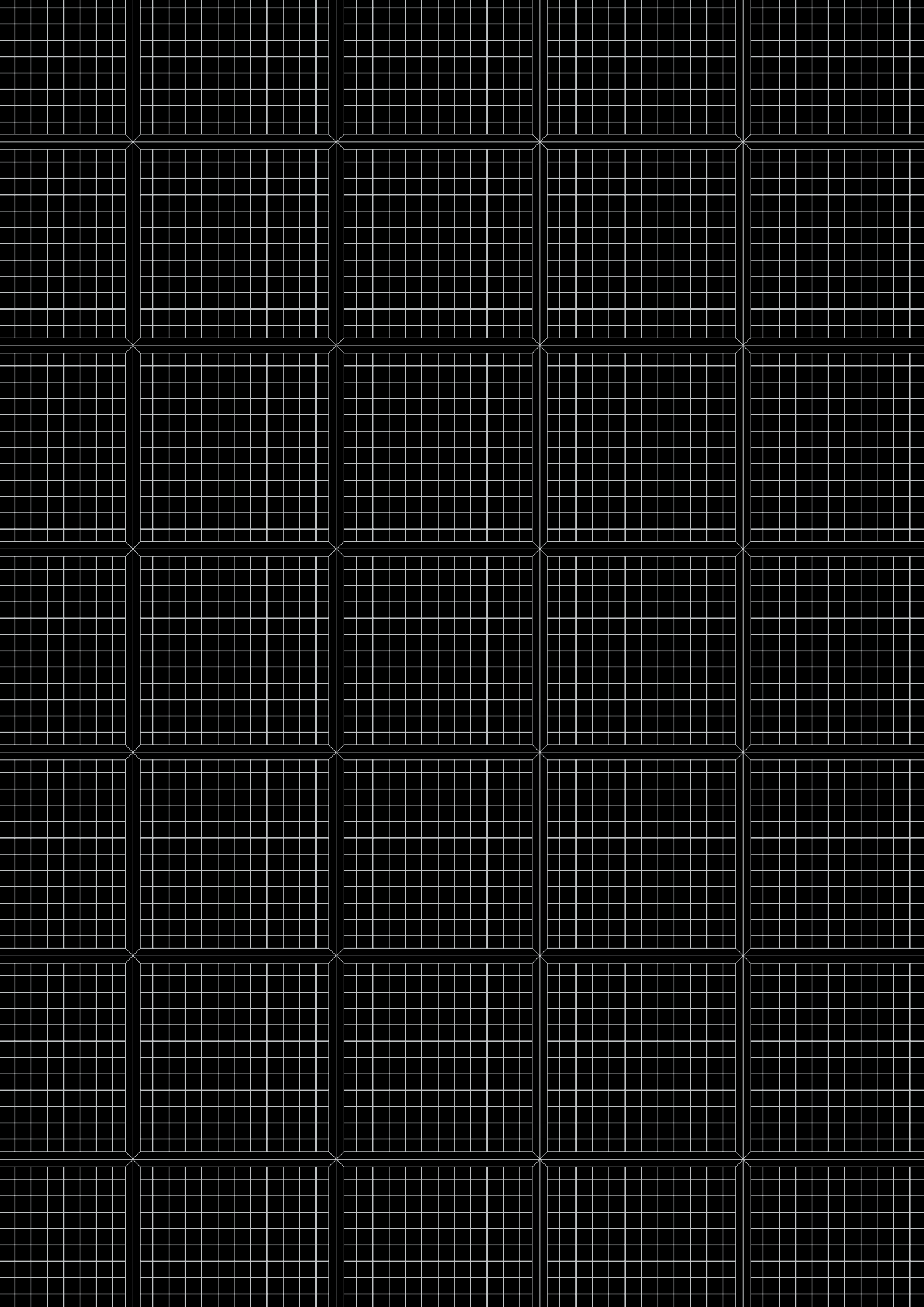



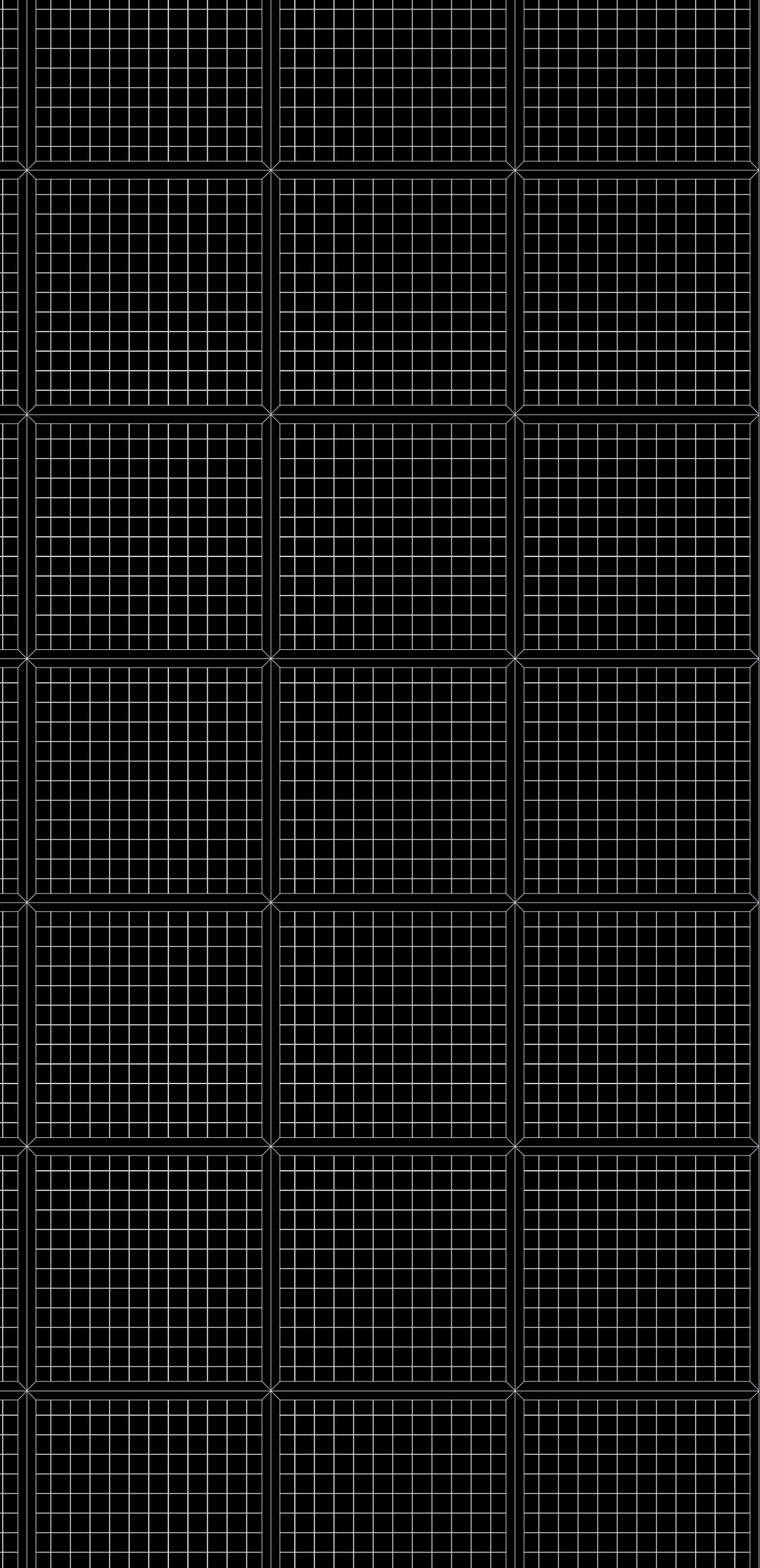

**MESH SUNSCREENS**

# BRISOLCELL

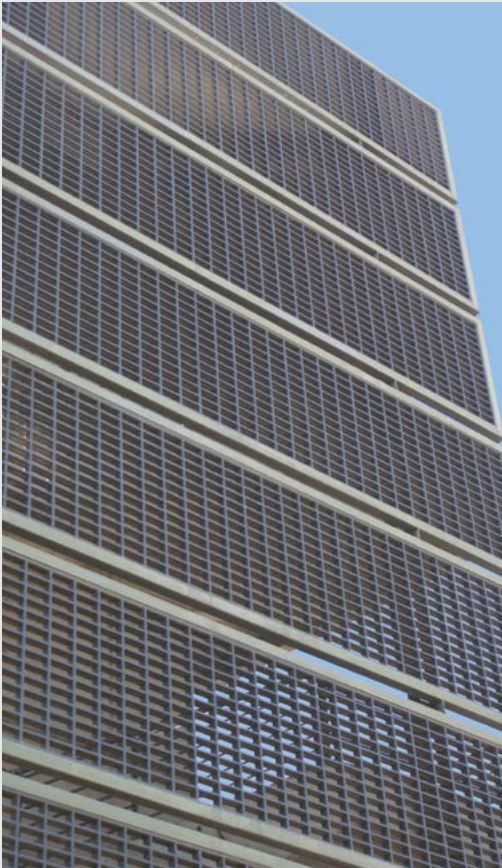



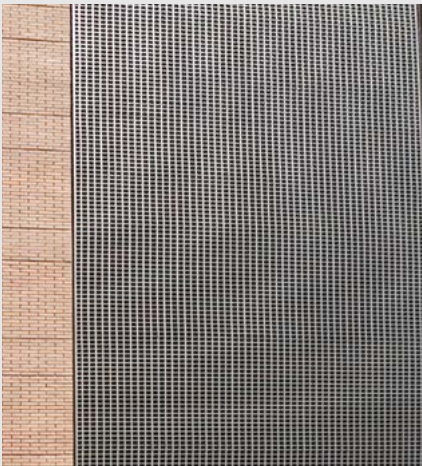

BrisolCell is a panel composed of right and left profiles forming square or rectangular modules with variable spacing that are connected to another panel using polycarbonate fasteners in order to obtain a compact element with a high level of workmanship on both the outside and inside. This panel is useful for façades when large lights need to be covered, such as in staircase areas, loggias or ceilings in eaves.

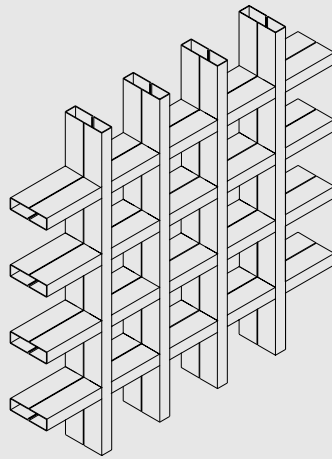

## RIGHT PROFILE

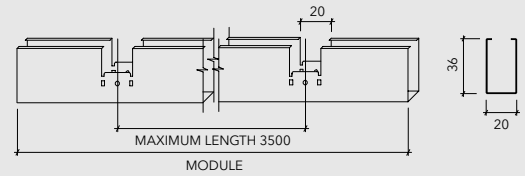

## LEFT PROFILE

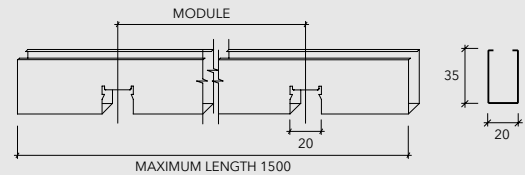

## TECHNICAL DESCRIPTION

PRODUCT	MODULE (mm)	MATERIAL	THICKNESS (mm)	WEIGHT (kg/m <sup>2</sup> )	EFFICIENCY (ml/m <sup>2</sup> )
BRISOLCELL	100	ZINCALUME	0,4	12,28	40
			0,5	15,36	
	150		0,4	8,18	28
			0,5	10,22	
	200		0,4	6,14	20
			0,5	7,68	
	250		0,4	4,91	16
			0,5	6,14	
300	0,4	4,05	12		
	0,5	5,06			

- Colors: Available in over 100 standard colors and in custom colors, wood grains or mineral grains
- Finish: Smooth
- Uses: Sunscreen
- Length: Varies by project requirement
- Other materials available: Weathering steel, aluminum, copper and zinc

We recommend not exceeding 50 kg per assembled grid in order to facilitate installation.

Feasibility of special modules should be coordinated with our technical department.

## ASSEMBLY

BrisolCell is installed using galvanized steel anchor with finishing paint. This is fastened directly to the structure using a bracket that is also made of galvanized steel that is connected to the BrisolCell. The anchor is installed on four points per panel. The mounting will depend on the type of structure (expansion or self-perforating bolt).

## INSTALLATION

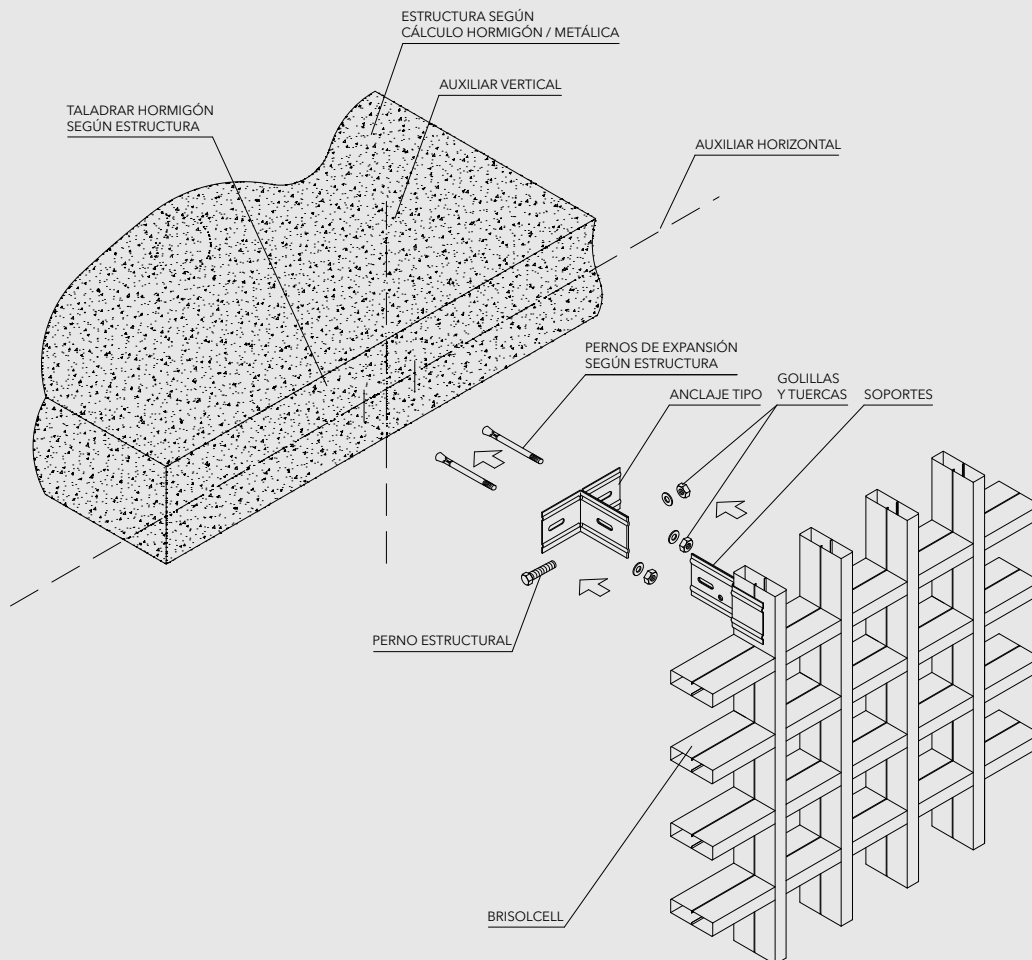

### BRACKET

### CROSS SECTION VIEW

### UPPER/LOWER FINISH INSIDE OF BAY

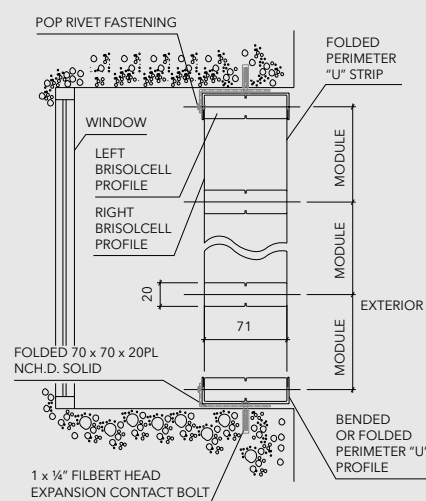
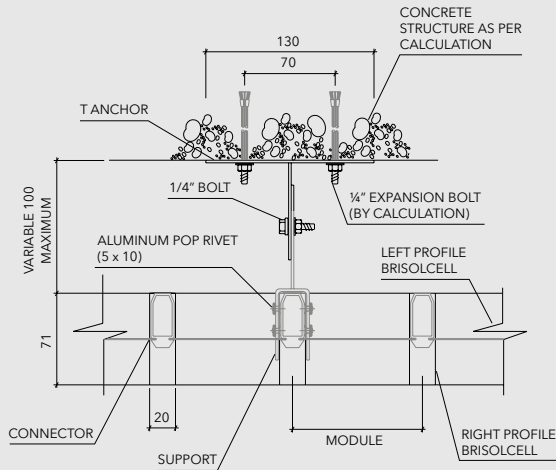
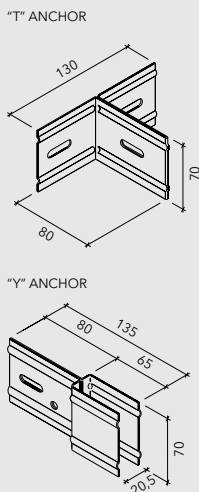

Note: The components of this product are constantly being improved and developed, so modifications may be made. The measurements listed on this Technical Sheet are expressed in millimeters (mm). In order to ensure that the product works correctly, the installation should always be handled by an authorized distributor using all of the accessories listed and in accordance with Hunter Douglas technical specifications.







Filigree is an attractive sun control solution. It has been especially designed as an overhead sunshade. It is a panel composed of metallic sheets that form a grid with variable modules framed by extruded aluminum profiles. It is available in various formats which can be used vertically or horizontally. The maximum surface area of each module is 3 m<sup>2</sup>.

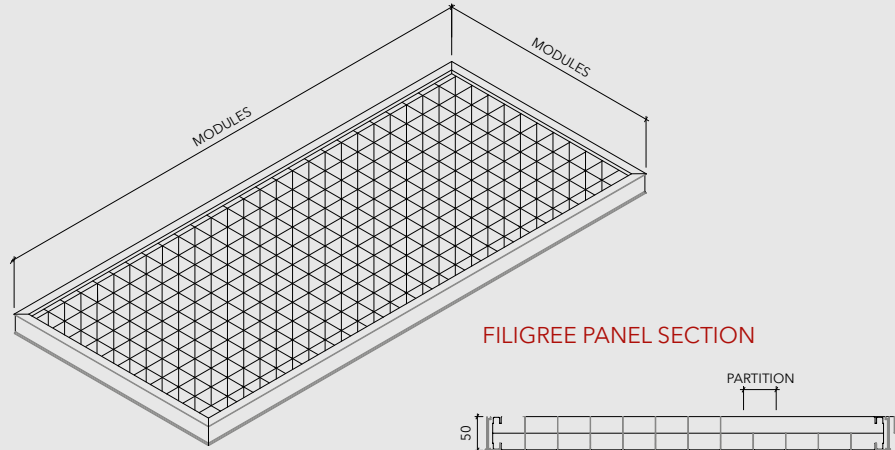

## TECHNICAL DESCRIPTION

PARTITION	MODULE (mm)	THICKNESS (mm)	WEIGHT (kg/m <sup>2</sup> )	YIELD (panels/m <sup>2</sup> )	PARTITION	MODULE (mm)	THICKNESS (mm)	WEIGHT (kg/m <sup>2</sup> )	YIELD (panels/m <sup>2</sup> )
49 x 49	610 x 610	0,4	10,5	2,7	49 x 98	610 x 610	0,4	8,5	2,7
	610 x 1198			1,4		610 x 1198			1,4
	610 x 1786			0,9		610 x 1786			0,9
	1198 x 2373			0,4		1198 x 2373			0,4
	610 x 610	0,5	12,4	2,7		610 x 610	0,5	10	2,7
	610 x 1198			1,4		610 x 1198			1,4
	610 x 1786			0,9		610 x 1786			0,9
	1198 x 2373			0,4		1198 x 2373			0,4
	610 x 610	0,6	14,3	2,7		610 x 610	0,6	11,4	2,7
	610 x 1198			1,4		610 x 1198			1,4
	610 x 1786			0,9		610 x 1786			0,9
	1198 x 2373			0,4		1198 x 2373			0,4

- Colors: Available in over 100 standard colors as well as custom options
- Finish: Smooth
- Uses: Sunscreens, cenital sunlouvers,
- Other materials available: Weathering steel, aluminum, copper and zinc

## ASSEMBLY

The installation of this product depends on the project. The modules are fixed directly to the structure using the aluminum frame.

### INSTALLATION SYSTEM UPPER AND LOWER DETAIL

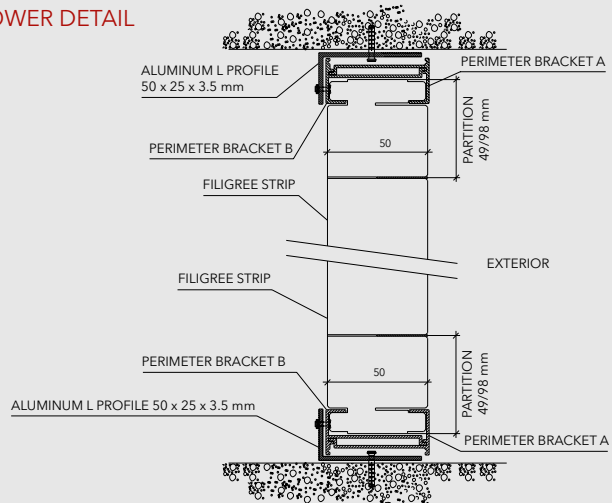



# INSTALLATION

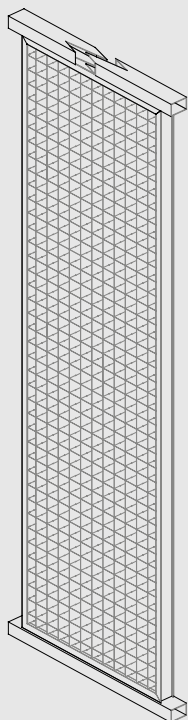

## COMPONENTS

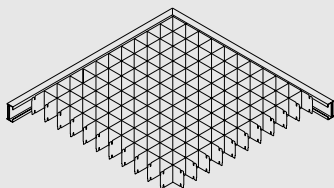

## PERIMETER BRACKET CONNECTION SYSTEM

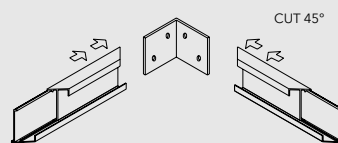

Note: Frame and components vary by size.

## FILIGREE STRIP

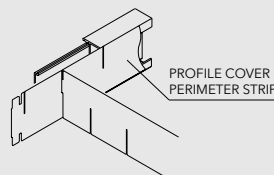
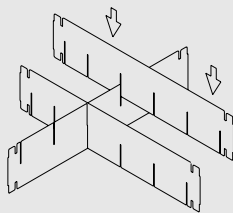

## UPPER DETAIL

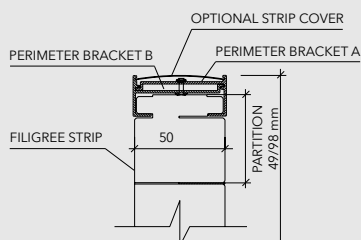

## INSTALLATION DETAIL

### UPPER DETAIL

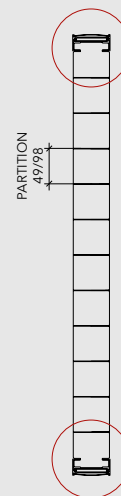

## LOWER DETAIL

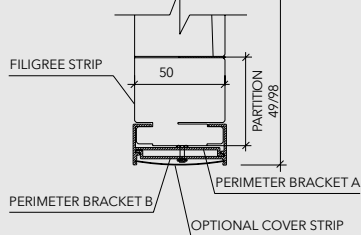

### LOWER DETAIL

## MODULE AND PARTITION FORMAT

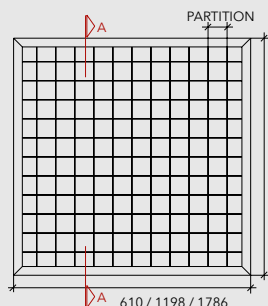

## CUT A-A

49 mm. x 49 mm

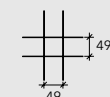

49 mm x 98 mm



98 mm x 49 mm

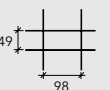

## FOLDING SHUTTER DETAIL

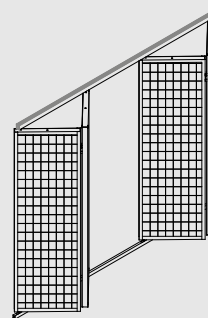

## SLIDING SHUTTER DETAIL

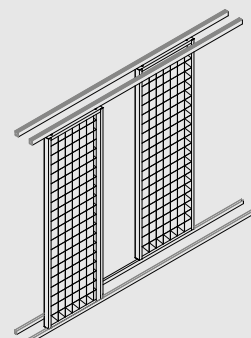

## ELEVATION

Note: The components of this product are constantly being improved and developed, so modifications may be made. The measurements listed on this Technical Sheet are expressed in millimeters (mm). In order to ensure that the product works correctly, the installation should always be handled by an authorized distributor using all of the accessories listed and in accordance with Hunter Douglas technical specifications.

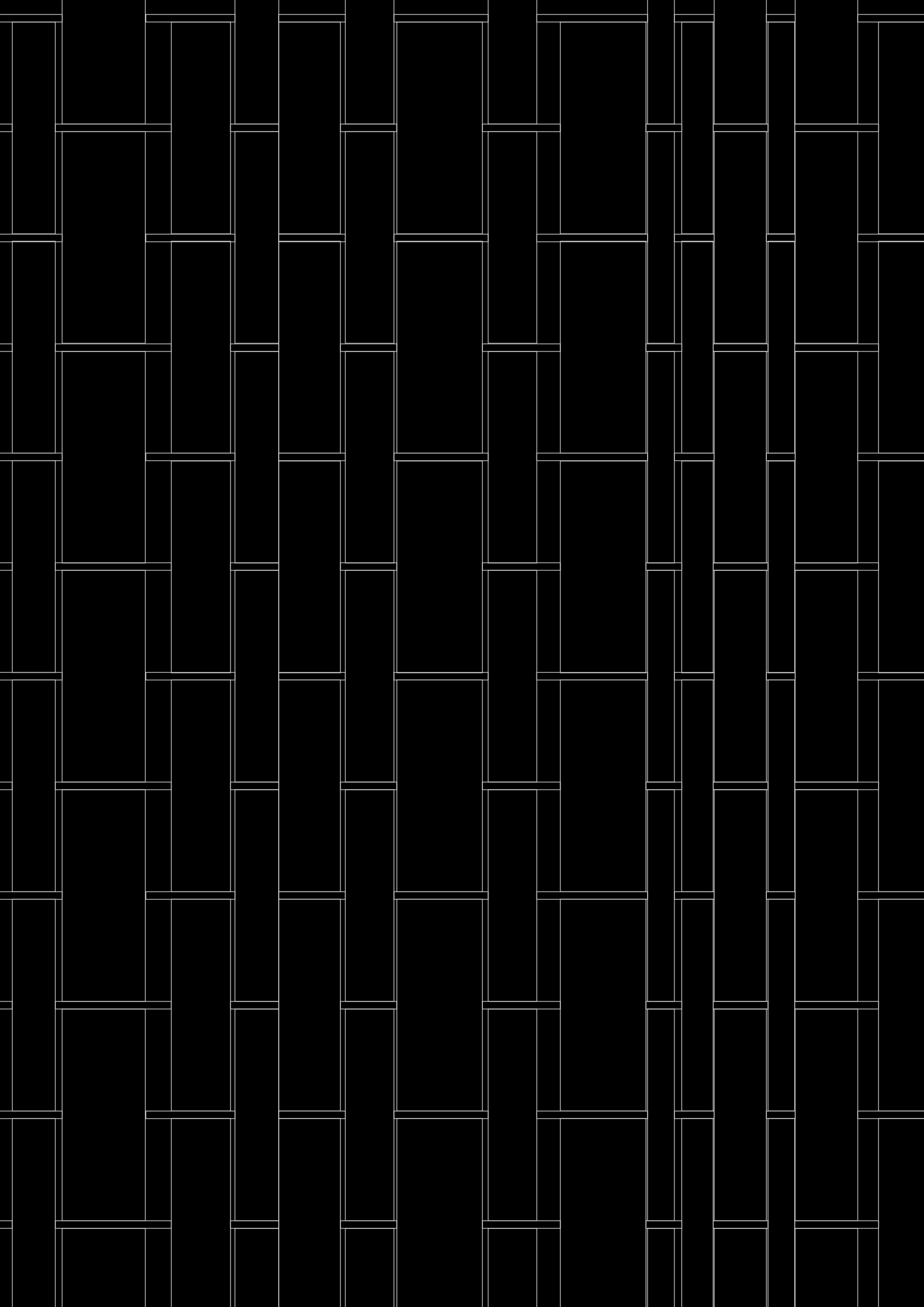

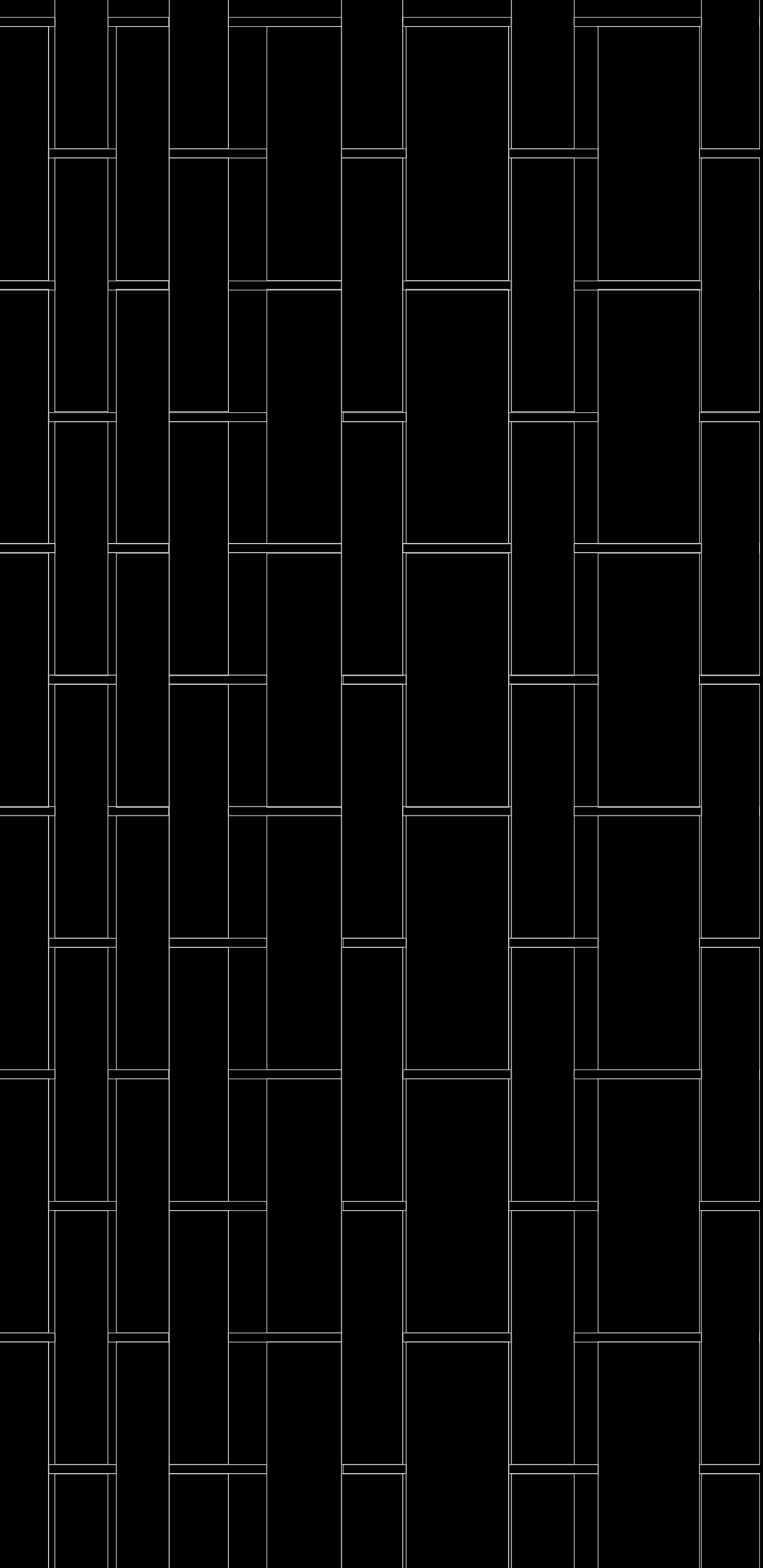

**SCREEN PANELS**

# STRIPWEAVE





# STRIPWEAVE

Solar Control | Screen strips

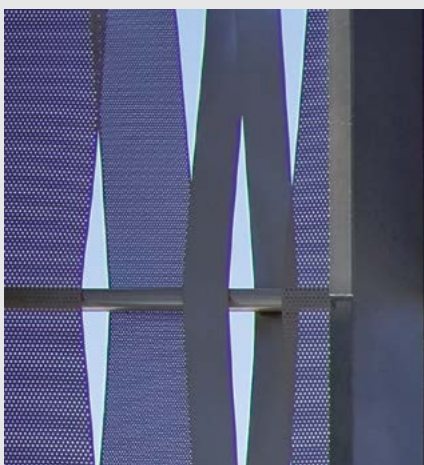
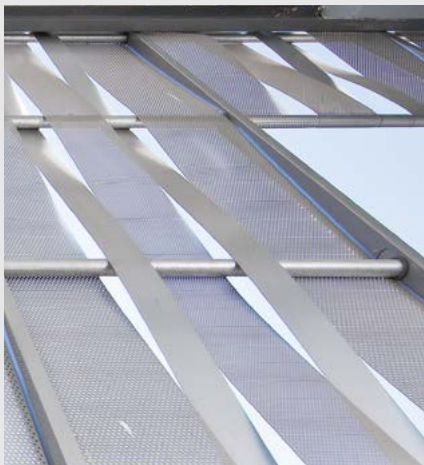

Stripweave is a simple product, but it allows for very interesting results. It has metallic ribbons or strips that weave between tubular profiles unique to this system. The outcome is very similar to a weaving, but on a large scale. It also allows for the creation of transparencies and opacities.

## SIMPLE TUBE STRIPWEAVE

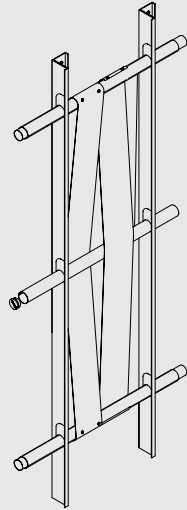

## DOUBLE TUBE STRIPWEAVE

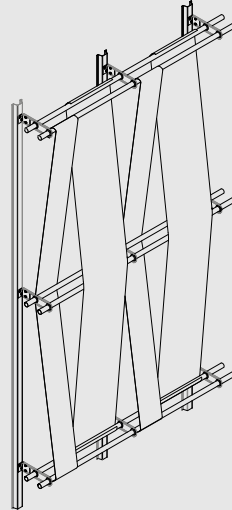

## TECHNICAL DESCRIPTION

PRODUCT	MATERIAL	STRIP WIDTH (mm)	THICKNESS (mm)	WEIGHT (kg/m <sup>2</sup> )
SIMPLE STRIPWEAVE COVERING	ZINC-ALUMINUM	100	0,5	4,0
		150	0,5	4,2
		200	0,5	4,5
		300	0,5	4,8

Note: Estimated weight- will depend on the width and perforation type of the strips.

- Colors: Available in over 100 standard colors as well as custom options, wood grains or mineral grains
- Finish: Smooth or perforated
- Uses: Façade cladding and sunsreen
- Length: Variable
- Other materials available: Weathering steel, aluminum, copper and zinc

## ASSEMBLY

Stripweave is assembled using horizontal and vertical elements fixed at a preset distance. The vertical strip is then woven through them.

## COMPONENTS

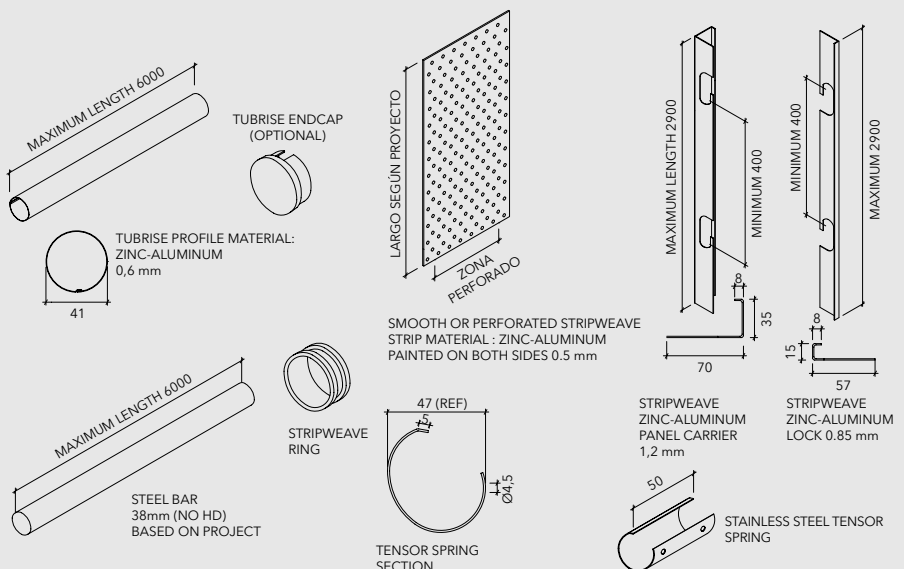

## INSTALLATION

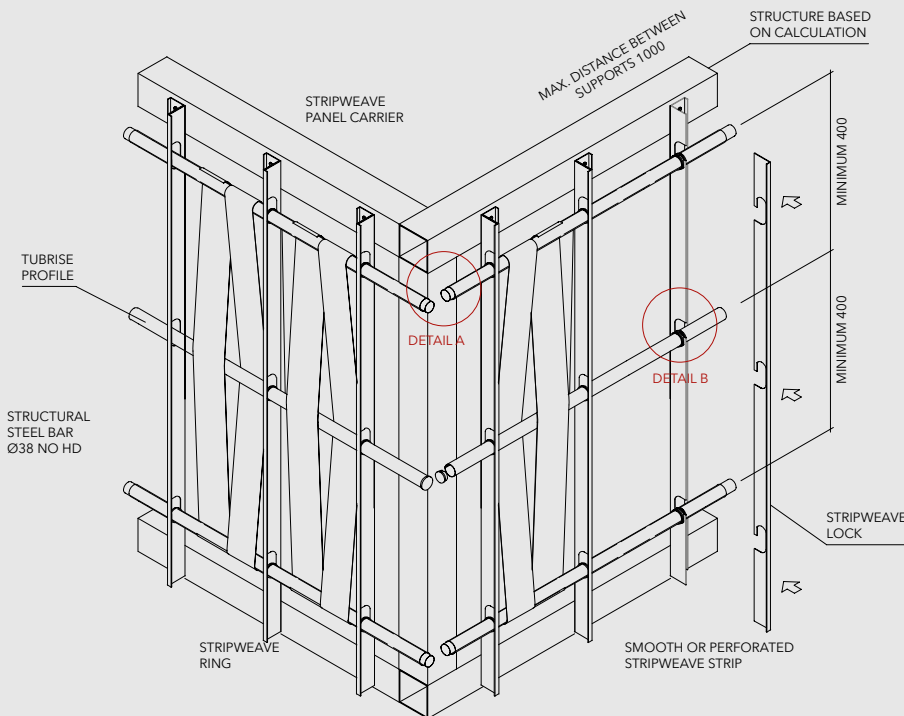

DETAIL A

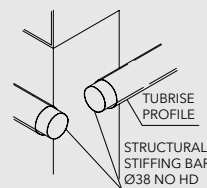

Note: Use a structural ø38 steel bar on the inside of the Tubrise profile in the beginning and end of the weave to support the tension of the strip. This solution is used if the project requires it.

DETAIL B

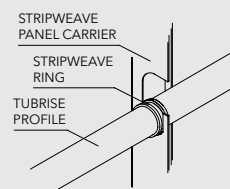

ISOMETRIC VIEW: STRIPWEAVE PROFILE CONNECTOR

STRIPWEAVE TENSOR SPRING INSTALLATION SYSTEM

STRIPWEAVE INSTALLATION SYSTEM - OPTION WITH SPRING

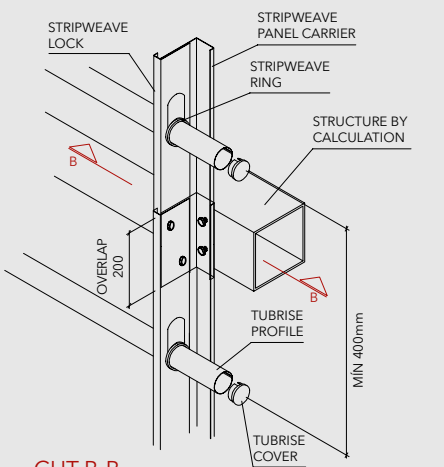

CUT B-B

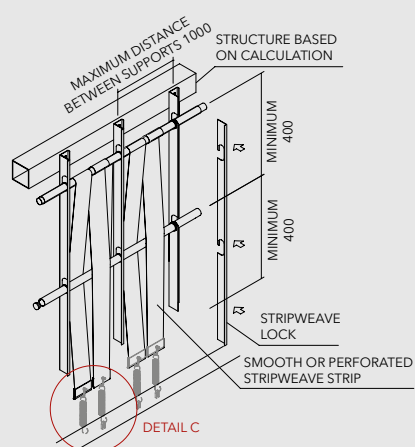
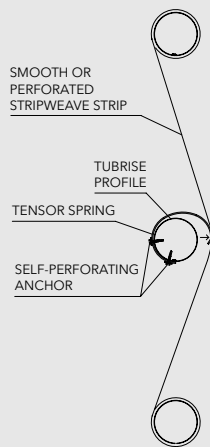

DETAIL C

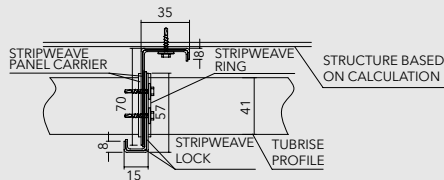
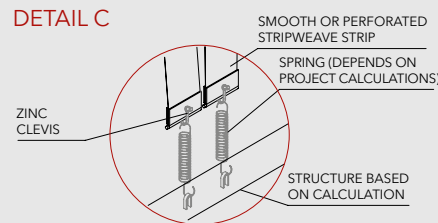

## STANDARD PERFORATIONS

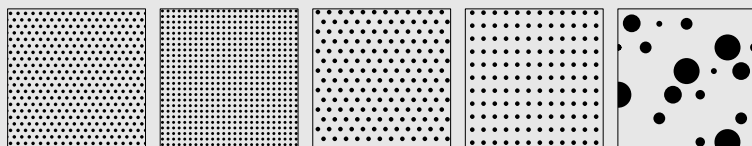

# 103	# 106	# 110-M1	# 110-M3	# 420
Ø 3 mm	Ø 2,5 mm	Ø 3,9 mm	Ø 3,9 mm	Ø 5 / 8 / 10 / 15 / 22 mm
20% open	16% open	21% open	21% open	18% open
6,35 mm	5,5 mm	9,53 mm	9,53 mm	5,5 mm
5,5 mm	5,5 mm	8,25 mm	11 mm	10 mm

Note: The components of this product are constantly being improved and developed, so modifications may be made. The measurements listed on this Technical Sheet are expressed in millimeters (mm). In order to ensure that the product works correctly, the installation should always be handled by an authorized distributor using all of the accessories listed and in accordance with Hunter Douglas technical specifications.

# STRIPWEAVE

Solar Control | Screen strips







# STRIPSCREEN

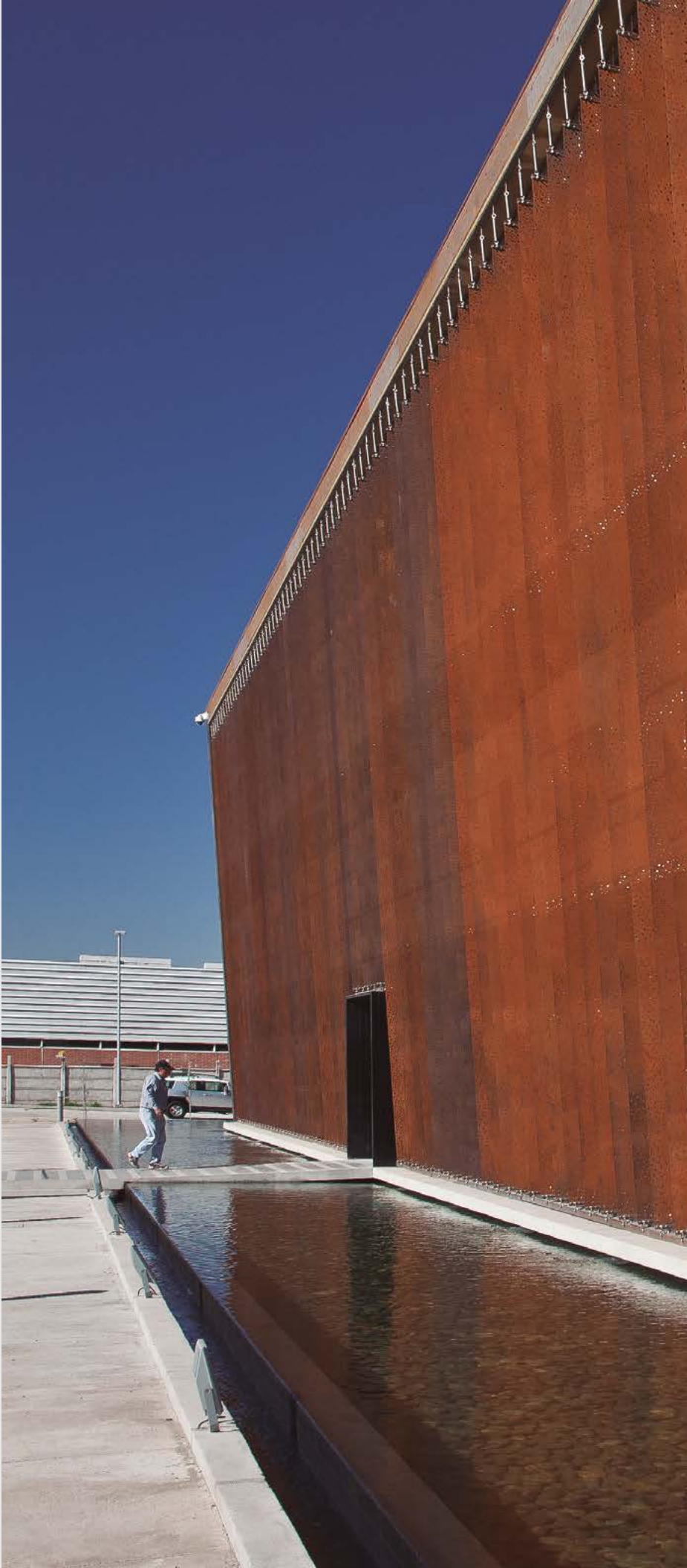



# STRIPSCREEN

Solar Control | Screen strips

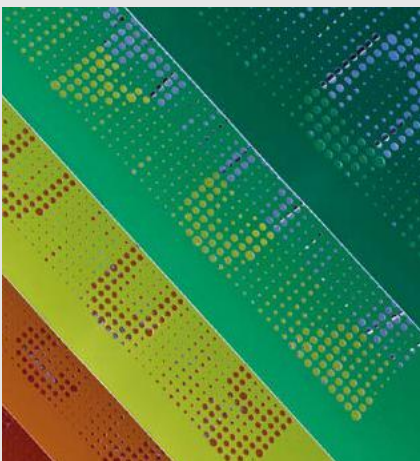

Stripscreen is an innovative product that gives façades an unique and renewed appearance. The product uses a vertical strip supported solely on two parts of the façade and provides an image of lightness as well as energy efficiency. It is a versatile product because in addition to being able to vary the spacing between the fixed elements, one can combine different widths of strips, colors and perforations. The perforated alternative allows for translucent or backlit façades and for the facing to be used as a passive sun control element.

## TECHNICAL DESCRIPTION

- Material: Zinalume, galvanized steel
- Thickness: 1,0 mm, 0,8 mm or 0,6 mm
- Colors: Available in over 100 standard colors as well as custom options
- Finish: Smooth or perforated
- Uses: Sunlouver
- Lengths: Maximum length 10 m
- Modules: Minimum 250 mm and maximum 605 mm
- Other available materials: Weathering steel, aluminium

Note: Due to the length and wind load requests, this product always requires engineering calculations to determine the type of accessories (spring, tensor and supporting structure to be used). The number and type of accessories may vary depending on the work conditions.

### ISOMETRIC PERFORATED PANEL

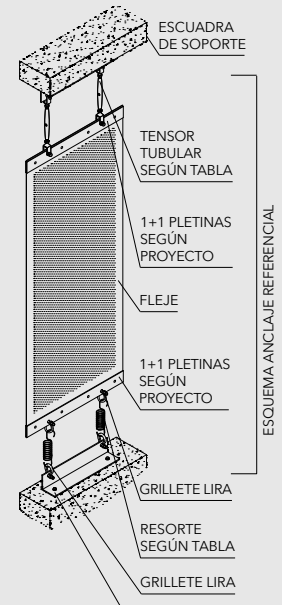

## ASSEMBLY

### REFERENCE ANCHOR FRAMEWORK

The number and type of accessories may vary depending on the work conditions.

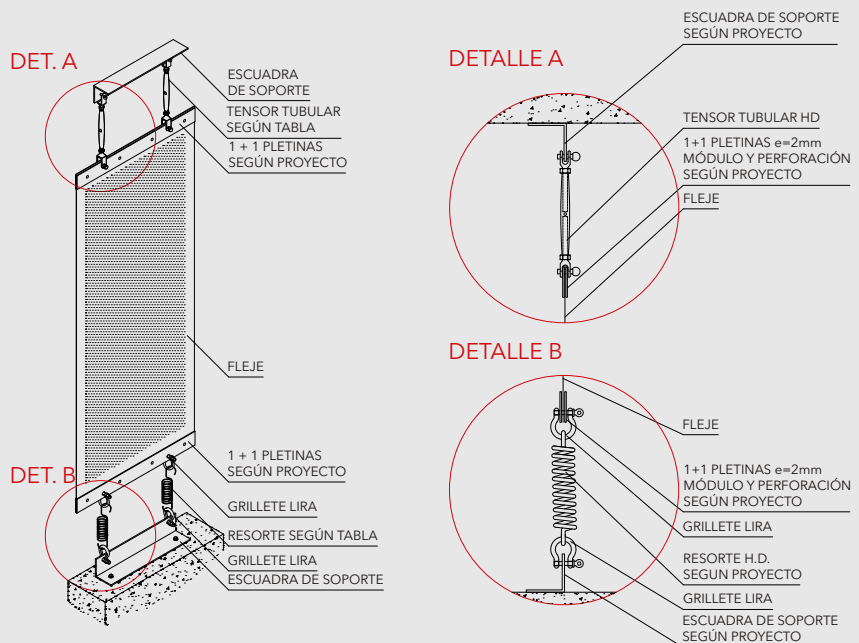

## PERFORATIONS

### PERFORATION PATTERN BASED ON IMAGES

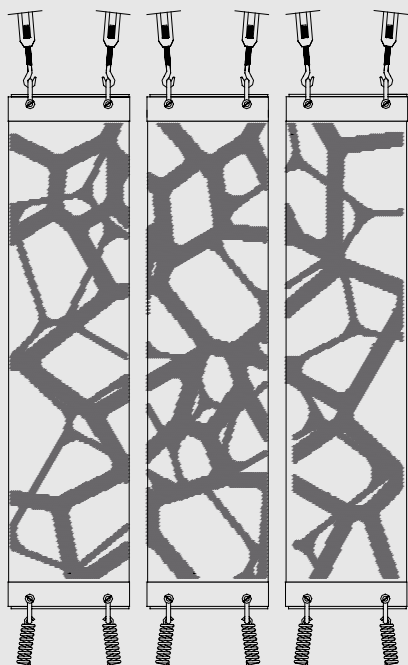

### 420 RANDOM PERFORATION PATTERN

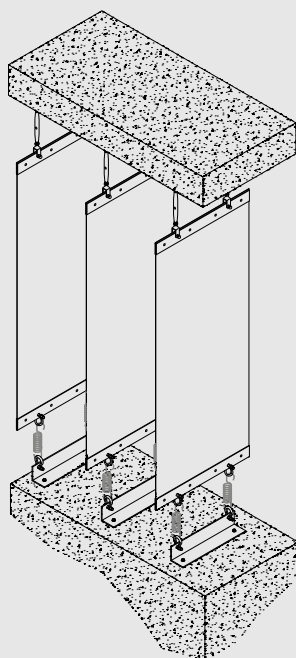
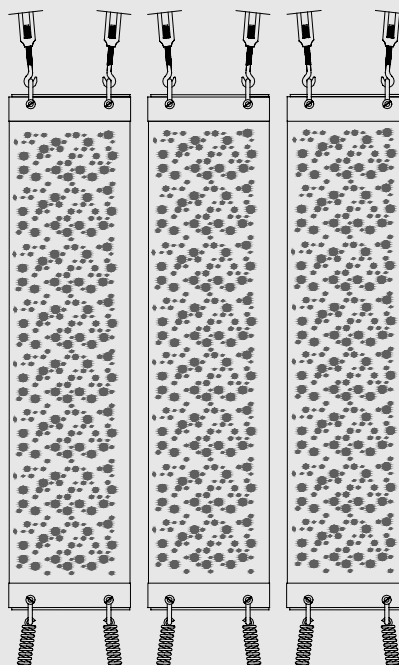

### ESQUEMAS DE INSTALACIÓN



INSTALACIÓN FLEJES PARALELOS

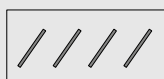

INSTALACIÓN FLEJES INCLINADOS

### FRONTAL VIEW

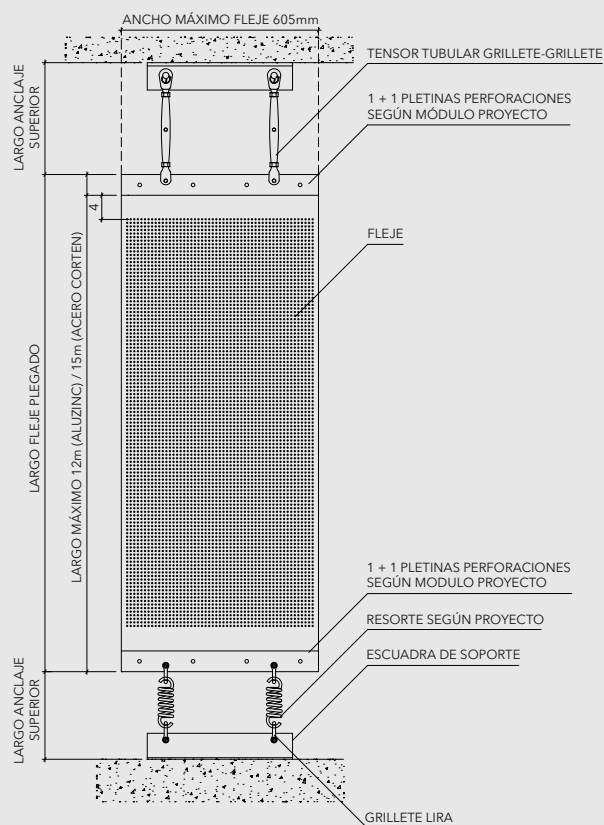

Note: The components of this product are constantly being improved and developed, so modifications may be made. The measurements listed on this Technical Sheet are expressed in millimeters (mm). In order to ensure that the product works correctly, the installation should always be handled by an authorized distributor using all of the accessories listed and in accordance with Hunter Douglas technical specifications.

# SCREENPANEL





OS CAPITALES

# SCREENPANEL

Solar Control | Screen panels

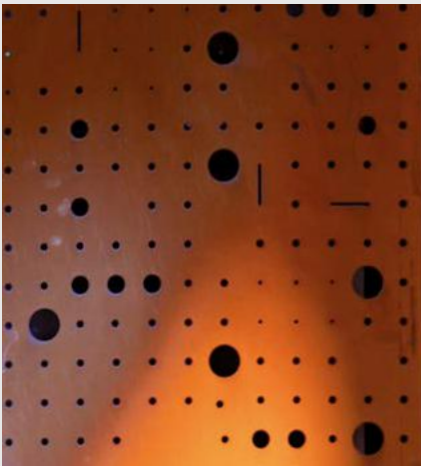
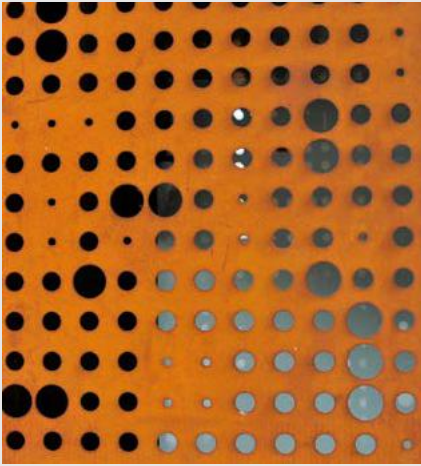

ScreenPanel is a single skin product with a single metal skin that can be used to cover façades. It can be installed vertically or horizontally. This product is unique because it can be perforated using numerical control technology based on the designs of figures that the client can create or random perforated, which offers excellent flexibility. There are four versions of ScreenPanel depending on the application type:

- ScreenPanel G: Vertical application closed joint
- ScreenPanel J: Horizontal application closed joint
- ScreenPanel C: Vertical or horizontal application with 10 mm open joint
- ScreenPanel XL: Large-format application in aluminum
- ScreenPanel XL-W: Large-format application in aluminum or galvanized steel with W-shaped panel

SCREENPANEL G

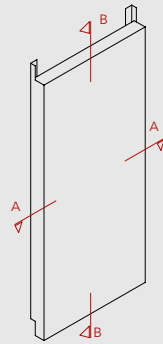

CROSS SECTION VIEW

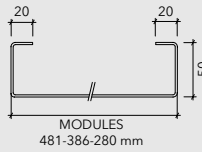

CROSS SECTION VIEW B-B

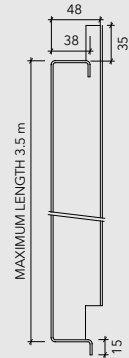

SCREENPANEL J

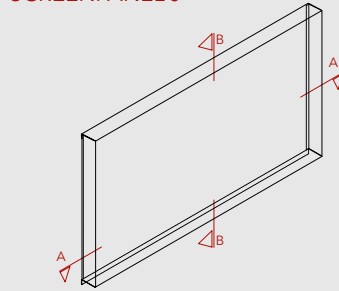

CROSS SECTION VIEW A-A

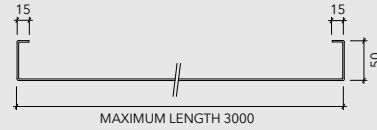

CROSS SECTION VIEW B-B

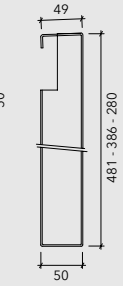

SCREENPANEL C

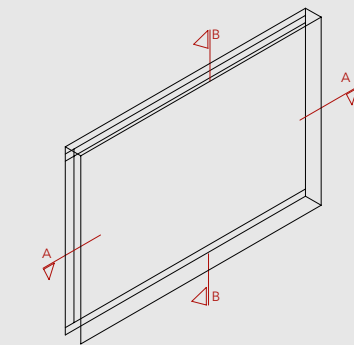

CROSS SECTION VIEW A-A

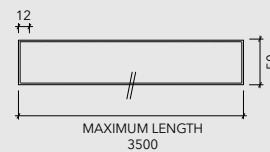

CROSS SECTION VIEW B-B

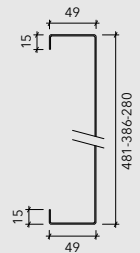

SCREENPANEL XL

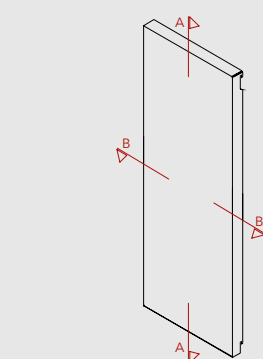

CROSS SECTION VIEW A-A



CROSS SECTION VIEW B-B

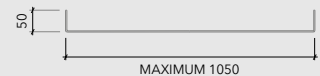



# INSTALLATION

## SCREENPANEL G

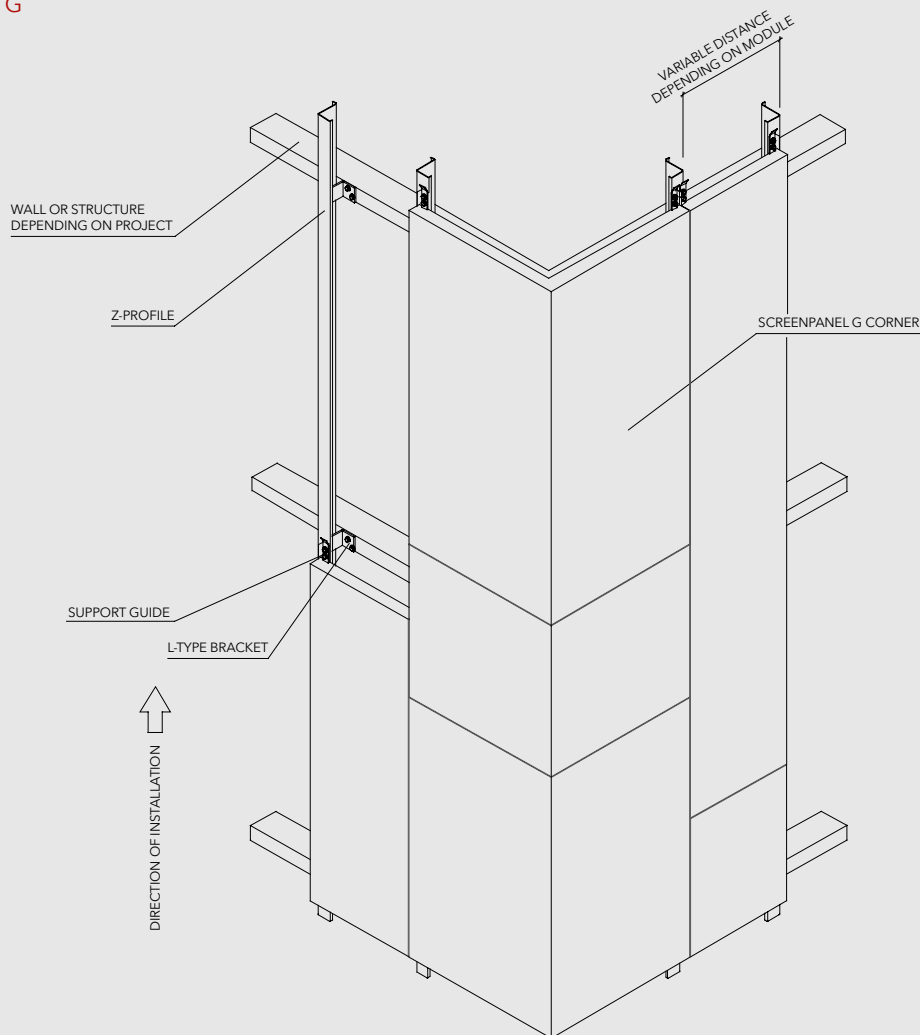

## COMPONENTS

**L - TYPE BRACKET**  
GALVANIZED STEEL 3 mm

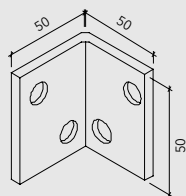

**SCREENPANEL Z PROFILE**  
ZINC-ALUMINUM 1.5 mm

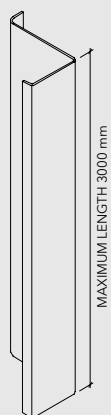
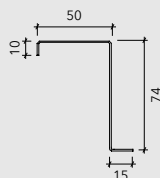

**SCREENPANEL GUIDE BRACKET**  
ZINC-ALUMINUM 2 mm

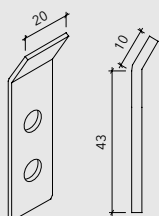

# SCREENPANEL

Solar Control | Screen panels





# SCREENPANEL J

Solar Control | Screen panels

## INSTALLATION

### SCREENPANEL J

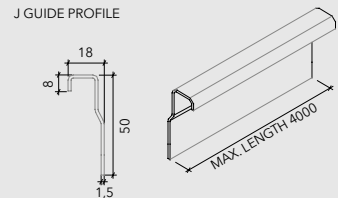
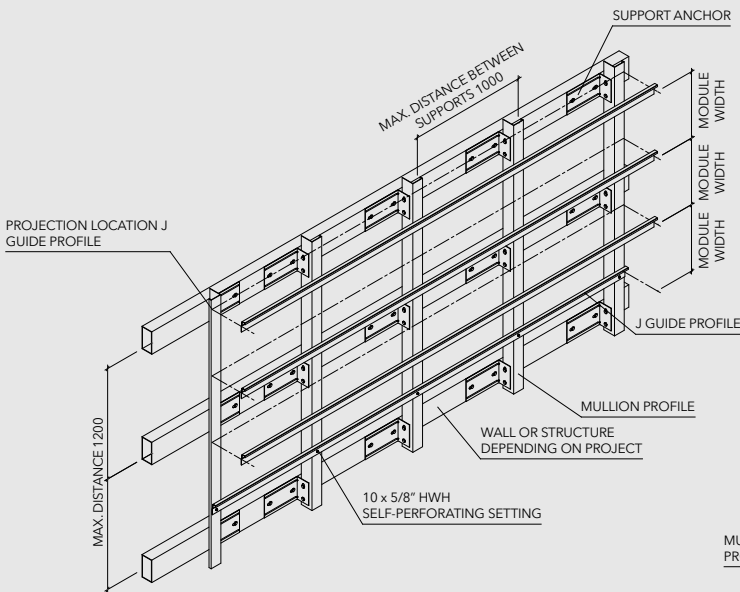
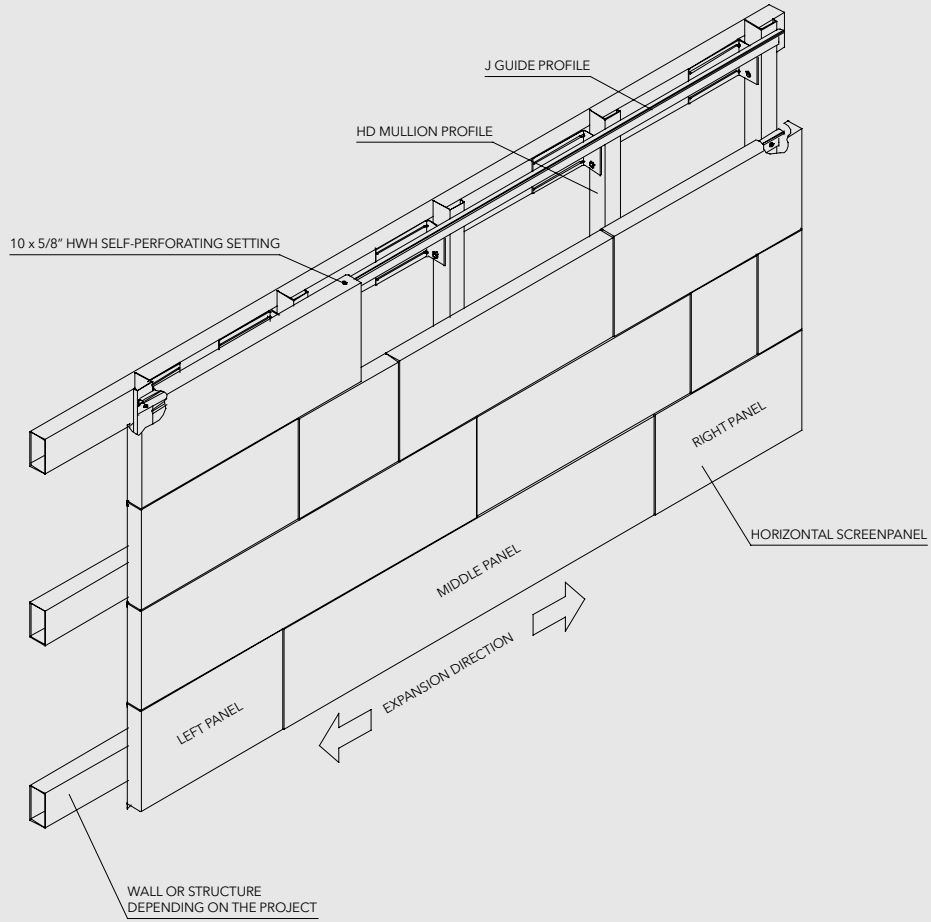

J GUIDE PROFILE

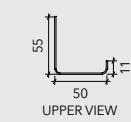

ZINC-ALUMINUM MULLION PROFILE  
UPPER VIEW



ZINC-ALUMINUM SUPPORT ANCHOR  
1.2 mm

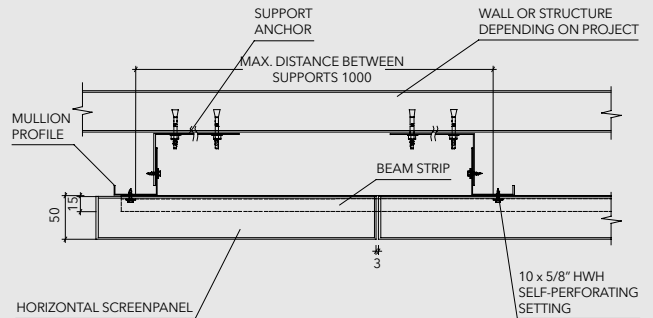

SCREENPANEL C

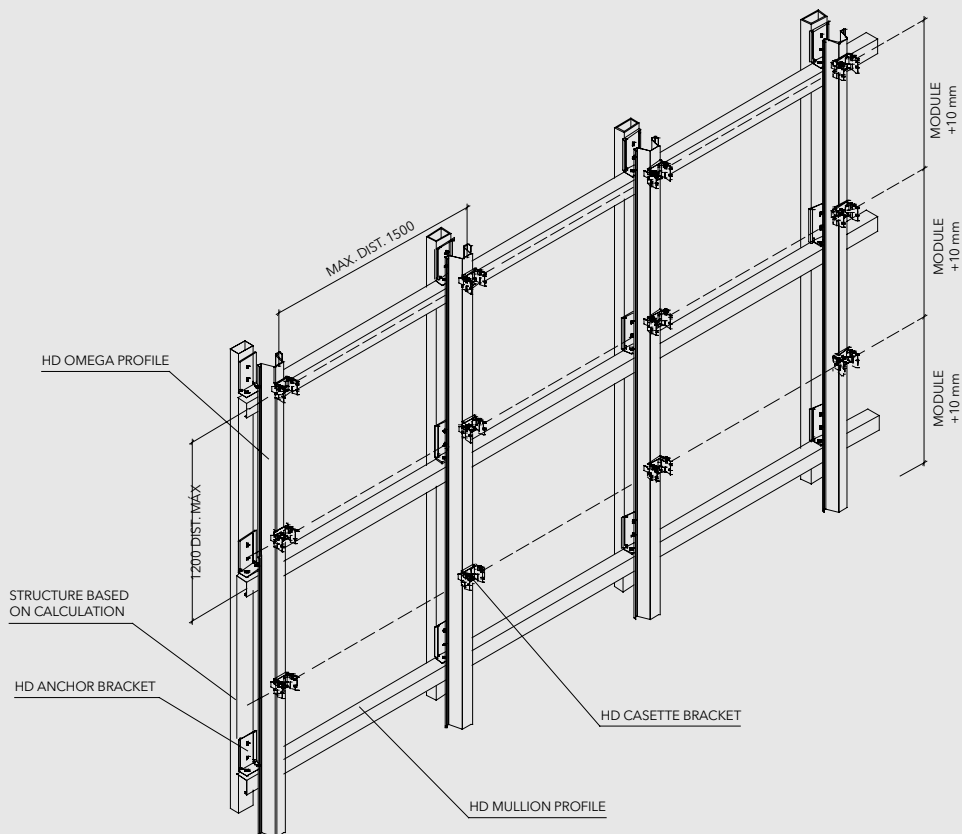

COMPONENTS

1,6 mm GALVANIZED STEEL CASSETTE SCREENPANEL BRACKET

8 mm PLASTIC GUIDE

1,2 ZINC/ALUMINUM

UPPER VIEW

FRONTAL VIEW

SIDE VIEW

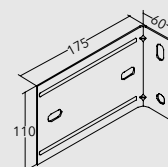
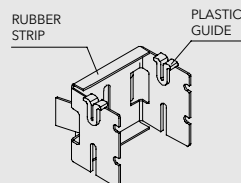
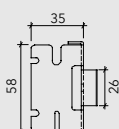
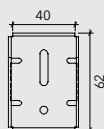
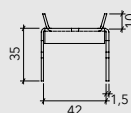

OMEGA PROFILE HD GALVANIZED STEEL 0,85 mm

HD MULLION PROFILE ALUZINC

VERTICAL INSTALLATION SCREENPANEL C ISOMETRIC CENTRAL PANEL SUPPORT

UPPER VIEW

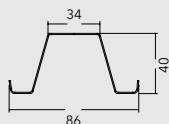

UPPER VIEW

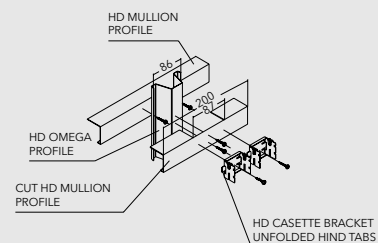
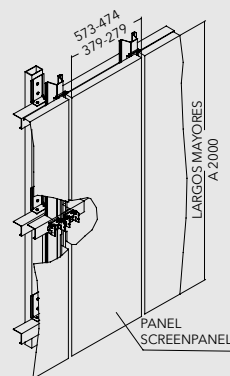

PERFORATIONS

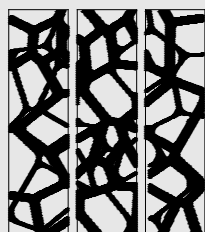

PERFORATION PATTERN BASED ON IMAGES

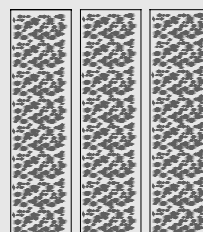

420 RANDOM PERFORATION PATTERN

# SCREENPANEL

Solar Control | Screen panels





# SCREENPANEL XL

Solar Control | Screen panels

## INSTALLATION

### SCREENPANEL XL

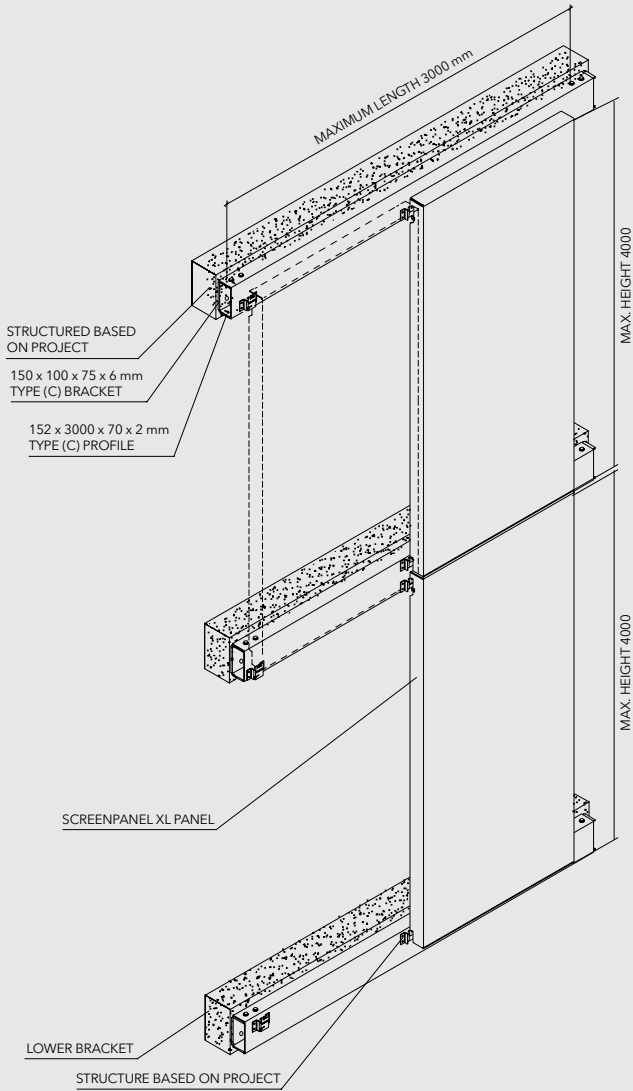

### CLOSED JOINT ALTERNATIVE

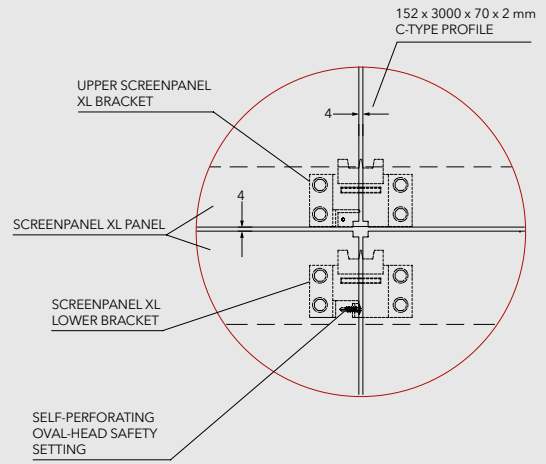

### OPEN JOINT ALTERNATIVE

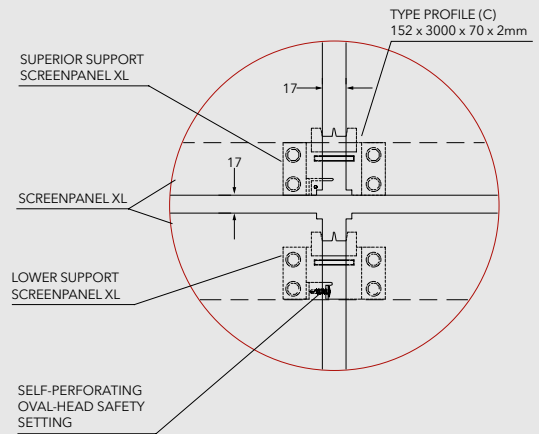

## COMPONENTS

"C"-TYPE BRACKET 6 mm GALVANIZED STEEL

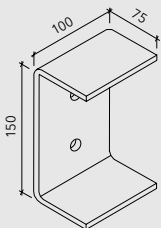

"C"-TYPE PROFILE 2 mm GALVANIZED STEEL

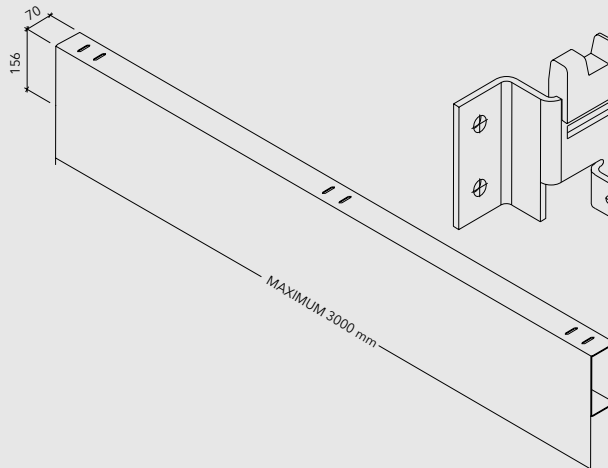

UPPER BRACKET

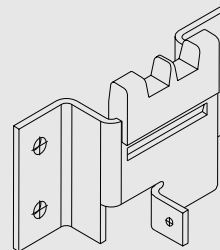

LOWER BRACKET 2,5 mm GALVANIZED STEEL

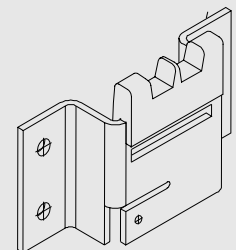



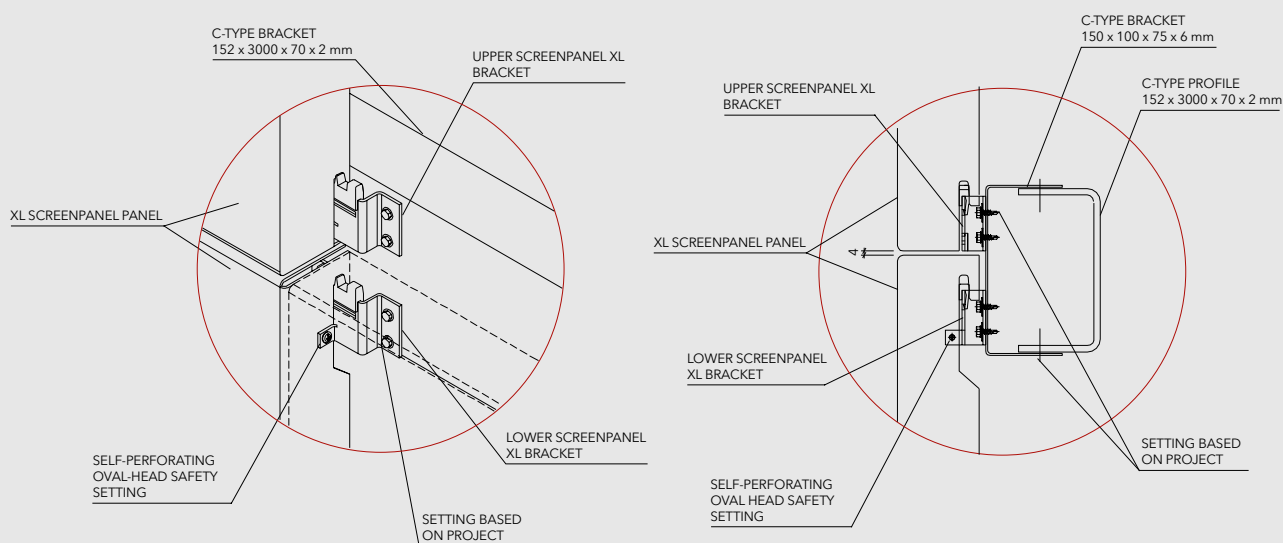

## TECHNICAL DESCRIPTION

### Other Screenpanel information

#### SCREENPANEL G, J and C

PRODUCT	EDGE TO EDGE MODULE (mm)	CENTER TO CENTER MODULE (mm)	ZINC-ALUMINUM (thickness in mm)	ALUMINUM (thickness in mm)	COPPER (thickness in mm)	WEATHERING STEEL (thickness in mm)	WEIGHT (AZ) (kg/m <sup>2</sup> )
SCREENPANEL G/J	481	484	0,8 - 1	1,2 - 1,5	1 - 1,5	1,9	14,6
	386	389	0,8 - 1	1,2 - 1,5	1 - 1,5	1	11,4
	280	283	0,8 - 1	1,2 - 1,5	1 - 1,5	1	10,0
SCREENPANEL C	481	491	0,8 - 1	1,2 - 1,5	1 - 1,5	1,9	14,6
	386	396	0,8 - 1	1,2 - 1,5	1 - 1,5	1	11,4
	280	290	0,8 - 1	1,2 - 1,5	1 - 1,5	1	10,0

Note: The thickness will depend on the type of perforation and open area of the panel.

#### SCREENPANEL XL AND XL W

PRODUCT	MATERIAL	MAX. LENGTH (mm)	MAX. MODULE (mm)	THICKNESS (mm)
SCREENPANEL XL	ALUMINUM	4000	1050	3
	GALVANIZED STEEL			2

- ScreenPanel G, J, C Colors: over 100 standard colors and custom colors available
- ScreenPanel XL Colors: based on the powder coating color chart
- Finish: smooth or perforated
- Uses: cladding, sunscreen
- Maximum Length: ScreenPanel J: 3 m  
ScreenPanel C and G: 3,5 m  
ScreenPanel XL: 3,5 m
- Yield: varies depending on module
- Other available materials: zinc-aluminum, weathering steel, aluminum and copper

# SCREENPANEL XL W

Solar Control | Screen panels

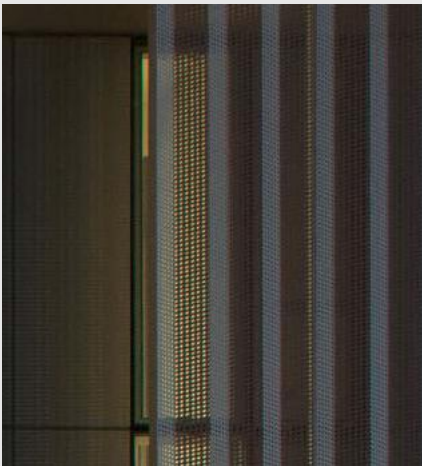
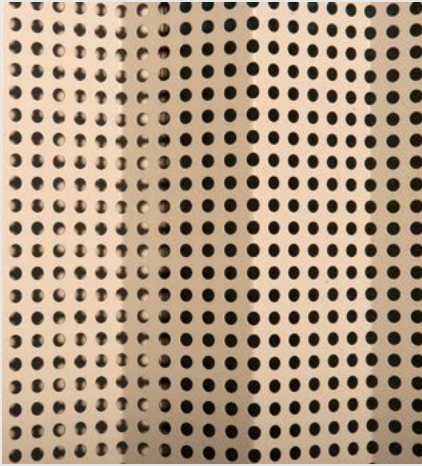

Screenpanel XL-W is a single-skin product that can be used in double skin façades. It is installed vertically and is composed of a thick aluminum sheet folded in isosceles triangles in various modules 880 mm module with a maximum size of 1200 mm. Up to 45% of the open area of this product can be perforated in one or two triangular faces.

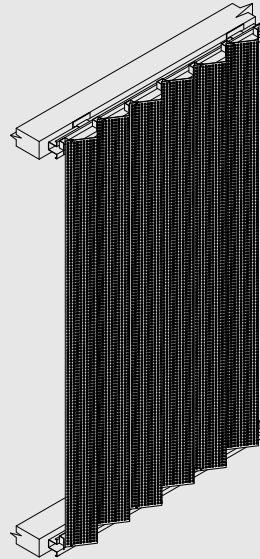

## TECHNICAL DESCRIPTION

PRODUCT	MATERIAL	MODULE (mm)		THICKNESS (mm)	WEIGHT (kg/m <sup>2</sup> )
SCREENPANEL XL-W LOUVRE	ALUMINUM	3500	880	3	11

- Material: Aluminum (galvanized steel)
- Thickness: 2 - 3 mm
- Uses: Vertical louver and second skin
- Finish: Perforated or smooth
- Yield: Varies by module
- Module maximum: 3500 x 880 mm
- Colors: Based on powder coating color chart

## COMPONENTS

### OMEGA PROFILE (OUTSIDE OF SLAB)

2 mm galvanized steel  
Electrostatic powder paint

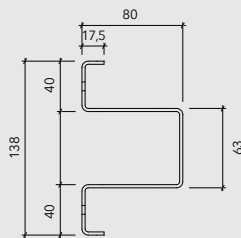

### BRACKET

2 mm galvanized steel  
Electrostatic powder paint

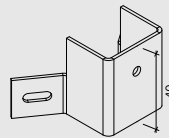

### LEVELING BRACKET

Galvanized steel  
Electrostatic powder paint

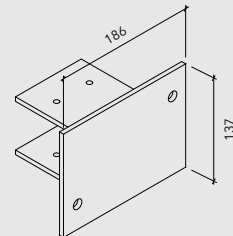

## TYPE OF MODULATION

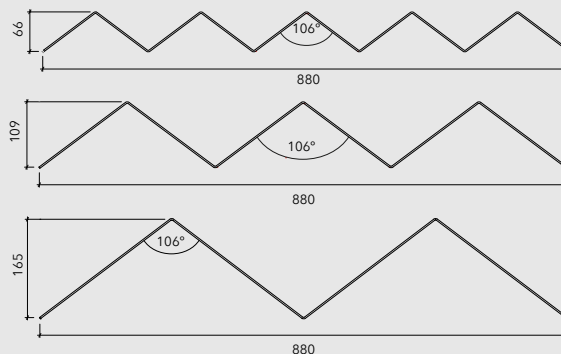

For other modulations, contact the technical department.

## INSTALLATION

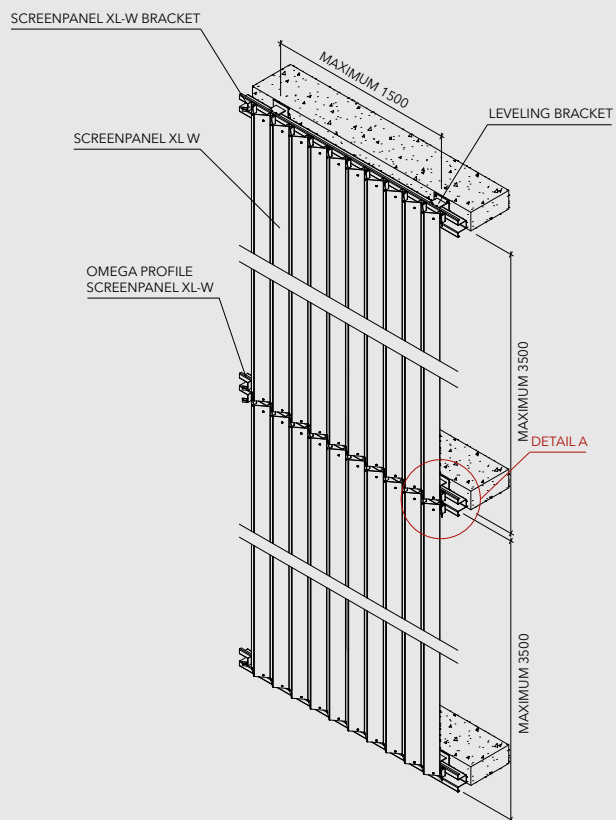

DETAIL A

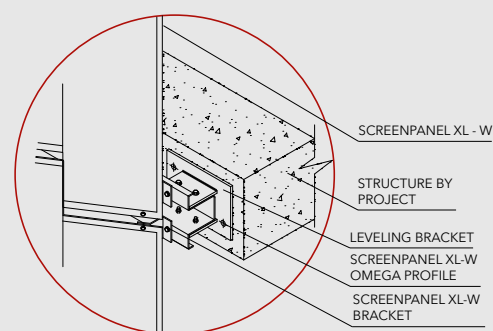

PLANT VIEW FRONT SOLUTION

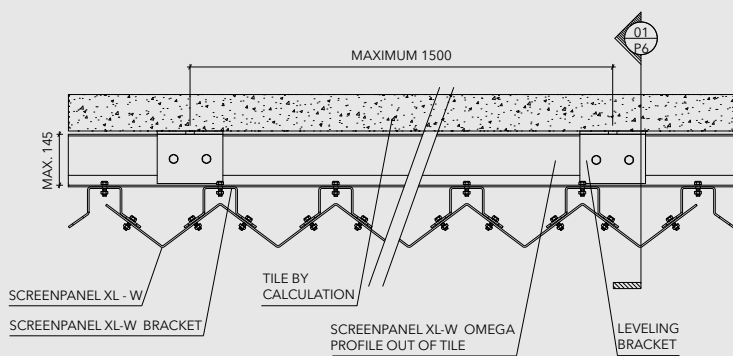

UPPER PANEL

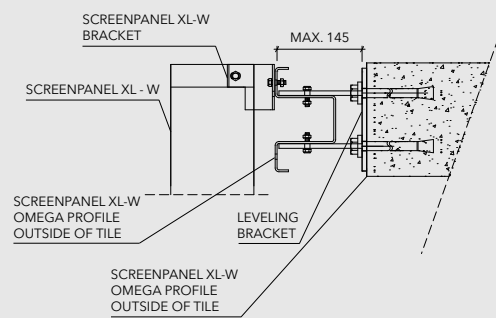

OPEN JOINT BETWEEN 2 PANELS DETAIL

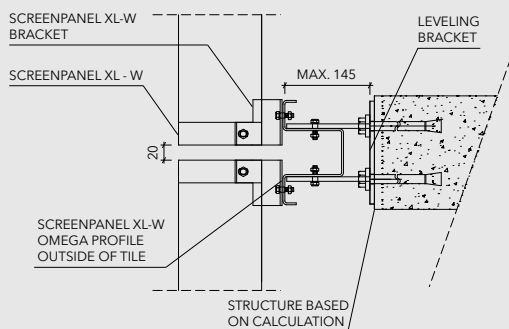

LOWER PANEL

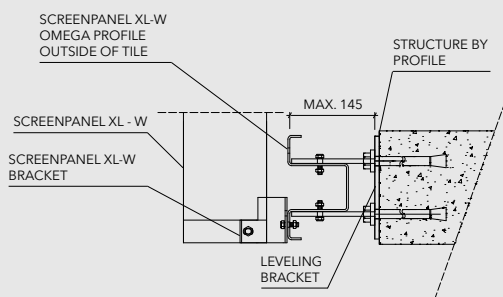

Note: The components of this product are constantly being improved and developed, so modifications may be made. The measurements listed on this Technical Sheet are expressed in millimeters (mm). In order to ensure that the product works correctly, the installation should always be handled by an authorized distributor using all of the accessories listed and in accordance with Hunter Douglas technical specifications.

# SCREENPANEL XL

Solar Control | Screen panels





# SOFTWAVE 25 - 50





# SOFTWAVE 25 - 50

Solar Control | Screen panels

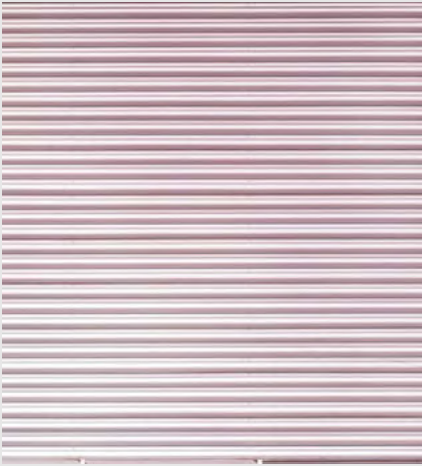

Softwave 25-50 panels have been designed to be used as metal claddings. They have a unique geometry that mainly responds to aesthetic requirements expressed in panels of curved lines. They are available in smooth and perforated styles (with four standard patterns). When these panels are perforated, they can be used as a solar control element. They can be installed on façades with the vertical or horizontal waves. The splice is made with a tongue-and-groove joint and is affixed to the structure on the smooth part. For unaligned or uneven structures, an auxiliary structure based on Hunter Douglas mullion sections should be considered.



## TECHNICAL DESCRIPTION

PRODUCT	MATERIAL	THICKNESS (mm)	WEIGHT kg/m <sup>2</sup>	YIELD panels/m <sup>2</sup>
SOFTWAVE 25	ZINC-ALUMINUM	0,5	5,76	3,63
		0,6	6,91	
SOFTWAVE 50	ZINC-ALUMINUM	0,5	5,61	2,33
		0,6	6,73	

- Colors: Over 100 standard colors and custom colors available as well as woodgrains or mineral grains
- Finish: Smooth or perforated
- Uses: Cladding, sun control
- Lengths: Based on the project requirements. We recommend not exceeding 8 m
- Other materials available: Weathering steel, aluminum, copper and zinc

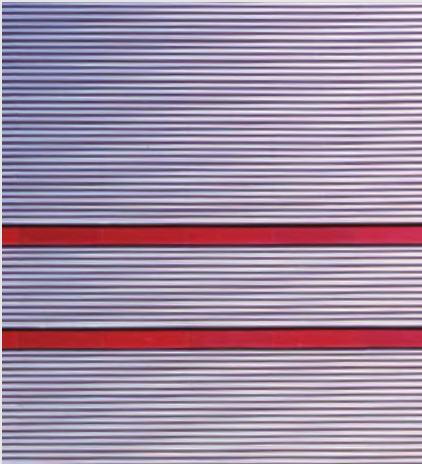

### OPTION WITH OPEN JOINT

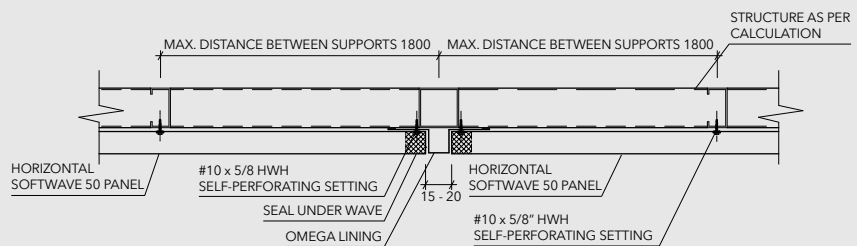

### OPTION WITH STONEMWORK

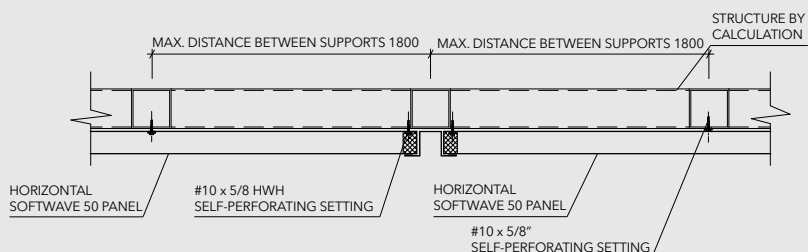



## INSTALLATION

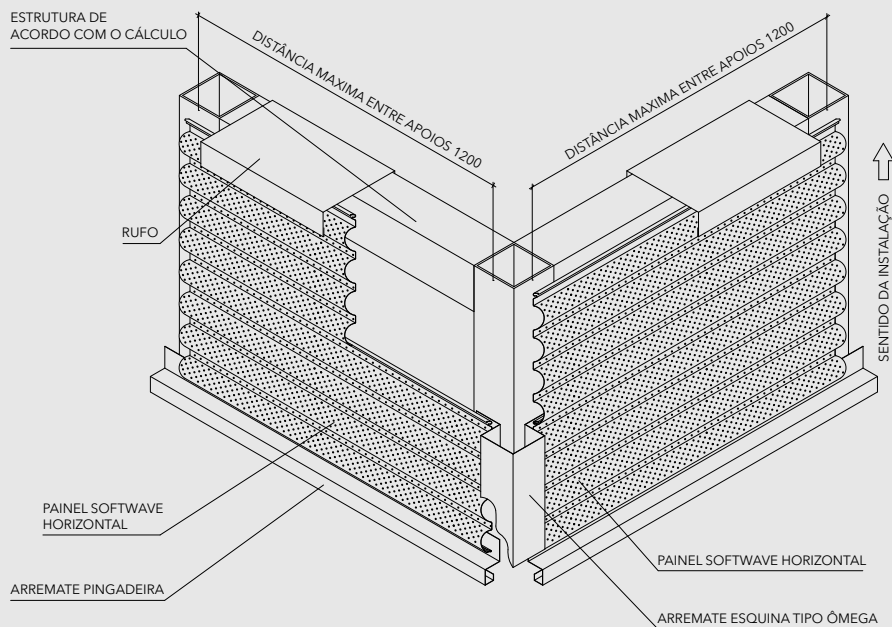

UPPER FRONTAL DETAIL HORIZONTAL SOFTWAVE 25 - 50 PANEL

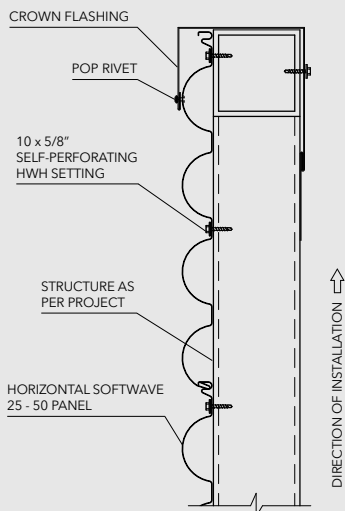

LOWER DETAIL HORIZONTAL SOFTWAVE 25 - 50 PANEL

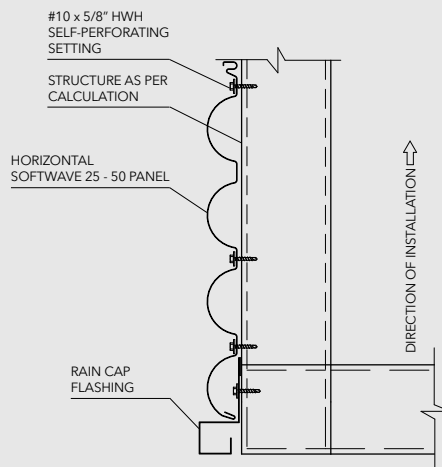

## STANDARD PERFORATIONS

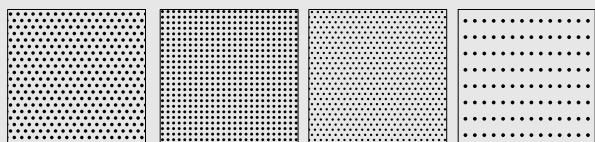

# 103	# 106	# 118	# 118 M2
Ø 3 mm	Ø 2,5 mm	Ø 2 mm	Ø 2 mm
20% open	16% open	15% open	7,3% open
6,35 mm	5,5 mm	8,6 mm	3 mm
5,5 mm	5,5 mm	5 mm	6,6 mm

Consult the perforations annex for other perforations.

Note: The components of this product are constantly being improved and developed, so modifications may be made. The measurements listed on this Technical Sheet are expressed in millimeters (mm). In order to ensure that the product works correctly, the installation should always be handled by an authorized distributor using all of the accessories listed and in accordance with Hunter Douglas technical specifications.

# QUADROLINES

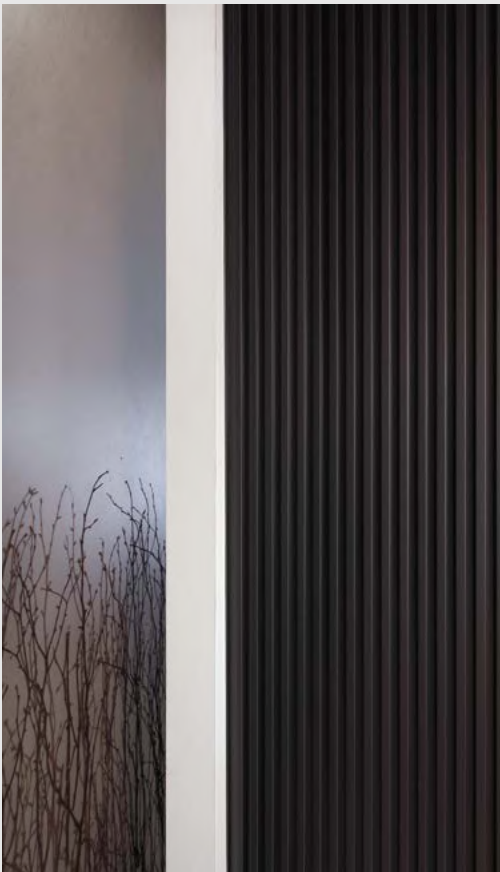



# QUADROLINES 30 x 15 - 15 x 10

Solar Control | Screen panels



The Quadrolines 30 x 15 and 15 x 10 panels have been designed for the cladding façades, providing a continuous and homogenous format with noteworthy geometry. It can be installed with horizontal or vertical lines, which makes it very versatile. It provides excellent sun control when installed in front of glass with a perforated panel option.

## TECHNICAL DESCRIPTION

### TABLE OF WEIGHTS

PRODUCT	MATERIAL	THICKNESS (mm)	WEIGHT (kg/m <sup>2</sup> )	YIELD (panels / m <sup>2</sup> )	MAXIMUM LENGTH (m)
QUADROLINES 30 x 15	ZINC-ALUMINUM	0,5	6,7	2,6	6
QUADROLINES 15 x 10	ZINC-ALUMINUM	0,5	6,7	5,55	6

- Use: Façades, sun control
- Finish: Smooth, perforated, wood grains or mineral grains
- Colors: Over 100 standard colors and custom colors available
- Other materials available: Weathering steel (only for 30 x 15), aluminum, copper and zinc



### QUADROLINES 15 x 10 PANEL SECTION

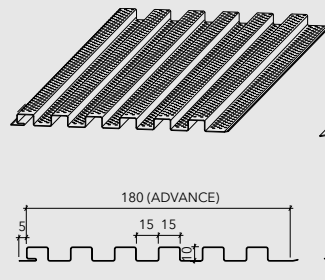

### QUADROLINES 30 x 15 PANEL SECTION

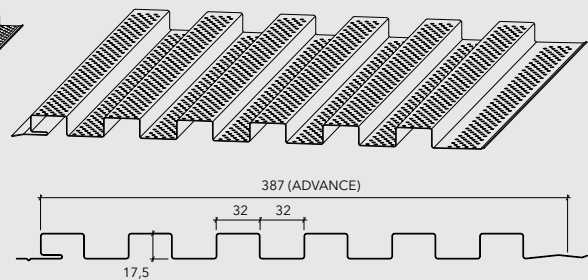

## ASSEMBLY

The installation of Quadrolines 15 x 10 panels is based on a tongue-and-groove system. The 30 x 15 panel is affixed directly to a fiberboard sheet or metallic structure, reducing its distance to the structure, which allows for a homogeneous format without exposed joints or attachments. For Quadrolines 15 x 10, the "C" panel carrier is designed for applications on interior walls and curved surfaces. The "V" panel carrier option is mainly used for façades and ceilings.

### "C" PANEL CARRIER

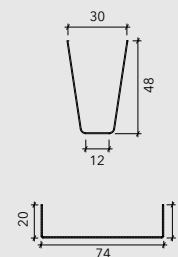
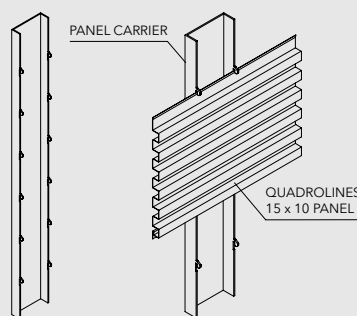

"C" PANEL CARRIER SECTION  
LENGTH: 5000 mm  
THICKNESS: 0.8 mm

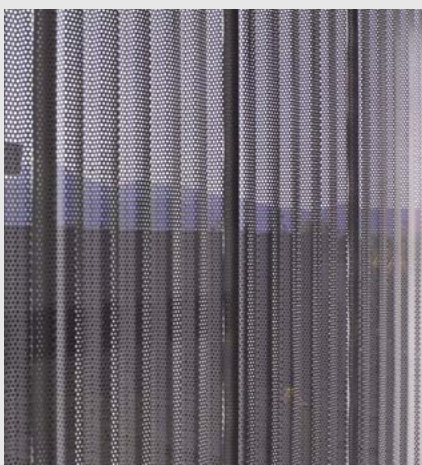
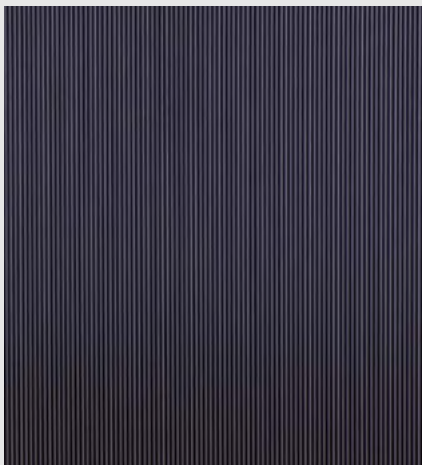

## STANDARD PERFORATIONS

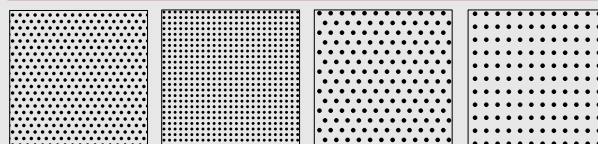

# 103 Ø 3 mm 20% open 6,35 mm 5,5 mm	# 106 Ø 2,5 mm 16% open 5,5 mm 5,5 mm	# 110-M1 Ø 3,9 mm 21% open 9,53 mm 8,25 mm	# 110-M3 Ø 3,9 mm 21% open 9,53 mm 11 mm
--	---	--	--

## INSTALLATION

### VERTICAL INSTALLATION

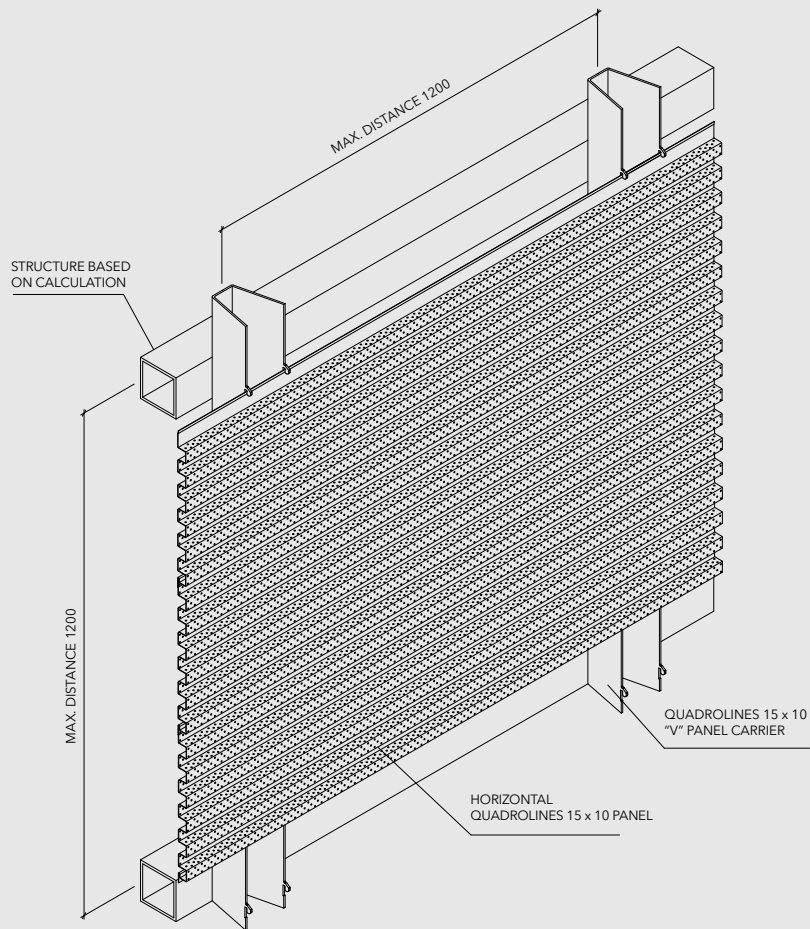

### CROSECTION VIEW A-A

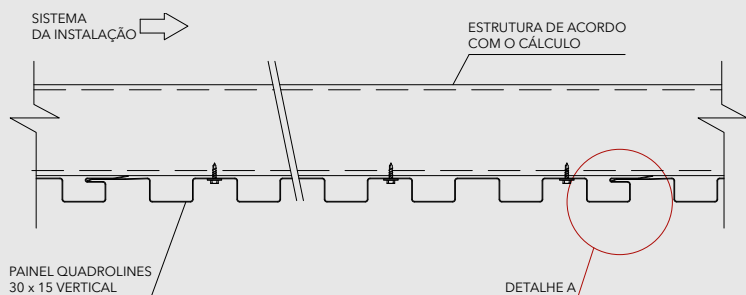

### DETAIL A TONGUE & GROOVE

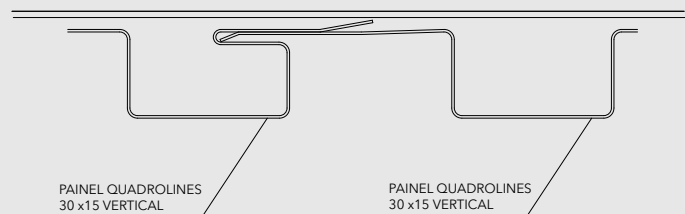

### VERTICAL QUADROLINES 30 x 15

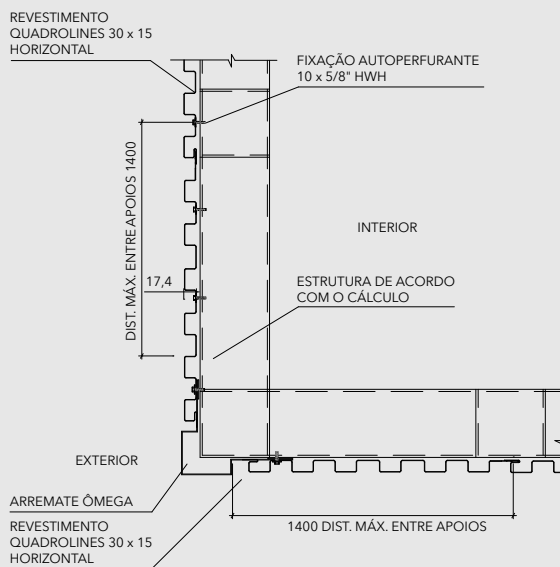

Note: The components of this product are constantly being improved and developed, so modifications may be made. The measurements listed on this Technical Sheet are expressed in millimeters (mm). In order to ensure that the product works correctly, the installation should always be handled by an authorized distributor using all of the accessories listed and in accordance with Hunter Douglas technical specifications.





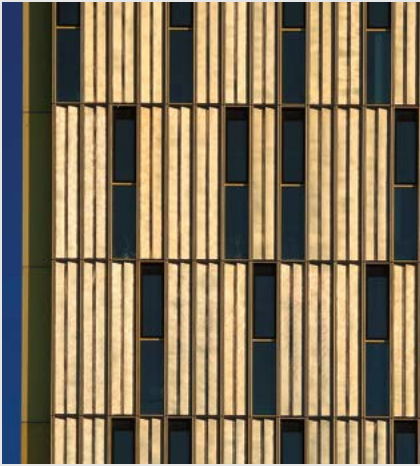

GKD, the German firm that is the global leader in the manufacture of stainless steel mesh, and Hunter Douglas have teamed up to create this line of architectural mesh which is now being made in Chile.

GKD meshes have a textile, ductile and flexible structure that is also resistant and robust and can be used to cover or shade buildings, walls and ceilings.

The meshes have different percentages of open area depending on the weave so that they can be seen through from the inside and outside. They contribute to sun protection when used on a façade and provide attractive solutions because they can be backlit or frontlighted.

## TECHNICAL DESCRIPTION

- GKD mesh types: Lago, Sambesi, Tigres, Escale 10 x 1, Lamelle
- Material: Stainless steel (vertical threads), stainless steel (horizontal bars)
- Mesh types: Minitubrise, M Profile, Escale 10 x 1
- Materials: Stainless steel (vertical threads), zinc-aluminum (horizontal bars)
- Thickness: Cable and rod width vary depending on the mesh type
- Uses: Surfacing for exteriors and interiors, ceilings, sun protection, etc.
- Standard width: Varies by type of mesh
- Maximum length: Continuous, by project
- Mesh colors: Available in over 100 colors as well as wood grains and mineral grains for zinc-aluminum (only Escale, Minitubrise and M profile)



## MESH LAYOUT

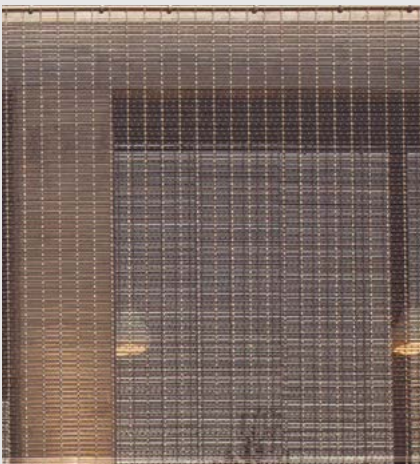
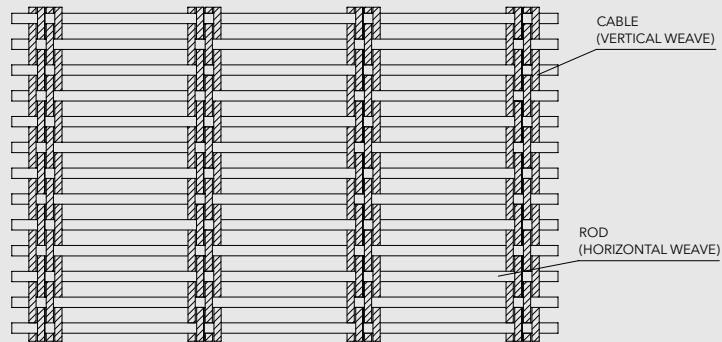



## MESH TYPES

### HYBRID

#### MINITUBRISE

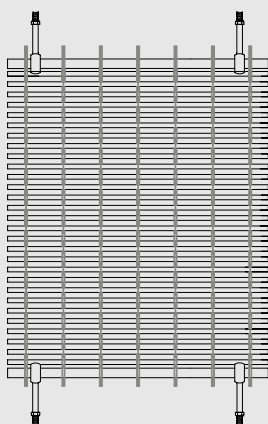

Material: zinc-aluminum  
Open area: 50%  
ø tube: 9 mm  
ø cable: 3 x 2 mm  
AISI cable

Cable pitch: 80 mm  
Bar pitch: 18 mm  
Mesh thickness: 14 mm  
Weight: 6,2 kg/m<sup>2</sup>

#### M PROFILE

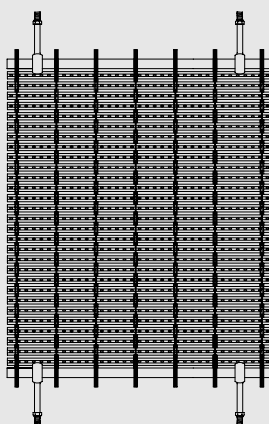

Material: zinc-aluminum  
Open area: 50%  
M profile width: 15 mm  
ø cable: 3 x 2 mm  
AISI cable

Cable pitch: 80 mm  
Bar pitch: 22 mm  
Mesh thickness: 9 mm  
Weight: 2,6 kg/m<sup>2</sup>

#### ESCALE 10 X 1

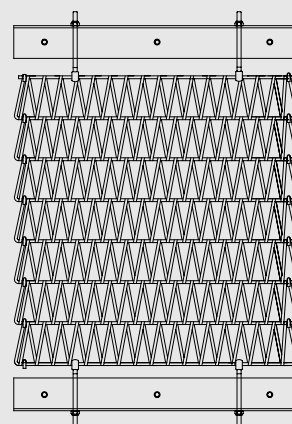

Material: galvanized steel  
Open area: 50%  
ø bar: 8 mm  
Spiral: 10 x 1 mm

Spiral pitch: 30 mm  
Bar pitch: 100 mm  
Mesh thickness: 22 mm  
Weight: 11,5 kg/m<sup>2</sup>

### GKD

#### LAMELLE

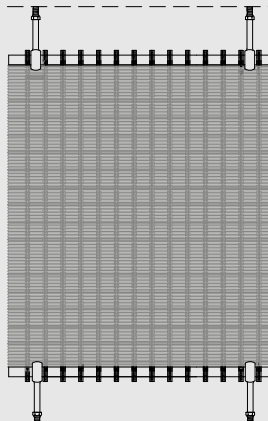

Material: stainless steel  
Open area: 44,3%  
ø rod: 1,5 mm  
ø cable: 4 x 0,75 mm  
Cable duct: 26,4 mm

Weave pitch: 3 mm  
Mesh thickness: 3 mm  
Weight: 5,2 kg/m<sup>2</sup>  
Mesh width: 3,65 m

#### LAGO

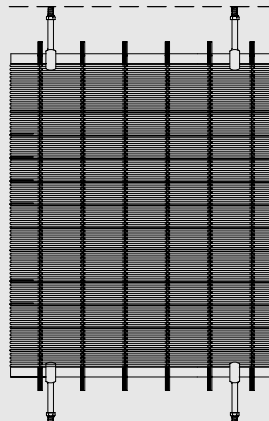

Material: stainless steel  
Open area: 44%  
ø rod: 2 mm  
ø cable: 4 x 1 mm  
Cable duct: 36 mm

Weave pitch: 4 mm  
Mesh thickness: 3,5 mm  
Weight: 6,8 kg/m<sup>2</sup>  
Mesh width: 3,63 m

#### TIGRIS

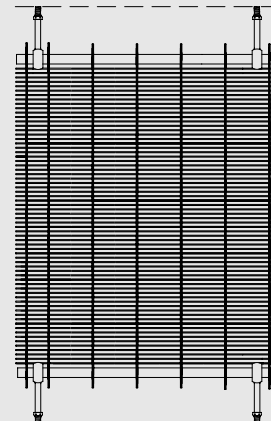

Material: stainless steel  
Open area: 62,1%  
ø rod: 3 mm  
ø cable: 3 x 2 mm  
Cable duct: 80 mm

Weave pitch: 10 mm  
Mesh thickness: 6,2 mm  
Weight: 6 kg/m<sup>2</sup>  
Mesh width: 3,57 m

### SAMBESI

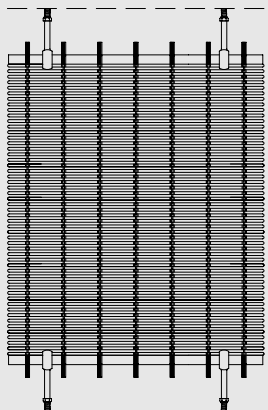

Material: stainless steel  
Open area: 40%  
ø rod: 3 mm  
ø cable: 4 x 2 mm  
Cable duct: 50 mm

Weave pitch: 6 mm  
Mesh thickness: 7 mm  
Weight: 11 kg/m<sup>2</sup>  
Mesh width: 3,60 m

### ESCALE 7 X 1

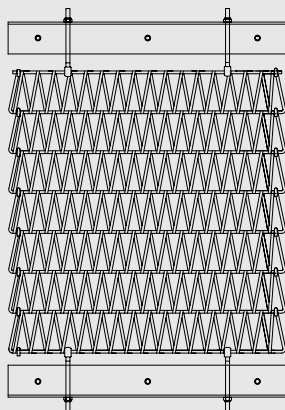

Material: stainless steel  
Open area: 50%  
ø rod: 7 mm  
Spiral: 7 x 1 mm

Spiral pitch: 20 mm  
Rod pitch: 100 mm  
Mesh thickness: 22 mm  
Weight: 8,9 kg/m<sup>2</sup>

Note: The components of this product are constantly being improved and developed, so modifications may be made. The measurements listed on this Technical Sheet are expressed in millimeters (mm). In order to ensure that the product works correctly, the installation should always be handled by an authorized distributor using all of the accessories listed and in accordance with Hunter Douglas technical specifications.





ZIONE PRADA

# ALUSION

Solar Control | Alufoam panels



Alusion products are aluminum foam architectural panels that offer a series of architectural and acoustic solutions for interior and exterior applications. The panels are made by injecting air into molten aluminum which contains a fine dispersion of ceramic particulates that stabilize the bubbles formed by the air.

Alusion is made with up to 20% recycled material and is 100% recyclable. The standard panel size is 1220 x 2440 mm, but it is possible to manufacture special sizes upon request.

Alusion panels are a unique, versatile material with practically unlimited architectural and design applications.

There are three basic versions of Alusion:

- Small Cell
- Mid Cell
- Large Cell

The greater the density, the lower the cell size, which gives the material more mass and mechanical resistance.



The three basic versions are available with three different finishes which provide a different look for each lower and upper panel surface.

- Natural
- Cells open on one side
- Cells open on two sides

Alusion is available in three standard thicknesses:

- 12,7 mm
- 25,4 mm
- 43,2 mm

The Large Cell version of Alusion open on both sides is the only translucent version that allows for backlit applications.



Alusion panels allow for the creation of light and easy-to-install acoustic solutions. Their rear section contains an air chamber and 55 mm mineral wool.

## TECHNICAL DESCRIPTION

PRODUCT	FINISH (mm)	THICKNESS (mm)	NRC*
MID CELL	Open on one side	12,7	0,40
MID CELL	Open on two sides	12,7	0,70
LARGE CELL	Open on one side	25,4	1,00
LARGE CELL	Open on two sides	25,4	0,85
MID CELL	Open on one side	25,4	0,45
MID CELL	Open on two sides	25,4	0,55
LARGE CELL	Open on one side	43,2	0,60
LARGE CELL	Open on two sides	43,2	1,00

\*Noise reduction coefficient  
Includes a 75 mm air chamber and 50 mm rock wool.



## INSTALLATION

NON-REGISTRABLE SYSTEM  
EXTERIOR APPLICATION

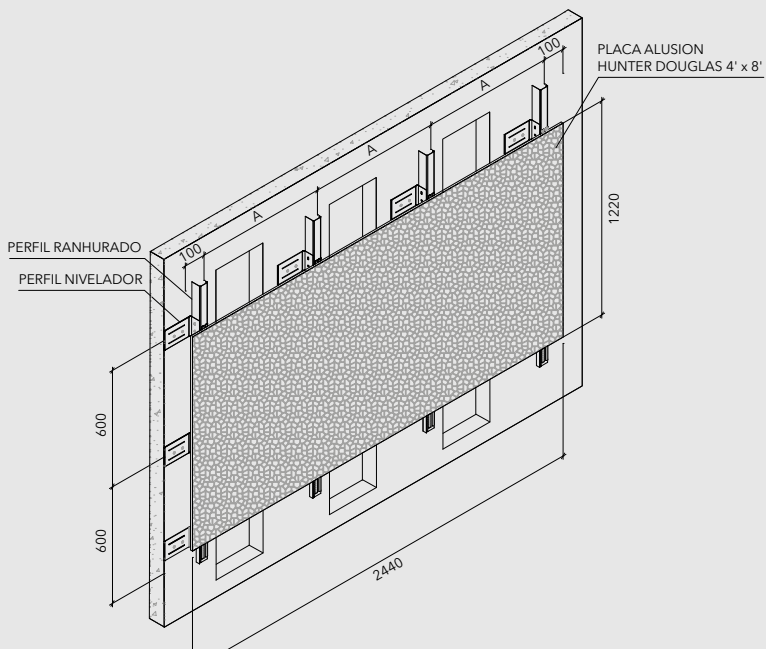

### DETAIL D

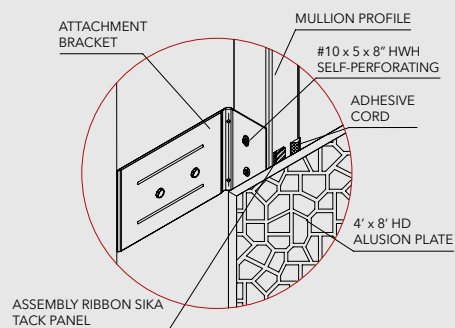

REGISTRABLE SYSTEM

EXTERIOR APPLICATION  
HIDDEN PROFILE, 12.7 mm THICKNESS

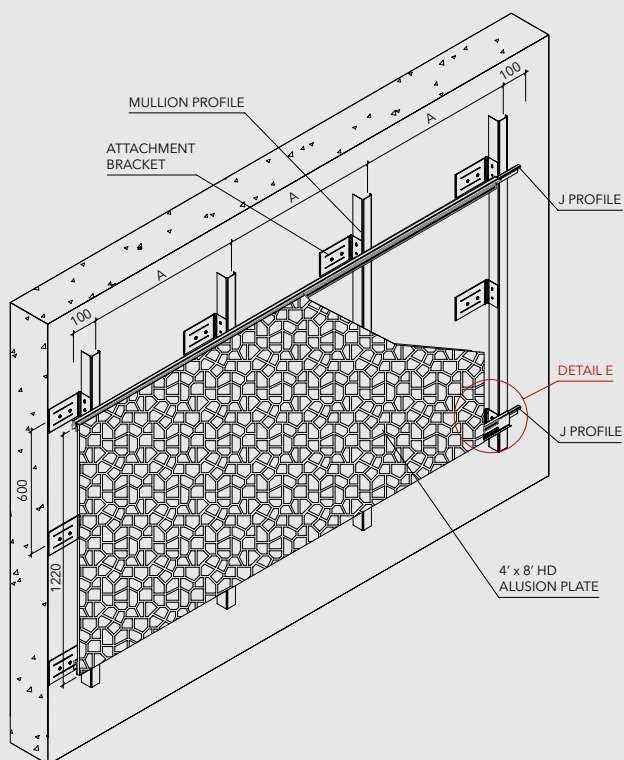

### DETAIL E

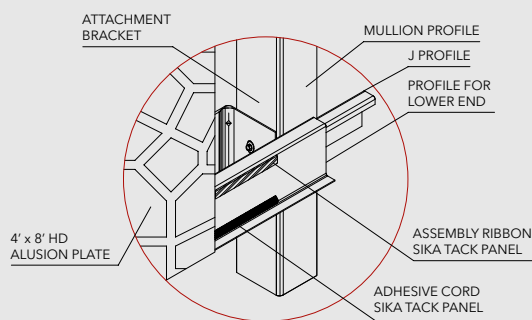

# ALUSION

Solar Control | Alufoam panels



Alusion can be:

- Covered with powder paint according to the Hunter Douglas color chart
- Cut as required by the design using numerical control machines

## APPLICATIONS

Alusion panels can be used for exterior and interior surfacing applications, highlighting the unique characteristics of each panel.

Their contribution to acoustic condition of spaces and backlit applications are also worthy of note. They can also be used for registrable roof applications in multiple formats and backlit. The various Alusion panels can be used in interior and exterior signage, design furniture, retail, hotels, private projects and public buildings.



## TECHNICAL DESCRIPTION

PRODUCT	FINISH (mm)	THICKNESS (mm)			SPACING (A mm)	MATERIAL
LARGE CELL	Natural	12,7	25,4	43,2	1000	ALUMINUM
	Open on one side	12,7	25,4			
	Open on two sides	12,7	25,4	43,2		
MID CELL	Natural	12,7	25,4		800	
	Open on one side	12,7	25,4			
	Open on two sides	12,7	25,4			
SMALL CELL	Natural	12,7	25,4		600	
	Open on one side	12,7	25,4			
	Open on two sides	12,7	25,4			

Note: For other thicknesses, ask the technical department for spacing between supports. All of these spacings are tested for winds up to 70 km/hr.

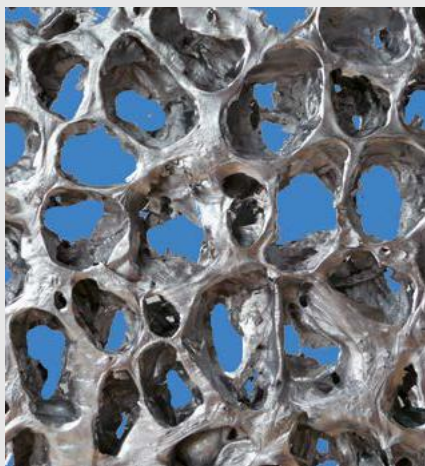

## ALUSION SLIDING SHUTTER

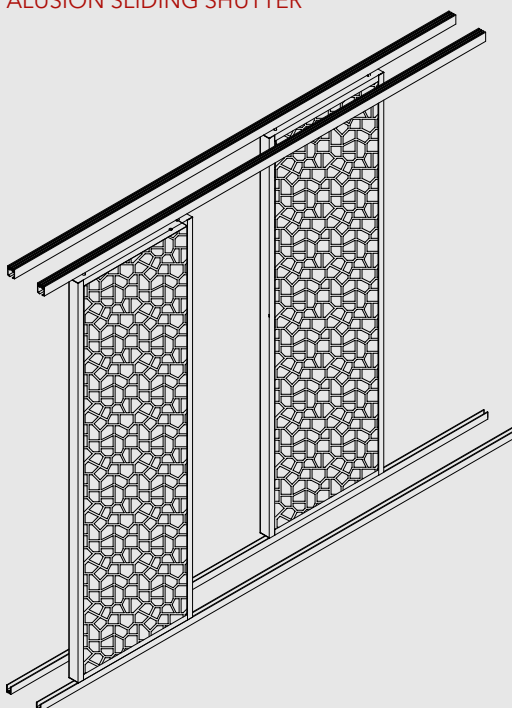



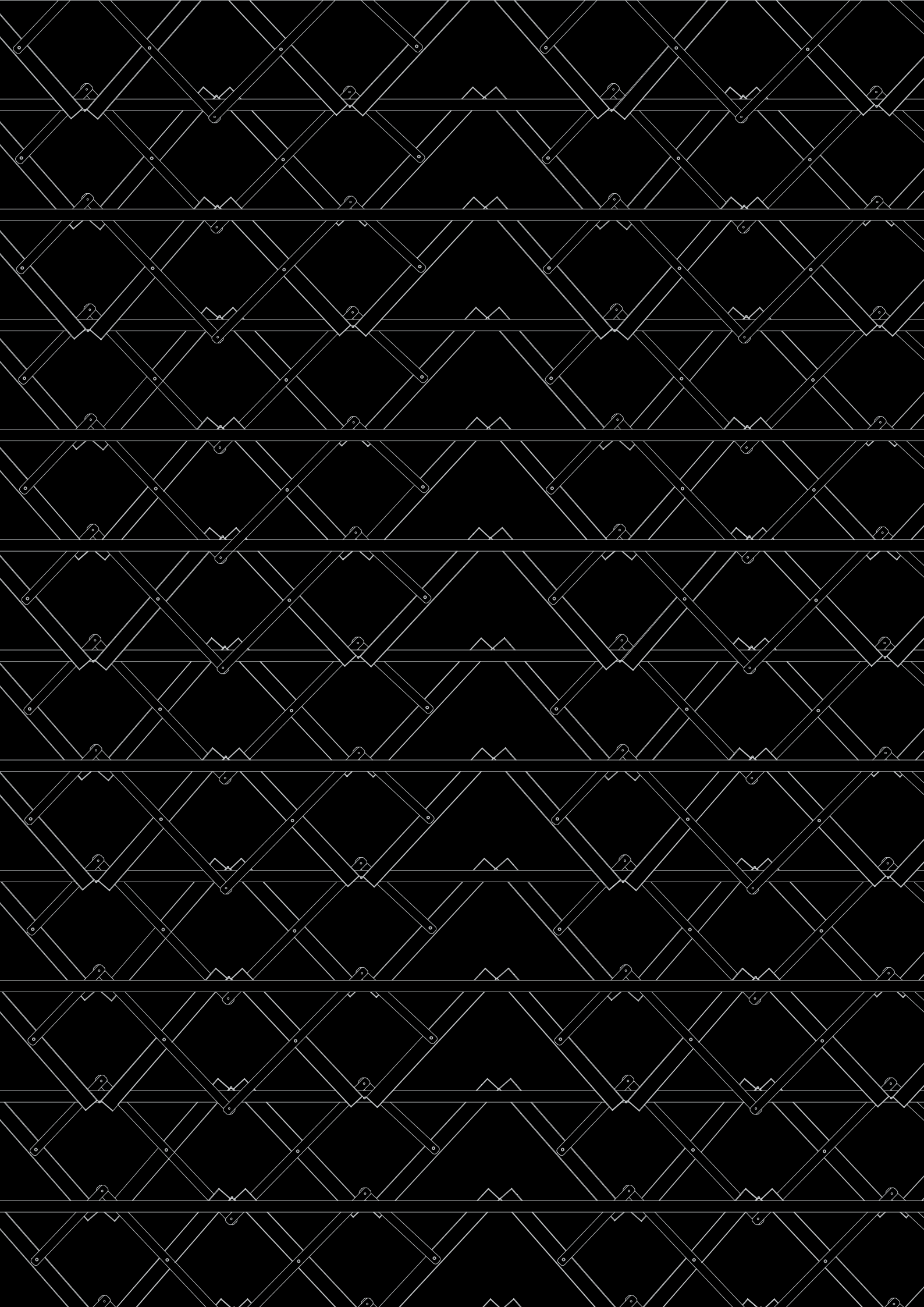



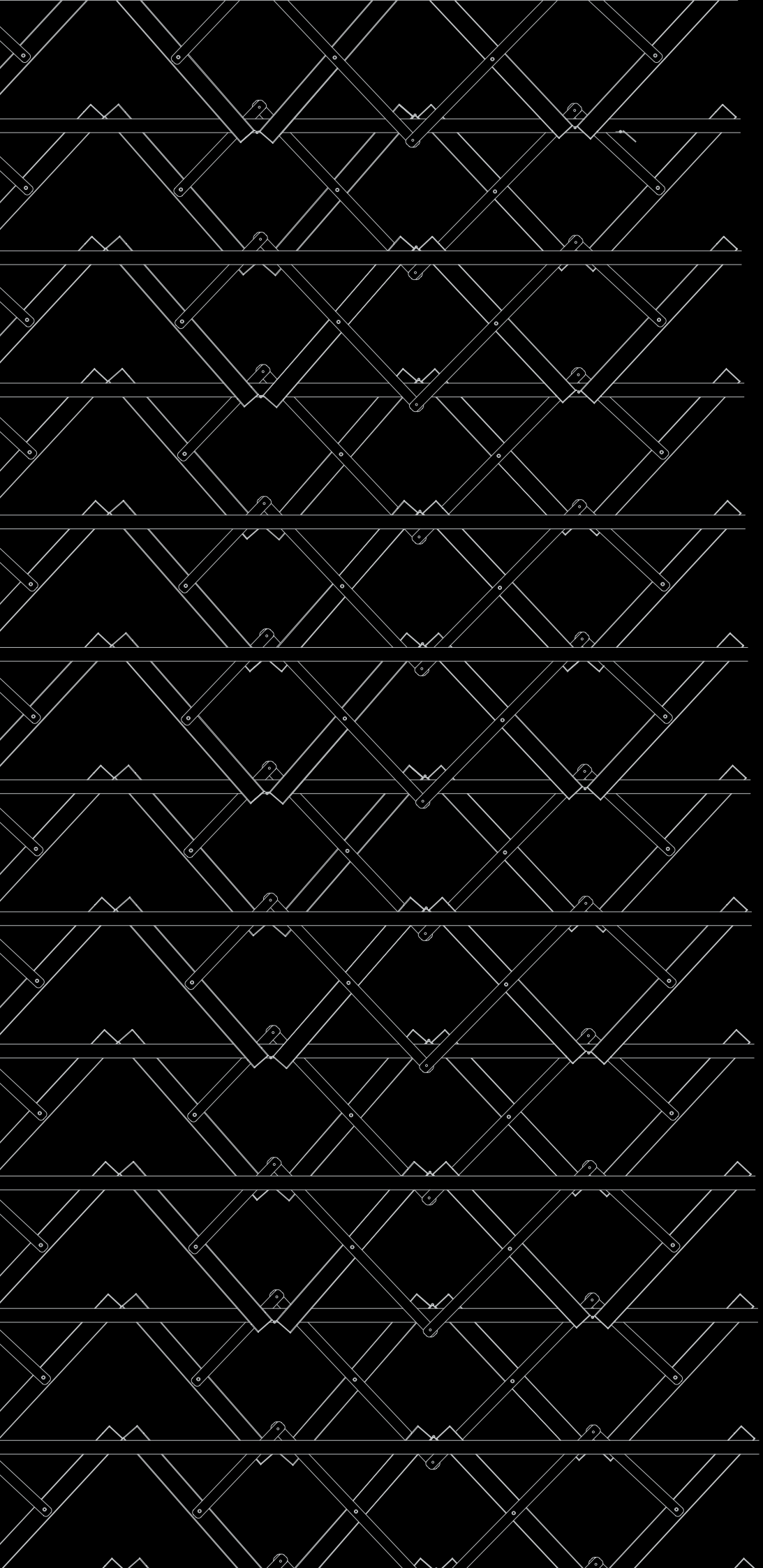

# FOLDING & SLIDING SHUTTERS

# FOLDING & SLIDING SHUTTERS





# FOLDING & SLIDING SHUTTERS

Solar Control



Hunter Douglas offers sliding shutters with an architectural aesthetic that provides solar control solutions that are durable, colorful and offer heat and light regulation. The new generation of Hunter Douglas Folding & Sliding Shutters offers an elegant, flexible and high-performance solution for exterior solar control. It is mainly designed for residential applications and also for office and commercial buildings.

The various alternatives of inlayers such as Metalbrise, Woodbrise, ScreenPanel and fabrics allow this solution to be customized to fit the aesthetic and functional requirements established by the architect. The extrusions that compose the aluminum framework and accessories are made according to high standards, ensuring perfect performance over time for both sliding and folding systems.

Hunter Douglas Sliding & Folding Shutters are the perfect way to improve a building's interior thermal and visual comfort, creating a striking and colorful exterior. The sliding aluminum framework can be in some cases hidden by the inlayer or fabric. This product is available in a wide range of colors, providing façades with a high quality vertical architectural appearance.



## STANDARD COMPONENTS

### UPPER RAIL

Material: aluminum

Finish: anodized or painted

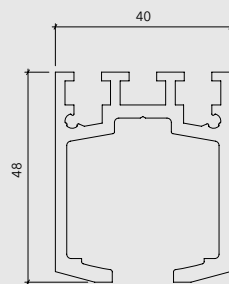

### HORIZONTAL PROFILE

Material: aluminum

Finish: anodized or painted

Maximum length: 3000 mm

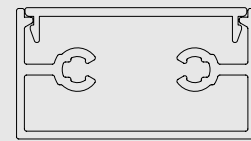

### LOWER T-TYPE RAIL

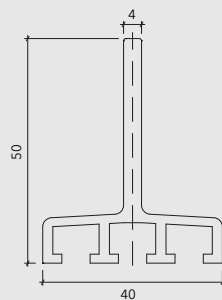

### HEAVY DUTY PROFILE (VERTICAL)

Material: aluminium

Finish: Anodized or painted

Maximum length: 5000 mm

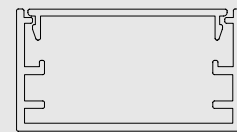

### LOWER U-TYPE RAIL

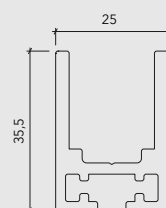

## SLIDING SHUTTER INSTALLATION

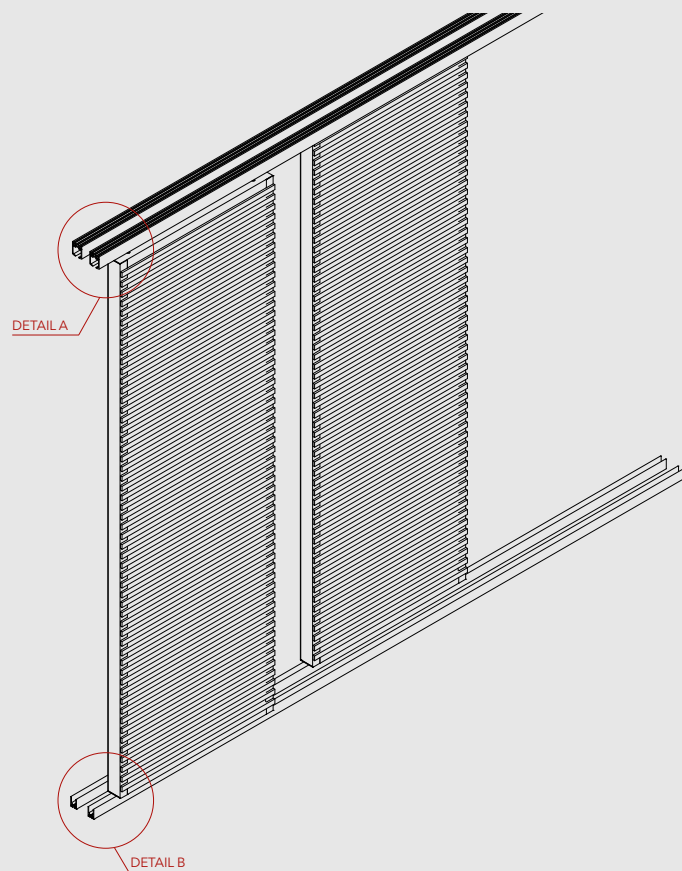

### DETAIL A

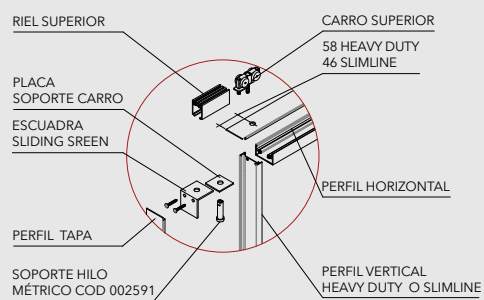

### DETAIL B

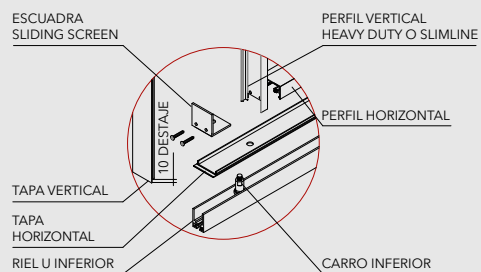

### SLIDING OPTIONS (FRONT VIEW)

#### 1 RAIL

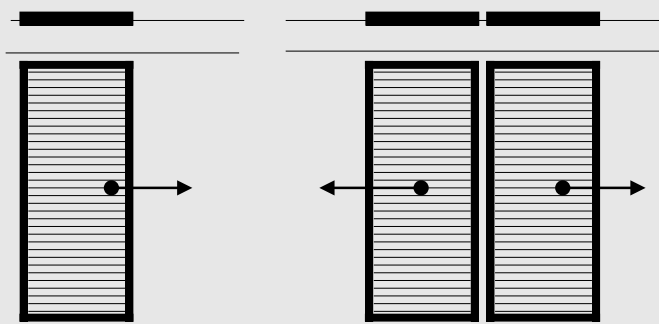

#### 2 RAILS

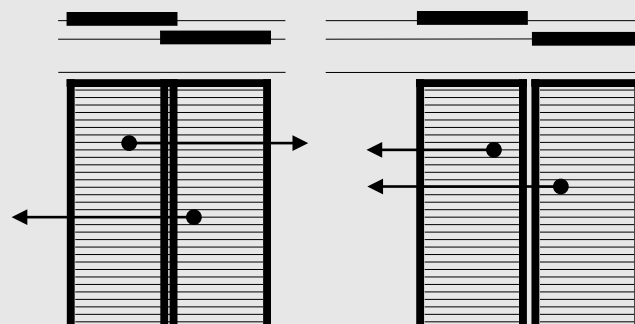

#### 3 RAILS

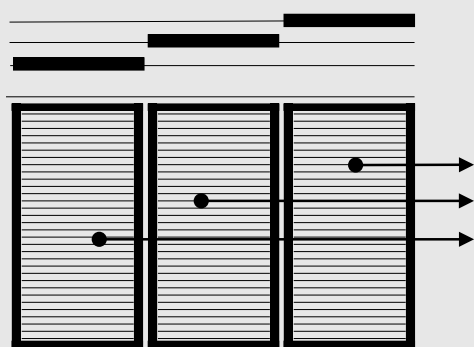

#### 4 RAILS

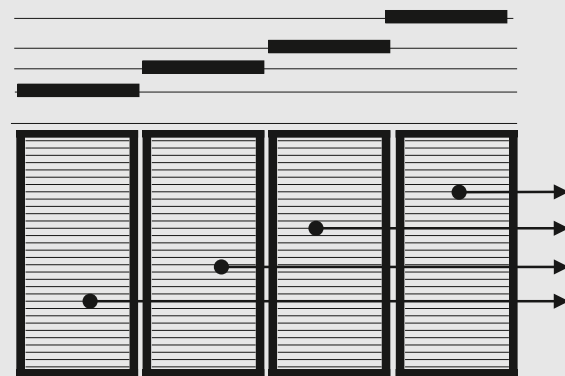

# FOLDING & SLIDING SHUTTERS

Solar Control





# FOLDING & SLIDING SHUTTERS

Solar Control

## INSTALLATION OF FOLDING & SLIDING SHUTTERS

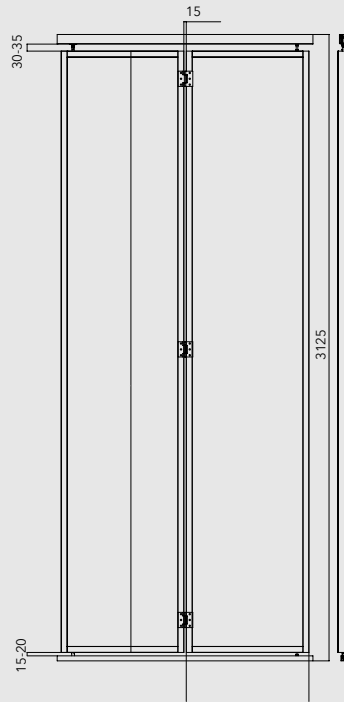
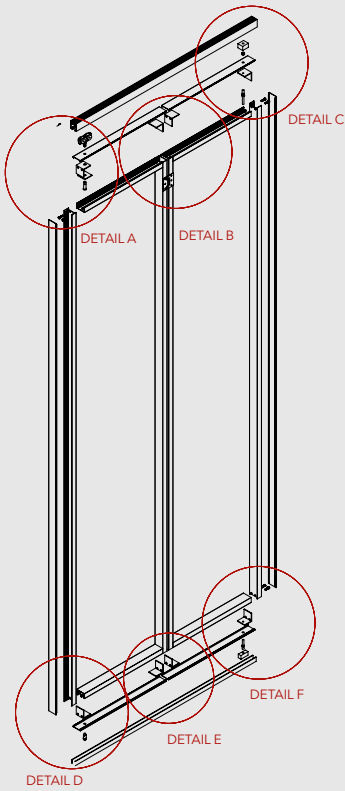

Note: The dimensions of the leaves should be evaluated for each project.

### DETAIL A

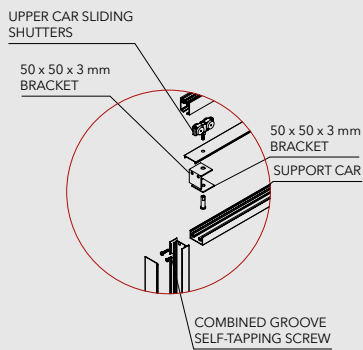

### DETAIL B

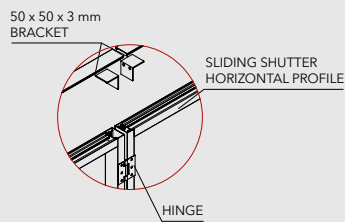

### DETAIL C

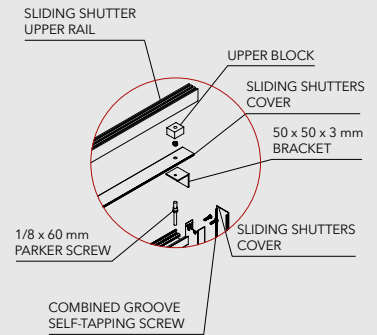

### DETAIL D

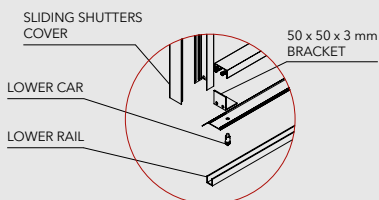

### DETAIL E

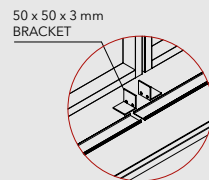

### DETAIL F

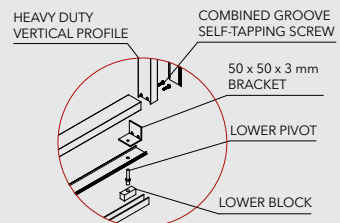



## 2 FRAME FOLDING SHUTTER - 2 SIDE FOLDING

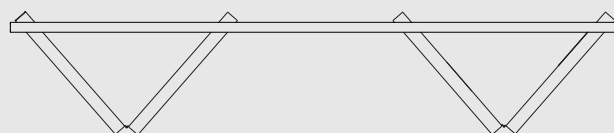
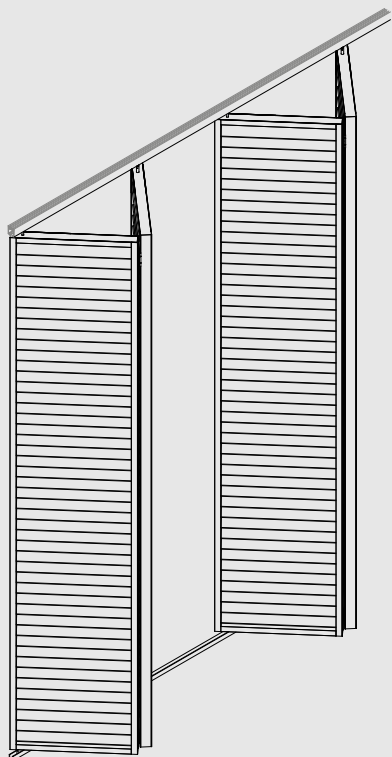

### 2 LEAF INSTALLATION OPTIONS

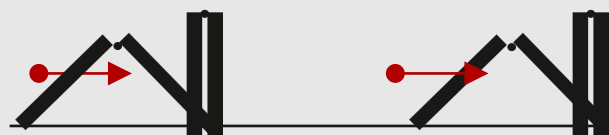
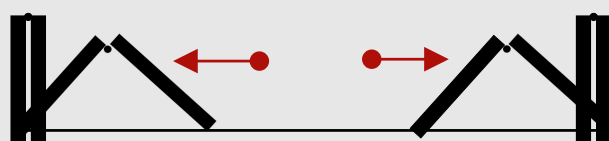

## 4 FRAME FOLDING SHUTTERS - ONE SIDE FOLDING (MAX. 6 FRAMES)

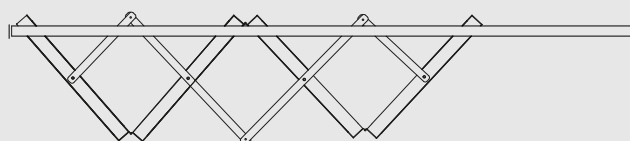
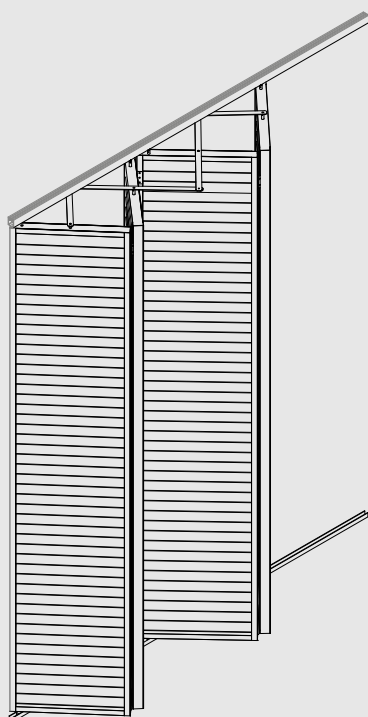

### 4 FRAME INSTALLATION

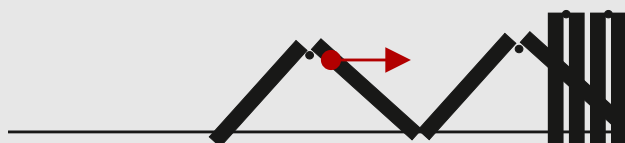

# FOLDING & SLIDING SHUTTERS

Solar Control

## INLAYER OPTIONS

### ALTERNATIVE MATERIALS

Apart from the standard slats, a wide range of materials can be used for Hunter Douglas Sliding shutters. Various inlayer options are provided below. Custom materials and solutions are available upon request.

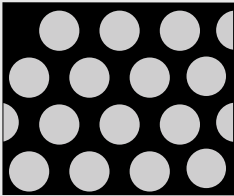

PERFORATED METAL

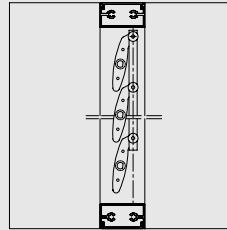

WOODBRISE 66

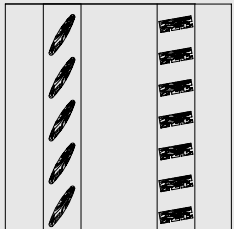

WOOD

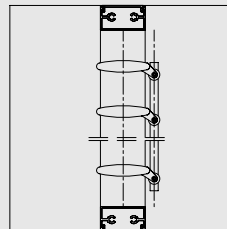

MOBILE METALBRISE

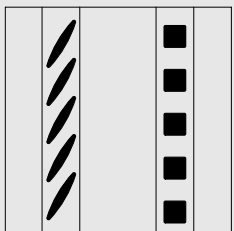

METAL

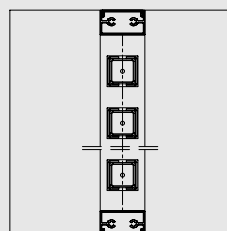

QUADROBRISE 32 X 32

### METALBRISE

### SCREENPANEL

### QUADROLINE 15 X 10

### QUADROBRISE 32 X 32

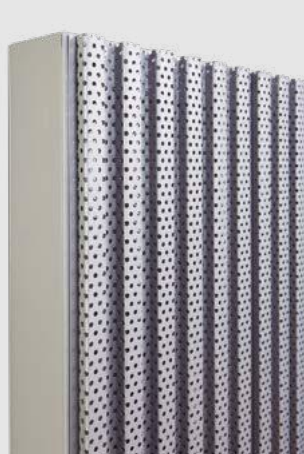

- Materials: aluminum, zinc-aluminum
- Colors: over 100 solid colors, woodgrains and mineralgrains
- Sun control: fixed or moveable angle

- Materials: aluminum, zinc-aluminum
- Finish: smooth and perforated
- Colors: based on Powder Coating array

- Materials: aluminum, zinc-aluminum
- Finish: smooth and perforated
- Colors: over 100 solid colors, woodgrains and mineralgrains
- Position: horizontal and vertical

- Materials: aluminum, zinc-aluminum
- Finish: smooth and perforated
- Colors: over 100 solid colors, woodgrains and mineralgrains
- Position: horizontal and vertical

UPPER DETAIL

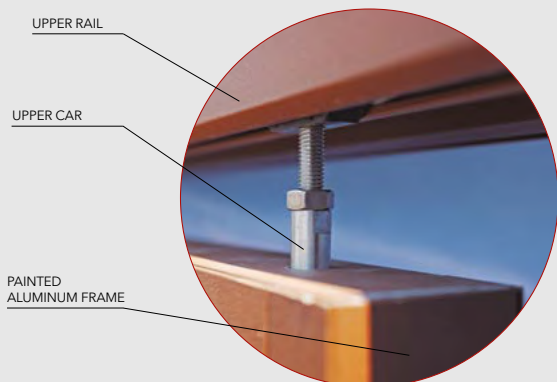

LOWER DETAIL

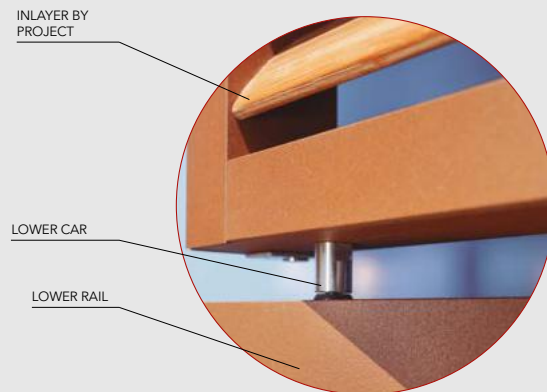

DETAIL A

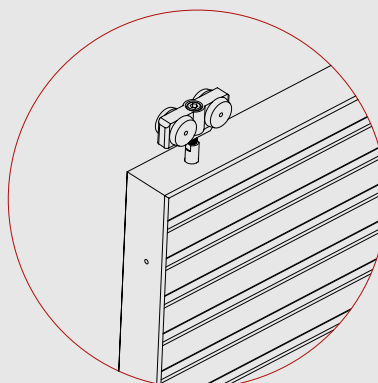

DETAIL B

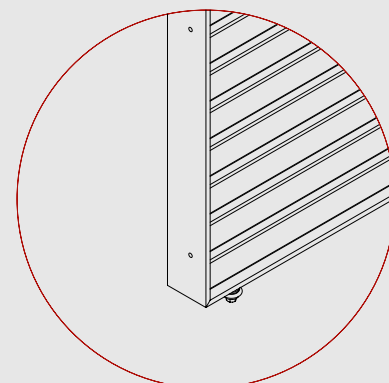

TRAPEZOIDAL WOODBRISE



- Materials: lenga, bamboo
- Finish: finished with stain or not colored depending on technical specifications
- Sun control: fixed angle or tilting

WOODBRISE 66 / 100



- Materials: lenga, cedar, bamboo
- Finish: finished with stain or not colored depending on technical specifications
- Sun control: fixed angle or tilting

RECTANGULAR 30 X 18 WOODBRISE



- Materials: lenga, bamboo
- Finish: finished with stain or not colored depending on technical specifications
- Position: horizontal and vertical

Note: The components of this product are constantly being improved and developed, so modifications may be made. The measurements listed on this Technical Sheet are expressed in millimeters (mm). In order to ensure that the product works correctly, the installation should always be handled by an authorized distributor using all of the accessories listed and in accordance with Hunter Douglas technical specifications.

# FOLDING & SLIDING SHUTTERS

Solar Control





# TEXSCREEN

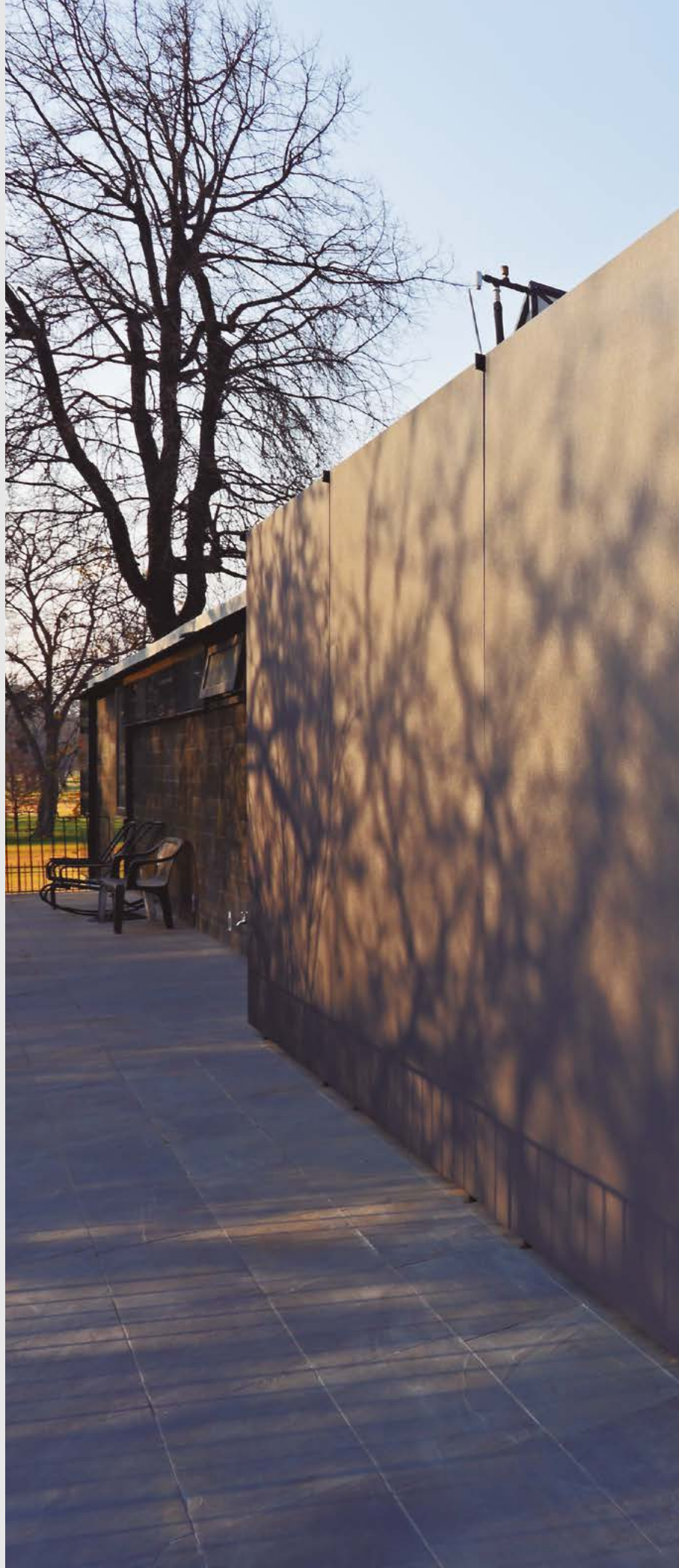





TexScreen is a product that allows an aluminum frame with exterior use fabric to be incorporated into the building's façade, providing a finish that is both attractive and clean. It is a light and homogeneous product that allows for the incorporation of new colors and textures. Given that it has been designed for exterior installations, it also provides excellent sun control and glare prevention.

### TECHNICAL DESCRIPTION

- Frame: aluminum painted using electrostatic technology
- Cloth: acrylic cloth (glass fiber + PVC), other options available
- Degrees of transparency: 3% and 30%
- Standard width: 1200 mm
- Standard height: 3500 mm
- Anchoring options: inside or outside openings
- Uses: the product is designed to be part of the façade of any structure, contributing:
  - Solar control from the various orientations towards the interior of the buildings, improving user comfort
  - Opportunities for design based on feasible lengths and widths
- Sun protection: In contrast to other materials, fabrics can generate clear views of the outside despite having a low percentage of transparency. This allows for solar gains to be decreased and provides very effective glare prevention without generating a sense of enclosure. Some of the tangible benefits are therefore:
  - Lower energy consumption for climate control
  - Higher quality natural light
  - Visibility of the exterior (depending on transparency levels)
  - Privacy for interior spaces during the day



### GLARE AND HEATING

Fabric prevents solar radiation from entering the building even if it hits the façade at a perpendicular angle. This makes it a superior solution for protecting east- and west- facing façades and skylights and, in practice, any other orientation.

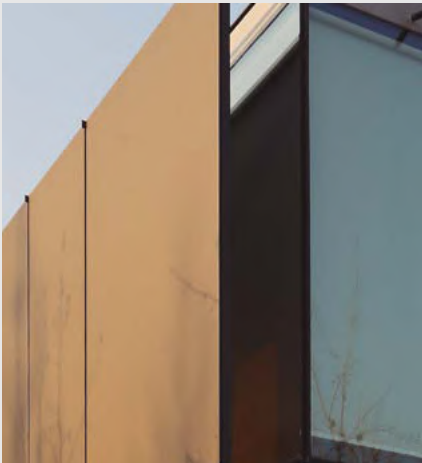

WITHOUT CURTAIN

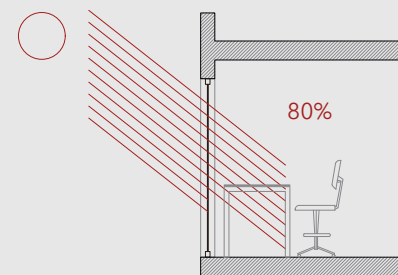

WITH CURTAIN INSIDE DEPENDING ON FABRIC TYPE

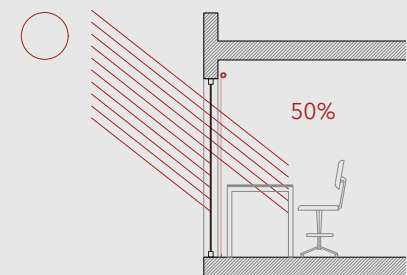

WITH CURTAIN ON OUTSIDE

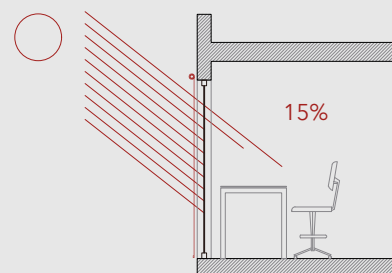

A sun protection product is more effective when it is placed on the outside. This is due to the fact that the fabric intercepts radiation before it enters the building.





## INSTALLATION

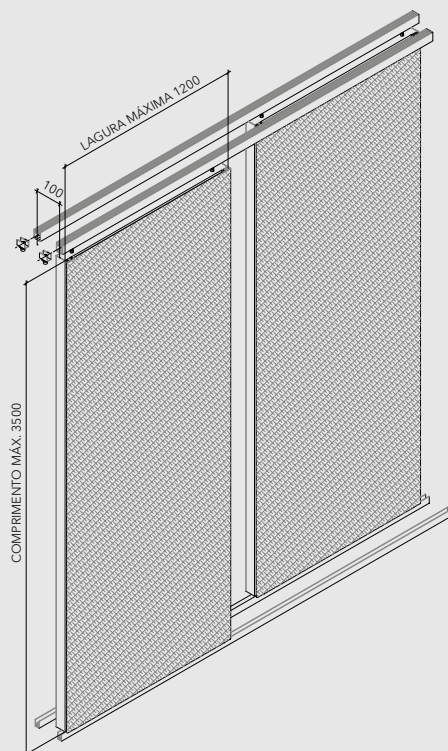

### CUTTING DESPIECE

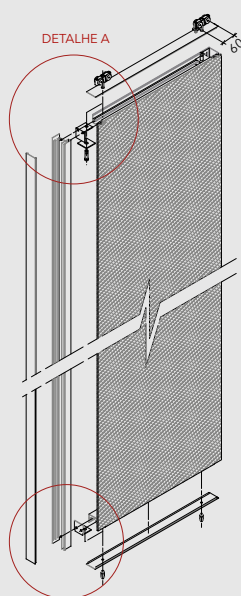

### DETAIL A DETALLE A

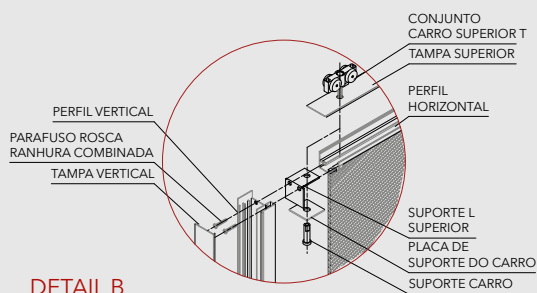

### DETAIL B

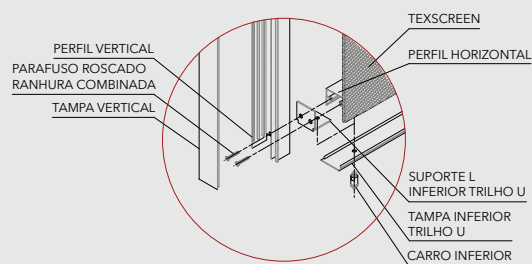

### TEXSCREEN FOLDING PANELS

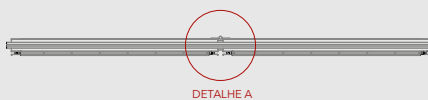
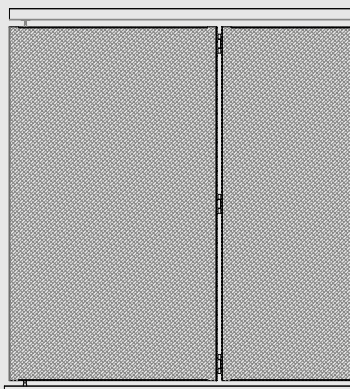

Note: For Folding & Sliding Shutters products, an engineering study must be conducted to identify formats and anchoring based on the project conditions. Maximum two leaves per system.

# TEXSCREEN

Solar Control | Folding & Sliding Shutters



## COLOR AND TRANSPARENCY OPTIONS

In order to ensure adequate use of a space, the interior must be protected from the direct effect of the sun.

TexScreen prevents interior glare without losing exterior views, thus better using the entire useful surface of the building. The photographs show an eastern view during the morning. The yellow colors show high levels of glare, which is clearly improved when a 12% opening fabric is installed.

The various opening percentages offered by Hunter Douglas generate different levels of sun control and exterior views.

### GRAPHIC SCALE

High risk of glare



Low risk of glare



REAL PHOTOGRAPH WITH TEXSCREEN



WITHOUT TEXSCREEN

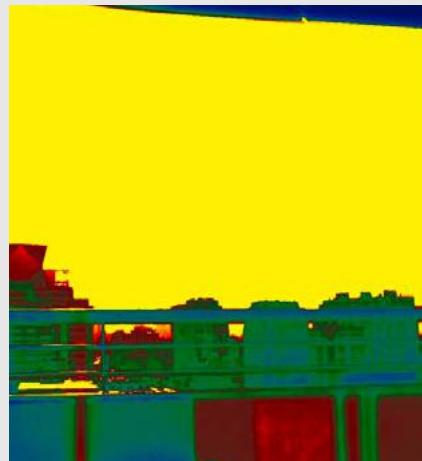

WITH TEXSCREEN

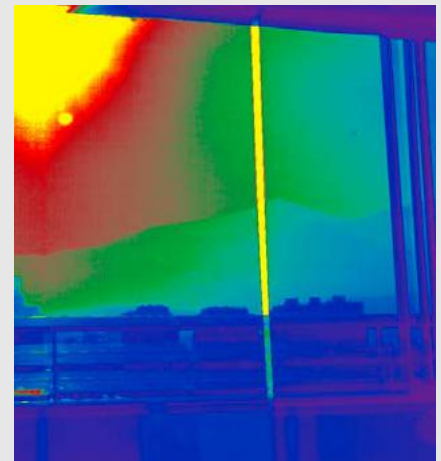

## MODULE FRAME- FABRIC AND OPENING SYSTEMS

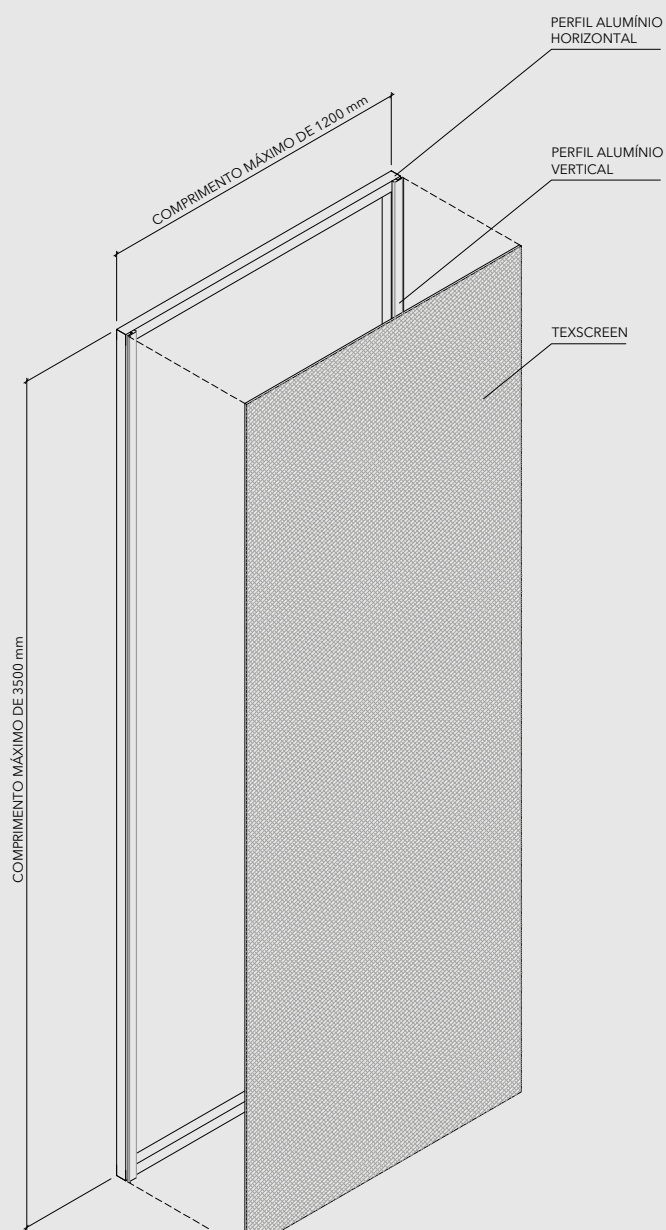

SLIDING

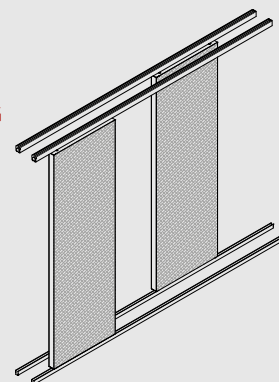

FOLDING

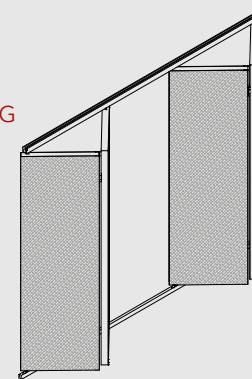

FIXED

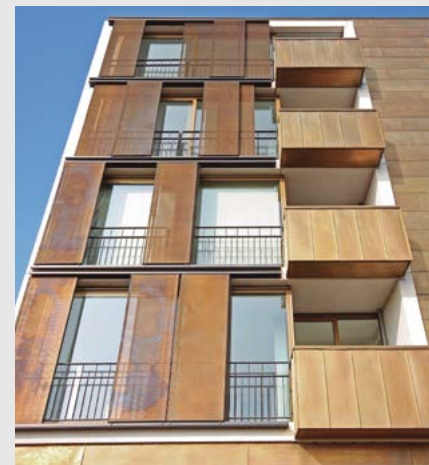
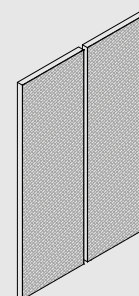

## COLOR AND TRANSPARENCY OPTIONS

---



12% Natte Charcoal/Charcoal Fabric



12% Natte Bronze/Gray Fabric



5% Satine Bronze/Sable Fabric

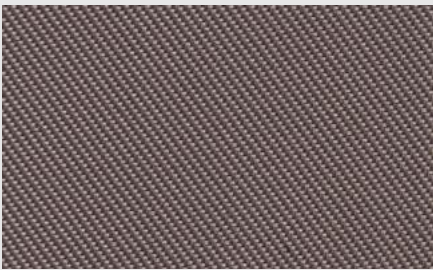

5% Satine Charcoal/Grey Fabric



In general, darker fabrics generate better visibility of the exterior while lighter fabrics increase the performance of lights and will better distribute the light inside of the building.

## ALUMINUM FRAME COLOR OPTIONS

---

Hunter Douglas offers a variety of finish colors for aluminum frames in order to obtain the most adequate finish for each project.



Red



Winter White

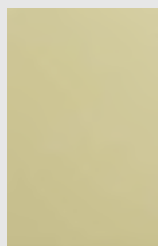

Sand

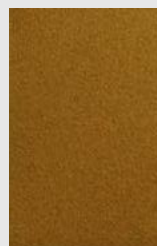

Corten

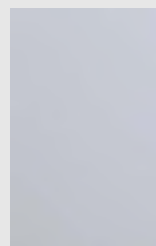

RAL Grey

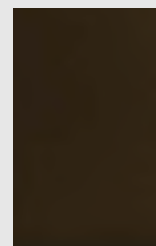

Brown

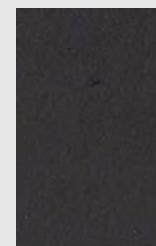

Anthracite

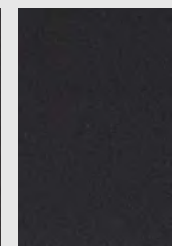

Black

## FIXED FRAME ANCHOR SYSTEM

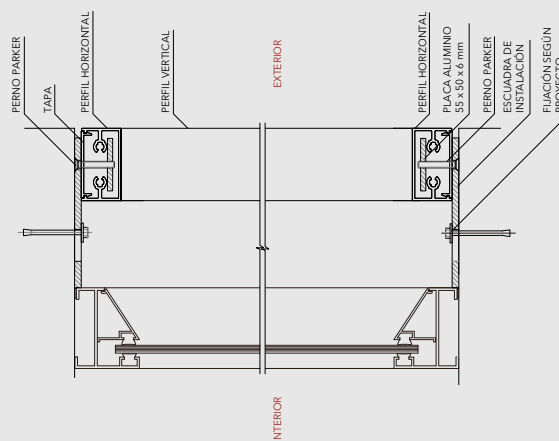
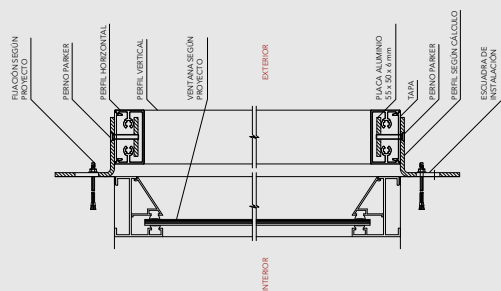

For correct installation using a fixed frame, we recommend considering a technical corridor that is at least 60 cm wide in order to be able to clean the windows from the outside (in the case of fixed frame installations and tall buildings).

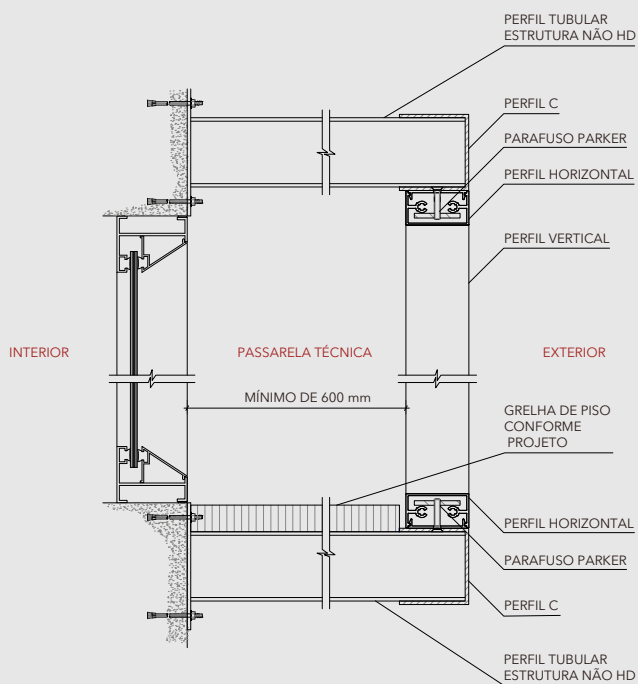

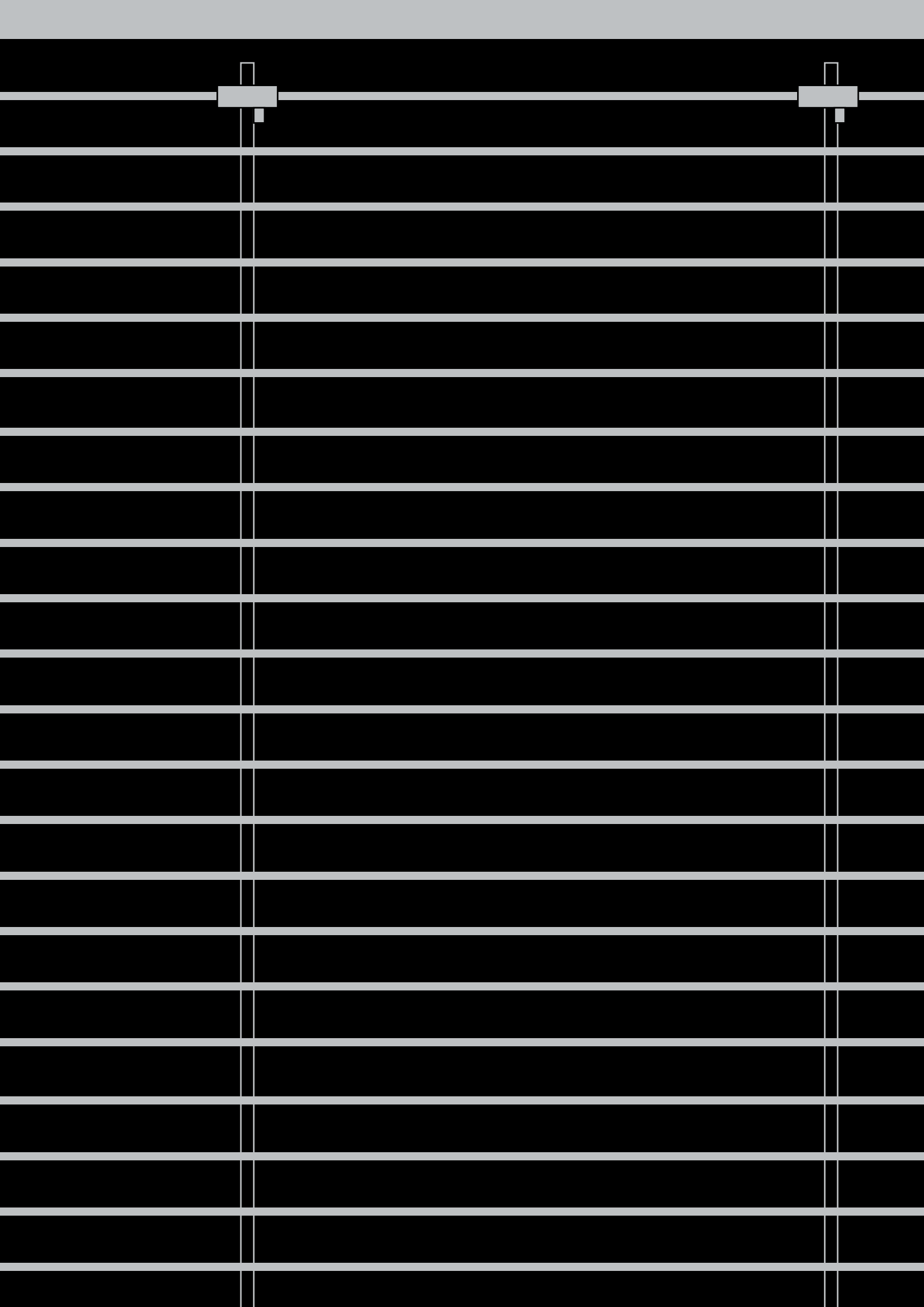

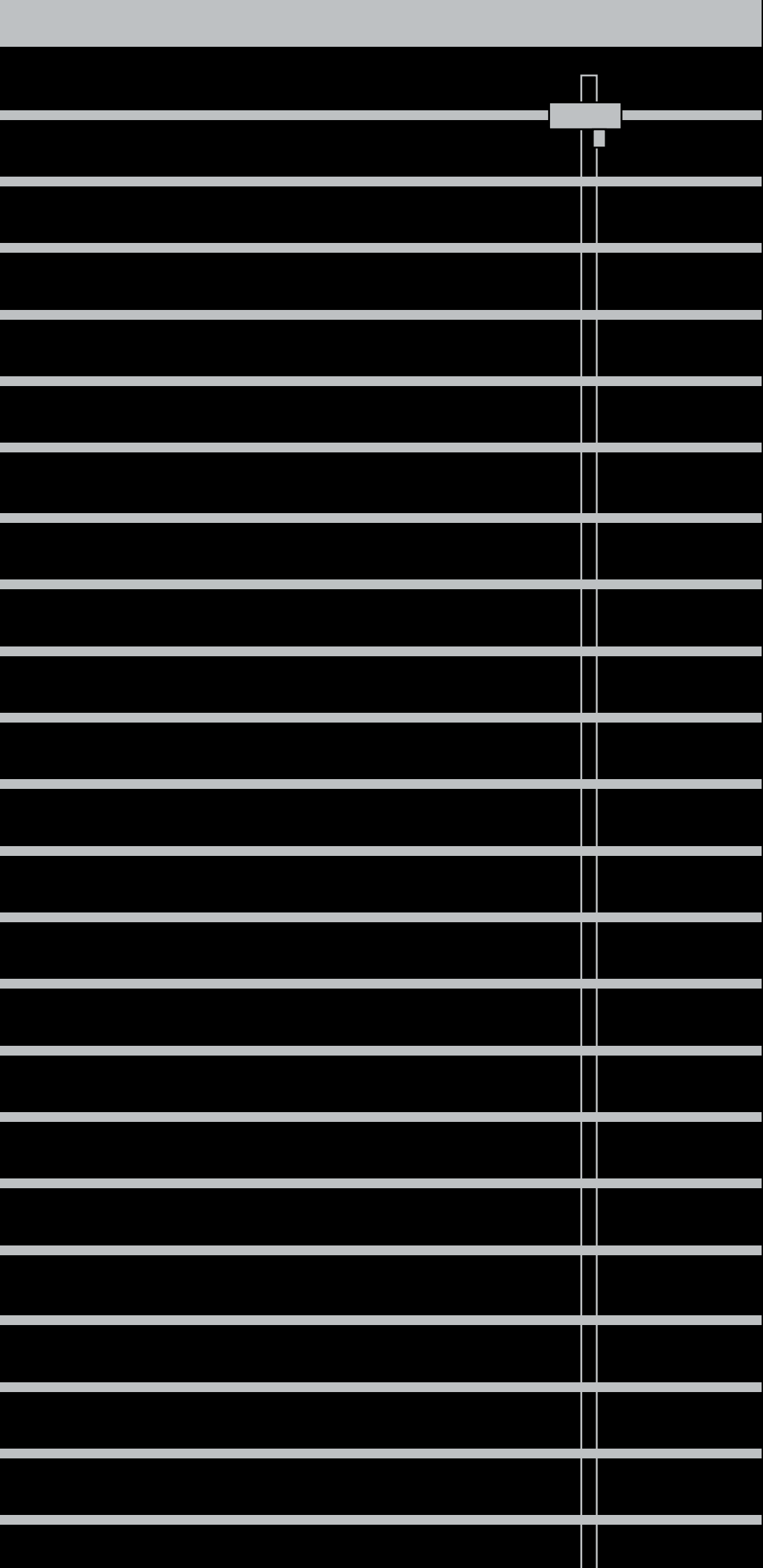

**ROLLER SHADES, BLINDS AND AWNINGS**

# 80 MM OUTSIDE ALUMINUM BLINDS







# 80 MM OUTSIDE ALUMINUM BLINDS

Solar Control



Architects have used Hunter Douglas 80 mm Aluminum Exterior Blinds for years because they have been proven to provide the most efficient and flexible light and sun control.

Their main attribute is their minimal heat transfer to the interior, which gives them the lowest Shadow Factor in window treatments and also controls the diffusion of light and shine.

From the user perspective, they offer complete flexibility and can be raised and lowered depending on the weather conditions and needs of each space. Their rotation angle can be regulated to allow for or avoid direct natural light as needed.



## CHARACTERISTICS

**ENTRY OF LIGHT:** Protection against solar heat inevitably implies blocking light from entering a space. However, Hunter Douglas 80 mm Aluminum Exterior Blinds can be adjusted to adapt the level of light that enters a room to the needs of each user and space.

**DISTRIBUTION OF LIGHT:** By adjusting the angle of the 80 mm Aluminum Exterior Blinds, users can reduce the high level of intensity of the light that enters through the window, improving luminosity in the darkest parts of the room.

**SUN CONTROL:** 80 mm Aluminum Exterior Blinds provide an effective sun protection. The shades open at a 40 degree angle without considering the glass, allowing 10% solar radiation inside. This provides pleasant work conditions and significantly decreases the need for air conditioning.

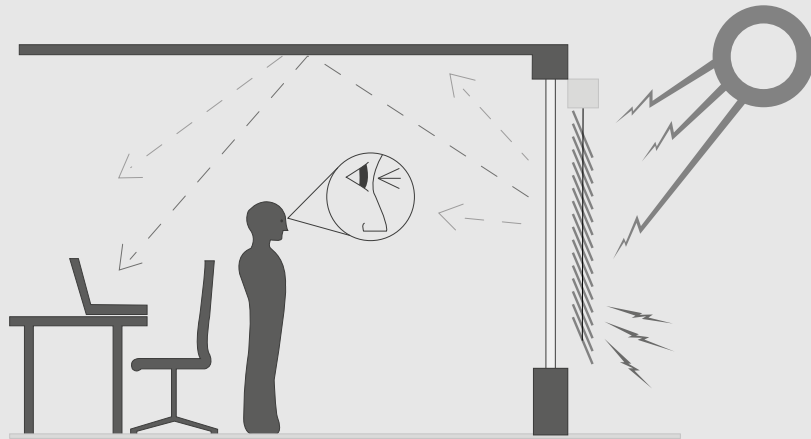

REDUCTION OF REFLECTION ON PC MONITORS	DISTRIBUTION OF LIGHT	ENTRY OF LIGHT
Reduction of eye fatigue and poor performance through the reduction of reflections	Adjusting the angle of the shades allows the reflection of the light to be focused on the upper part of the room	Precise adjustment, which satisfies the needs of each user.

## ACTION

80 mm Aluminum Exterior Blinds are always motorized and can be operated individually or together to completely cover floors and façades. Their motor has thermal protection against overheating, so they are designed to be used for a short period of time. When that time is exceeded, the motor heats up and deactivates as a security measure. However, after a short pause, it can be used again.

Switch action: The switch is used to adjust the direction of the shades and to raise and lower the 80 mm Aluminum Exterior Blinds.



## COMPONENTS

**SLATS:** The slats are manufactured with a special 0,44 mm- thick aluminum allow and covered with polyester paint and hot enameled.

**HEADRAIL:** 57 x 51 mm canal made from aluminum profiles covered in polyester paint and hot enameled.

**ROTATION AND RAISING/LOWERING MECHANISM:** Made of durable, maintenance-free plastic. The positive rotation mechanisms prevents the movement of the shutters due to the wind. The rotation spring is made of stainless steel and enclosed in two different shutter suspension rings in order to ensure smooth, precise operation.

The shutter lowers with the slats completely closed and raises with them completely open.

**RISING TAPE:** Made of preshrunk polyester (6 x 0,33 mm) that is weather and UV resistant.

**BOTTOM RAIL:** Extruded and painted aluminum profile that is adjusted to the form of the slats with plastic end caps provided with guide bolts or guide cable rivets.

**SLAT SUSPENSION:** Braided woven polyester ladder with 70 mm corridor that is UV and weather-resistant.

**CONNECTION CORD:** Woven, weather and UV-resistant polyester cord that links the ladder to the mechanism, allowing the release had rapid adjustment of the raised slats.

# 80 MM OUTSIDE ALUMINUM BLINDS

Solar Control

## OPERATION

Electric operation: with a 220 V 50 Hz or 110V 60Hz motor (depending on the voltage required for the country) inside of the head. The motor has thermal protection against overheating and IP54 level protection against water and solid elements. The blinds also can be operated using a remote control. A radiofrequency signal receiver should be added for each motor in this case.

It is possible to control groups of blinds that can completely cover floors and façades using control elements such as sensors, timers or automated control systems.

Note: The components of this product are constantly being improved and developed, so modifications may be made. The measurements listed on this Technical Sheet are expressed in millimeters (mm).

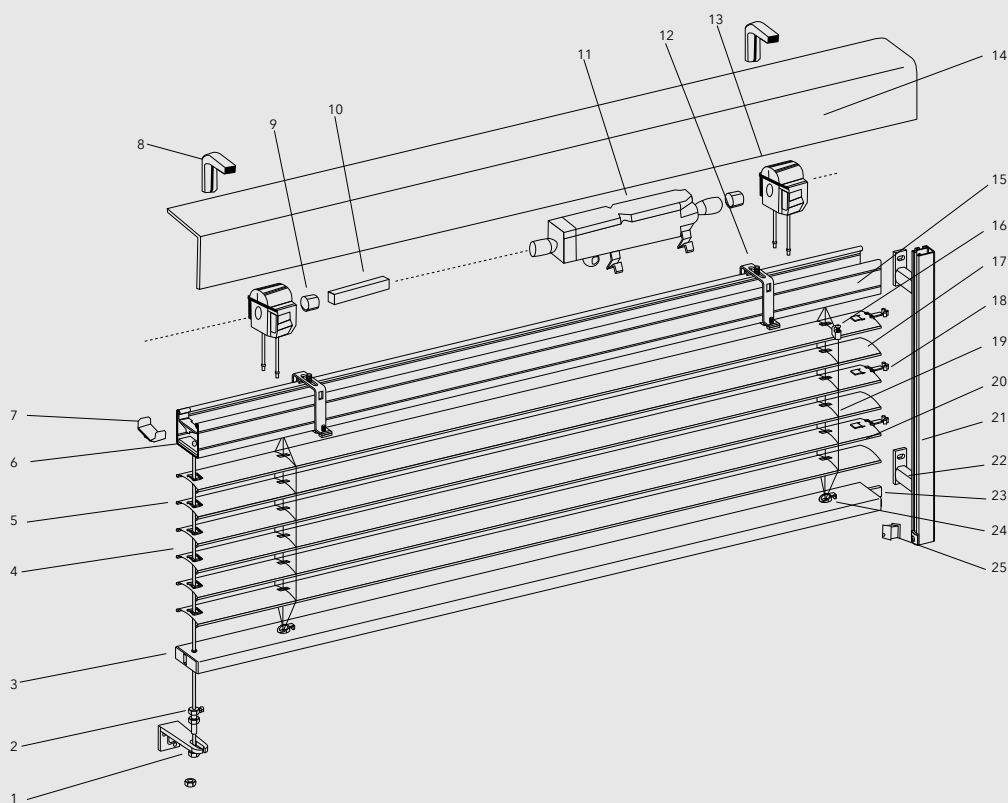

DESCRIPTION AND CUTTING CODES					
1	Support for cable guide	COAESOP007	15	HDE Wooden head	PEMACAB002
2	Tensor for cable guide	COAETEN001	16	80 mm ladder connector	COAECON001
3	Base profile for 80 mm PEA	PEAPER004	17	80 mm slat	LAAELAM001
4	Guide cable for 80 mm PEA	COAECAB001	18	Horizontal brake pin for 80 mm PEA	COAEPIN001
5	Plastic protector for 80 mm slat	COAEPRO001	19	Ladder for 80 mm PEA	COAEESC001
6	Deck for guide cable	COAEPL001	20	Ribbon/cord for 80 mm PEA	COAECIN001
7	50 HDE head safety	COAESEG001	21	Lateral profile for 80 mm PEA	PEAPER002
8	100 x 100 wall/roof support	COAESOP009	22	70-105 lateral profile bracket for 80 mm PEA	COAESOP005
9	12 mm square axis attachment ring	COAEANI001	23	Lateral profile slat guide pin	COAEGUI001
10	12 mm aluminum guide share axis	PEAEJE001	24	Ladder cover	COAETAP003
11	D2495 220v/50 Hz motor for 80 mm PEA	MOAEMOT002	25	Lateral profile run end pin for PEA	COAEPIN003
12	Installation bracket for 80 mm pea	COAESOP001			
13	Drum bracket for 80 mm PEA	COAESOP003			
14	Valance				

SYSTEM TYPES							
TYPE	SLAT WIDTH (mm)	OPERATION TYPE	LATERAL GUIDE	MIN. WIDTH (mm)	MAX. WIDTH (mm)	MIN. HEIGHT (mm)	MAX. SURFACE AREA (m <sup>2</sup> )
EL80A	80	MOTOR	CABLE	800	5000	4500	12
EL80AS	80	MOTOR	STANDARD LATERAL PROFILE	800	4000	4000	12
EL80ASK	80	MOTOR	LATERAL PROFILE WITH FASTENING	800	4000	4000	12

NAME	COLOR CODE	SUN (300-2500 Nm)		VISIBLE LIGHT (380 - 780 Nm)	
		TOTAL VALUE REFLECTION	TOTAL VALUE ABSORPTION	TOTAL VALUE REFLECTION	TOTAL VALUE ABSORPTION
GRAPHITE	L80843	0,1540	0,8460	0,1540	0,8460
WORN COPPER	L80841	0,2354	0,7646	0,2309	0,7691
SILVER	L80842	0,4857	0,5143	0,4882	0,5118
WHITE	L80840	0,7553	0,2447	0,7553	0,1775
CHESTNUT	L80844	0,1540	0,8460	0,1540	0,8460
RAULÍ	L80845	0,4857	0,5143	0,4882	0,5118

### INCLUDED IN THE SYSTEM

Exterior aluminum shutters with robust shaped slats measuring 80 mm with rounded edges. The components for the rotation, raising and lowering system are incorporated into the head.

SHUTTER HEIGHT INCLUDING SUPPORT AND HEAD	SPACE OCCUPIED	VALANCE HEIGHT (mm)
1000	162	223
1500	192	
2000	222	
2500	252	283
3000	282	
3500	312	373
4000	341	
4500	372	

### AVAILABLE COLORS



White

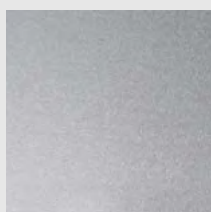

Silver

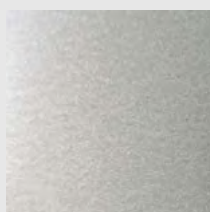

Worn Copper

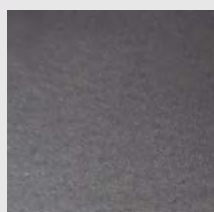

Graphite

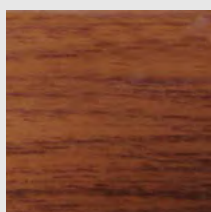

Raulí

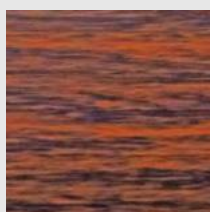

Chestnut

# 80 MM OUTSIDE ALUMINUM BLINDS

Solar Control

## MODELS:

- (A) Stainless steel cable guide
- (AS) Standard channel guide profile
- (ASK) Guide profile mounted on bracket supports

MODEL A

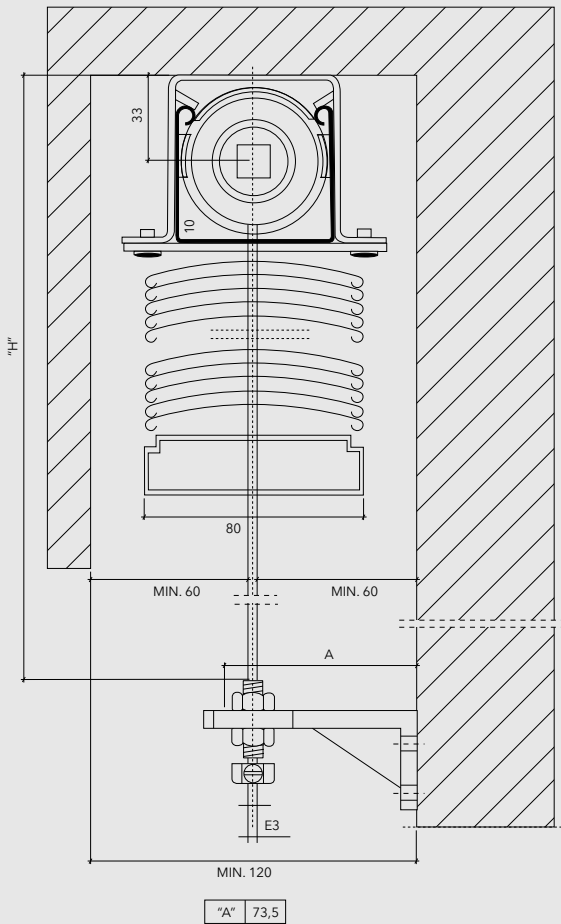

MODELS AS AND ASK

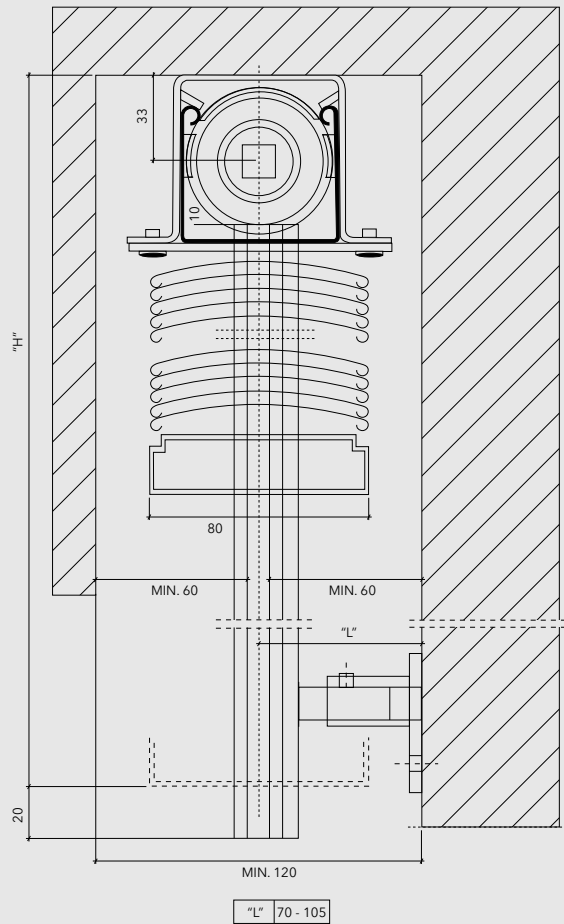

## MODEL A: CABLE GUIDE

Use in installations outside and inside opening

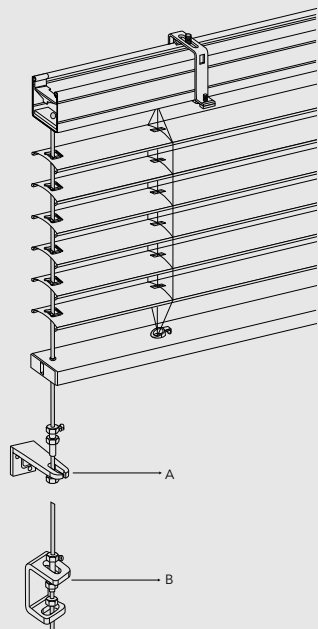

A. BRACKET FOR GUIDE CABLE

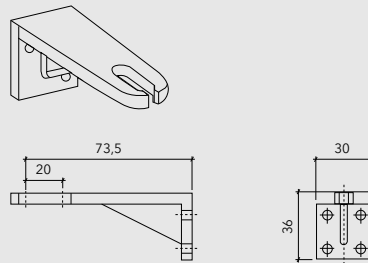

B. BRACKET FOR GUIDE CABLE

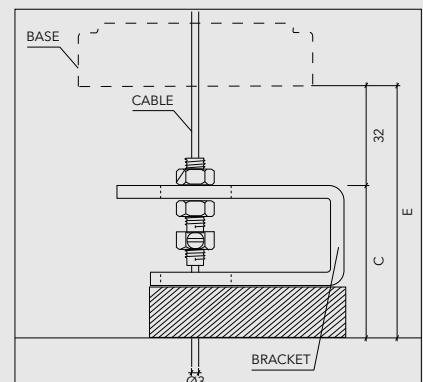
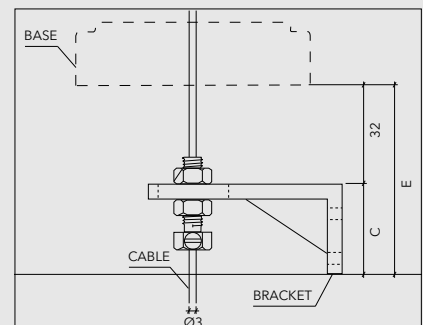
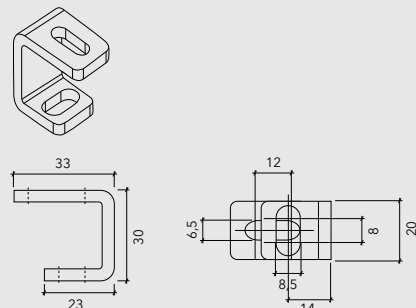

**AS MODEL: STANDARD LATERAL PROFILE GUIDE**  
 Use in installations outside and inside of bay

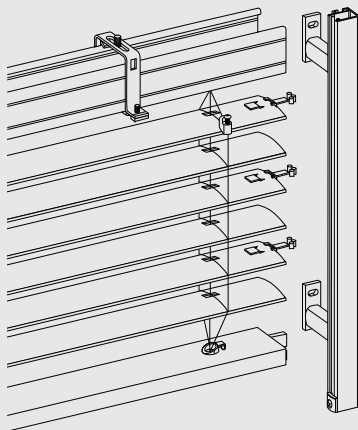

**INSTALLATION LATERAL PROFILE INSIDE OF BAY**

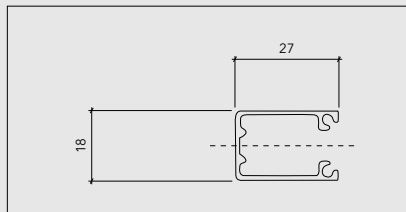

**INSTALLATION OF CENTRAL OR CONNECTION PROFILE OUTSIDE OF BAY**

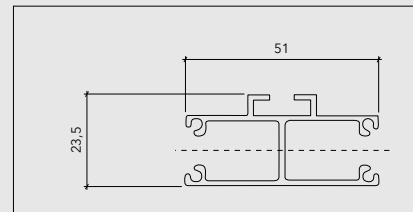

**INSTALLATION LATERAL PROFILE OUTSIDE OF BAY**

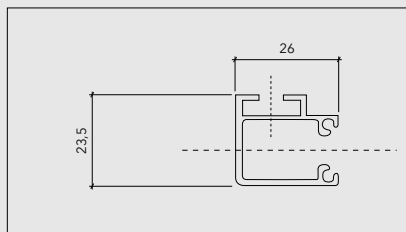

**AS GUIDE PROFILE BRACKET**

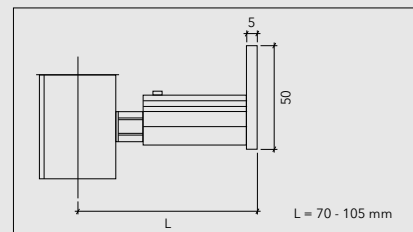

**ASK MODEL: ASSEMBLY ON LATERAL PROFILE GUIDE**  
 Use in installations outside of bay

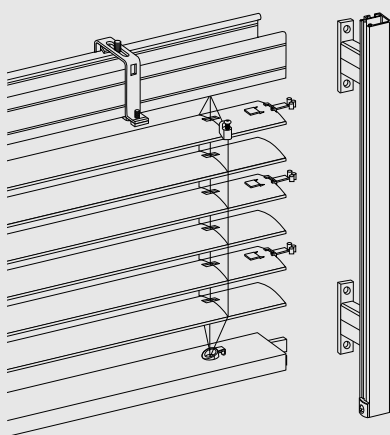

**LATERAL PROFILE**

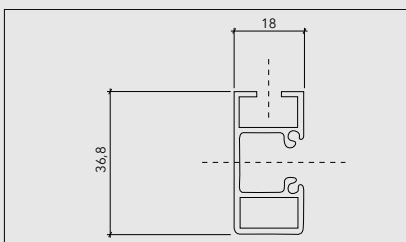

**CENTRAL OR CONNECTION PROFILE**

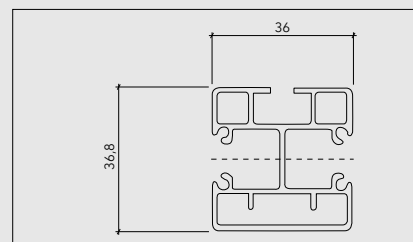

**HEAD SUPPORT TO BE MOUNTED ON LATERAL PROFILE**

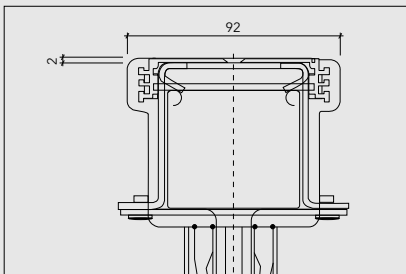

**ASK GUIDE PROFILE BRACKET**

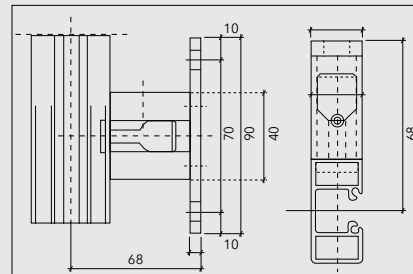

**DETAIL OF SELF-BRACKET**

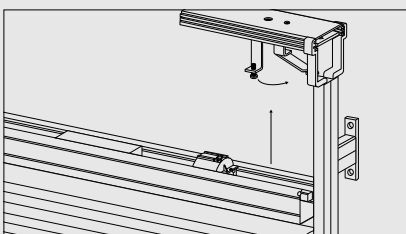

# 80 MM OUTSIDE ALUMINUM BLINDS

Solar Control



OPTIONAL

## FULL VALANCE

The height of the valance allows the cloth to be hidden when the shutter is completely raised.

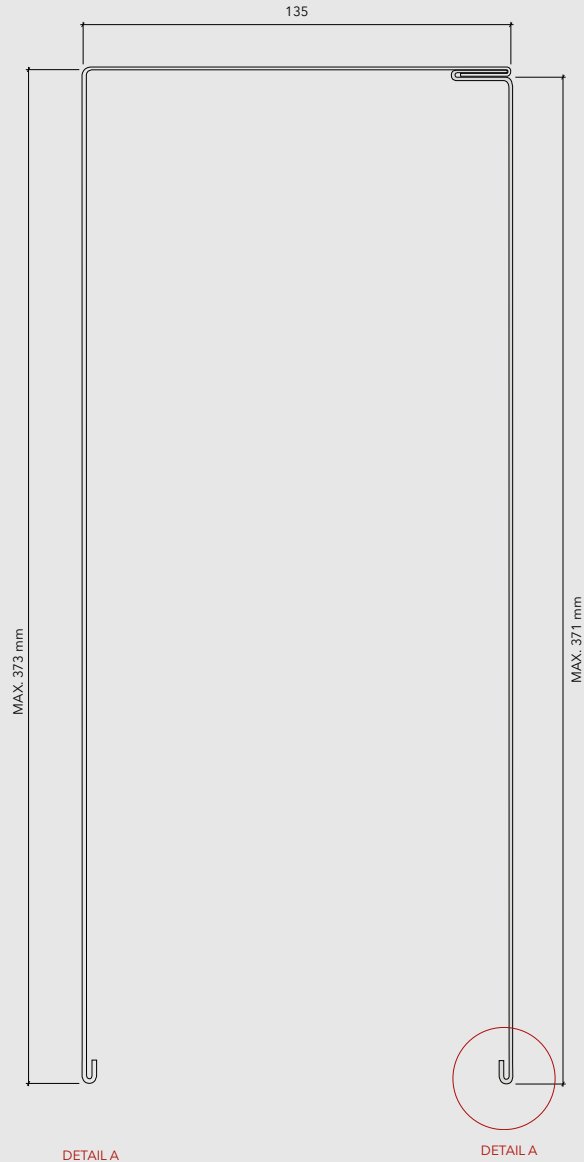

DETAIL A

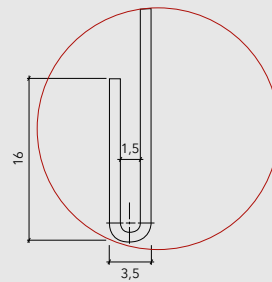

## COMPLETE VALANCE ASSEMBLY

STEP 1

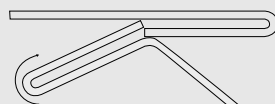

STEP 2

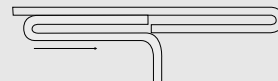

STEP 3

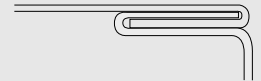





# VERTICAL AWNINGS





# VERTICAL AWNINGS

Solar Control



Hunter Douglas vertical awnings are specially designed for the outdoors. They are weather-resistant in all conditions. They also can be used to filter out UV rays before they reach the interior and enclose exterior spaces. We recommend that these products be installed in spaces in which there is a need for significant solar protection, windows without terraces and/or building terraces located between floors.

Our vertical awnings are easy to operate, allowing users to control sunlight while maintaining visibility and providing pleasant temperature conditions. They are activated using a guide cable, which means that they can be fastened in any position.

## CHARACTERISTICS

Our company offers two types of vertical awnings: Droppy Cabrio and Droppy Cofre.

**Droppy Cabrio:** Vertical awning in which the fabric rolled into the tube remains visible. The base profile is led by lateral cable guides along the fabric, which provides functionality in a safe manner.

**Droppy Cofre:** Vertical awning in which the fabric is protected by a compartment. Its base profile is led by lateral cable guides all along the fabric, which provides functionality in a safe manner.



### DROPPY CABRIO



### DROPPY COFRE

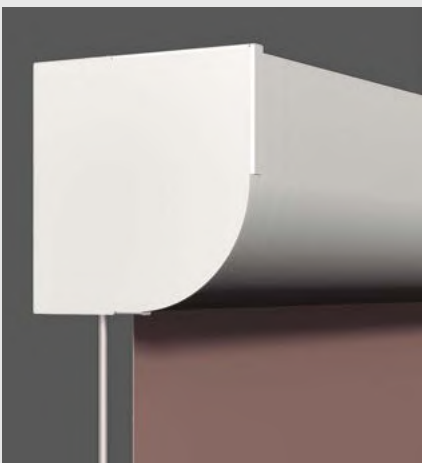

## INSTALLATION

### OPERATION

In order to determine how the awning will be operated, determine the side (right or left) on which the awning action will be installed and whether it will be manual or motorized considering its appearance from the inside of the room.

Manual operation: Awnings are operated using a crank (lengths: 1200, 1800 or 3000 mm) (Fig. 1) that activates a reducing gearbox (Fig. 2) located on either of the awnings ends, which allows it to be opened and closed, transmitting the pivot to the winding shaft of the fabric.

FIGURE 1

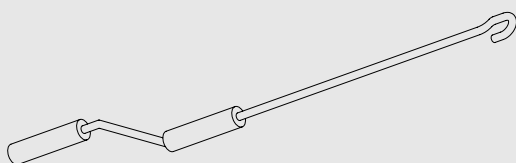
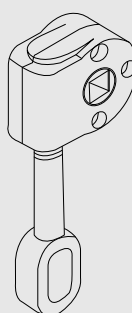

FIGURE 2



### MOTORIZATION

The crank and the reducing gearbox can be replaced by a tubular motor located inside of the winding shaft of the fabric.

### OPTIONAL\*

In order to ensure the optimal operation, comfort and sophistication of Vertical Awnings, the following automated features can be used with motorized operation:

**Light sensor:** The light sensor allows the awning to be set at the ideal height, automatically moving it as there is more or less light during the course of the day. When the intensity of the sun's rays is higher or lower than the amount programmed into the awning, the sensor detects this and opens or closes the awning automatically.

**Wind sensor:** This mechanism helps decrease the risk of damage due to winds exceeding 50 km/h. When the wind subjects the awning to oscillations and movements that could be dangerous, the wind sensor identifies this and closes the awning in order to protect it.

\*These options are available for both vertical awnings when they are motorized.

### DIMENSIONS

The maximum dimensions for each awning are determined by the type of fabric used. A table with specifications is provided on the next page.

# VERTICAL AWNINGS

Solar Control

## INSTALLATION

Maximum measurements for the Droppy Cabrio and Droppy Cofre Vertical Awnings specifications in screen and acrylic fabrics based on the type of action:

### FABRIC SCREEN

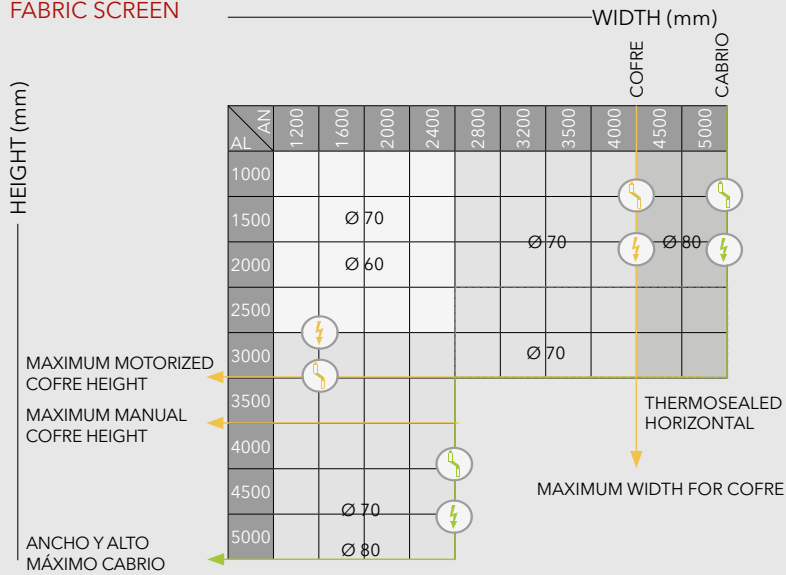

### SYMBOLS

- Crank action
- Motorized action
- Tube diameter
- Specifications for Droppy Cabrio vertical awning
- Specifications for Droppy Cofre vertical awning

### ACRYLIC FABRICS

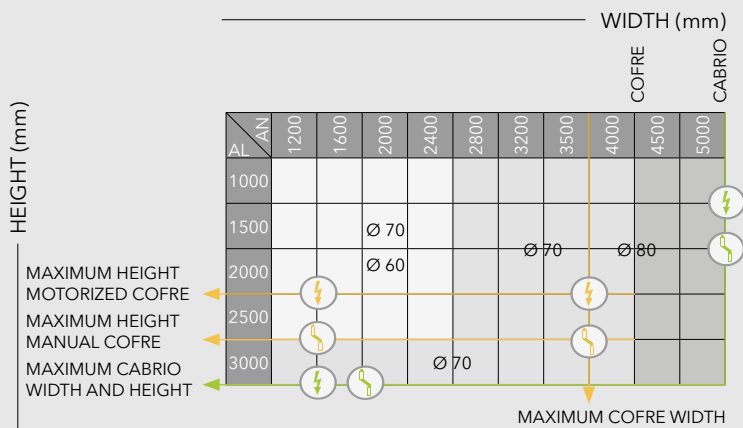

It is important to consider the dimensions necessary for installation in order to configure the selected awning.

## INSTALLATION DIMENSIONS

### WALL INSTALLATION

#### Rear View Cut A-A

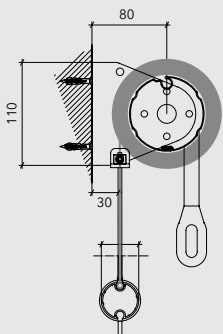

#### Rear View

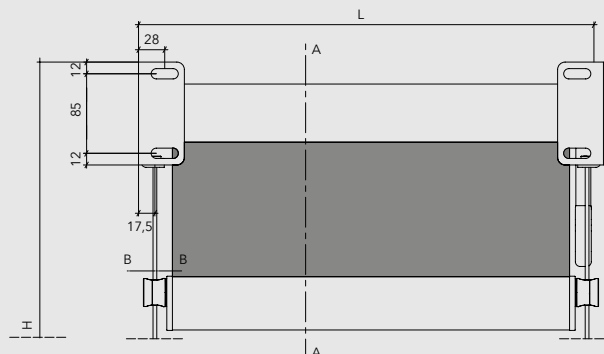

## ROOF INSTALLATION

## REAR VIEW CUT A-A

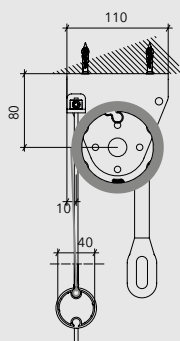

## REAR VIEW

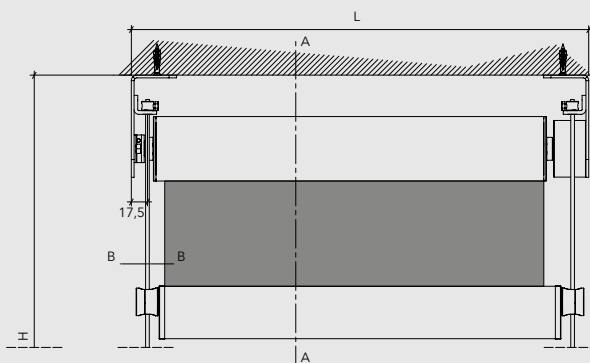

## LOWER BRACKET INSTALLATION

## WALL BRACKET

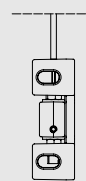
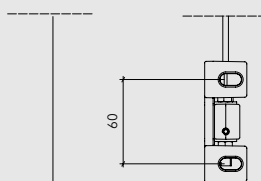
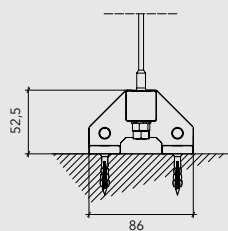

## FLOOR BRACKET

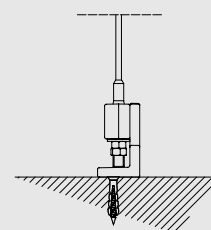
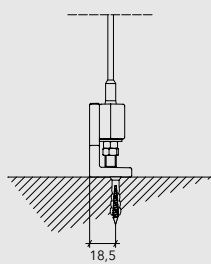
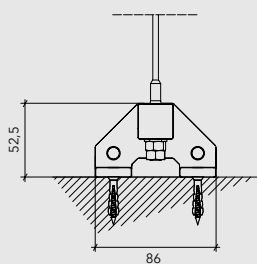

## UPPER VIEW



Note: The components of this product are constantly being improved and developed, so modifications may be made. The measurements listed on this Technical Sheet are expressed in millimeters (mm). In order to ensure that the product works correctly, the installation should always be handled by an authorized distributor using all of the accessories listed and in accordance with Hunter Douglas technical specifications.

# PRECIOUS METALS ALUMINUM BLINDS







# PRECIOUS METALS ALUMINUM BLINDS

Solar Control



Precious Metals Aluminum Blinds provide exclusive decorative solutions with residential and institutional options for every window size.

The Classic 16 mm and 25 mm, Horizontal 50 mm and Premium 25 mm lines offer absolute privacy, perfect visual comfort and protection against UV rays.

The 16 mm and 25 mm Classic line has an Ultimate Pro head and base. This hardware was designed especially to decrease spaces of light between the first slat and the head when the blind is closed. This effect is achieved through a tab on the upper part of the head that generates an overlap with the first slat, providing complete privacy, perfect visual comfort and protection against UV rays.

The Precious Metals slats are made of 95% recycled aluminum and are GreenGuard Indoor Air Quality Certified®, an added value for the final user in terms of health, energy savings, durability and wellbeing.



## CHARACTERISTICS

Light control: There are collections of slats with special 8%, 6%, 4% and 3% perforations that give them what is known as the Hunter Douglas "multivision" effect. This produces ideal control of the entry of light, imitating the effect achieved with the Screen fabrics.

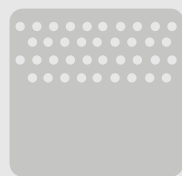

3%

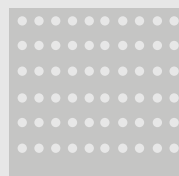

4%

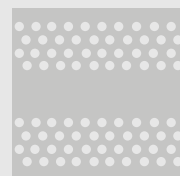

6%

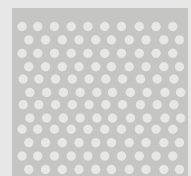

8%



## ENERGY EFFICIENCY

The range of slats that Hunter Douglas offers includes the Perforated 3% collection in Mirror Silver that has properties that make it 10% more reflective than a conventional slat, creating a protective barrier against sun radiation. In addition, these slats create 90% less heat than a normal slat, turning the shutter into an energy efficient curtain.

The Thermostop collection's high quality slats, which have a layer of special Thermostop paint on the upper side and high reflection paint on the lower side, help reduce the flow of heat through the slats, which reduces the radiator effect of the slat.

## OPERATION

Standard available  
in 16 mm, 25 mm and 50 mm

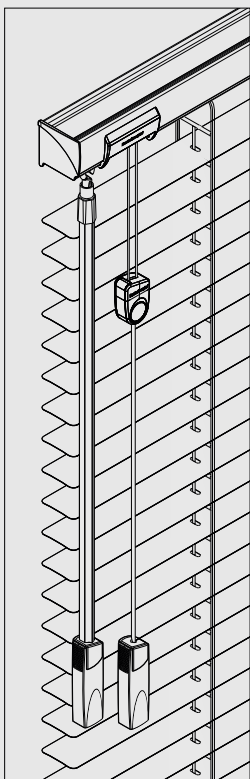

Classic and Premium Blind

Easy Control available  
in 16 mm and 25 mm

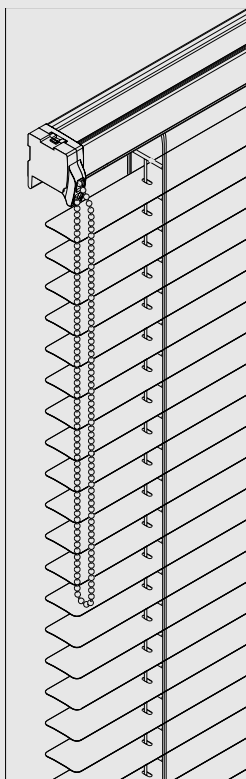

Operation that allows  
the shutter to be moved  
using a chain

Magnaview available  
in 25 mm and 50 mm

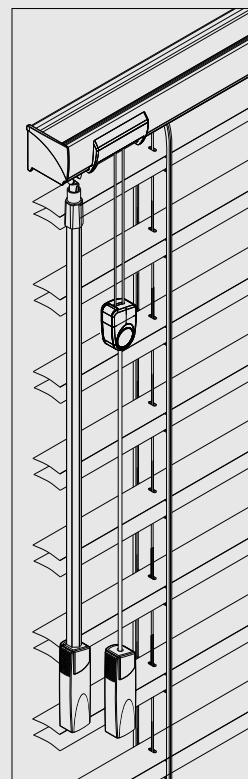

Operation that provides  
a visual field that is  
twice as large as that of  
a standard shutter

## OPTIONAL

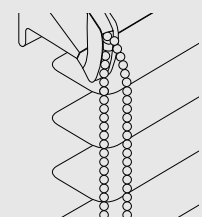

### EASY CONTROL

This option allows the shutter to be moved using a chain. Option available for the Classic 16 mm and Classic 25 mm lines.

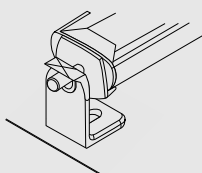

### BASE BRACKET

Used to affix the base of the blind and ensure that it does not move to the side. Essential for locations with air currents where the blind could be slanted. Option available for 16 mm and 25 mm lines.

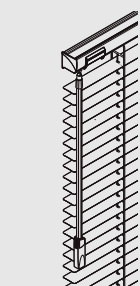

### ROD BRAKE

Like the blinds cord, the rod provides the option of selecting its height from nine different options from 250 mm to 3000 mm.

### MOTORIZED

This system allows all of the movements of the curtain and/or blind to be managed using a remote control. This also can be integrated into the external automation systems of your home.

# PRECIOUS METALS ALUMINUM BLINDS

Solar Control

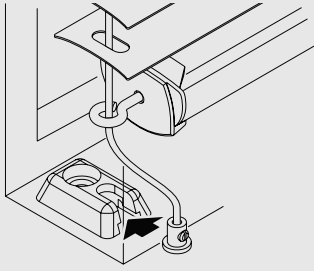

## LATERAL CABLE GUIDE

This element keeps the blind in the correct position when it is installed in tilt-and-turn windows or doors. These products can be installed inside or outside of a bay. Option available in standard movement for the Classic 16 mm and Classic 25 mm lines.



## TILT

This option includes a cord and rod that allow the blind to be manipulated. The cord raises and lowers the blind and the rod tilts the slats. Available in Horizontal 50 mm standard line action.

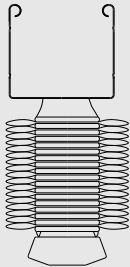

## LADDER OR RIBBON

To give the blind a bit more style, the classic ladder can be replaced with a decorative ribbon available in various colors and designs. This option is available in the Horizontal 50 mm standard line action.

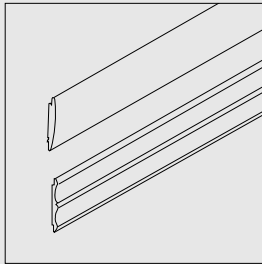

## VALANCE

The head of the blind can be covered with a Genuine Wood valance. This option is available for the Horizontal 50 mm line.

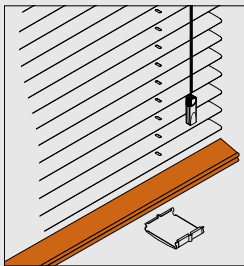

## WOODEN BASE

The aluminum base can be replaced with a 50 mm Genuine Wood base. This option is available for the Horizontal 50 mm standard and motorized action lines.

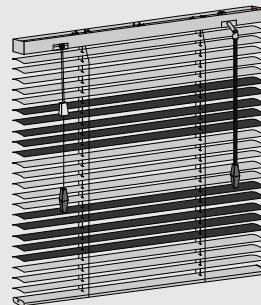
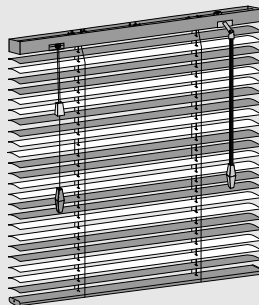

## MIXED SLATS

The bands are used to combine up to three colors from any collection on the blind. The number of bands that the blind will have is selected followed by the color and number of slats of each band. This option is available for the 16 mm and 25 mm lines. The base, cord and ladder come in a broad range of colors.

## INSTALLATION DIMENSIONS

Head for 16 mm and 25 mm lines

### WALL INSTALLATION

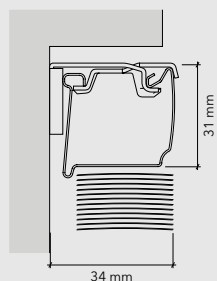

### ROOF INSTALLATION

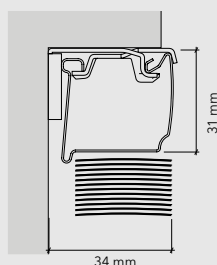

### RECESS INSTALLATION

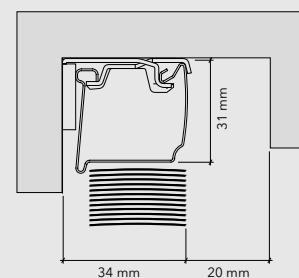

When the Premium blind is installed, it is important to consider the fact that it is raised with an incline towards the back because of the deviation of the perforations (Figure 1). As such, the spacing blocks must be used per the table below.

FIGURE 1

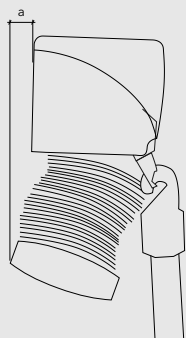

BLIND HEIGHT (mm)	DISTANCE "A" (mm)	N° SPACER BLOCKS
300	6	1
610	11	2
800	13	2
920	14	2
1220	17	3
1520	19	3
1820	21	3
2130	21	3
2440	22	3
2740	22	3
3000	22	3

### HEAD FOR 50 MM LINES

#### WALL INSTALLATION

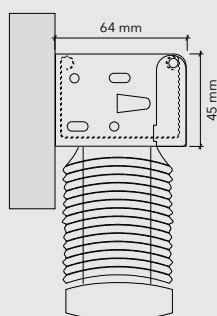

#### ROOF INSTALLATION

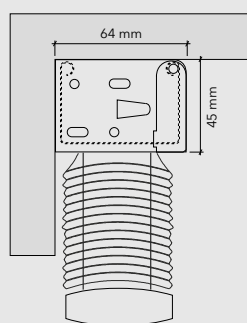

#### RECESS INSTALLATION

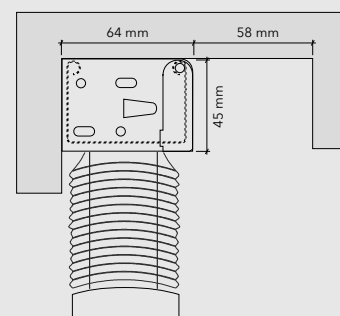

Note: The components of this product are constantly being improved and developed, so modifications may be made. The measurements listed on this Technical Sheet are expressed in millimeters (mm). In order to ensure that the product works correctly, the installation should always be handled by an authorized distributor using all of the accessories listed and in accordance with Hunter Douglas technical specifications.

# QUANTUM ROLLER BLINDS





# QUANTUM ROLLER BLINDS

Solar Control



The Quantum Roller Blind is fully integrated into the aesthetic of contemporary architecture thanks to its variety of fabrics, which range from transparency to complete opacity. It provides the perfect balance between decoration and sun control.

## CHARACTERISTICS

Quantum Roller blinds have three fundamental characteristics: versatility in design that improves the appearance and effectiveness of any space, high performance fabric and full freedom in specifications, providing hundreds of solutions in a single product.

### FUNCTIONALITY AND COMFORT

This line offers a full range of systems for matching the design, functionality and performance of any window. Its exclusive patented components facilitate installation, connection and operation with the highest quality and duration. The products are easy to install: the brackets allow for roof or wall installation without any additional components. The integrated level further facilitates installation.

The manual control systems provide Child Safety and contribute great functionality to large or coupled curtains.

The standard control systems with reduction provide much more comfortable operation. There is a Light Series control system and a more robust option for large dimensions in the Heavy Series.

The standard or extended brackets combined with the rear winding allow the curtains to pass over any handle or obstacle in their path.

The leading options allow for measurement adjustments to be made during the manufacturing process and provide easy, safe installation and use.

The aluminum tubes are high inertia, which results in a minimum tube shaft and thus a very flat fabric.

The level is a practical tool that allows us to correct small inclinations during installation, allowing for perfect fabric winding.

The coupled curtains allow for windows up to 15,2 m wide to be covered (when the maximum width is used, the height is limited to 2 m).



## SYSTEM CONFIGURATION

All systems can be used with chain, crank and motor. The motorized versions offer better light control and energy performance in combination with automation and domotics.

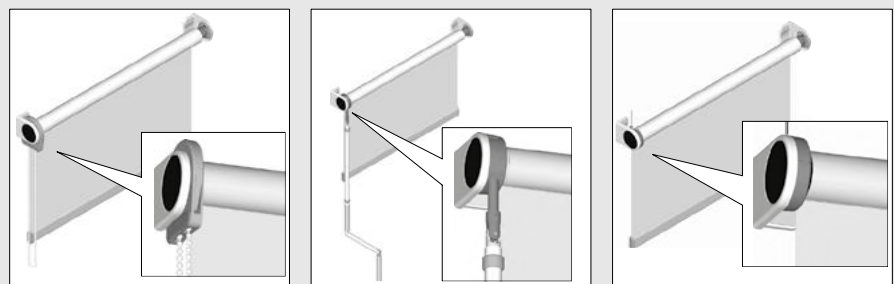

- Light Series: includes the Q31, Q37 and Q50 lines, which offer sizing up to 15 m<sup>2</sup> for individual curtains.
- Heavy Series: includes the Q52 and Q62 lines, which offer sizing up to 19 m<sup>2</sup> for individual curtains.

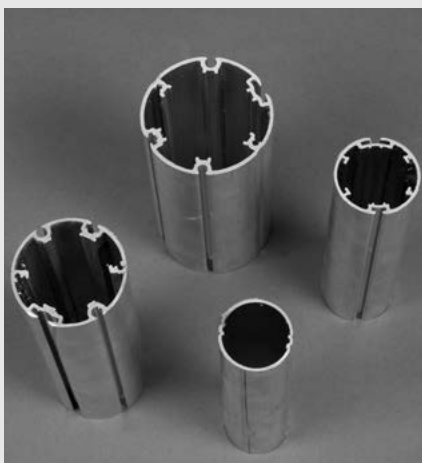



## SYSTEM CONFIGURATION

STANDARD

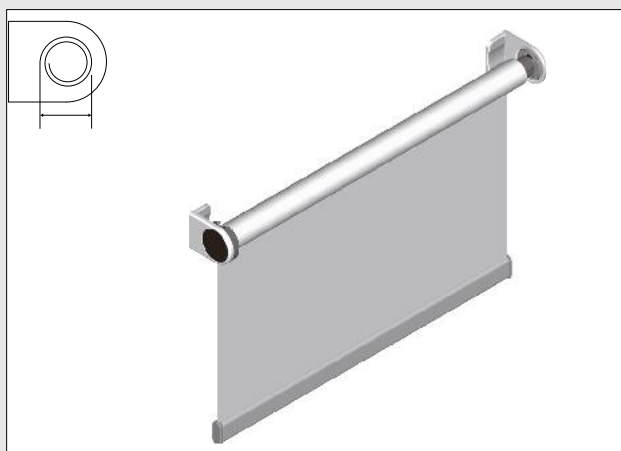

PROFILE PLUS (ONLY LIGHT SYSTEM)



FRONT OR VALANCE

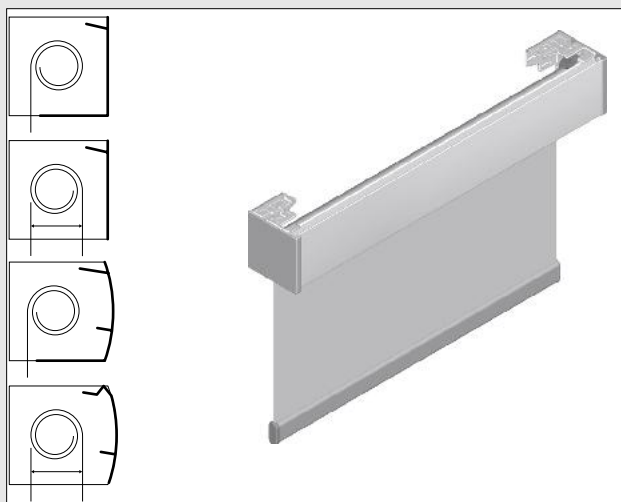

FRONT OR COMPLETE VALANCE

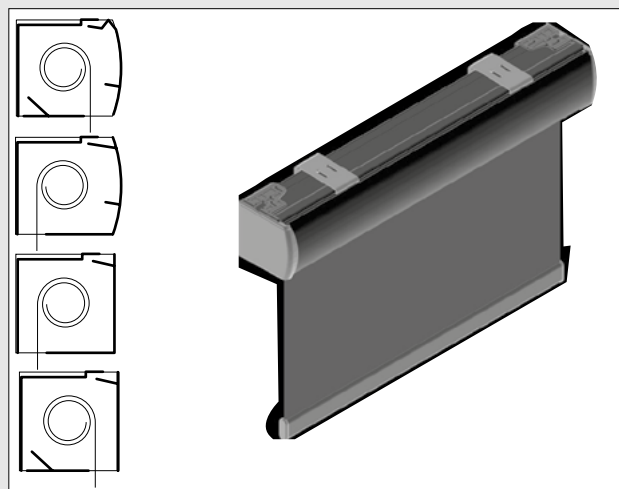

DUOLITE (ONLY LIGHT SYSTEM)

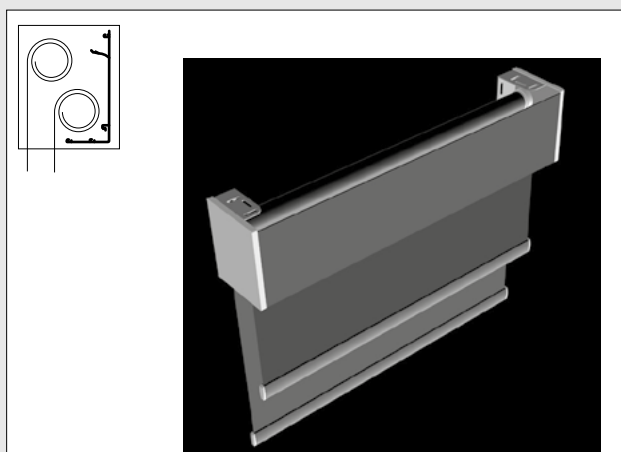

OVERLAPS (ONLY HEAVY SYSTEM)

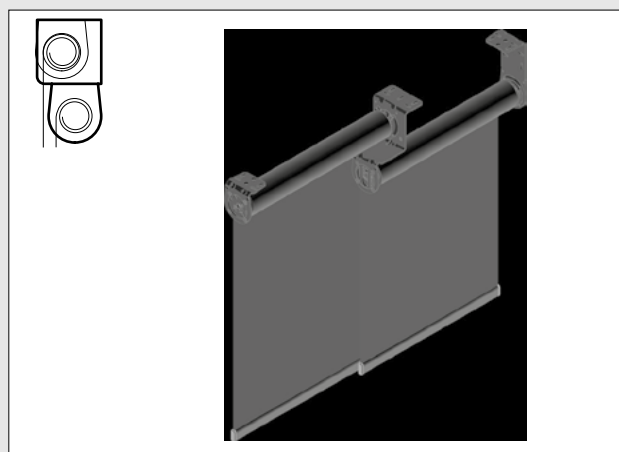

# QUANTUM ROLLER BLINDS

Solar Control

## SIZING

The project usually requires a homogeneous view. The largest blind will determine which system is required for the rest. Find the largest size on the table and identify which system is required for your project.

### SYSTEM, LINE AND ACTION SELECTION

In order to select the appropriate Light or Heavy system, review the following figures, which list the blind sizes, and explore the lines and actions available in each system to meet your specifications.

#### LIGHT SYSTEM QUANTUM ROLLER

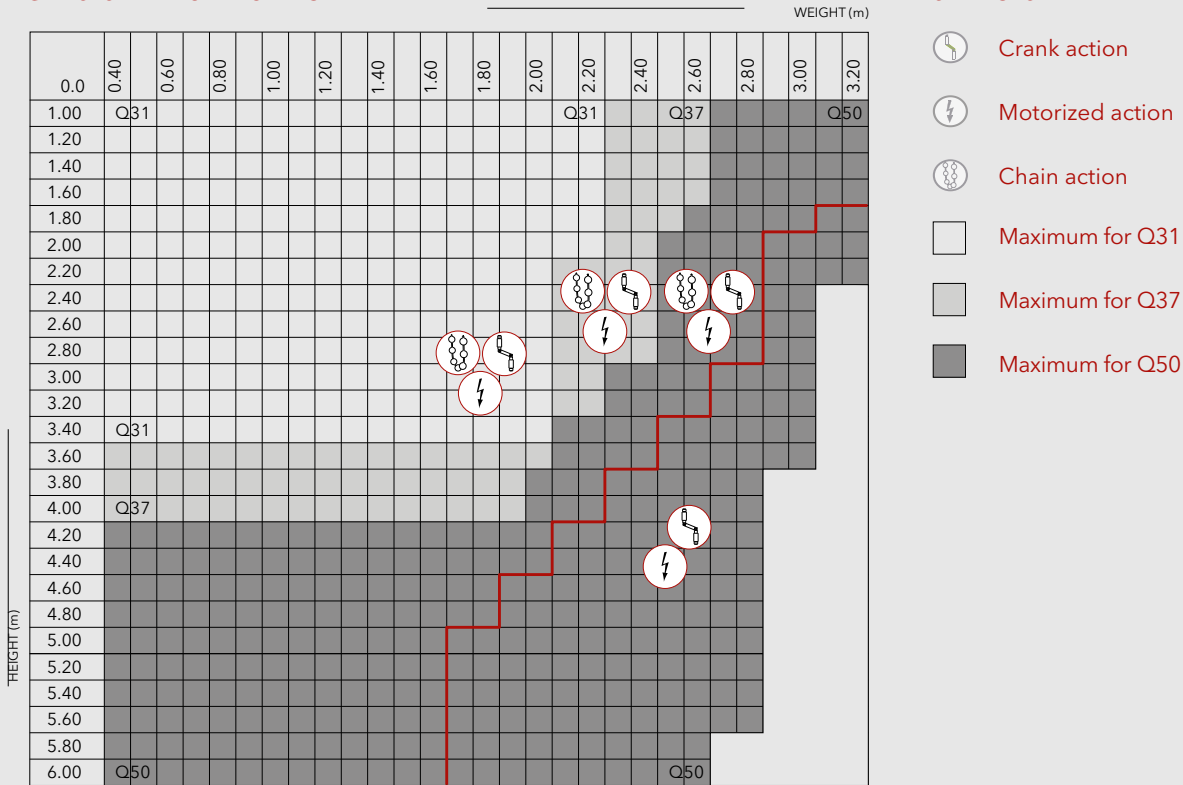

#### HEAVY SYSTEM QUANTUM ROLLER

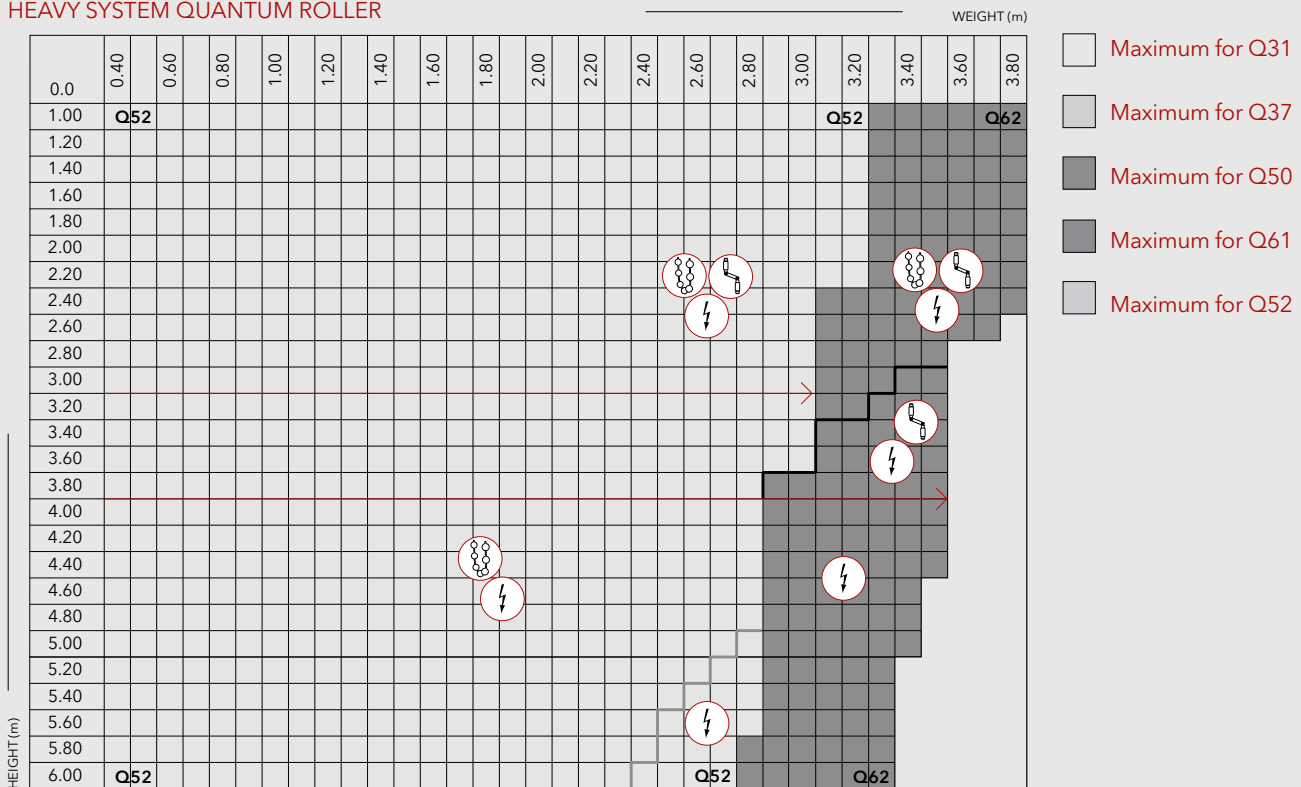

## DIMENSIONS FOR LIGHT SYSTEM INSTALLATION

### Q31, Q37 AND Q50 STANDARD, CHAIN ACTION

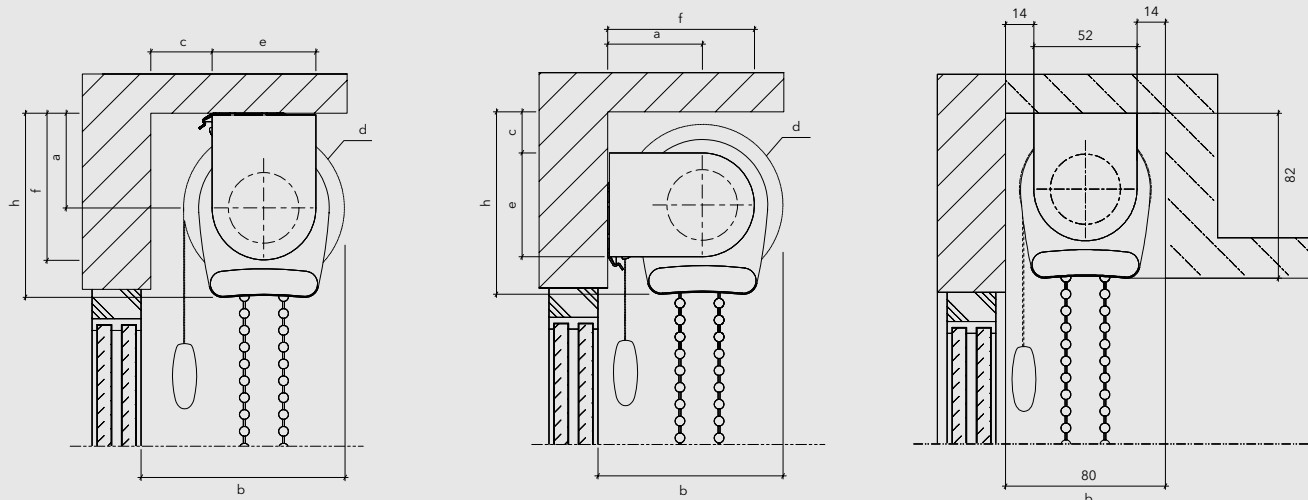

LIGHT SYSTEM	ROOF						WALL						RECESS					
	a	c	d	e	f	h	a	c	d	e	f	h	a	c	d	e	f	h
BRACKET 38	38	12	66	52	63	82	38	12	66	52	63	82	38	14	66	52	63	82
BRACKET 46	46	20	80	52	71	91	46	20	80	52	71	91	46	20	80	52	71	91
BRACKET 55	55	29	100	52	80	105	55	30	105	52	80	105	55	30	105	52	80	105

**HEIGHT IDENTIFICATION**  
 a. Measurement from bracket to axis  
 c. Bracket beginning to wall  
 d. Diameter of winding  
 e. Bracket end to wall  
 f. Full measurement of bracket  
 h. Max. winding height

### Q31, Q37 AND Q50 SPREAD, ACTION, CRANK

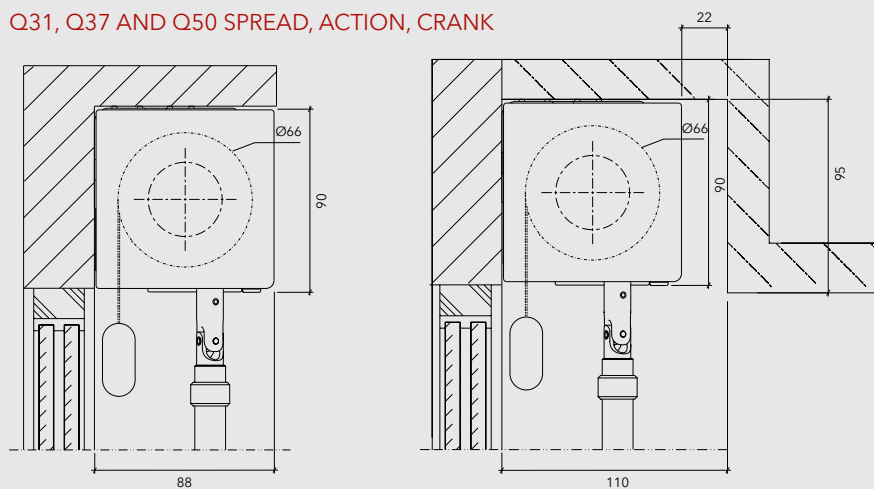

### Q31, Q37 AND Q50 DUOLITE, CHAIN ACTION

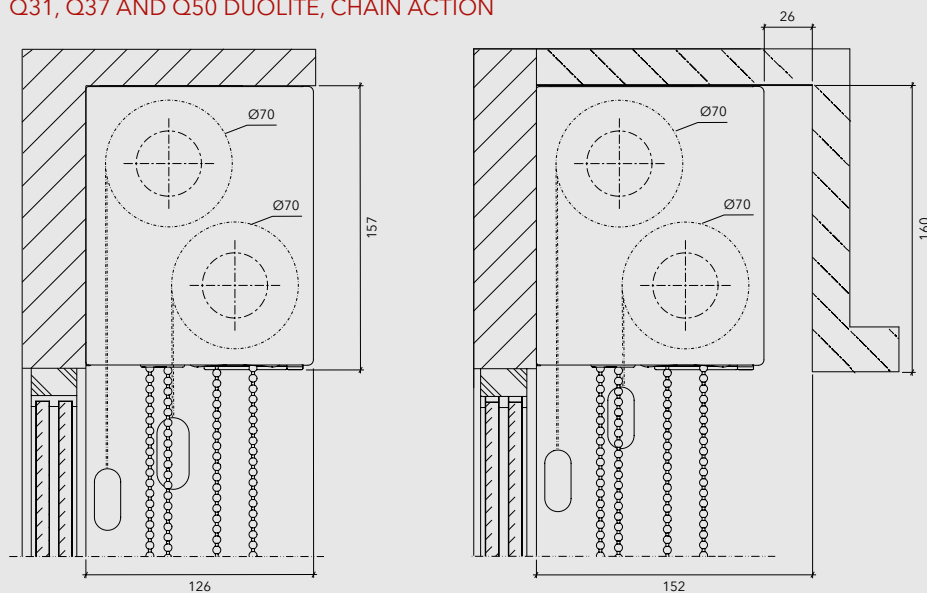

# QUANTUM ROLLER BLINDS

Solar Control

## HEAVY SYSTEM INSTALLATION DIMENSIONS

### Q52, Q62, CHAIN ACTION- STANDARD

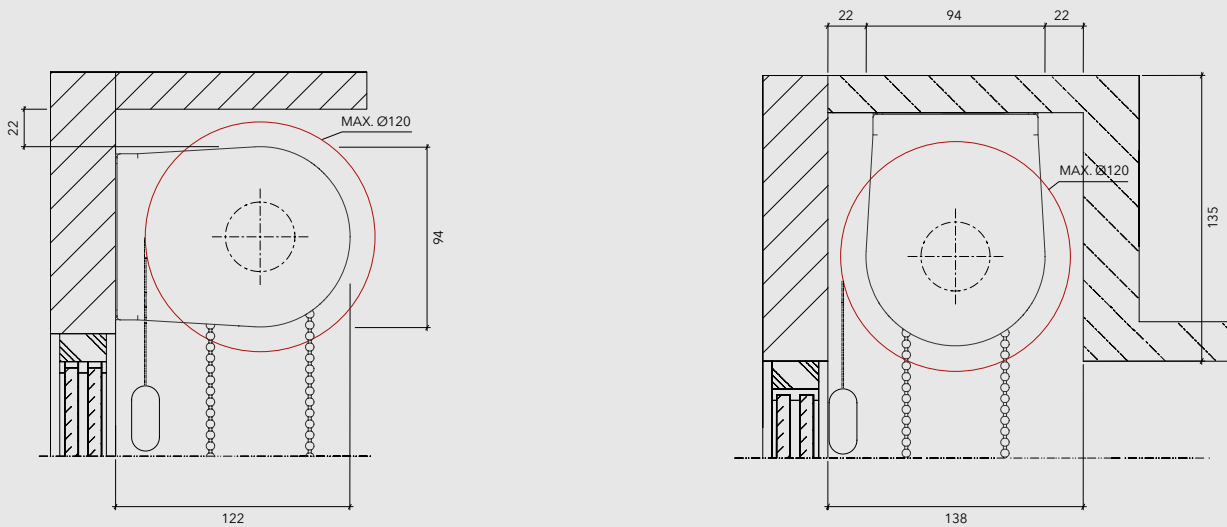

### Q52, Q62, CRANK ACTION- COMPLETE CURVE VALANCE

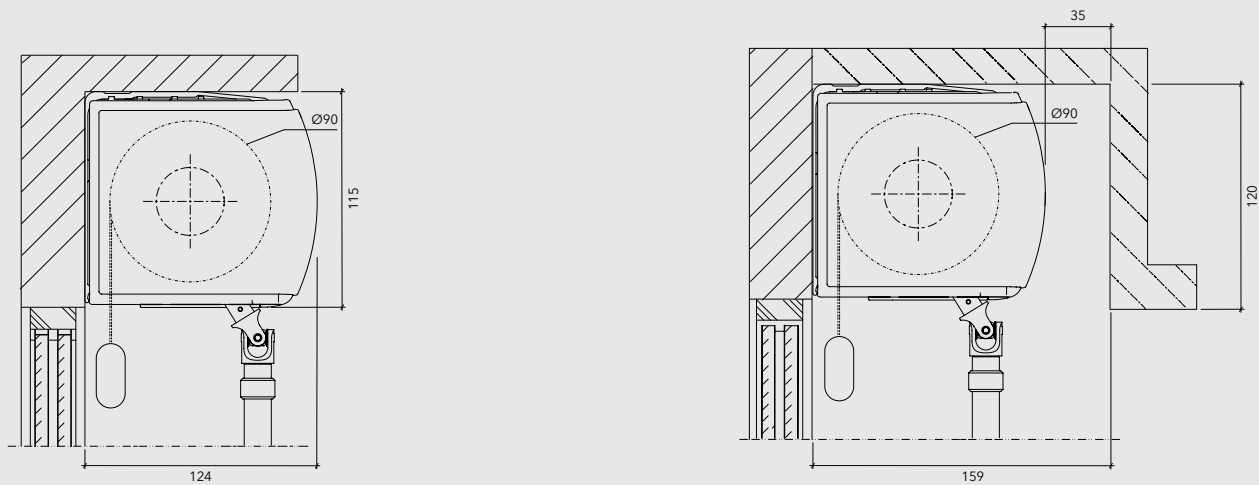

### Q11, Q37 AND Q50 Z BRACKET, CHAIN, CRANK AND M ACTION (AVAILABLE ONLY FOR Q52 AND Q62)

### Q50 QUANTUM® ROLLER CURTAINS WITH POWERRISE® MOTORIZATION

This product offers the ability to motorize large (up to 13 m<sup>2</sup>) curtains wirelessly using batteries, thus avoiding electric cabling that could impact the design and architecture. This approach also allows the user to control the curtains using a smart phone or tablet as long as they have access to the space's Wi-Fi network.

The Platinum App gives users the ability to adjust the position of the curtains at various times over the course of the day, simulating the residents' presence even if they are away.

The PowerRise® motor for the Q50 Quantum® Roller has a button in the head that allows the curtain to be moved even without electricity (use of batteries) or in the absence of the remote control.

It is compatible with curtains with a valance.

## FABRIC SELECTION

Fabrics are chosen based on various criteria such as location, façade orientation, building use and aesthetics.

- **Aesthetics and comfort:** Fabrics inside of a space provide a great deal of aesthetic value, reduce the temperature of the room by up to 3 degrees C, and maximize light control and acoustic comfort.
- **Fabric color:** Light colors facing the glass reduce solar gain and increase energy efficiency. They also transmit more natural light to the interior spaces.
- **Transparency:** Fabrics with smaller openings reduce visible life and protect the environment from harmful UV radiation while providing more privacy and security. Fabrics with wider openings guarantee good views of the exterior and provide more control of natural light.

TABLE OF TECHNICAL FACTORS AND INDICATORS

COLLECTION	OF	TS		RS		AS		TV		GTOTAL CL - S		UV BLOCKAGE	COMPOSITION
		MIN.	MAX.	MIN.	MAX.	MIN.	MAX.	MIN.	MAX.	MIN.	MAX.		
CONTRAST KOOLBLACK	5%	16%	18%	39%	47%	45%	35%	9%	11%	31%	32%	95%	36% Fv / 64% Vinyl
PANAMA 1%	1%	1%	14%	4%	75%	95%	11%	1%	11%	27%	37%	99%	36% Fv / 64% Vinyl
PANAMA 3%	3%	4%	18%	4%	73%	92%	9%	3%	13%	27%	37%	97%	36% Fv / 64% Vinyl
PANAMA 5%	5%	4%	22%	6%	71%	90%	7%	4%	17%	32%	69%	95%	36% Fv / 64% Vinyl
PANAMA 10%	10%	11%	25%	3%	66%	86%	9%	11%	23%	28%	37%	90%	36% Fv / 64% Vinyl
SILVERSCREEN 4%	4%	4%	6%	75%	77%	21%	17%	4%	6%	23%	23%	95%	64% PVC / 36% Fiberglass
ENVIROSCREEN 2%	2%	3%	4%	74%	74%	23%	22%	2%	4%	25%	25%	98%	100% Polyester Inherent FR

**SilverScreen 4% and EnviroScreen 2% fabric collections:** These options offer next-generation technology in solar reflectance developed in Europe with the highest quality and efficiency standards. Their metalized exterior reflects a high percentage of the sun's rays, allowing natural light to pass through and providing excellent control of light and heat regardless of the color chosen.



The SilverScreen collection has an aluminum layer with very low emissivity, which contributes directly to reducing energy consumption, generating considerable savings in heating and air conditioning costs and a decrease in CO<sub>2</sub> emissions. The products are also free of PVCs, which improves the interior climate.

The EnviroScreen 2% has a metalized interwoven weft that combines a limited opening coefficient with excellent visibility, guaranteeing visual and thermal comfort. Thanks to its high level of reflectiveness, it reduces heating and cooling costs and CO<sub>2</sub> emissions, minimizing the greenhouse effect.

This product is made of 100% recyclable materials and has anti-microbial properties.

# QUANTUM ROLLER BLINDS

Solar Control



The SilverScreen 4% and EnviroScreen 2% collections are made in compliance with international environmental standard ISO14001. They are Oeko-Tex and Greenguard certified, which means that their use will contribute to obtaining LEED, Green Star and BREEAM certification for your projects.

Thermal comfort benefits:

- Controls temperature, refreshing spaces during the summer and holding in heat in the winter
- Significantly reduces heat gain produced by solar radiation

Visual comfort benefits:

- 2% and 4% opening coefficients provide excellent vision through the fabric while maintaining intimacy
- The highest solar reflectance of 82% provides excellent control of light
- Glare control
- Use of natural light
- Chromatic reproduction and independence in color
- The two collections are available in a wide range of colors
- Uniformity in façades

Economic benefits:

- Excellent solution for reducing heating and cooling needs in buildings
- Reduces spending on heat by up to 15%, spending on air conditioning by up to 35% and spending on lighting by 35%
- Sustainable and durable product
- Does not require significant maintenance

Health benefits:

- Neutralizes PVC emissions
- Lower CO<sup>2</sup> emissions
- Antibacterial
- Anti-static, retains less dust
- Flame retardant
- Allows spaces to be ventilated

CERTIFICATIONS:

- CONFIDENCE IN TEXTILES: Tested for harmful substances according to Oeko-Tex® Standard 100
- GREENGUARD: Indoor Air Quality Certified
- U.S. GREEN BUILDING COUNCIL MEMBER
- GREEN BUILDING COUNCIL OF AUSTRALIA
- DUTCH GREEN BUILDING COUNCIL
- ECOSPECIFIER
- TÜV RHEINLAND CERTIFIED: Certified Management System. DIN EN ISO:14001, EN ISO:9001

- Solar Transmission (ST): Percentage of solar radiation that passes through the fabric. A low number indicates good reduction of heat and glare.
- Solar Reflection (SR): Percentage of solar radiation reflected towards the outside by the fabric. A high number indicates good reflection of solar energy.
- Solar Absorption (SA): Percentage of solar radiation absorbed by the fabric. A low number indicates that the fabric provides good insulation and absorbs less solar energy/heat.

Solar radiation is always partially transmitted through the fabric and reflected and absorbed. The sum of the three factors is equal to 100% of solar radiation.

## HEAT BLOCKING FACTORS

-Coefficient of SC Shade (relative value): This is the percentage that indicates solar heat gain through the glassed system (glass + fabric) compared to the heat gain through clear 6 mm glass.  $SC = g_{total} / 0,87$ .

-g total solar factor (absolute value): This is the percentage relationship that indicates the solar heat gain through the glassed system (glass + fabric) compared to the heat gain if there were no glassed system.

## OPTICAL FACTORS

Visible light transmission, VT: Percentage of the visible light (shine) that passes through the fabric. A low number indicates good glare reduction.

ST, SR, SA OF SOLAR RADIATION IMPACTING PROTECTIVE FABRIC

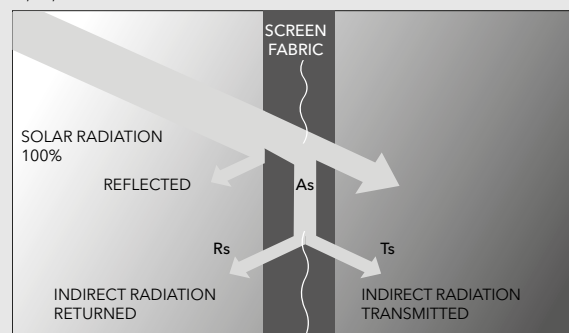

EXTERNAL ENVIRONMENT | INTERNAL ENVIRONMENT

## OPTIONAL CONFIGURATIONS

### STEEL BRACKET/ DESIGN BRACKET WITH OPTIONAL LEVEL

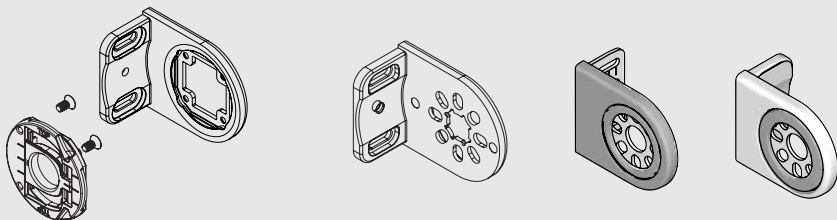

WITH LEVEL

WITHOUT LEVEL

### OPTIONAL LATERAL CABLE GUIDE/ LATERAL PROFILE GUIDE

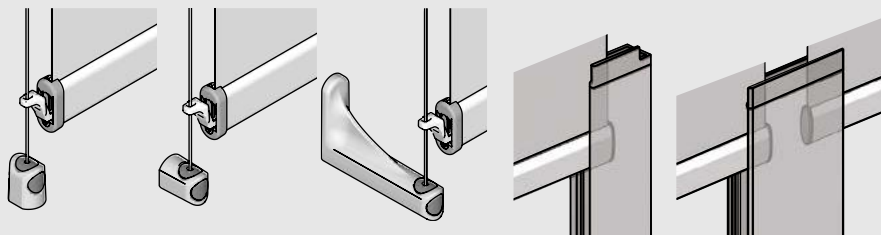

TO BASE

TO WALL

TO WALL ONLY REAR WINDING

LATERAL GUIDE

CENTRAL GUIDE

The translucency of the lateral profile guides is only used to provide a more complete explanation.

### STANDARD COUPLED GROUP ACTION, CRANK OR MOTORIZED, 90° OR 45° CONNECTOR

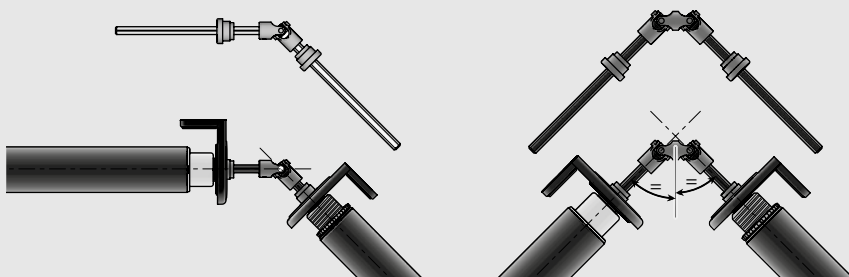

### OPTIONAL COUPLER WITH ALIGNER, COUPLED 0 - 15°

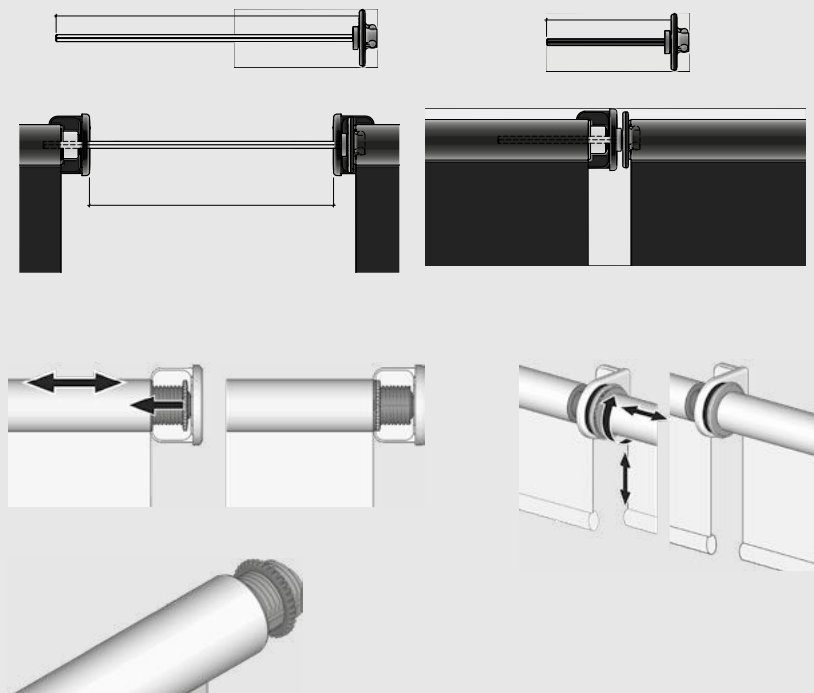

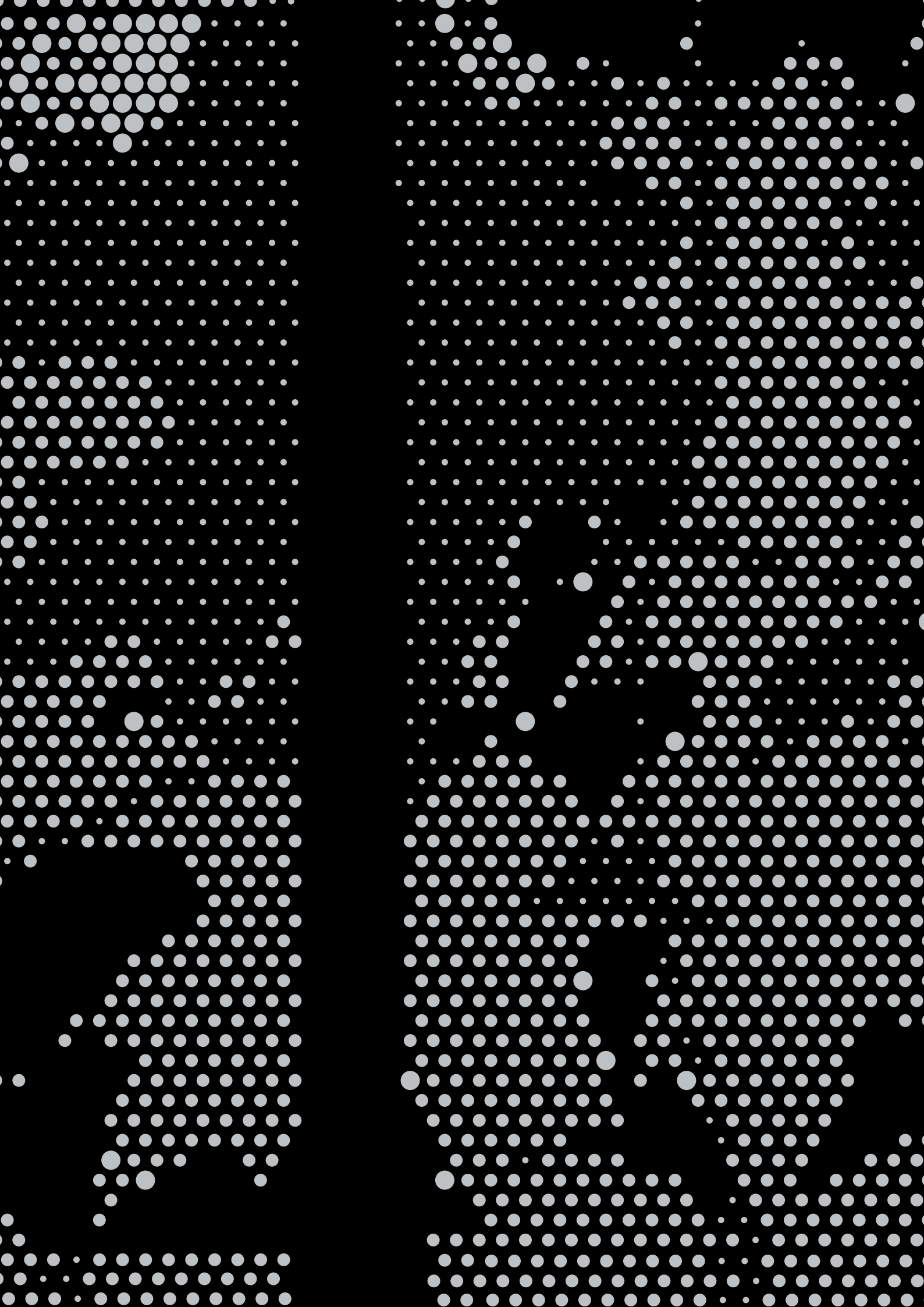





**FINNISHES**

# COLORS & PAINTS

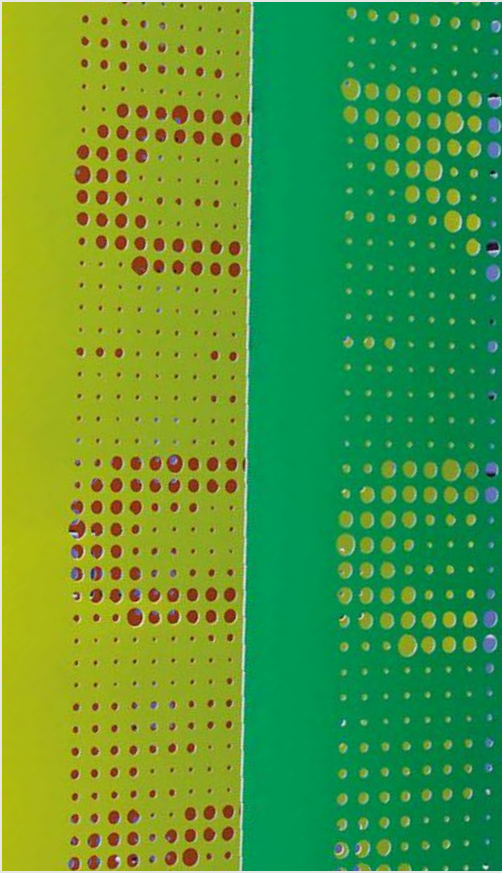



# COLORS & PAINTS

Solar Control | Finishes

The use of paints on metallic bases in Hunter Douglas products is not only for decorative purposes in which the color scheme is used to give the product an aesthetic appearance. It also provides protection for surfaces affected by humidity, corrosion and other conditions.

The paints used by Hunter Douglas for its metallic products provide excellent color stability properties and provide additional characteristics such as being very easy to clean.

## TYPES OF PAINT

---

### LIQUID PAINTS

This type of covering is applied using rollers with liquid paint. It is used to create various types of finishes. In general, different colors are mixed, providing streaks or different textures.

### POLYESTER

This is the most frequently used paint type in Hunter Douglas processes. This type of paint can be used with various textures, both smooth and sandy. There are various types of shines or mattes and the paint has a thickness of 25 micras.

POLYESTER APPLICATION DIAGRAM

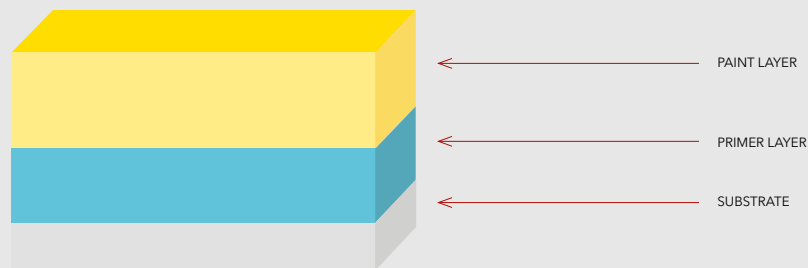

### PVDF2

This type of paint provides a great deal of protection to the products on which it is applied. It is available in a variety of colors and provides a uniform, architectural finish in brilliant, lasting colors.

### ULTRA COOL OR COOL ROOF

All PVDF paints are Ultra Cool or Cool Roof because they have high reflectance pigment that can be certified because of its solar reflectance index (SRI). This reduces the product's surface temperature and protects it from UV radiation.

PVDF APPLICATION DIAGRAM

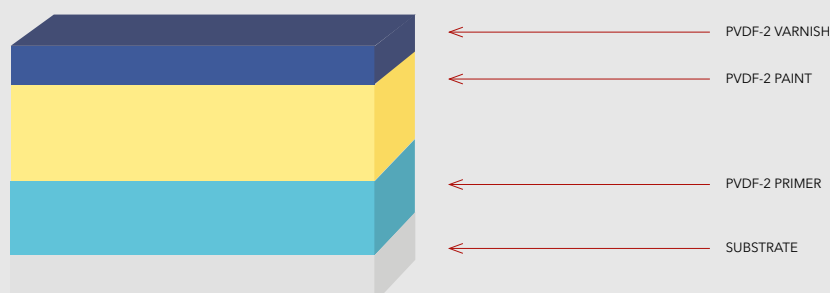

## RECOMMENDED TYPES OF SPACES AND PAINTING TYPES

TYPE OF SPACE	CHARACTERISTICS	PRIMARY MATERIAL	PAINT TYPE	SERVICE TIME (*)
URBAN OR RURAL	SPACE WITHOUT THE PRESENCE OF ACIDS URBAN AND RURAL AREAS	ZINC-ALUMINUM	POLYESTER	OVER 10 YEARS
SMOOTH MARINE LIGHT INDUSTRIAL	OVER 400 M FROM THE SEA, INDUSTRIAL AREA, LOW POLLUTION	ZINC-ALUMINUM	POLYESTER	OVER 10 YEARS
URBAN OR RURAL	AREA WITHOUT THE PRESENCE OF ACIDS URBAN AND RURAL AREAS	ALUMINUM/ ZINC-ALUMINUM	PVDF-2	OVER 20 YEARS
SMOOTH MARINE LIGHT INDUSTRIAL	OVER 400 M FROM THE SEA, INDUSTRIAL AREA, LOW POLLUTION	ALUMINUM/ ZINC-ALUMINUM	PVDF-2 PLUS	OVER 20 YEARS
MEDIUM MARINE	BETWEEN 100 AND 400 M FROM THE SEA, COASTLINE, INDUSTRIAL AREA	ALUMINUM	PVDF-2 XL	OVER 20 YEARS
SEVERE MARINE SEVERE INDUSTRIAL	LESS THAN 100 M FROM THE SEA, AGGRESSIVE AREAS, MINING	ALUMINUM	PVDF-2 XL PLUS	OVER 20 YEARS

### POWDER PAINT







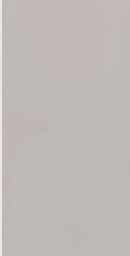
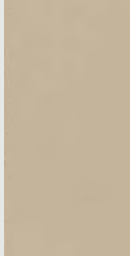

This type of paint is applied as a dry powder. It is used to create a hard finish that is more resistant than conventional paint. The paint is  $70 \pm 10$  micras thick. The process is completed in facilities that are equipped with a curing oven, cabins for application using electrostatic pistols, and an air transport chain in which the products are hung. This type of paint is mainly used for thicker elements and products such as extruded aluminum profiles, Screenpanel XL and Plank XL.

## TYPES OF COLORS AND FINISHES

### TYPES OF COLORS

#### INTERIOR COLORS

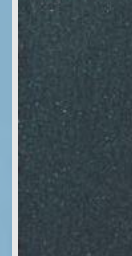
Colors for interior application present ranges, tones and brightness that are appropriate for an environment with a different light intensity, limited exposure to ultraviolet rays and diverse atmospheric agents. The emphasis is placed on greater variety and chromatic purity that is adequate for combining the various forms and styles of architecture and interior design. The colors are characterized by having a 15% brightness composition.

									
Opaque Porcelain 15% brightness	Waffle 15% brightness	Pistachio 15% brightness	Mustard Yellow 15% brightness	Mango 15% brightness	Poppy Red 15% brightness	Natural Aluminum 15% brightness	Sky 15% brightness	Deep Sea 15% brightness	Opaque Anodized 15% brightness

#### EXTERIOR COLORS

Colors for exterior applications have been formulated considering the quality requirements necessary for their exposure to atmospheric agents such as ultraviolet radiation, urban pollution and weather agents. Exterior colors have a brightness composition of 45% and 15% for products that require flatness such as Quadroclad, Multipanel F, Tejas and Screenpanel surfacing.

									
Aluminum 45% brightness	Anodized 45% brightness	Sand 45% brightness	Golden 45% brightness	Black Coffee 45% brightness	Copper 45% brightness	Fire 45% brightness	Mandarin 45% brightness	Canary yellow 45% brightness	Lime green 45% brightness

**WOODGRAINS | MINERALGRAINS**





# WOODGRAINS | MINERALGRAINS

Solar Control | Finishes

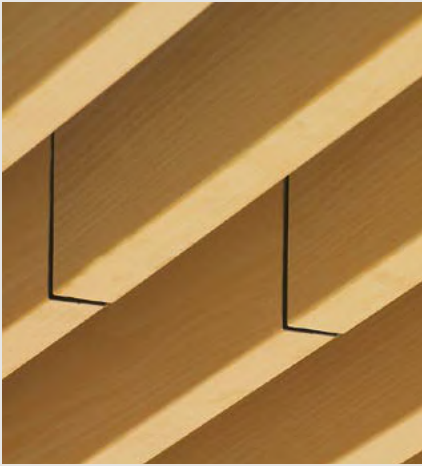

In view of the fact that wood has always required a great deal of care and maintenance in exterior applications, Hunter Douglas has launched a new finish for all metallic architectural products that provides the quality of wood but without the need for constant maintenance. Using Woodgrains technology, the company has designed a new collection of finishes for interior and exterior use. The line features a wide range of colors and woodgrains applicable to ceiling, louvre, covering and surfacing products for interior or exterior walls.

Note: For exterior operations, PVDF translucent varnish with UV protection is recommended.

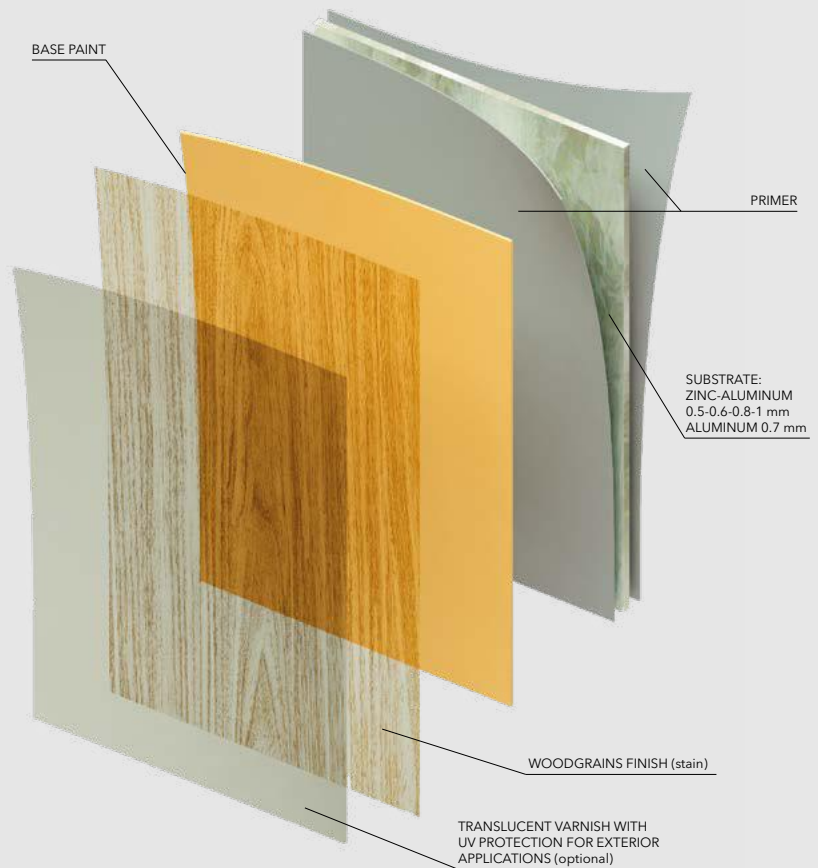
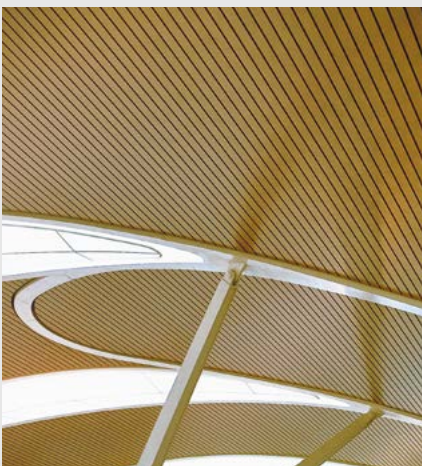

## TYPES OF WOODGRAINS OR PATTERNS

Cathedral



Radial





## WOODGRAINS COLORS

---

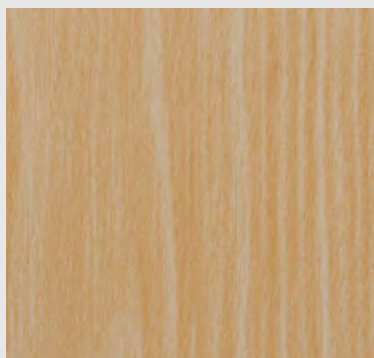

Aged Poplar



Medium Rusted Larch



Dark Rusted Larch

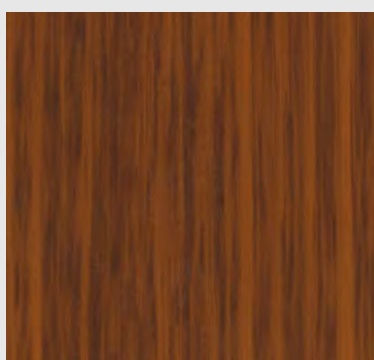

Chestnut

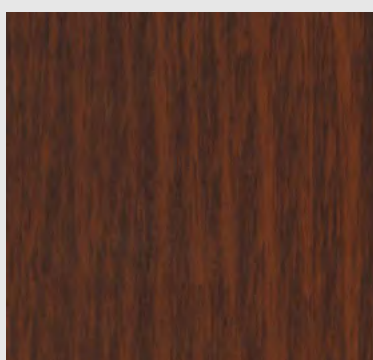

American Cedar

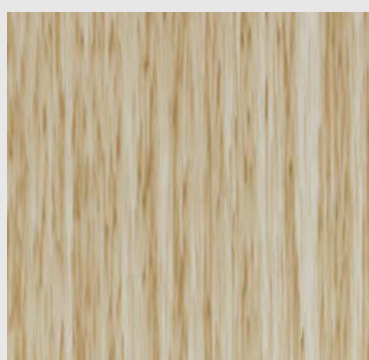

Chinese Cypress



Eucalyptus



Dark Walnut

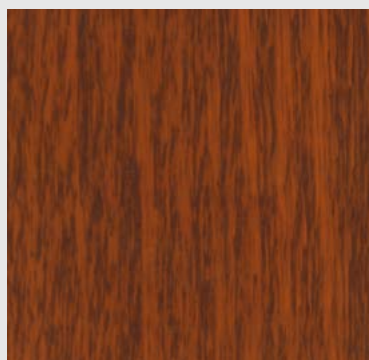

Native Cedar

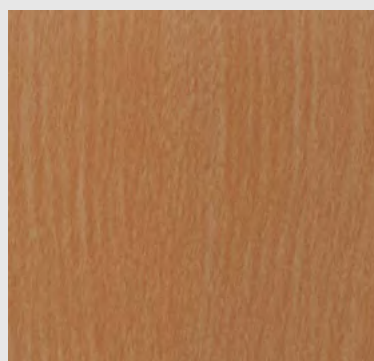

Haya

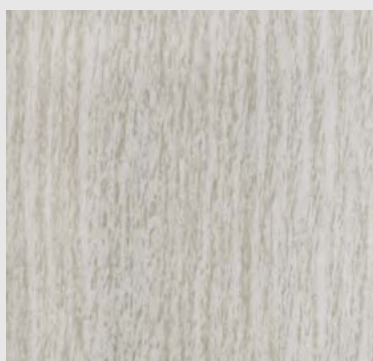

Native Cedar



Black Ebony

## MINERALGRAINS COLORS

---

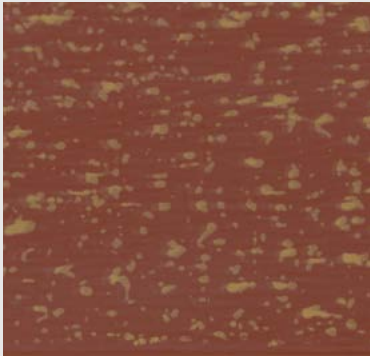

Sand



Light Brown



Cyan

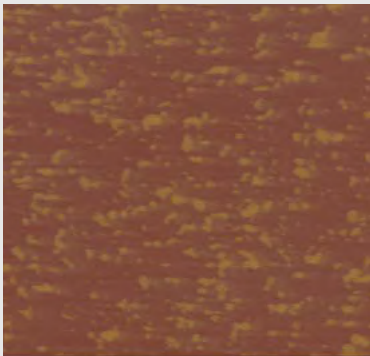

Russet



Turquoise

Note: Special colors can be developed for projects over 500 m<sup>2</sup>.

Using the same technology employed in Woodgrains, a finish can also be produced for all metallic products that are similar to weathering steel or rusted copper. Mineralgrains is recommended in applications in which the use of weathering steel or copper is not feasible.

## FINISHES

---

### SANDED

This application provides a natural material finish like terracota and provides warmth and durability to the exterior. It offers great flexibility, multiple possibilities and is available in a large variety of colors and textures through the use of pigment blending.

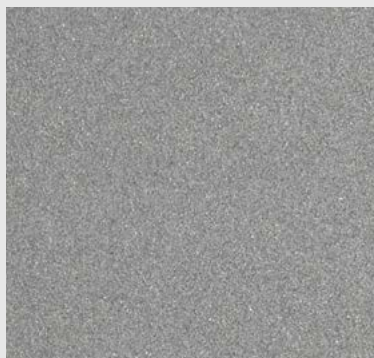

Natural Aluminum 7163 15%  
Fine sanded



Blackboard 4577 25%  
Fine sanded



Blackboard 4577 25%  
Thick sanded

Note: The sanded finish option is not available for all products. Please check with the Specification Department.

### PEARLS

This line is used on any type of metallic application, preferentially to give a product more brightness, protection and durability. This finish is only available for certain products. Check with the Specification Department.



Pearled Fire 5360 45%

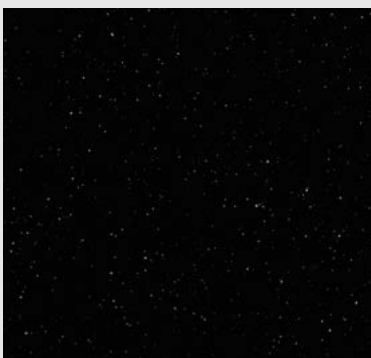

Black Pearl 3070 45%

Note: The components of this product are constantly being improved and developed, so modifications may be made. The measurements listed on this Technical Sheet are expressed in millimeters (mm). In order to ensure that the product works correctly, the installation should always be handled by an authorized distributor using all of the accessories listed and in accordance with Hunter Douglas technical specifications.

# PERFORATIONS





# PERFORATIONS

Solar Control | Finishes



Hunter Douglas has a wide range of perforated materials which present diverse applications and finishes. The many functions that perforated materials efficiently perform include absorbing, covering, decorating, filtering, protecting, separating and ventilating. The size and placement of the perforations, thickness of the shading metal skin and material are key when it comes to adding design to functionality.

Thanks to their attractiveness and versatility of form and function, perforated skins allow for complete personalization of interior and exterior spaces for ceilings, surfacing, façades and awnings, achieving a great variety of possible designs based on the requirements of each project. Hunter Douglas uses high-precision equipment and machinery and a large variety of perforating tools to satisfy all of its clients' needs. These perforations are classified as:

- Standard perforations
- Special perforations

## CONSIDERATIONS AND VARIABLES:

- Perforated surface (panels)
- Material and thickness
- Type and characteristics of the perforations
- Image (if applicable)
- Perforation pattern (if applicable)
- Distance between perforations, percentage of open area per m<sup>2</sup>
- Number of perforations per m<sup>2</sup>



## PERFORATIONS

### STANDARD PERFORATIONS

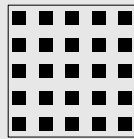

# 406

Ø 5 mm

25% open

← 5 mm  
↓ 5 mm

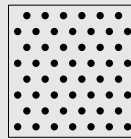

# 103

Ø 2,95 mm

20% open

← 3,35 mm<sup>+0,05</sup>  
↓ 2,5 mm<sup>+0,05</sup>



### THEMATIC PERFORATIONS

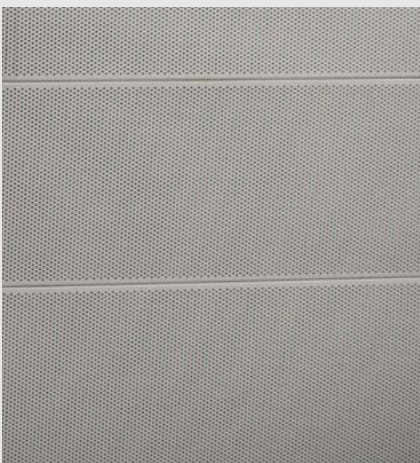
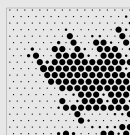
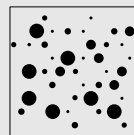

## TYPES OF PERFORATIONS

Special patterns are all perforations formed and placed outside of the structure of a standard pattern.

INTERNATIONAL STANDARD ISO 7806-1983 (E)

To describe the form and placement of the perforations

### TYPE OF PERFORATIONS

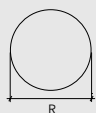

R= Round perforations



C= Squared perforations

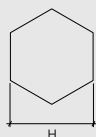

H= Hexagonal perforations

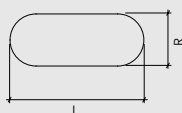

LR= Long rounded perforations

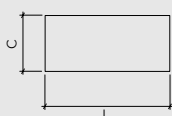

LC = Rectangular perforations

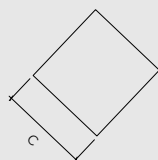

CD= Squared perforations

### PLACEMENT OF PERFORATIONS

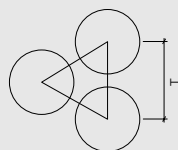

T= Offset

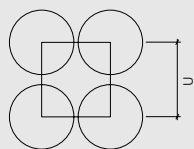

U= Square

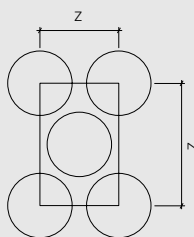

Z= Staggered

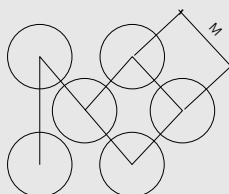

M= Diagonal

### EXAMPLES

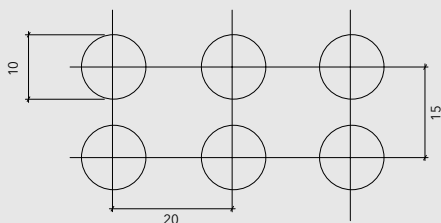

R 10 U 15X20

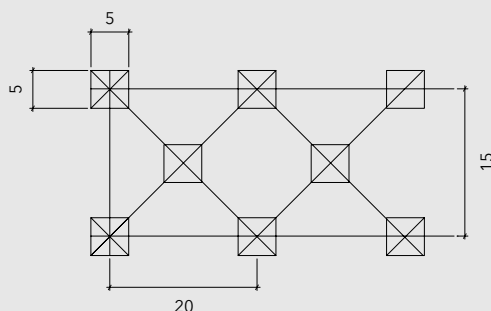

C5Z 15X20

# PERFORATIONS

Solar Control | Finishes

## DEFINITIONS

Description of a perforated pattern

- |  |   |   |
|--|---|---|
| 1 Length                                       | 31 Alternate parallel to width            | 21 Longitude of the triangular routed perforation |
| 2 Width  | 32 Alternate parallel to length           | 22 Length of the triangular routed perforation    |
| 3 Veneer thickness                             | 33 Alternating tiers parallel to width    | 23 Z-alternates parallel to width                 |
| 4 Longitudinal central                         | 34 Alternating tiers parallel to length   | 24 Z-alternates parallel to length                |
| 5 Valances to width or in heads                | 35 Tiers parallel to width                |   |
| 6 Hole size                                    | 36 Tiers parallel to length               |   |
| 7 Triangle in the direction of the perforation | 37 Distance between centers               |   |
| 8 Inverted triangle                            | 38 Rows of perforations                   |   |
| 9 Squared                                      | 39 Length of the rounded long perforation |   |
| 10 Diagonal                                    | 40 Width of the rounded long perforation  |   |

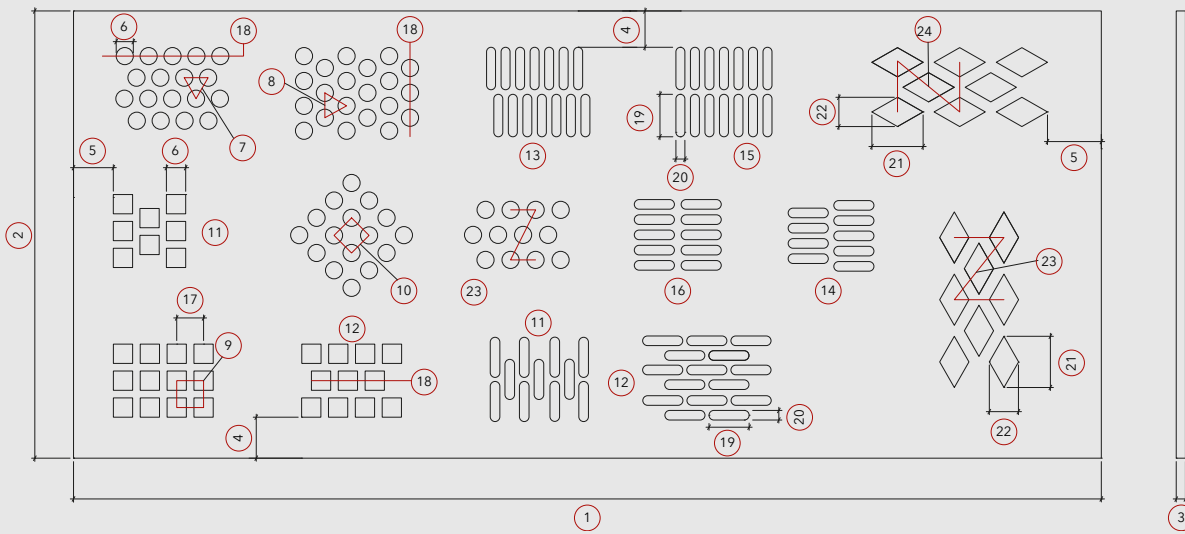









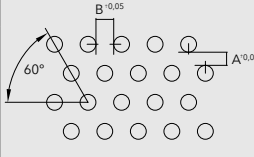

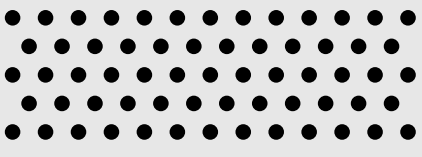
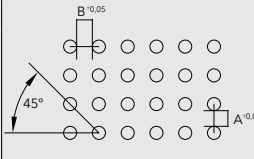

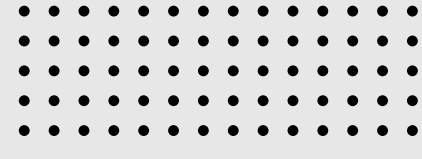
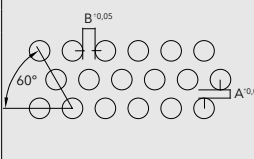
## PERFORATION FORMULAE

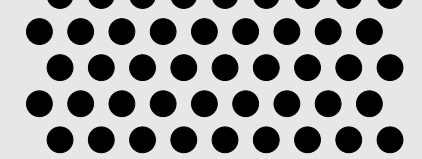
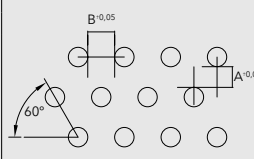
PLACEMENT OF HOLES	DESCRIPTION	% OPEN AREA	NUMBER OF PERFORATIONS
	R-T	$\frac{R^2 \times 90,69}{T^2}$	$\frac{1.154.700}{T^2}$
	R-U	$\frac{R^2 \times 78,5}{U1 \times U2}$	$\frac{1.000.000}{U1 \times U2}$
	C-U	$\frac{C^2 \times 100}{U1 \times U2}$	$\frac{1.000.000}{U1 \times U2}$
	C-Z1XZ2	$\frac{C^2 \times 100}{0,5 \times (Z1 \times Z2)}$	$\frac{1.000.000}{0,5 \times (Z1 \times Z2)}$
	L-RXZ2	$\frac{R \times L - 0,215R^2 \times 100}{0,5 \times (Z1 \times Z2)}$	$\frac{1.000.000}{0,5 \times (Z1 \times Z2)}$
	LC-Z1XZ2	$\frac{100 \times L \times C}{0,5 \times (Z1 \times Z2)}$	$\frac{1.000.000}{0,5 \times (Z1 \times Z2)}$

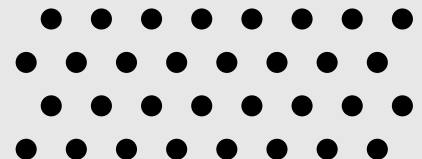
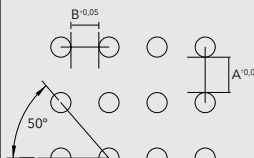

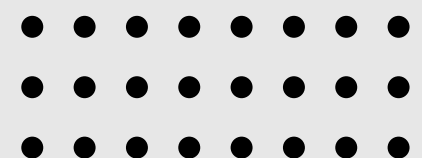
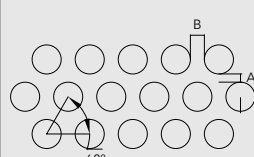
## STANDARD PERFORATIONS

DESIGN		DIMENSIONS IN mm				20% OPEN AREA	NUMBER OF PERFORATIONS m <sup>2</sup>	
		A	B	∅	<			
103 Available for material and thickness: Zinc-aluminum 0.4, 0.5 and 0.6   Aluminum 0.7 mm 		2,5	3,35	2,95 <sup>-0,05</sup>	60°	DIRECTION OF THE PERFORATION IN RELATION TO THE LOCK 	#28,665	
DIST. BETWEEN LONGITUDINAL PERFORATIONS	DIST. BETWEEN TRANSVERSAL PERFORATIONS	DIAMETER OF THE PERFORATION	ANGLE OF THE PERFORATION					
106 Available for material and thickness: Zinc-aluminum 0.4, 0.5 and 0.6   Aluminum 0.7 mm 		3	3	2,5 <sup>-0,05</sup>	45°	DIRECTION OF THE PERFORATION IN RELATION TO THE LOCK 	#33,124	
DIST. BETWEEN LONGITUDINAL PERFORATIONS	DIST. BETWEEN TRANSVERSAL PERFORATIONS	DIAMETER OF THE PERFORATION	ANGLE OF THE PERFORATION					
109 Available for material and thickness: Aluminum 1.2 mm 		2,12	3	5 <sup>+0,05</sup>	60°	DIRECTION OF THE PERFORATION IN RELATION TO THE LOCK 	#17,875	
DIST. BETWEEN LONGITUDINAL PERFORATIONS	DIST. BETWEEN TRANSVERSAL PERFORATIONS	DIAMETER OF THE PERFORATION	ANGLE OF THE PERFORATION					
110 M1 Available for material and thickness: Zinc-aluminum 0.5, 0.6 and 1; Aluminum 0.7 mm   Weathering steel 0.6 and 1 mm 		4,25	5,53	3,9 <sup>+0,05</sup>	60°	DIRECTION OF THE PERFORATION IN RELATION TO THE LOCK 	#12,810	
DIST. BETWEEN LONGITUDINAL PERFORATIONS	DIST. BETWEEN TRANSVERSAL PERFORATIONS	DIAMETER OF THE PERFORATION	ANGLE OF THE PERFORATION					
110 M3 Available for material and thickness: Zinc-aluminum 0.5, 0.6, 1   Aluminum 0.7   Weathering steel 0.6 and 1 mm 		7	5,53	3,9 <sup>+0,05</sup>	50°	DIRECTION OF THE PERFORATION IN RELATION TO THE LOCK 	#9,555	
DIST. BETWEEN LONGITUDINAL PERFORATIONS	DIST. BETWEEN TRANSVERSAL PERFORATIONS	DIAMETER OF THE PERFORATION	ANGLE OF THE PERFORATION					
111 Available for material and thickness: Zinc-aluminum 1   Weathering steel 1 mm 		2,67	4,55	9,52 <sup>+0,05</sup>	60°	DIRECTION OF THE PERFORATION IN RELATION TO THE LOCK 	#5,822	
DIST. BETWEEN LONGITUDINAL PERFORATIONS	DIST. BETWEEN TRANSVERSAL PERFORATIONS	DIAMETER OF THE PERFORATION	ANGLE OF THE PERFORATION					

# PERFORATIONS

Solar Control | Finishes

## STANDARD PERFORATIONS

112 Available for material and thickness: Zinc-aluminum 0.5, 0.6 and 1   Weathering steel 0.6 and 1 mm							
DESIGN	DIMENSIONS IN mm				20% OPEN AREA	NUMBER OF PERFORATIONS m <sup>2</sup>	
	A	B	Ø	<			
	18	4	10	45°	↑	#2,592	
DIST. BETWEEN LONGITUDINAL PERFORATIONS	DIST. BETWEEN TRANSVERSAL PERFORATIONS	DIAMETER OF THE PERFORATION	ANGLE OF THE PERFORATION	DIRECTION OF THE PERFORATION IN RELATION TO THE LOCK			

113 Available for material and thickness: Zinc-aluminum 0.5, 0.6 and 1   Weathering steel 0.6 and 1 mm							
DESIGN	DIMENSIONS IN mm				OPEN AREA	NUMBER OF PERFORATIONS m <sup>2</sup>	
	A	B	Ø	<			
	27	6	15	45°	20%	#1,152	
DIST. BETWEEN LONGITUDINAL PERFORATIONS	DIST. BETWEEN TRANSVERSAL PERFORATIONS	DIAMETER OF THE PERFORATION	ANGLE OF THE PERFORATION	DIRECTION OF THE PERFORATION IN RELATION TO THE LOCK			



114 Available for material and thickness: Zinc-aluminum 1.5 mm							
DESIGN	DIMENSIONS IN mm				50% OPEN AREA	NUMBER OF PERFORATIONS m <sup>2</sup>	
	A	B	Ø	<			
	1,3	2,77	8 <sup>+0,05</sup>	60°	↑	#9,951	
DIST. BETWEEN LONGITUDINAL PERFORATIONS	DIST. BETWEEN TRANSVERSAL PERFORATIONS	DIAMETER OF THE PERFORATION	ANGLE OF THE PERFORATION	DIRECTION OF THE PERFORATION IN RELATION TO THE LOCK			

115 Available for material and thickness: Aluminum 1.5 mm							
DESIGN	DIMENSIONS IN mm				20% OPEN AREA	NUMBER OF PERFORATIONS m <sup>2</sup>	
	A	B	Ø	<			
	4,2	5,65	5 <sup>+0,05</sup>	60°	↑	#10,246	
DIST. BETWEEN LONGITUDINAL PERFORATIONS	DIST. BETWEEN TRANSVERSAL PERFORATIONS	DIAMETER OF THE PERFORATION	ANGLE OF THE PERFORATION	DIRECTION OF THE PERFORATION IN RELATION TO THE LOCK			

116 Available for material and thickness: Aluminum 1.5 mm							
DESIGN	DIMENSIONS IN mm				30% OPEN AREA	NUMBER OF PERFORATIONS m <sup>2</sup>	
	A	B	Ø	<			
	2,5	3,7	5 <sup>+0,05</sup>	60°	↑	#15,180	
DIST. BETWEEN LONGITUDINAL PERFORATIONS	DIST. BETWEEN TRANSVERSAL PERFORATIONS	DIAMETER OF THE PERFORATION	ANGLE OF THE PERFORATION	DIRECTION OF THE PERFORATION IN RELATION TO THE LOCK			

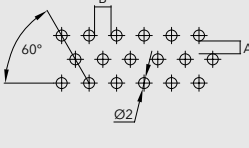
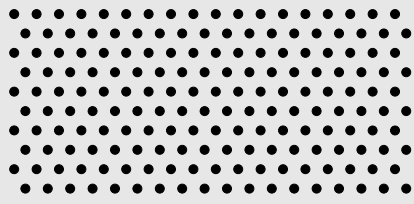
117 Available for material and thickness: Only 300 C 0.7 mm							
DESIGN	DIMENSIONS IN mm				23% OPEN AREA	NUMBER OF PERFORATIONS m <sup>2</sup>	
	A	B	Ø	<			
	1,1	1,5	1,5	60°	↑	#128,398	
DIST. BETWEEN LONGITUDINAL PERFORATIONS	DIST. BETWEEN TRANSVERSAL PERFORATIONS	DIAMETER OF THE PERFORATION	ANGLE OF THE PERFORATION	DIRECTION OF THE PERFORATION IN RELATION TO THE LOCK			

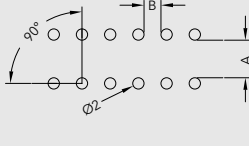
118 Available for material and thickness: Zinc-aluminum 0.5   Aluminum 0.7 mm							
DESIGN 	DIMENSIONS IN mm				15% OPEN AREA	NUMBER OF PERFORATIONS m <sup>2</sup>	
	A	B	Ø	<			
	2,3	3	2	60°		#46,200	
	DIST. BETWEEN LONGITUDINAL PERFORATIONS	DIST. BETWEEN TRANSVERSAL PERFORATIONS	DIAMETER OF THE PERFORATION	ANGLE OF THE PERFORATION	DIRECTION OF THE PERFORATION IN RELATION TO THE LOCK		

118 M2 Available for material and thickness: Zinc-aluminum 0.5   Aluminum 0.7 mm							
DESIGN 	DIMENSIONS IN mm				7,3% OPEN AREA	NUMBER OF PERFORATIONS m <sup>2</sup>	
	A	B	Ø	<			
	6,6	3	2	90°		#23,316	
	DIST. BETWEEN LONGITUDINAL PERFORATIONS	DIST. BETWEEN TRANSVERSAL PERFORATIONS	DIAMETER OF THE PERFORATION	ANGLE OF THE PERFORATION	DIRECTION OF THE PERFORATION IN RELATION TO THE LOCK		

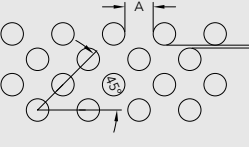
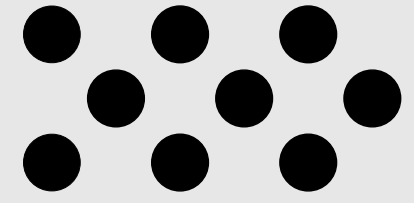
130 Available for material and thickness: Zinc-aluminum 1.5 mm							
DESIGN 	DIMENSIONS IN mm				30% OPEN AREA	NUMBER OF PERFORATIONS m <sup>2</sup>	
	A	B	Ø	<			
	12,6	1,3	10 <sup>±0.05</sup>	45°		#3,785	
	DIST. BETWEEN LONGITUDINAL PERFORATIONS	DIST. BETWEEN TRANSVERSAL PERFORATIONS	DIAMETER OF THE PERFORATION	ANGLE OF THE PERFORATION	DIRECTION OF THE PERFORATION IN RELATION TO THE LOCK		

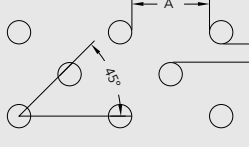
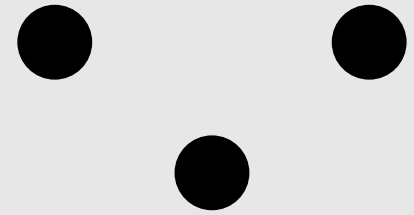
131 Available for material and thickness: Zinc-aluminum 1.5 mm							
DESIGN 	DIMENSIONS IN mm				10% OPEN AREA	NUMBER OF PERFORATIONS m <sup>2</sup>	
	A	B	Ø	<			
	50	12	15 <sup>±0.05</sup>	45°		#575	
	DIST. BETWEEN LONGITUDINAL PERFORATIONS	DIST. BETWEEN TRANSVERSAL PERFORATIONS	DIAMETER OF THE PERFORATION	ANGLE OF THE PERFORATION	DIRECTION OF THE PERFORATION IN RELATION TO THE LOCK		

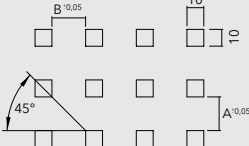
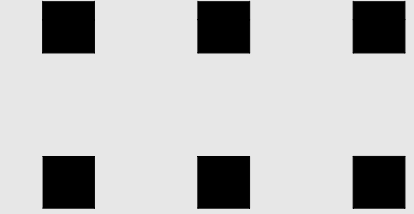
140 Available for material and thickness: Zinc-aluminum 0.5 and 0.6 mm							
DESIGN 	DIMENSIONS IN mm				11% OPEN AREA	NUMBER OF PERFORATIONS m <sup>2</sup>	
	A	B	AREA	<			
	20	20	100m <sup>2</sup>	45°		#1,156	
	DIST. BETWEEN LONGITUDINAL PERFORATIONS	DIST. BETWEEN TRANSVERSAL PERFORATIONS	DIAMETER OF THE PERFORATION	ANGLE OF THE PERFORATION	DIRECTION OF THE PERFORATION IN RELATION TO THE LOCK		

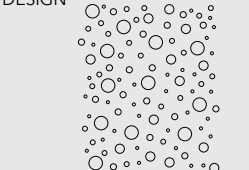
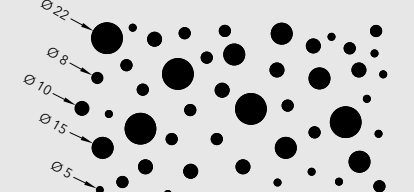
160 Available for material and thickness: Zinc-aluminum 1.5 mm						
DESIGN 	DIMENSIONS IN mm		OPEN AREA	NUMBER OF PERFORATIONS m <sup>2</sup>		
	Ø 5 Ø 8 Ø 10 Ø 15 Ø 22		18%	#1,477		
	DIST. BETWEEN LONGITUDINAL PERFORATIONS					

# PERFORATIONS

Solar Control | Finishes

## STANDARD PERFORATIONS

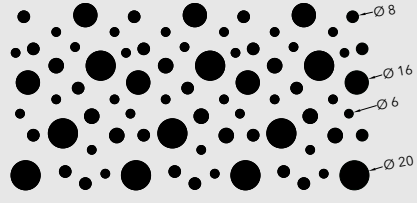
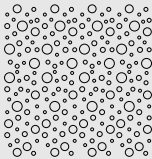
161 Available for material and thickness: Zinc-aluminum 1.5 mm							
DESIGN	DIMENSIONS IN mm				OPEN AREA	NUMBER OF PERFORATIONS m <sup>2</sup>	
	Ø 3	Ø 4	Ø 5	Ø 8			
					21%	#5,870	

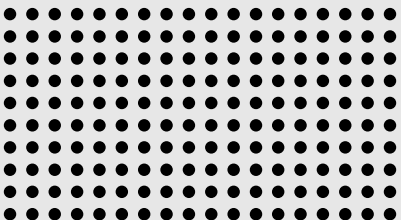
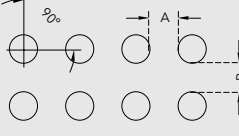
401 / D10							
DESIGN	DIMENSIONS IN mm				OPEN AREA	NUMBER OF PERFORATIONS m <sup>2</sup>	
	A	B	Ø	<			
	8	8	10	90°	24%	#3,086	
	DIST. BETWEEN LONGITUDINAL PERFORATIONS	DIST. BETWEEN TRANSVERSAL PERFORATIONS	DIAMETER OF THE PERFORATION	ANGLE OF PERFORATION			

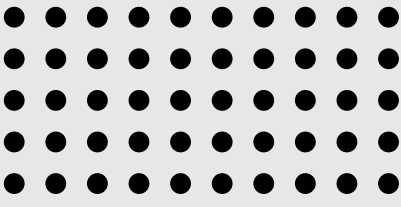
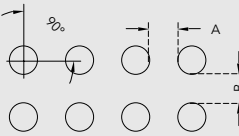
402 / D15							
DESIGN	DIMENSIONS IN mm				OPEN AREA	NUMBER OF PERFORATIONS m <sup>2</sup>	
	A	B	Ø	<			
	15	15	15	90°	20%	#1,111	
	DIST. BETWEEN LONGITUDINAL PERFORATIONS	DIST. BETWEEN TRANSVERSAL PERFORATIONS	DIAMETER OF THE PERFORATION	ANGLE OF PERFORATION			

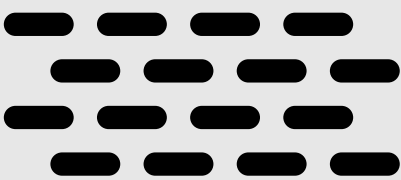
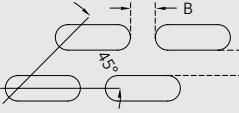
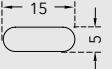
403 / OB15x15							
DESIGN	DIMENSIONS IN mm				OPEN AREA	NUMBER OF PERFORATIONS m <sup>2</sup>	
	A	B	DETALLE	<			
	5	5		45°	35%	#5,000	
	DIST. BETWEEN LONGITUDINAL PERFORATIONS	DIST. BETWEEN TRANSVERSAL PERFORATIONS		ANGLE OF PERFORATION			

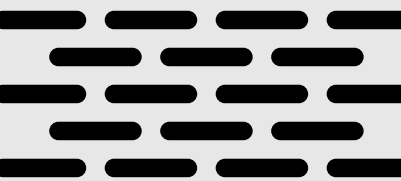
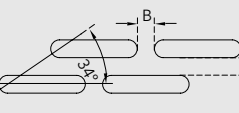
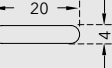
404 / OB20x4							
DESIGN	DIMENSIONS IN mm				OPEN AREA	NUMBER OF PERFORATIONS m <sup>2</sup>	
	A	B	DETALLE	<			
	4	4		34°	40%	#5,250	
	DIST. BETWEEN LONGITUDINAL PERFORATIONS	DIST. BETWEEN TRANSVERSAL PERFORATIONS		ANGLE OF PERFORATION			

405 / RE20x3		DIMENSIONS IN mm				OPEN AREA	NUMBER OF PERFORATIONS m <sup>2</sup>	
DESIGN	A	B	DETAIL	<				
	4	4		30°	36%	#5,952		
	DIST. BETWEEN LONGITUDINAL PERFORATIONS	DIST. BETWEEN TRANSVERSAL PERFORATIONS		ANGLE OF PERFORATION				

Note: Minimum margin of 10 mm. Available in aluminum, weathering steel, zinc-aluminum, galvanized steel and copper.

406 / RE5		DIMENSIONS IN mm				OPEN AREA	NUMBER OF PERFORATIONS m <sup>2</sup>	
DESIGN	A	B	DETAIL	<				
	5	5		90°	25%	#10,000		
	DIST. BETWEEN LONGITUDINAL PERFORATIONS	DIST. BETWEEN TRANSVERSAL PERFORATIONS		ANGLE OF PERFORATION				

407 / RE8		DIMENSIONS IN mm				OPEN AREA	NUMBER OF PERFORATIONS m <sup>2</sup>	
DESIGN	A	B	DETAIL	<				
	8	8		90°	25%	#3,906		
	DIST. BETWEEN LONGITUDINAL PERFORATIONS	DIST. BETWEEN TRANSVERSAL PERFORATIONS		ANGLE OF PERFORATION				



408 / RD22		DIMENSIONES EN mm				OPEN AREA	NUMBER OF PERFORATIONS m <sup>2</sup>	
DESIGN	A	B	DIMENSION	<				
	25	25		90°	11%	#289		
	DIST. BETWEEN LONGITUDINAL PERFORATIONS	DIST. BETWEEN TRANSVERSAL PERFORATIONS		ANGLE OF PERFORATION				

409 / D15		DIMENSIONS IN mm				OPEN AREA	NUMBER OF PERFORATIONS m <sup>2</sup>	
DESIGN	A	B	Ø	<				
	15	15	15	90°	20%	#1,109		
	DIST. BETWEEN LONGITUDINAL PERFORATIONS	DIST. BETWEEN TRANSVERSAL PERFORATIONS	DIAMETER OF THE PERFORATION	ANGLE OF PERFORATION				

# PERFORATIONS

Solar Control | Finishes

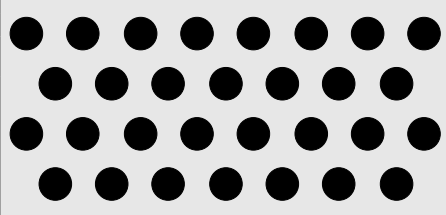
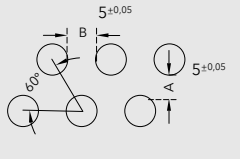
## STANDARD PERFORATIONS

410 / D5		DIMENSIONS IN mm				25% OPEN AREA	NUMBER OF PERFORATIONS m <sup>2</sup>	
DESIGN	A	B	Ø	<				
	3,23	4,25	5 <sup>+0,05</sup>	60°	DIRECTION OF THE PERFORATION IN RELATION TO THE LOCK 	#12810		
	DIST. BETWEEN LONGITUDINAL PERFORATIONS	DIST. BETWEEN TRANSVERSAL PERFORATIONS	DIAMETER OF THE PERFORATION	ANGLE OF PERFORATION				

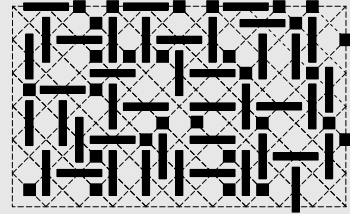
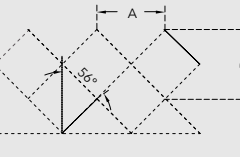
425		DIMENSIONS IN mm				OPEN AREA	NUMBER OF PERFORATIONS m <sup>2</sup>	
DESIGN	A	B	Ø	<				
	15	15	3	90°	ANGLE OF PERFORATION	24%	#5,374	
	DIST. BETWEEN LONGITUDINAL PERFORATIONS	DIST. BETWEEN TRANSVERSAL PERFORATIONS	DIAMETER OF THE PERFORATION	ANGLE OF PERFORATION				

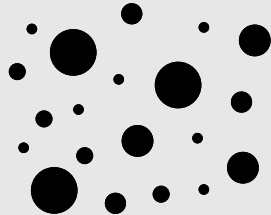
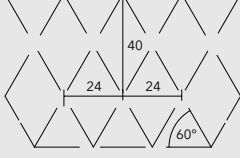
420		DIMENSIONS IN mm				OPEN AREA	NUMBER OF PERFORATIONS m <sup>2</sup>	
DESIGN	A	B	Ø	<				
	40	24	5/8/10/15/22	60°	ANGLE OF PERFORATION	16%	#1,185	
	DIST. BETWEEN LONGITUDINAL PERFORATIONS	DIST. BETWEEN TRANSVERSAL PERFORATIONS	DIAMETER OF THE PERFORATION	ANGLE OF PERFORATION				

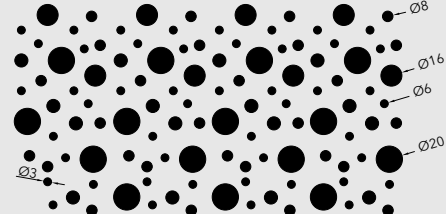
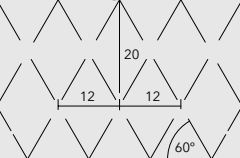
421		DIMENSIONS IN mm				OPEN AREA	NUMBER OF PERFORATIONS m <sup>2</sup>	
DESIGN	A	B	Ø	<				
	20	12	3/4/5/8/10	60°	ANGLE OF PERFORATION	16%	#5,471	
	DIST. BETWEEN LONGITUDINAL PERFORATIONS	DIST. BETWEEN TRANSVERSAL PERFORATIONS	DIAMETER OF THE PERFORATION	ANGLE OF PERFORATION				

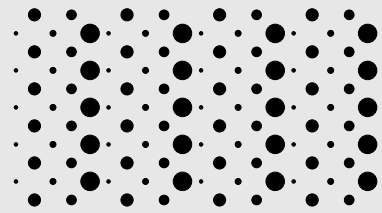
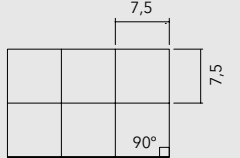
422		DIMENSIONS IN mm				OPEN AREA	NUMBER OF PERFORATIONS m <sup>2</sup>	
DESIGN	A	B	Ø	<				
	15	15	3/5/8/10/15	90°	ANGLE OF PERFORATION	14,4%	#2,211	
	DIST. BETWEEN LONGITUDINAL PERFORATIONS	DIST. BETWEEN TRANSVERSAL PERFORATIONS	DIAMETER OF THE PERFORATION	ANGLE OF PERFORATION				

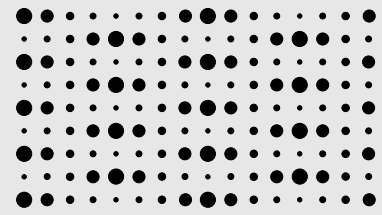
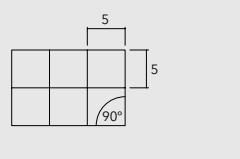
423		DIMENSIONS IN mm				OPEN AREA	NUMBER OF PERFORATIONS m <sup>2</sup>	
DESIGN	A	B	Ø	<				
	15	15	3/4/5/8/10	90°	ANGLE OF PERFORATION	13,9%	#4,422	
	DIST. BETWEEN LONGITUDINAL PERFORATIONS	DIST. BETWEEN TRANSVERSAL PERFORATIONS	DIAMETER OF THE PERFORATION	ANGLE OF PERFORATION				















Available in material and thickness: Zinc-aluminum 0.5 and 0.6 | Aluminum 0.7 and 0.8 | Weathering steel 0.6 and 1 mm



Available for material and thickness: Aluminum 1.5 mm

Available for materials and thicknesses: Zinc-aluminum 0.5 and 0.6 | Aluminum 0.7 and 0.8 | Weathering steel 0.6 and 1 mm

Available for materials and thicknesses: Zinc-aluminum 0.5 and 0.6 | Aluminum 0.7 and 0.8 | Weathering steel 0.6 and 1 mm

## SPECIAL PERFORATIONS (CNC)

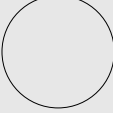
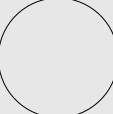
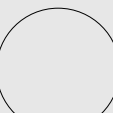
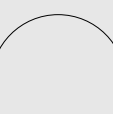
DRAWING	PUNCH TYPE	ACCEPTABLE THICKNESSES (mm)
	RD - 3 Ø 3 mm	0,5 - 0,75 - 1 - 1,5 - 2
	RD - 4 Ø 4 mm	0,5 - 0,75 - 0,8 - 1 - 1,5 - 1,9 - 2 - 3
	RD - 5 Ø 5 mm	0,5 - 0,75 - 1 - 1,25 - 1,5 - 1,9 - 2 - 2,5 - 2,25 - 3
	RD - 5,5 Ø 5,5 mm	1
	RD - 6 Ø 6 mm	2,25 - 3
	RD - 7 Ø 7 mm	1 - 2,25 - 0,75
	RD - 8 Ø 8 mm	0,5 - 0,75 - 1 - 1,5 - 2 - 3
	RD - 10 Ø 10 mm	0,5 - 0,75 - 1 - 1,25 - 1,5 - 1,75 - 1,9 - 2 - 2,5 - 3
	RD - 15 Ø 15 mm	0,5 - 0,75 - 1 - 1,25 - 1,5 - 1,75 - 1,9 - 2 - 2,25 - 2,5 - 3
	RD - 20 Ø 20 mm	0,5 - 0,75 - 1 - 1,25 - 1,50 - 1,9 - 2 - 2,5 - 3
	RD - 22 Ø 22 mm	0,5 - 0,75 - 1 - 1,25 - 1,5 - 1,9 - 2 - 2,5 - 3
	RD - 25 Ø 25 mm	0,5 - 0,75 - 1 - 1,5 - 2 - 3
	RD - 30 Ø 30 mm	0,5 - 1 - 1,25 - 2 - 2,5 - 3
	RD - 35 Ø 35 mm	1,2 - 2
	RD - 40 Ø 40 mm	0,8 - 1 - 3

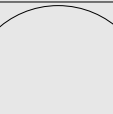
DRAWING	V	ACCEPTABLE THICKNESSES (mm)
	RD - 41 Ø 41 mm	1,5 - 2,25
	RD - 44 Ø 44 mm	0,5 - 0,75 - 1 - 1,5 - 2
	RD - 45 Ø 45 mm	2
	RD - 50 Ø 50 mm	1 - 2
	RD - 67 Ø 67 mm	0,75
	RD - 80 Ø 80 mm	1





Note: All materials can be perforated as long as they fall within the acceptable thickness.

# PERFORATIONS





















Solar Control | Finishes













## SPECIAL PERFORATIONS (CNC)

DRAWING	PUNCH TYPE	ACCEPTABLE THICKNESSES (mm)
	SQ - 5 5 mm	0,3 - 0,5 - 0,75 - 1 - 2 - 2,25 - 2,5 - 3
	SQ - 7 7 mm	3,5
	SQ - 8 8 mm	0,5 - 0,75 - 1 - 1,2 - 2
	SQ - 10 10 mm	0,5 - 0,75 - 1 - 1,2 - 2 - 2,5 - 3
	SQ - 10,5 10,5 mm	1 - 1,5
	SQ - 13 13 mm	1
	SQ - 15 15 mm	0,5 - 0,75 - 1 - 1,5 - 1,9 - 2 - 2,5 - 3
	SQ - 20 20 mm	0,5 - 0,75 - 1 - 1,2 - 3,5
	SQ - 25 25 mm	0,5 - 0,75 - 1 - 1,5 - 2
	SQ - 30 30 mm	0,5 - 0,75 - 1 - 1,5 - 2
	SQ - 40 40 mm	0,5 - 0,75 - 1 - 2
	SQ - 50 50 mm	2

DRAWING	PUNCH TYPE	ACCEPTABLE THICKNESSES (mm)
	HX - 8,7	1 - 2,5 - 3,5
	HX - 17,3	0,8
	HX - 34,6	0,8
	HX - 43,3	0,8
	HX - 69,3	0,8



DRAWING	PUNCH TYPE	ACCEPTABLE THICKNESSES (mm)
	RE - 12,5 x 10 12,5 x 10 mm	1
	RT - 13 x 5 13 x 5 mm	1
	RT - 13 x 10,5 13 x 10,5 mm	1
	RT - 15 x 5 15 x 5 mm	1
	RT - 15,5 x 5 15,5 x 5 mm	1
	RT - 15,5 x 13 15,5 x 13 mm	1
	RE - 15 x 10 15 x 10 mm	1
	RE - 18 x 5 18 x 5 mm	1
	RE - 20 x 3 20 x 3 mm	0,5 - 0,75 - 1 - 1,5 - 2 - 2,5 - 3
	RE - 20 x 5 20 x 5 mm	1
	RE - 20,5 x 5 20,5 x 5 mm	1
	RE - 20,5 x 10,5 20,5 x 10,5 mm	0,45
	RE - 23 x 8 23 x 8 mm	1
	RE - 25 x 5 25 x 5 mm	1
	RE - 26 x 5 26 x 5 mm	1
	RE - 25 x 8 25 x 8 mm	1
	RE - 30 x 4 30 x 4 mm	2,25
	RE - 50 x 3 50 x 3 mm	2 - 2,25
	RE - 59 x 3 59 x 3 mm	1
	RE - 80 x 3 80 x 3 mm	0,5 - 0,75 - 1 - 2 - 2,25 - 3,5

DRAWING	PUNCH TYPE	ACCEPTABLE THICKNESSES (mm)
	OB - 15 x 3 15 x 3 mm	0,5 - 0,75 - 1
	OB - 15 x 4 15 x 4 mm	0,5 - 0,75 - 1
	OB - 15 x 5 15 x 5 mm	0,5 - 0,75 - 1 - 1,5 - 2 - 3
	OB - 20 x 4 20 x 4 mm	0,5 - 0,75 - 1 - 1,5 - 2 - 2,5 - 3
	OB - 20 x 3 20 x 3 mm	0,5 - 0,75 - 1 - 2
	OB - 20 x 5 20 x 5 mm	0,65
	OB - 20 x 8 20 x 8 mm	0,5 - 0,75 - 1 - 2
	OB - 24 x 10 24 x 10 mm	0,5 - 0,75 - 1 - 2
	OB - 27 x 7 27 x 7 mm	2,5 - 3,5
	OB - 30 x 4 30 x 4 mm	1
	OB - 30 x 6 30 x 6 mm	1 - 2 - 3 - 3,5
	OB - 35 x 7 35 x 7 mm	0,6

Note: All materials can be perforated as long as they fall within the acceptable thickness.

# PERFORATIONS

Solar Control | Finishes

## THEMATIC PERFORATIONS

### THEMATIC PERFORATIONS

These products are created based on an image, silhouette or specific shape (based on the project requirement), configuring the perforations to generate a specific projection that is contrasted between the panels.

### VARIABLES

- Total surface area of the panels to be perforated
- Percentage of open area (total surface area of panels)
- Number of perforations per m<sup>2</sup>
- Definition of the image
- Contrasts
- Number of different punches

These are classified as:

- Single punch thematics
- Multiple punch thematics
- Cut thematics (water jet)

### Single punch thematics

These consist of the composition of flat figures such as silhouettes, numbers or letters using a single punch diameter.

### SINGLE PUNCH THEMATICS

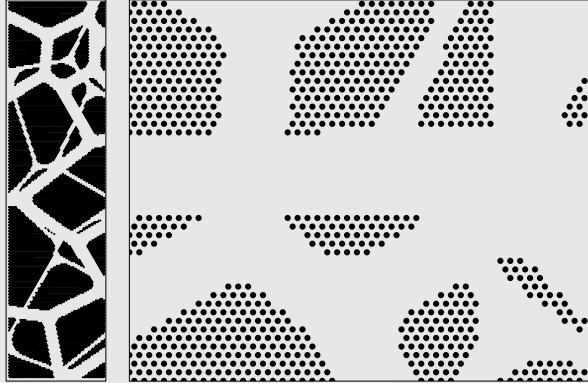

PANEL

PANEL SECTION

### Multi-punch thematics

These designs consist of the composition of figures through the random placement of punches of varying diameters. This generates various planes, light and shadow, greater contrast and better definition of the image.

### MULTI-PUNCH THEMATICS



PANEL

PANEL SECTION

### Cut thematics (water jet)

This type of perforation is achieved by making cuts for contour (cut longitude). It allows for very thick (up to 3 mm) and long panels or sheets to be used.

### CUT THEMATICS (water jet)

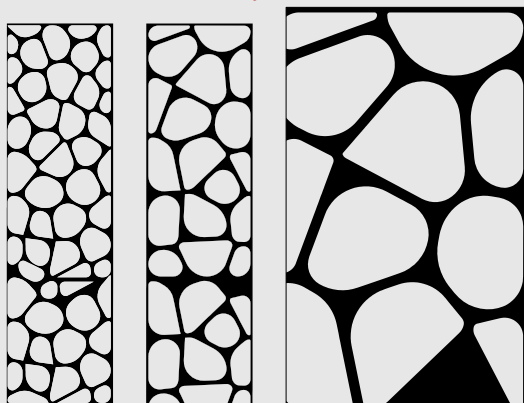

TYPE PANELS

PANEL SECTION

## SINGLE PUNCH THEMATICS

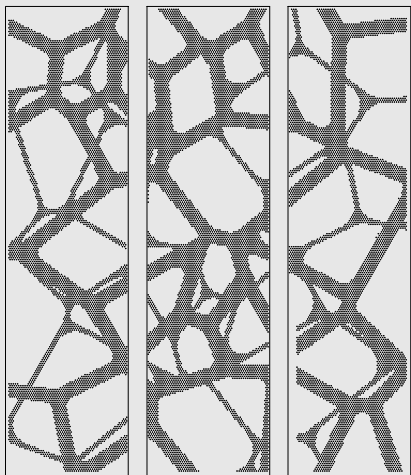

## MULTI-PUNCH THEMATICS

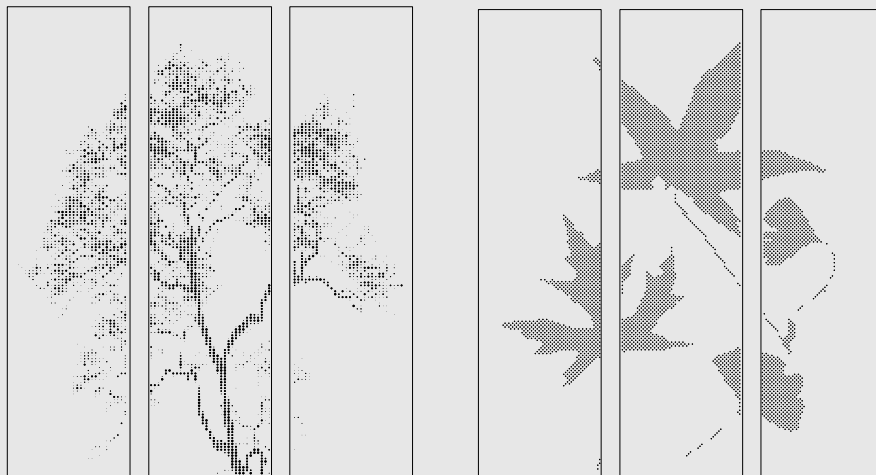

## SUPERIMPOSED DESIGNS

## SHEET A

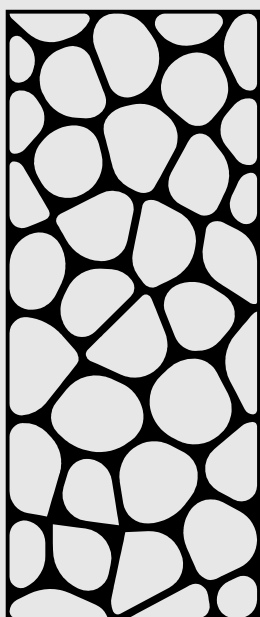

## SHEET B

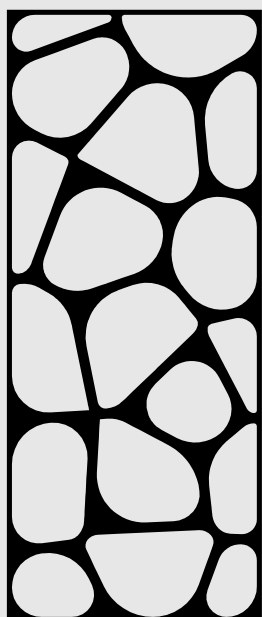

## SHEET C

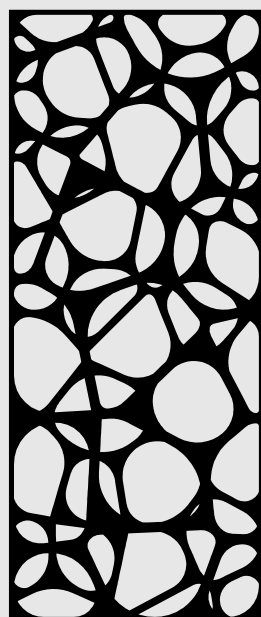

# PERFORATIONS

Solar Control | Finishes





# PERFORATIONS

Solar Control | Finishes

PRODUCT	103	106	109	140	110M1	110M3	111	112	113	114	115	116	118	118M2	130	131
<b>WOODEN SUNSCREENS</b>																
WOODBRISE 66 - 100																
<b>MOVEABLE SUNSCREENS</b>																
AEROSCREEN PLUS ALUMINUM					✓				✓						✓	✓
AEROSCREEN PLUS ZINC-ALUM.			✓													
AEROWING																
METALBRISE																
TERMOBRISE 150 - 335																
WINDSCREEN																
<b>LINEAR SUNSCREENS</b>																
AEROBRISE 100 - 200	✓	✓											✓	✓		
QUADROBRISE 25/50 - 25/75	✓	✓											✓	✓		
CELOSCREEN	✓	✓			✓								✓	✓		
SUNLINES	✓	✓											✓	✓		
30B - 50B - 50BD LOUVRE	✓	✓											✓	✓		
TUBRISE	✓	✓											✓	✓		
QUADROBRISE 32 X 32	✓	✓											✓	✓		
MINITUBRISE																
C LATTICES	✓	✓											✓	✓		
70S LATTICES	✓	✓											✓	✓		
84R - SL4 - H2 SUNSCREEN	✓	✓											✓	✓		
FLAT SUNSCREEN																
NBK TERRART BAGUETTE																
<b>MESHED SUNSCREENS</b>																
BRISOLCELL																
FILIGREE																
<b>PANELES SCREEN</b>																
STRIPWEAVE	✓	✓	✓	✓	✓	✓	✓	✓	✓	✓	✓	✓	✓	✓	✓	✓
STRIPSCREEN	✓	✓	✓	✓	✓	✓	✓	✓	✓	✓	✓	✓	✓	✓	✓	✓
C - G - J SCREENPANEL				✓	✓	✓	✓	✓	✓							
XL - XL W SCREENPANEL	No perforation available in this line, only punch drill															
SOFTWAVE 25 - 50	✓	✓			✓	✓		✓	✓				✓	✓	✓	✓
30 X 15 - 15 X 10 QUADROLINES	✓	✓			✓	✓		✓	✓				✓	✓	✓	✓
GKD SCREENS																
ALUSION																
<b>CURTAINS, SHUTTERS, AWNINGS</b>																
PRECIOUS METALS	Perforations used: 3%, 4%, 6% and 8%															

Note: The components of this product are constantly being improved and developed, so modifications may be made. The measurements listed on this Technical Sheet are expressed in millimeters (mm). In order to ensure that the product works correctly, the installation should always be handled by an authorized distributor using all of the accessories listed and in accordance with Hunter Douglas technical specifications.

PRODUCT	HUMIDITY RESISTANT*	MATERIALS								FINISHES				
		ZINC-ALUMINUM	ALUMINUM	WEATHERING STEEL	ZINC	COPPER	WOOD	FABRICS	100 COLORS	WOODGR.	MINERALGR.	ELECTRO POWDER*	6 COLORS	
<b>WOODEN SUNSCREENS</b>														
WOODBRISE 66 - 100	✓						✓							
<b>MOVEABLE SUNSCREENS</b>														
AEROSCREEN PLUS	✓	✓	✓	✓	✓	✓	✓		✓	✓	✓	✓		
AEROWING	✓		✓									✓		
METALBRISE	✓	✓	✓						✓	✓	✓	✓		
TERMOBRISE 150 - 335	✓	✓	✓	✓	✓	✓			✓	✓	✓			
WINDSCREEN	✓	✓	✓	✓		✓			✓	✓	✓	✓		
<b>LINEAR SUNSCREENS</b>														
AEROBRISE	✓	✓	✓	✓	✓	✓			✓	✓	✓	✓		
QUADROBRISE 25/50 - 25/75	✓	✓	✓	✓	✓	✓			✓	✓	✓			
CELOSCREEN	✓	✓	✓	✓	✓	✓			✓	✓	✓	✓		
SUNLINES	✓	✓	✓	✓	✓	✓			✓	✓	✓	✓		
30B - 50B - 50BD LOUVRE	✓	✓	✓	✓	✓	✓			✓	✓	✓	✓		
TUBRISE	✓	✓	✓		✓	✓			✓	✓	✓	✓		
QUADROBRISE 32 X 32	✓	✓	✓	✓	✓	✓			✓	✓	✓	✓		
MINITUBRISE	✓	✓	✓			✓			✓	✓	✓	✓		
C LATTICES	✓	✓	✓	✓	✓	✓			✓	✓	✓	✓		
70S LATTICES	✓	✓	✓	✓	✓	✓			✓	✓	✓	✓		
84R - SL4 - H2 SUNSCREEN	✓	✓	✓		✓	✓			✓	✓	✓	✓		
FLAT SUNSCREEN	✓	✓	✓	✓	✓	✓			✓	✓	✓			
NBK - TERRART BAGUETTE	✓													
<b>MESHED SUNSCREENS</b>														
BRISOLCELL	✓	✓	✓	✓	✓	✓			✓	✓	✓	✓		
FILIGREE	✓	✓	✓	✓	✓	✓			✓	✓	✓	✓		
<b>SCREEN PANELS</b>														
STRIPWEAVE	✓	✓	✓	✓	✓	✓			✓	✓	✓	✓		
STRIPSCREEN	✓	✓		✓		✓			✓	✓	✓	✓		
SCREENPANEL	✓	✓	✓	✓	✓	✓			✓	✓	✓	✓		
C - G - J SCREENPANEL	✓	✓	✓	✓		✓			✓	✓	✓	✓		
XL - XL W SCREENPANEL	✓	✓	✓	✓		✓			✓			✓		
SOFTWAVE 25 - 50	✓	✓	✓	✓	✓	✓			✓	✓	✓	✓		
30 X 15 - 15 X 10 QUADROLINES	✓	✓	✓	✓	✓	✓			✓	✓	✓	✓		
GKD SCREENS	✓	✓	✓	✓		✓			✓	✓	✓	✓		
ALUSION	✓		✓									✓		
<b>FOLDING &amp; SLIDING SHUTTERS</b>														
FOLDING & SLIDING SHUTTERS	✓	✓	✓		✓		✓	✓		✓	✓	✓		
TEXSCREEN	✓							✓						
<b>CURTAINS, SHUTTERS, AWNINGS</b>														
80 MM ALUMINUM EXTERIOR SHUTTER	✓		✓							✓			✓	
VERTICAL AWNINGS								✓						
PRECIOUS METALS	✓		✓											
QUANTUM ROLLER CURTAIN								✓						

\*Depending on inlayer selected (Metalbrise, Woodbrise, ScreenPanel and fabrics).





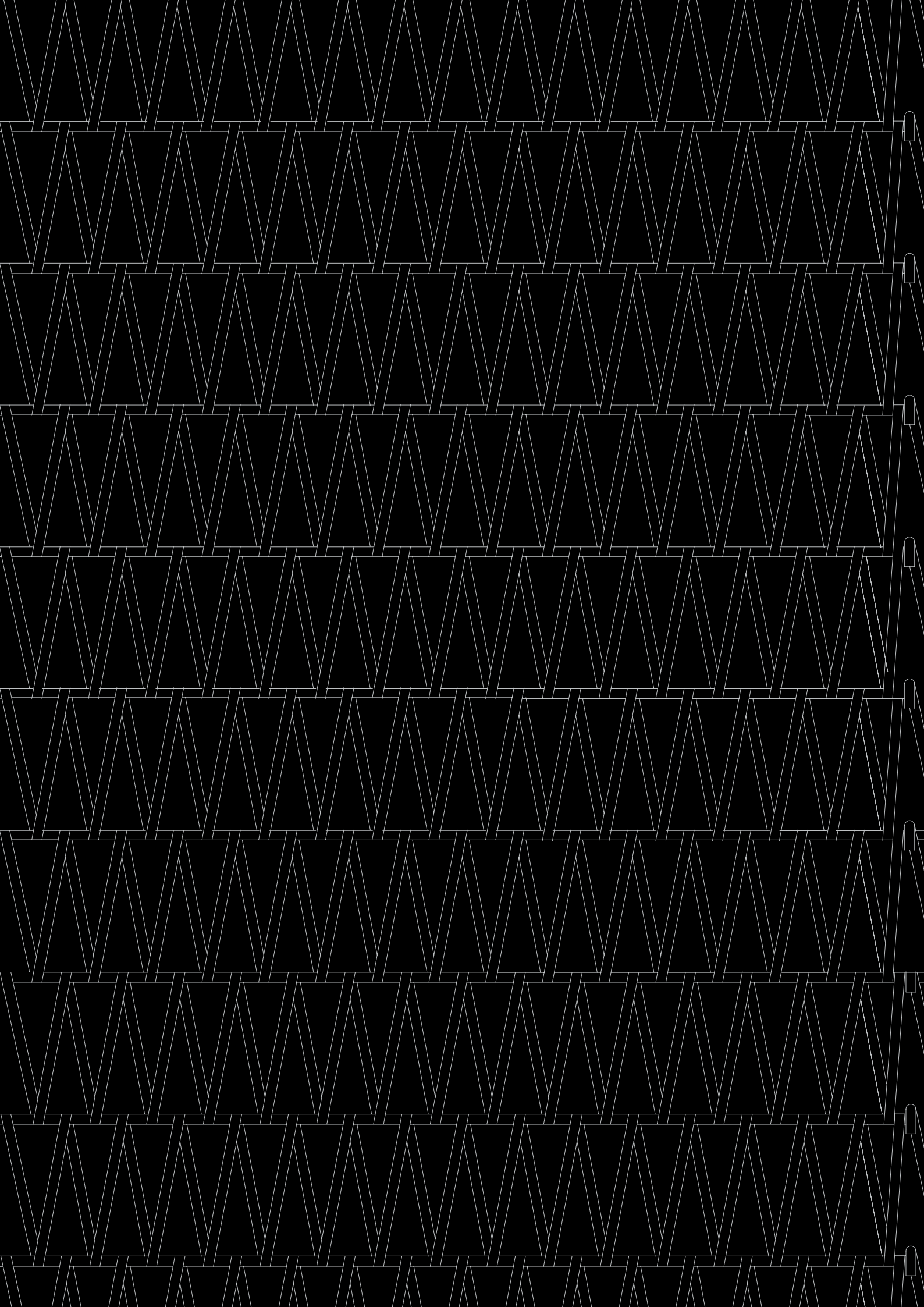

# HUNTER DOUGLAS PUBLICATIONS

## BOOKS



### LATAM: Latin American Contemporary Architecture

The Latam Books (LATAM 01 and LATAM 02) are a series of publications that bring together the work of Latin American architects with a selection of 50 projects from five countries in each volume. The editors decided to organize the cases by latitude, bringing together locations within the continent in a transversal manner and allowing the reader to compare and contrast diverse forms of architecture in an unusual way. While the projects belong to dissimilar cultural traditions, they share climatic-geographic variables that connect them.

## JOURNALS



MILÍMETRO is a Latin American magazine that includes works that stand out because of their architectural innovation and design. The privileged situation of Latin America today offers a great deal of potential for dissemination and research. The region has become a focus of cultural development which has generated very complex cultural processes that intersect at a time of redefinition. The journal Milímetro seeks to capture these situations and position topics of current interest, presenting new architectural experiences from the region.

- MM05/ Cultural Spaces
- MM04/ Sports Infrastructure
- MM03/ Office Architecture
- MM02/ Residential
- MM01/ Education



## TECHNICAL BOOKS



**SOLAR CONTROL:** Hunter Douglas gives architects the knowledge and skills necessary to integrate sun control systems into their project design work and to work together to improve the aesthetics of façades and provide highly effective protection.

**INTERIOR PRODUCTS:** Most people spend over 90% of their time indoors, which means that it is truly important to provide solutions that are an excellent alternative for your interior design projects.

## HUNTER DOUGLAS

Renato Rocha, President & CEO Latin American Operations  
Patricio Mardones, Product Division Director  
Architectural Products Latinamerica

### EXPORTS

Fernando Urizar, Export Manager for Architectural Products  
Karla Fuentes, Architect, Export Technical Support  
Carlos Mella, R&D Manager, USA Market Manager

## PUBLISHING CREDIT / CONSTRUCTO

General Editing and Artistic Direction  
Jeannette Plaut  
Marcelo Sarovic  
Design  
Isabel Sanhueza

The image features a background of vertical blinds in shades of blue, grey, and white. A yellow horizontal band is positioned across the middle of the image. The logo and company name are centered within this band.

**HunterDouglas**   
Architectural