



# **3** DEPARTMENT OF DEFENCE MAINTENANCE SUPPORT

Vendor No. 1216716



**PERTH**  
(08) 9459 8600  
**KALGOORLIE**  
(08) 9021 8300

**ADELAIDE**  
(08) 8231 1513  
**NEWMAN**  
(08) 9175 1164

**DARWIN**  
(08) 8963 5621  
**MT ISA**  
(07) 4743 6458

✉ [sales@bendtechgroup.com.au](mailto:sales@bendtechgroup.com.au)  
🌐 [bendtechdefence.com.au](http://bendtechdefence.com.au)

2-10 Kewdale Road, Welshpool WA 6106



**DEPARTMENT OF DEFENCE MAINTENANCE SUPPORT  
INDEX**

<b>DESIGN, ENGINEERING AND FABRICATION</b>	<b>///</b>	<b>2</b>
<b>CDEC PROCESS</b>	<b>///</b>	<b>3</b>
<b>WORKSHOP EQUIPMENT</b>	<b>///</b>	<b>5 - 11</b>
<b>WASHDOWN RAMP</b>	<b>///</b>	<b>12</b>
<b>WORKSHOP TOOLBOXES</b>	<b>///</b>	<b>14 - 16</b>
<b>WORKSHOP WORK STATION</b>	<b>///</b>	<b>17</b>
<b>GENERAL PURPOSE PLATFORMS</b>	<b>///</b>	<b>19 - 21</b>
<b>AVIATION PLATFORMS</b>	<b>///</b>	<b>23 - 26</b>
<b>BOLLARDS</b>	<b>///</b>	<b>28 - 29</b>
<b>PERSONNEL GATES</b>	<b>///</b>	<b>31 - 34</b>
<b>VEHICLE GATES</b>	<b>///</b>	<b>36 - 37</b>
<b>SITE HANDRAILS</b>	<b>///</b>	<b>39</b>
<b>BARRIERS</b>	<b>///</b>	<b>41</b>
<b>GRATING AND FENCING</b>	<b>///</b>	<b>43 - 35</b>
<b>ADJUSTABLE HEIGHT PLATFORMS</b>	<b>///</b>	<b>44</b>
<b>ENGINEERED OPTIMISATION</b>	<b>///</b>	<b>65 - 76</b>
<b>GIRAFFE SERIES</b>	<b>///</b>	<b>47 - 51</b>
<b>MONKEY MX21 SERIES</b>	<b>///</b>	<b>53 - 58</b>
<b>SQUIRREL SERIES</b>	<b>///</b>	<b>60 - 63</b>

## DESIGN, ENGINEERING AND FABRICATION

Although we have a comprehensive range of standard products which we have developed over an extended period of partnerships between planning, site personnel, management and ourselves. Most of these solutions started out as a specific problem which required us to develop a solution that enabled the actions required for operational efficiency.

### OUR APPROACH MEANS YOUR PROBLEMS ARE IN THE HANDS OF THOSE THAT SOLVE THEM.

**COMFORT** We take ownership of our role in operational efficiency with a system that provides a holistic solution.

**CERTAINTY** Being available, mobile and equipped to provide on-site consultations and scanning to ensure drawings, scopes of works and solutions are correct is invaluable.

**CONTROL** Design and engineering capabilities are crucial to providing certified and compliant solutions. We enable control over the situation.

**MOTION** Enabling processes and production to continue on-time is a crucial. We provide reliable, consistent pathways towards this goal.

**IMPACT** Solutions that are executed on-time consistently leaves an impact on the bottom line. Productivity receives a boost which is compounded by the benefits of the efficient use of resources which are freed up due to efficient solution development.

If you have a problem on-site, get in contact with the team and we will provide you with the certified salutation that you need.

“ **OUR TEAM PARTNERS WITH EACH OTHER INTERNALLY SO WE CAN PARTNER WITH YOU AND YOUR SUCCESS.** ”

# WE OFFER A FULL CONSULTING, 3D SCANNING AND ENGINEERING SERVICE

Projects and the associated challenges often require custom solutions, we take pride in our CDEC system. Consultation, Design, Engineering and Construction is our holistic approach to solution development making maintenance on-site safe, efficient and easy.

## CDEC PROCESS



**CONSULTATION** We come to you and visit your site to get a hands-on feel for your project. The aim of our consultation is to listen to and understand your requirements. If the project requires it, our 3D scanning capabilities will streamline measurement and data capture. This approach allows us to develop and discuss with you on-site, possible solutions to your problem, and the benefits we can offer.



**DESIGN** After the consultation we go back to our design team to begin the development of your custom solution. Our team produce designs in CAD Design complete with all drafting documentation ensuring an advanced manufacturing process. Our process allows and encourages you to be involved in the design stage and collaborate with our highly skilled team.



**ENGINEERING** Once the design is approved, we begin the development and engineering process. This ensures that the right material is used for your project to guarantee structural and functional integrity. We provide full certification that includes WLL, load ratings, integrity reports as well as certificate plates and identifications. We design and engineer all our solutions to ensure full compliance to ensure full compliance with Australian standards.



**CONSTRUCTION** Finally, once the project is ready and certified for construction, we manufacture your solution. We test, machine, fabricate and surface treat as well as trial fit your custom project. We only manufacture high quality products that provide long lasting, safe and efficient solutions.



# WORKSHOP EQUIPMENT

## WORKSHOP EQUIPMENT

### 2 TONNE WORKBENCH 900MM (H)

Part No. 5500766

#### CONSTRUCTION

- Heavy-duty steel
- Heavy-duty mine spec construction
- Fully certified to 2 Tonne SWL
- Height: 900mm



### WORKSHOP WHITEBOARD BENCH

Part No. 5001812

#### CONSTRUCTION

- Heavy-duty mine spec construction
- Heavy-duty castors for workshop mobility
- Can be used for shutdowns or planned maintenance
- Length: 1480mm
- Height: 2000mm
- Width: 700mm



### MOBILE FLAME CUTTING TABLE

Part No. 5501032

#### CONSTRUCTION

- Heavy-duty steel
- Engineered and Certified to SWL 1 Tonne
- Easy to empty slag bin and safer slag collection
- Replaceable support bars
- Heavy-duty lockable wheels
- Length: 1200mm
- Height: 900mm
- Width: 1200mm



## WORKSHOP EQUIPMENT

### HEAVY-DUTY PLATE CUTTING TABLE

Part No. 5501163

#### CONSTRUCTION

- Heavy-duty steel
- Length: 2830mm
- Height: 1000mm
- Engineered and Certified to SWL 3 Tonne
- Easy to empty slag bin and safer slag collection
- Replaceable support bars
- Heavy-duty lockable wheels



### 2 TONNE TRESTLE STAND 1000MM (L) X 900MM (H)

Part No. 5001747

#### CONSTRUCTION

- Heavy-duty steel
- Length: 1000mm
- Height: 900mm
- Width: 660mm
- Replaceable top section
- Fully engineered and certified
- Heavy-duty steel construction
- Stocked off-the-shelf, available for immediate delivery



### 5 TONNE TRESTLE STAND 1000MM (L) X 900MM (H)

Part No. 5001805

#### CONSTRUCTION

- Heavy-duty steel
- Length: 1000mm
- Height: 900mm
- Width: 600mm
- Replaceable top section
- Fully engineered and certified
- Heavy-duty steel construction
- Stocked off-the-shelf, available for immediate delivery



## WORKSHOP EQUIPMENT

### 5 TONNE TRESTLE STAND 2400MM (L) X 900MM (H)

Part No. 5001760

#### CONSTRUCTION

- Heavy-duty steel
- Length: 2400mm
- Height: 900mm
- Width: 656mm
- Replaceable top section
- Fully engineered and certified
- Heavy-duty steel construction
- Stocked off-the-shelf, available for immediate delivery



### 10 TONNE TRESTLE STAND 2400MM (L) X 650MM (H)

Part No. 5001813

#### CONSTRUCTION

- Heavy-duty steel
- Length: 1000mm
- Height: 650mm
- Width: 515mm
- Replaceable top section
- Fully engineered and certified
- Heavy-duty steel construction
- Stocked off-the-shelf, available for immediate delivery



## WORKSHOP EQUIPMENT

### FREE STANDING STEEL STORAGE RACK

Part No. 5003285

#### CONSTRUCTION

- Heavy-duty steel
- Height: 2250mm
- Length: 6000mm
- 12 shelves (6 either side)
- SWL 4.8 Tonne Capacity or 400kg per shelf
- Lifting eyes for ease of transport
- Forklift friendly for loading your product
- Fully engineered and certified

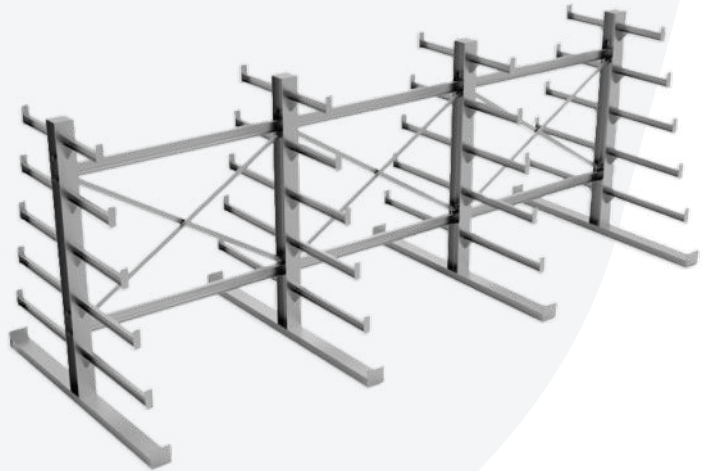

### HORIZONTAL STEEL PLATE STORAGE RACK

Part No. 5000220

#### CONSTRUCTION

- Heavy-duty steel
- Length: 2004mm
- Height: 3229mm
- Width: 8000mm
- Forklift friendly for plate loading
- Fully engineered and certified
- Modular design for ease of transport and erection on site
- SWL 6.5 Tonne per level (bottom level 10 Tonne)
- Cantilevered to ensure optimum space utilisation

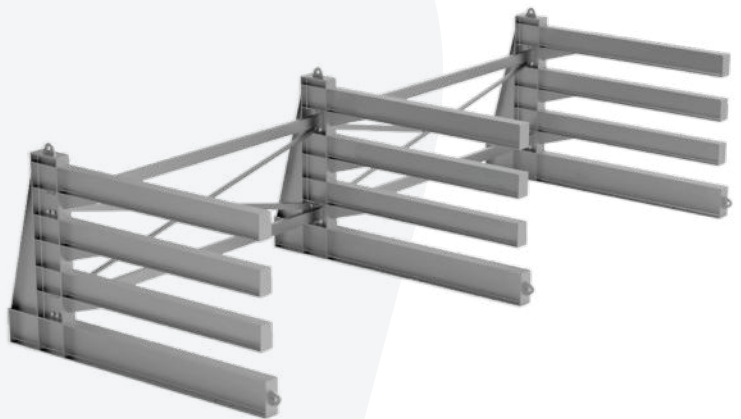

## WORKSHOP EQUIPMENT

### GENERAL PURPOSE STEEL RACK – LARGE

Part No.

6m – 5000222

7.5m – 5000221

9m – 5000219

#### CONSTRUCTION

- Heavy-duty steel
- SWL 3 Tonne per shelf
- 8 shelves (4 either side)
- Fully engineered and certified
- Lifting eyes for ease of transport
- Modular construction for ease of transport and erection on site
- Cantilevered to ensure optimum space utilisation

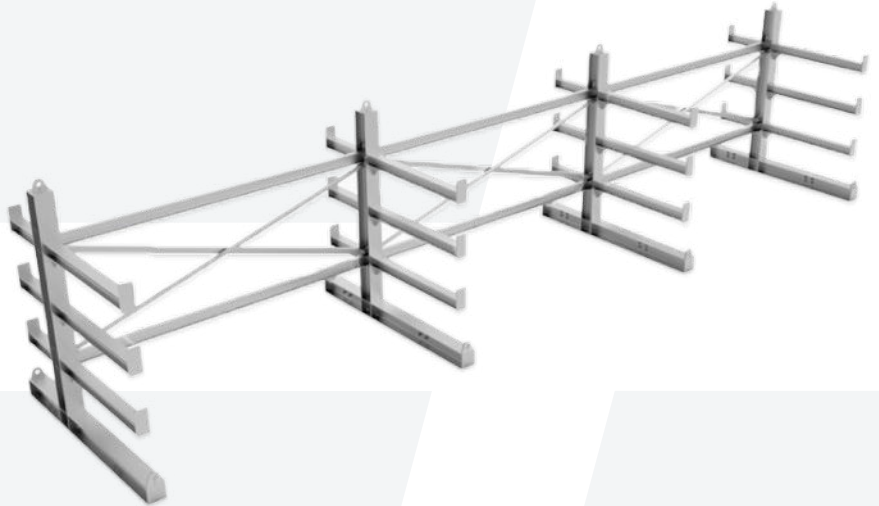

### GENERAL PURPOSE STEEL RACK – SMALL

Part No. 5501168

#### CONSTRUCTION

- Heavy-duty steel
- WLL: 3T per level
- Height: 2144mm
- Length: 2500mm
- Width: 1852mm
- 8 shelves (4 either side)
- Fully engineered and certified
- Lifting eyes for ease of transport
- Modular construction for ease of transport and erection on site
- Cantilevered to ensure optimum space utilisation

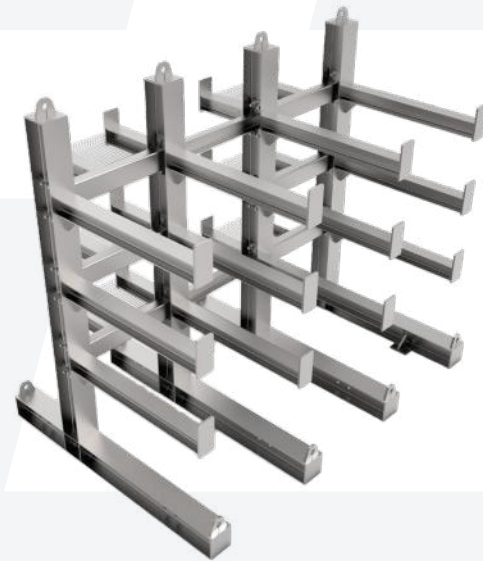

## WORKSHOP EQUIPMENT

### ELECTRICAL CABLE RACKING

Part No. 5502253

#### CONSTRUCTION

- Heavy-duty steel
- Certified and compliant with Australian Standards
- 600kg WLL Bottom Horizontal Bar
- 300kg WLL Top Horizontal Bar
- Finished in Y14 safety yellow

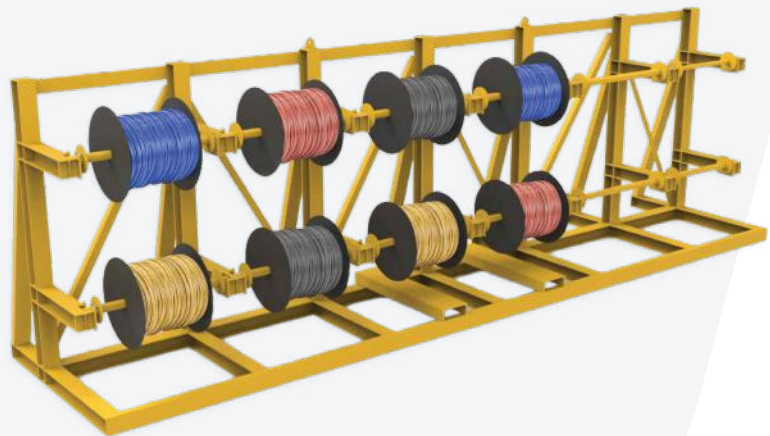

### VERTICAL STORAGE RACK, STEEL PLATE

Part No. 5500758

#### CONSTRUCTION

- Heavy-duty steel
- WLL: 8.5T per bay (51T total)
- Height: 2617mm
- Length: 8175mm
- Width: 2423mm
- Hot dip galvanised finish
- Modular construction for ease of transport and assembly on site
- Fully engineered and certified



### SLOPING VERTICAL STEEL PLATE RACK

Part No. 5501254

#### CONSTRUCTION

- Heavy-duty steel
- WLL: 4.25T per bay
- Height: 2617mm
- Length: 5747mm
- Width: 2865mm
- Modular design and Lifting eyes for ease of transport

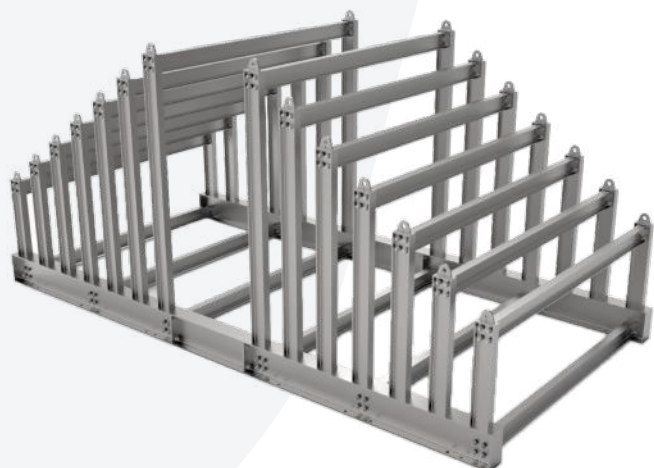

# WORKSHOP EQUIPMENT

## BELL 429 ROTOR BLADE WORKSHOP RACK

Part No. 5504171

### CONSTRUCTION

- Heavy-duty steel
- Height: 1500mm
- Length: 5000mm
- Certified and compliant to Australian Standards



## WASHDOWN RAMP

Designed and engineered for safe and efficient vehicle maintenance and cleaning. With a safe working load limit of 8 tonnes our washdown ramp can cater for anything from small four wheelers all the way up to light trucks.

- Can be fully customised to your vehicle requirements
- Certified and compliant to Australian Standards
- Reduced ramp angle to suit a wide range of wheelbases
- Marine grade galvanised to perform under the harshest conditions
- Heavy-duty steel construction
- Heavy-duty grating and angle iron for maximum grip
- Adjacent walkway for safely exiting the vehicle
- WLL of 8 tonnes
- Supplied complete with install guides and protocols

Part No. 5502605

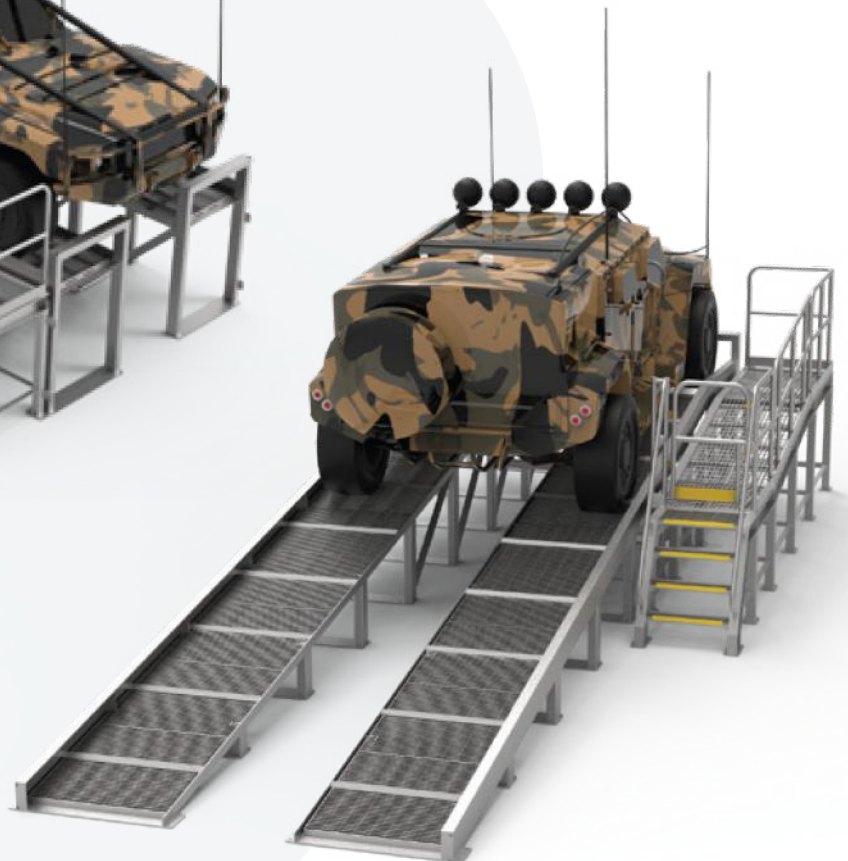

**B**

**B** **BIGGER  
THAN  
BUSINESS**

# WORKSHOP TOOLBOXES

 [www.bendtechdefence.com.au](http://www.bendtechdefence.com.au)

**B**

## WORKSHOP TOOLBOXES

We have created many specialised tool boxes for jobs on Mine sites that have specific tooling requirements. These toolboxes provide a lean and segregated approach to ensure that operators can confirm that they have all the Tooling needed prior to performing a job. and also during the job. Each tool is clearly in view and easy to access.

### Product Benefits

- High strength Steel Construction
- Gas Struts for lid
- Key Lock
- Heavy Duty hydrocarbon resistant foam cut out
- Each Tool has a Specifically CNC routed cutout
- Forklift slots to enable easy movement around site
- Can be painted to your specific company requirements
- Specific Signage and Stickers available on request
- Wheels can be added for ease of manoeuvrability on site
- These are made to suit your particular set of tools for each job, and can be certified and load rated to Australian Standards

“ **MAKING MAINTENANCE  
ON-SITE SAFE, EFFICIENT  
AND EASY** ”

# WORKSHOP TOOLBOXES

## SPECIALISED TOOL BOX 1295MM X 1200MM

Part No. 5500903

### CONSTRUCTION

- Heavy-duty steel
- Height: 500mm
- Gas Struts for lid
- Key Lock
- Heavy Duty hydrocarbon resistant foam cut out
- Each Tool has a Specifically CNC routed cutout



## SPECIALISED TOOL BOX 1550MM X 900MM

Part No. 5501068

### CONSTRUCTION

- Heavy-duty steel
- Height: 535mm
- Gas Struts for lid
- Key Lock
- Heavy Duty hydrocarbon resistant foam cut out
- Each Tool has a Specifically CNC routed cutout



## SPECIALISED TOOLBOX WITH DRAWER

Part No. 5501871

### CONSTRUCTION

- Heavy-duty steel
- Height: 730mm
- Width: 790mm
- Gas Struts for lid
- Heavy Duty hydrocarbon resistant foam cut out
- Each Tool has a Specifically CNC routed cutout



## WORKSHOP TOOLBOXES

### SPECIALISED TOOL BOX 1750MM X 900MM

Part No. 5500957

#### CONSTRUCTION

- Heavy-duty steel
- Height: 500mm
- Gas Struts for lid
- Key Lock
- Heavy Duty hydrocarbon resistant foam cut out
- Each Tool has a Specifically CNC routed cutout



### SPECIALISED FRONT ACCESS TOOLBOX

Part No. 5501946

#### CONSTRUCTION

- Heavy-duty steel
- Pins for tool positioning
- Labeled small parts bin with adjustable partitions
- Labeled double height bin with adjustable partitions



### TOOLBOX TROLLEY

Part No. 5501875

#### CONSTRUCTION

- Heavy-duty mine spec
- Length: 900mm
- Width: 945mm
- Height: 945mm
- Large industrial castors
- Lockable doors and drawers
- All drawers on heavy duty rollers
- Heavy duty top bench for component servicing



## WORKSHOP WORK STATION



### E-HUB EFFICIENCY WORK STATION MINI

Part No. 5500866

#### CONSTRUCTION

- Heavy-duty steel
- 25-inch screen included
- Small whiteboard on front
- Flip-up whiteboard at rear
- 3x heavy duty document clips
- Transportable with handles
- Adequate storage shelving
- Storage for Tags
- Robust pipe surrounds
- Powder-coated steel cabinet
- Dust proof cabinets and housing
- Large lockable castors
- Plug and play





# GENERAL PLATFORMS

# GENERAL PURPOSE PLATFORMS

## ACCESS PLATFORM 1200MM

Part No. 5412174

### CONSTRUCTION

- Heavy-duty aluminium
- Length: 1100mm
- Width: 1000mm
- Self-levelling jacks
- Self-closing gate
- Safety handrails
- Non-slip stairway and work area



## ACCESS PLATFORM 1400MM

Part No. 5401235

### CONSTRUCTION

- Heavy-duty aluminium
- Length: 2783mm
- Width: 900mm
- Self-levelling jacks
- Self-closing gate
- Safety handrails
- Non-slip stairway and work area



## ACCESS PLATFORM 1600MM

Part No. 5401183

### CONSTRUCTION

- Heavy-duty aluminium
- Length: 824mm
- Width: 780mm
- Self-closing gate
- Safety handrails
- Non-slip stairway and work area



## GENERAL PURPOSE PLATFORMS

### ACCESS PLATFORM 1900MM

Part No. 5412036

#### CONSTRUCTION

- Heavy-duty aluminium
- Length: 3903mm
- Width: 1000mm
- Self-levelling jacks
- Self-closing gate
- Safety handrails
- Non-slip stairway and work area



### ACCESS PLATFORM 1850MM

Part No. 5414025

#### CONSTRUCTION

- Heavy-duty aluminium
- Length: 2000mm
- Width: 1200mm
- Safety handrails
- Non-slip stairway and work area



### ACCESS PLATFORM 1700MM

Part No. 5414112

#### CONSTRUCTION

- Heavy-duty aluminium
- Length: 1200mm
- Width: 950mm
- Self-levelling jacks
- Self-closing gate
- Safety handrails
- Non-slip stairway and work area



# GENERAL PURPOSE PLATFORMS

## ACCESS PLATFORM 2200MM

Part No. 5412038

### CONSTRUCTION

- Heavy-duty aluminium
- Length: 4003mm
- Width: 1100mm
- Self-levelling jacks
- Self-closing gate and safety handrails
- Non-slip stairway and work area



## ACCESS PLATFORM 2500MM

Part No. 5401237

### CONSTRUCTION

- Heavy-duty aluminium
- Length: 4480mm
- Width: 1200mm
- Self-levelling jacks
- Self-closing gate and safety handrails
- Non-slip stairway and work area





# AVIATION PLATFORMS

## AVIATION PLATFORMS

### SIKORSKY S92 RH TAIL ACCESS PLATFORM

Part No. 5001970

A safe, certified and compliant access platform designed and engineered to access the tail of the Sikorsky S92 Helicopter.

#### CONSTRUCTION

- Full Tig welded Aluminium RHS
- Tread Plate Decking
- Gridmesh Stair Treads
- Self-closing gate
- D Rubber on edges
- Non slip yellow tread nosing on all treads
- SWL markings attached to platform



### SIKORSKY S92 LH TAIL ACCESS PLATFORM

Part No. 5501953

A safe, certified and compliant access platform designed and engineered to access the tail of the Sikorsky S92 Helicopter.

#### CONSTRUCTION

- Full Tig welded Aluminium RHS
- Tread Plate Decking
- Gridmesh Stair Treads
- Self-closing gate
- D Rubber on edges
- Non slip yellow tread nosing on all treads
- SWL markings attached to platform



## AVIATION PLATFORMS

### BELL 429 TAIL ROTOR INSPECTION PLATFORM

Part No. 5540170

A safe, certified and compliant access platform designed and engineered to access the tail rotor of the Bell 429 helicopter.

#### CONSTRUCTION

- Full Tig welded Aluminium RHS
- Tread Plate Decking
- Gridmesh Stair Treads
- Self-closing gate
- D Rubber on edges
- Non slip yellow tread nosing on all treads
- SWL markings attached to platform



## AVIATION PLATFORMS

### BELL 429 DOUBLE SIDED MX PLATFORM

Part No. 5504169

A safe, certified and compliant access platform designed and engineered to access the main rotor, engine and transmission of the Bell 429 helicopter.

#### CONSTRUCTION

- Full Tig welded Aluminium RHS
- Tread Plate Decking
- Gridmesh Stair Treads
- Self-closing gate
- D Rubber on edges
- Non slip yellow tread nosing on all treads
- SWL markings attached to platform



## AVIATION PLATFORMS

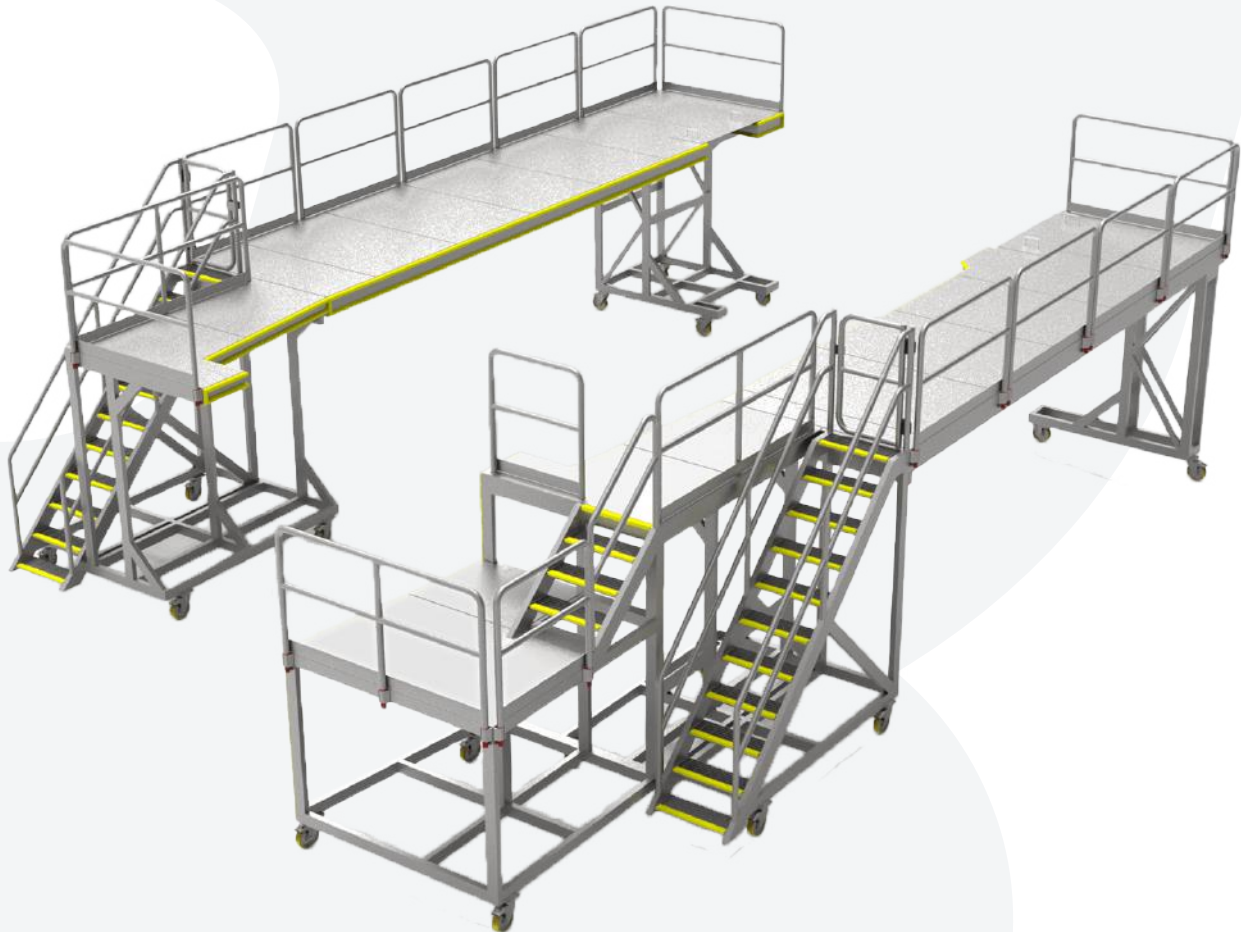

### **SIKORSKY S92 TOP FRAME ACCESS PLATFORM**

Part No. 5501798

Designed and engineered, safe and efficient Sikorsky S92 access platform. Certified and compliant with Australian Standards.

#### **CONSTRUCTION**

- Heavy-duty aluminium access platforms
- Certified and compliant with Australian Standards
- Fitted with heavy-duty castors
- Fitted with non-slip step nosing's
- Fitted with self-closing gates



**B** **BIGGER  
THAN  
BUSINESS**

# **BOLLARDS**

 [www.bendtechdefence.com.au](http://www.bendtechdefence.com.au)



# BOLLARDS



**BOLLARD 50NB 1200MM**  
Part No. 5501516



**BOLLARD 50NB 1200MM  
+ SIGN MOUNT**  
Part No. 55015162

Site bollards designed to aid in traffic and area management.

## CONSTRUCTION

- Heavy-duty steel
- Blasted and high-performance coated



**BOLLARD 65NB 1200MM**  
Part No. 5501332

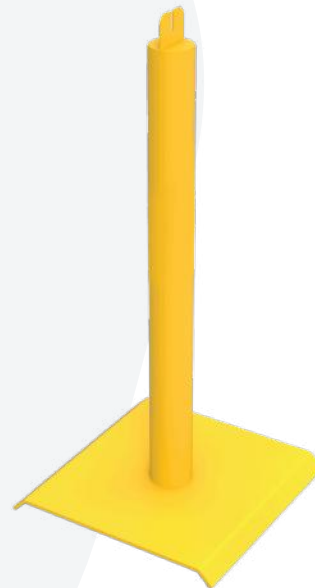

**BOLLARD 100NB 1200MM**  
Part No. 5501331

# BOLLARDS



**BOLLARD 1200MM**  
Part No. 5500919



**BOLLARD 1200MM  
SURFACE MOUNTED**  
Part No. 5501482

Site bollards designed to aid in traffic and area management.

**CONSTRUCTION**

- Heavy-duty steel
- Blasted and high-performance coated



**BOLLARD 1400MM**  
Part No. 5503236



**BOLLARD 1410MM**  
Part No. 5502963



# PERSONNEL GATES

## PERSONNEL GATES



**SELF-CLOSING GATE 850MM**  
Part No. 55007241



**SELF-CLOSING GATE 870MM**  
Part No. 55007242

Site and plant gates designed to aid in personnel and area management.

### CONSTRUCTION

- Heavy-duty steel
- Blasted and high-performance coated



**SELF-CLOSING GATE 960MM**  
Part No. 55007243



**SELF-CLOSING GATE 1000MM**  
Part No. 55007244

## PERSONNEL GATES



**SELF-CLOSING GATE 1050MM**  
Part No. 55007245



**SWING GATE 800MM**  
Part No. 5502994

Site and plant gates designed to aid in personnel and area management.

### CONSTRUCTION

- Heavy-duty steel
- Blasted and high-performance coated



**SWING GATE 820MM**  
Part No. 5502999



**SELF-CLOSING GATE  
WITH HANDRAIL**  
Part No. 5502640

## PERSONNEL GATES



**SELF-CLOSING GATE**  
**1000MM (H) X 650MM (W)**

Part No. 5503238



**SPRING LOADED GATE**  
**960MM (H) X 720MM (W)**

Part No. 5502838

Site and plant gates designed to aid in personnel and area management.

### CONSTRUCTION

- Heavy-duty steel
- Blasted and high-performance coated



**SELF-CLOSING GATE**  
**1020MM (H) X 1075MM (W)**

Part No. 5502638

“ **MAKING  
MAINTENANCE  
ON-SITE SAFE,  
EFFICIENT AND  
EASY** ”

## PERSONNEL GATES



**ROCK BREAKER GATE  
AND HANDRAIL 1000MM**

Part No. 5502995



**PRIMARY CRUSHER GATES**

Part No. 5503253

Site and plant gates designed to aid in personnel and area management.

### CONSTRUCTION

- Heavy-duty steel
- Blasted and high-performance coated



**MOBILE BARRICADE  
CART 1100MM**

Part No. 5503530

“ WE CAN  
CUSTOMISE  
ANY PRODUCT  
FOR YOUR SITE  
REQUIREMENTS ”

**B**

**B** **BIGGER  
THAN  
BUSINESS**

# VEHICLE GATES

 [www.bendtechdefence.com.au](http://www.bendtechdefence.com.au)

**B**

## VEHICLE GATES

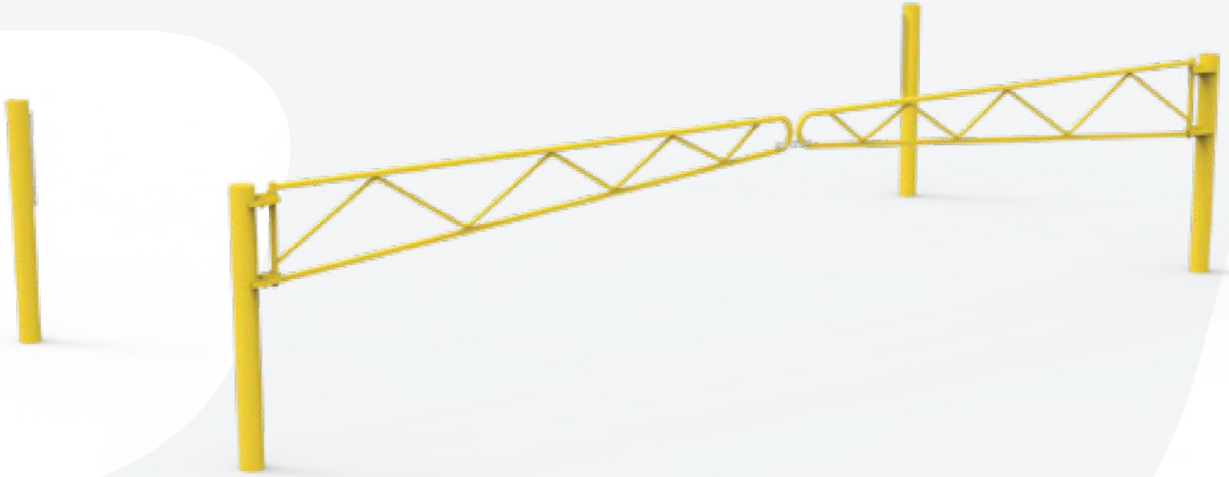

### **BOOM GATES**

Part No. 5501974

Site and plant gates designed to aid in personnel and area management. Our gates can be completely customised to suit your requirements.

#### **CONSTRUCTION**

- Heavy-duty steel
- Blasted and high-performance coated



### **ACCESS GATE 7000MM**

Part No. 5503264

# VEHICLE GATES



## **LOCKABLE GATE 2430MM**

Part No. 5503367

Site and plant gates designed to aid in personnel and area management. Our gates can be completely customised to suit your requirements.

### **CONSTRUCTION**

- Heavy-duty steel
- Blasted and high-performance coated

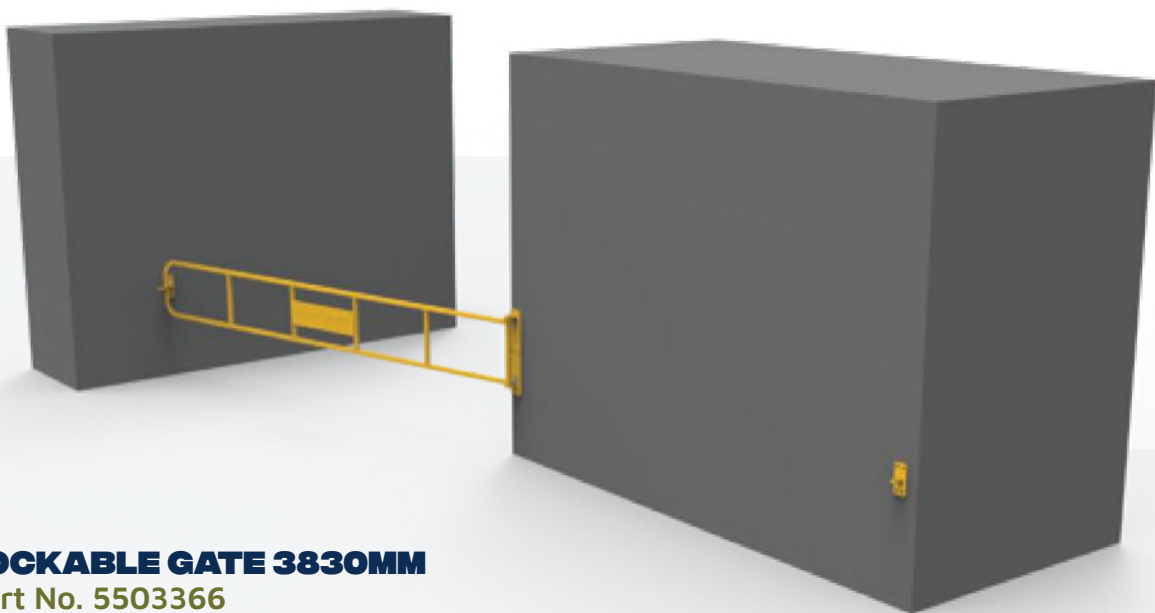

## **LOCKABLE GATE 3830MM**

Part No. 5503366



# SITE HANDRAILING

# SITE HANDRAILING

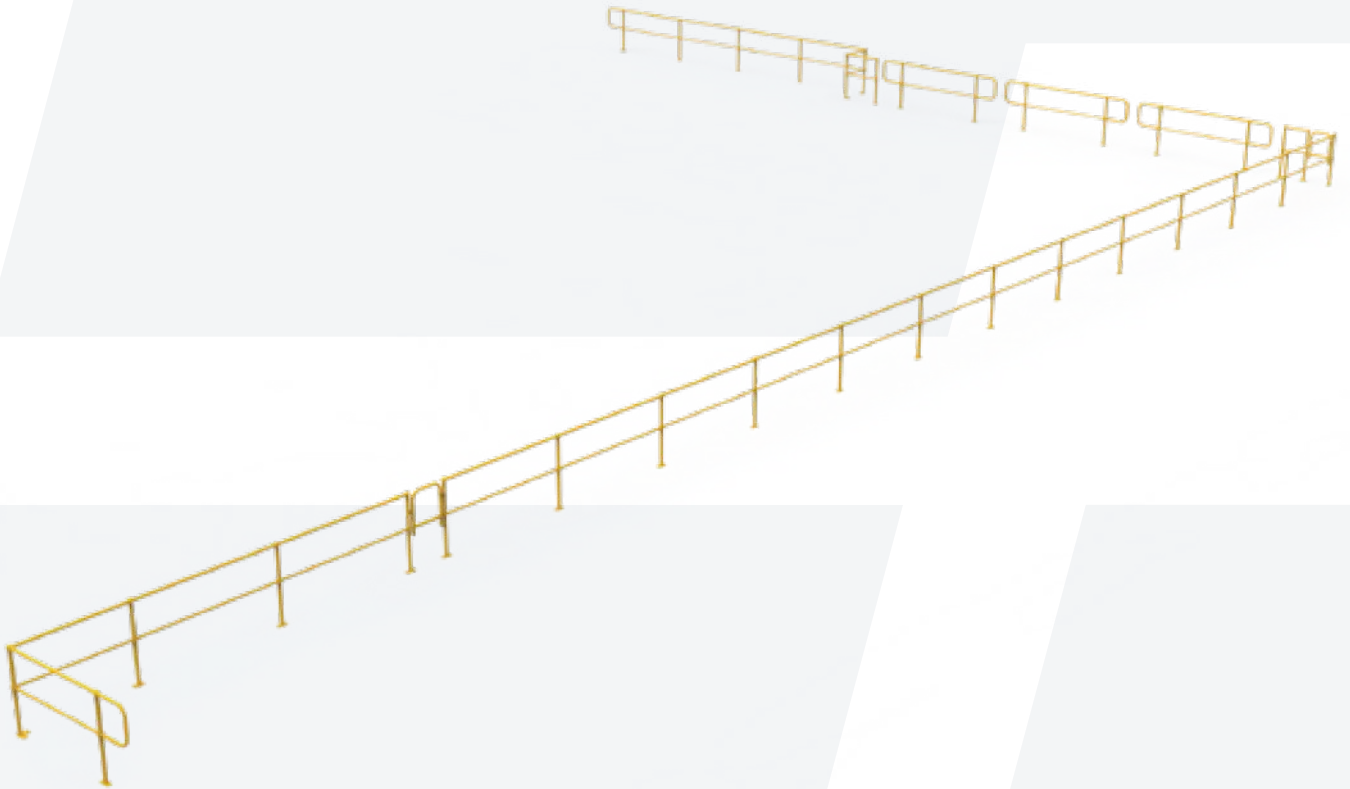

**SITE HANDRAILS**  
Part No. 5502863



**HANDRAIL AND SELF-CLOSING GATE 1000MM**  
Part No. 5502641



# BARRIERS

## BARRIERS

We supply all barrier and W-beam components and configurations. Either send us a list of parts and requirements or send us the details of the area you need to barricade.

### WE CAN SUPPLY ANY LENGTH OR AMOUNT OF:

- W-beam
- Bends
- Fixings
- Posts
- Nosing's
- Hardware
- Signage



“ WE CAN CUSTOMISE ANY PRODUCT FOR YOUR SITE REQUIREMENTS ”



# GRATING & FENCING

## GRATING AND FENCING

### FENCING

We supply all fencing and gate components and configurations. Either send us a list of parts and requirements or send us the details of the area you need to fence or enclose

### GRATING

We supply all grating components, patterns and finishes. You can send us your requirements or list of parts and we will supply you with everything you need.

### MATERIAL OPTIONS :

- Aluminium • Steel • Stainless steel 304 and 316

### FINISHING OPTIONS :

- Untreated • Galvanised (steel only) • Bitumen dipped (steel only)
- Electro-polished (stainless steel only) • Anodised • Powder coated
- Mill finish (aluminium or stainless steel only)

### WE CAN SUPPLY ANY LENGTH, SIZE OR AMOUNT OF:

- Rolls of fencing • Posts • Wire or barbed wire
- Gates • Hinges • Locks • Hardware

### PATTERN OPTIONS :

- Load Bar Pitch 30mm / Cross Rod Pitch 100mm
- Load Bar Pitch 30mm / Cross Rod Pitch 50mm
- Load Bar Pitch 40mm / Cross Rod Pitch 100mm
- Load Bar Pitch 40mm / Cross Rod Pitch 50mm
- Load Bar Pitch 60mm / Cross Rod Pitch 50mm

\*Serrated and plain bars available with any configuration or finish



# ADJUSTABLE HEIGHT PLATFORMS

Vendor No. 1216716



**3** | **BIGGER  
THAN  
BUSINESS**

**Giraffe  
G20**



**WLL 300kg/660 lbs  
www.equiptec.co**

# **EQUIPTEC GIRAFFE**

**Own The High Ground**

 [www.bendtechdefence.com.au](http://www.bendtechdefence.com.au)



# EQUIPTEC GIRAFFE BENEFITS



1 Prevent falls down the stair with the firm safety bar



2 3 Gate gives access to work surface off the end or either side



3 Reach over obstacles with generous 1.74m platform



4 Anti sway platform locks. Physical lock at every step height

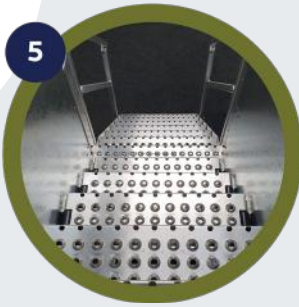

5 Climb or descend hands free. Spacious, easy gradient stairs



6 Efficient to climb with constant grade stair at any platform height



7 Safe and steady height adjustment with hydraulic safety valve + decent speed control



8 Easy to load and transport with forklift pockets in chassis





# EQUIPTEC GIRAFFE BENEFITS



Minimal floor footprint  
that remains the same  
for all platform heights



# GIRAFFE G20 HEIGHT RANGE

\*One base model reaching up to 4.7m



## GIRAFFE G20

Part No. 5800500

### CONSTRUCTION

- Deck height range: 1500mm – 2900mm
- Overall width: 1456mm
- Overall length: 4495mm
- Platform width: 780mm
- Platform length: 1786mm
- WLL: 300kg



## GIRAFFE G20 + 1 STEP

Part No. 5800502

### CONSTRUCTION

- Deck height range: 1800mm – 3100mm
- Overall width: 1456mm
- Overall length: 4750mm
- Platform width: 780mm
- Platform length: 1786mm
- WLL: 300kg



## GIRAFFE G20 + 2 STEP

Part No. 5800503

### CONSTRUCTION

- Deck height range: 2000mm – 3300mm
- Overall width: 1456mm
- Overall length: 4945mm
- Platform width: 780mm
- Platform length: 1786mm
- WLL: 300kg





## GIRAFFE G20 HEIGHT RANGE

\*One base model reaching up to 4.7m

### GIRAFFE G20 + 4 STEP

Part No. 5800504

#### CONSTRUCTION

- Deck height range: 2400mm – 3800mm
- Overall width: 1900mm
- Overall length: 5395mm
- Platform width: 780mm
- Platform length: 1786mm
- WLL: 300kg



### GIRAFFE G20 + 8 STEP

Part No. 5800505

#### CONSTRUCTION

- Deck height range: 3700mm – 4700mm
- Overall width: 2500mm
- Overall length: 7270mm
- Platform width: 780mm
- Platform length: 1786mm
- WLL: 300kg



“ **MAKING MAINTENANCE  
ON-SITE SAFE, EFFICIENT  
AND EASY** ”



# GIRAFFE OPTIONAL ACCESSORIES

The Giraffe G20 system includes many retrofittable accessories allowing you to configure a more exact solution for your access challenges.



## HAMMERHEAD DECK

Part No. 5800507

- With a capacity of 200kg WLL this deck not only gives more room, but also offers both side gates and individually removable front facing gates. That's great unobstructed access to the workface on one or both sides.



## SLIDE OUT DECK

Part No. 5800506

- The Slide Out Deck allows you to reach out up to 2.9m over an obstacle, even with a 150kg loading. It still features 3 exit gates as does the standard deck and rolls out effortlessly at any height.
- Once you are finished with it, simply slide it back in out of the way.



## ANGLED DECK

Part No. 5800508

- When you are faced with tight space the G20 Angled Deck will save you precious room.
- With a 150kg capacity it includes an end gate and the same pack components can be assembled either to the right hand or left hand sides.

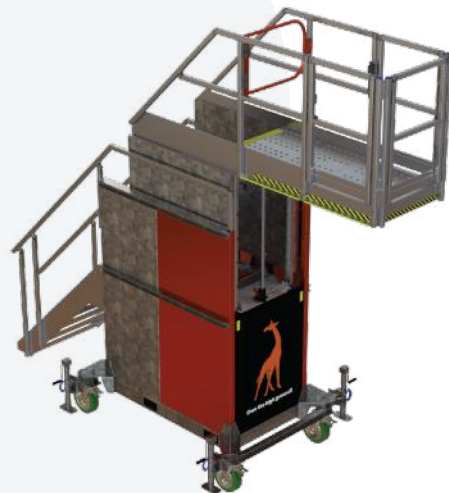

## ALL TERRAIN KIT

- Larger diameter, heavy duty, towable wheels along with Jack Stands at each corner allow units with this accessory added to operate off the hard stand.
- With a level bubble on each corner, its easy to get the unit level and firm even if the ground is uneven.





# GIRAFFE SERIES

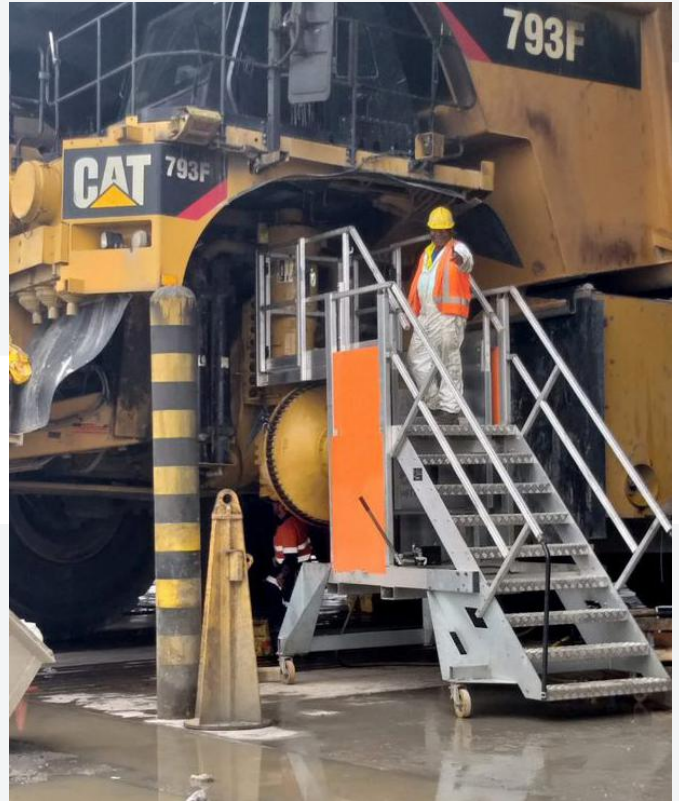



# MONKEY MX21



# MONKEY SERIES BENEFITS



1 Self closing, full size front gate



2 Convenient, solid rear gate, swings up or down



3 Generously sized work deck with a 250kg WLL, allowing for work gear



4 Extra sturdy stable work deck with tough oversize mast and roller system



5 Rapid spring assisted adjustment



6 Six height installments to fit multiple tasks



7 Spacious, easy and gradient stairs with non-slip yellow treads

## MONKEY SERIES BENEFITS

A solitary Monkey MX21 can replace multiple fixed height platforms.  
The Monkey can be used as both a work deck or an accessway.  
Efficient in use and efficient to store...here are a few more great Monkey benefits!

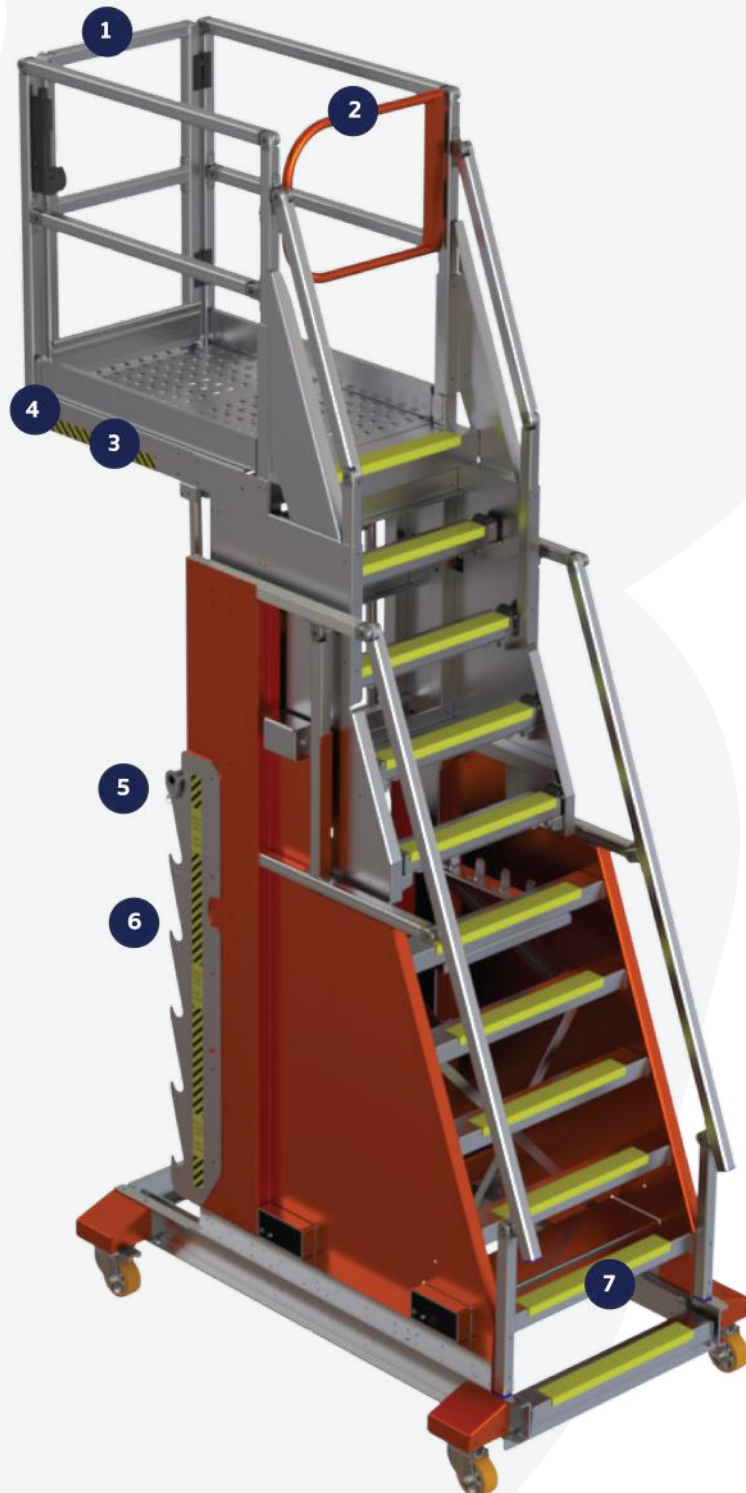

## MONKEY SERIES

# MX21 RANGE

The Monkey MX21 units have been tested and confirmed to meet or exceed the strength, stability and all other applicable requirements for the following standards:

- ANSI-ASC A14.7-2011 (USA) • CSA Z11-12 (Canada) • AS/NZS 1576.1 (Australia and New Zealand).
- \*On base model reaching up to 4.5 metres. Working load limit 250kg

### MONKEY MX21

Part No. 5600543

#### CONSTRUCTION

- Deck height range: 1500mm – 2750mm
- Overall width: 1177mm
- Overall length: 2242mm
- Platform width: 642mm
- Platform length: 1041mm



### MONKEY MX21 + 4 STEP SUB CHASSIS

Part No. 5600548

#### CONSTRUCTION

- Deck height range: 2500mm – 3750mm
- Overall width: 1177mm
- Overall length: 2684mm
- Platform width: 642mm
- Platform length: 1041mm



## MONKEY SERIES MX21 RANGE



### MONKEY MX21 + ALL TERRAIN

Part No. 5600547

#### CONSTRUCTION

- Deck height range: 1500mm – 2750mm
- Overall width: 1449mm
- Overall length: 2242mm
- Platform width: 642mm
- Platform length: 1041mm



### MONKEY MX21 + GO-BASE

Part No. 5600546

#### CONSTRUCTION

- Deck height range: 1500mm – 2750mm
- Overall width: 1177mm
- Overall length: 2242mm
- Platform width: 642mm
- Platform length: 1041mm



### MONKEY EXTENDED CANTILEVER

Part No. 5600549

#### CONSTRUCTION

- Deck height range: 1500mm – 2750mm
- Overall width: 1177mm
- Overall length: 2990mm
- Platform width: 749mm
- Platform length: 1788mm





# MONKEY SERIES



# MONKEY SERIES MX21 RANGE



## GO-BASE CHASSIS

Part No. 5600559

Heavy-duty lockable wheels promotes movement and storage efficiency.

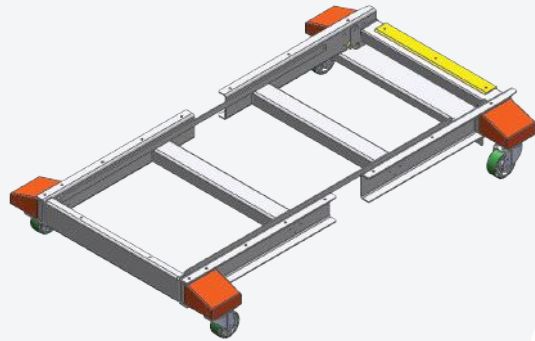

## ALL TERRAIN KIT

Part No. 5600547

This option is suitable for outdoor working requirements. Rubber wheels and independent, adjustable jack stands provide stability and ability to level the MX21 on undulating sites.

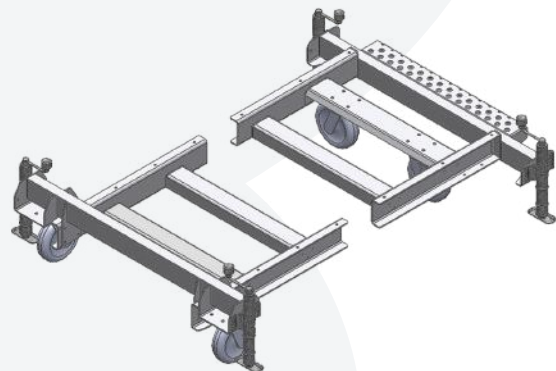

## HYDRAULIC KIT

Part No. 5600550

The smooth, double action hydraulic kit makes adjusting deck height easier and more efficient. Recommended with additional weight kits such as the Extended Cantilever.





**3** **BIGGER  
THAN  
BUSINESS**

# VRS SQUIRREL SERIES

 [www.bendtechdefence.com.au](http://www.bendtechdefence.com.au)



# VRS SQUIRREL BENEFITS

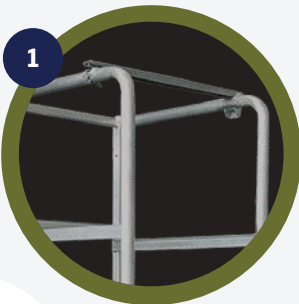

1 Safety bar at the rear of the platform stays out of the way for climbing on or off the deck and clips on easily behind the user



2 Easy pull trigger rod gives a positive lock at each of the four deck heights



3 Easy loading with strong 'tie-down' points

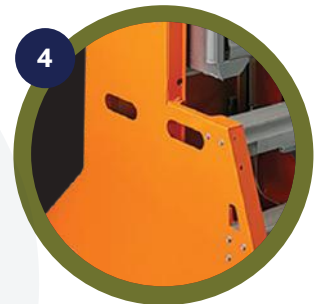

4 Quick to shift around the site with the integral carry handles.



5 Very Light and very strong thanks to the effective design and the predominantly aluminium structure.

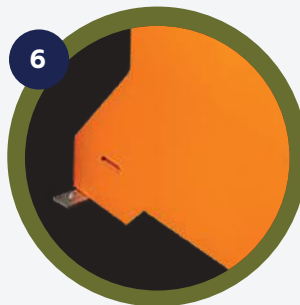

6 A unique 'flip feet' provide extra stability when the deck is in use, but flip conveniently out of the way when you need to get through a narrow gap.

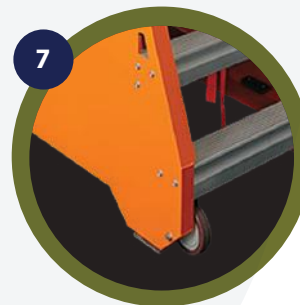

7 Simple to move just tilt until wheels engage and then push around



# VRS SQUIRREL BENEFITS



## VRS SQUIRREL SERIES

The VRS Squirrel Series brings the safety and efficiency of the VRS platform series, right down to the smaller tasks in building and maintenance in many industries. It has excellent manoeuvrability and is fully height adjustable, which has made it the platform of choice for tradesmen on building sites, right through to maintenance workers in oil refineries.



### VRSQ-14

Part No. 5800194

#### CONSTRUCTION

- Deck height range: 720mm – 1440mm
- Overall width (flap feet out): 776mm
- Overall width (flap feet in): 644mm
- Overall length: 1090mm
- Platform width: 510mm
- Platform length: 565mm

### VRSQ-17 (WITH GO BASE)

Part No. 5800510

#### CONSTRUCTION

- Deck height range: 950mm – 1600mm
- Overall width: 1050mm
- Overall length: 1200mm
- Platform width: 510mm
- Platform length: 565mm

# VRSQ-14 AND VRSQ-17 HEIGHT ADJUSTABLE PLATFORMS

4 Deck Positions

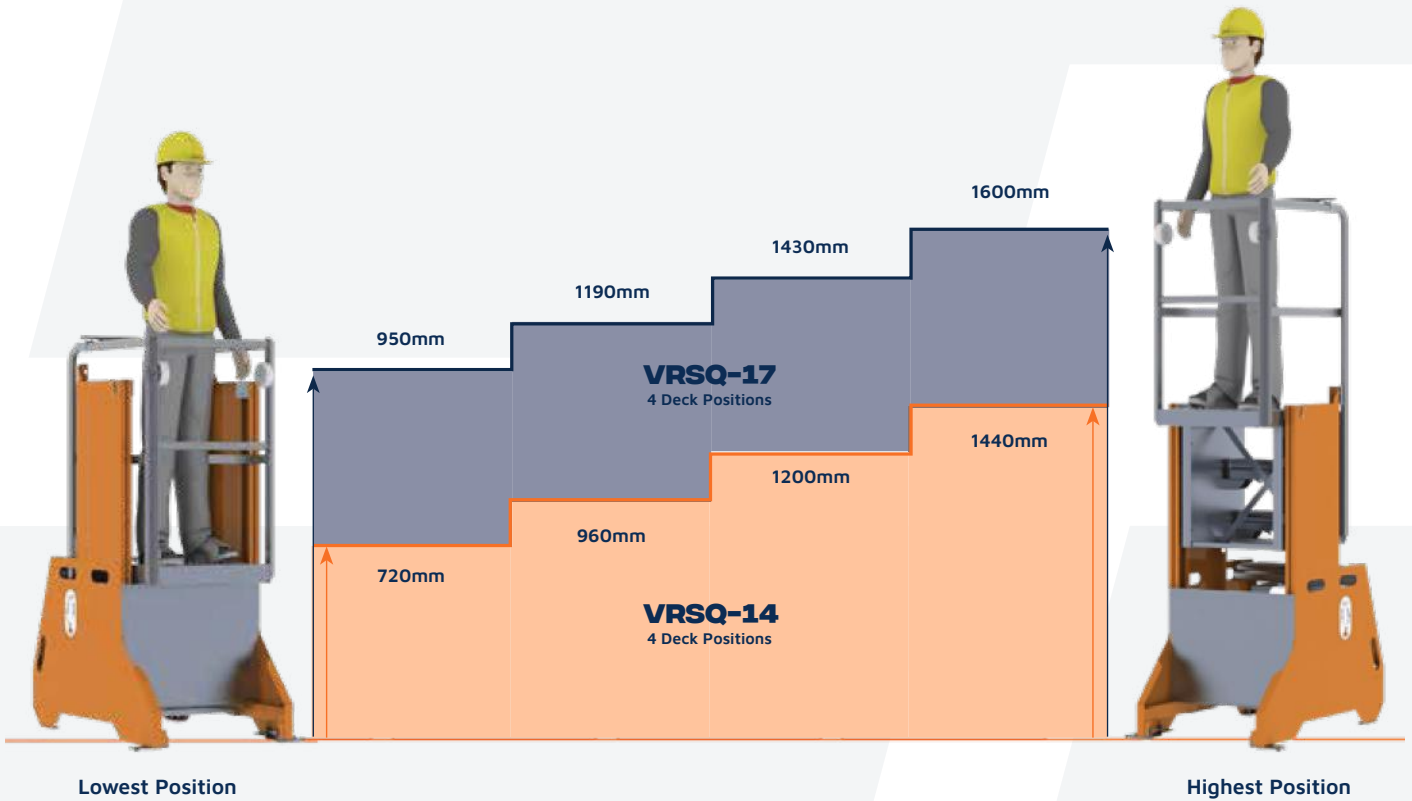

Lowest Position

Highest Position



“ SAFE,  
EFFICIENT  
ACCESS  
AT ALL  
LEVELS ”





# **ENGINEERED OPTIMISATION:**

WEIGHT REDUCTION, SPATIAL ECONOMY AND ERGONOMICS





## INTRODUCTION

Weight reduction, space saving, and ergonomic improvements are critical components of safe, and effective equipment. Weight has a large bearing on the performance of equipment in terms of safety, efficiency, mobility, and strength. In a lot of cases weight reduction can be employed in the design phase to solve problems in these areas. This is often done through material substitution, but considerations need to be made around the flow on effects of using a different substrate for the same application. Performance characteristics reliant on strength and environmental resilience as well as the asset or equipment's longevity and cost are important to factor into the decisions around materials.

In industrial scenario's space is often limited, both for storing when not in use as well as for personnel to be able to use the equipment effectively. Space saving in the context of storage as well as a piece of equipment's performance in the space available signify intelligent design. Thinking outside the box while satisfying performance and certification outcomes are the hallmarks of leading capability. This feeds into providing personnel the equipment they need to execute their roles with safety, efficiency, and productivity at the forefront.

The by-product of intelligent design which incorporates weight reduction, strength and performance increases and spatial awareness is ergonomics. Equipment that enables safe, efficient, and practical performance is invaluable. Achieving this in an industrial setting is only possible through design, engineering, and fabrication as a holistic process.

## HOSE LANCES CASE STUDY:

Leveraging weight reduction through material substitution and ergonomics improvements for a safer system

### PROBLEM

Our client had fabricated their own hose lances on-site for hosing down and cleaning the inside of their process chutes. The lance is used by the operator standing behind a mesh access door on the outside of the process chute. The operator pushes the lance through the gap in the mesh and cleans down the inside of the chute.

Running parallel to this was the associated manual handling issues. The lances were between 6 and 8 kilograms depending on the length. Although not extremely heavy in isolation the lances' completely solid, rigid construction coupled with delivering high pressure water created a significant safety hazard.

During one wash-down incident loose debris broke away above an operator's head which landed on the lance. The impact caused the end of the hose to hit the operator's face. The result was a significant facial injury – which could have been much worse.

### TECHNICAL REQUIREMENTS

Our client required a solution that absorbed impact while also reducing the overall weight of the lances. We needed to improve functionality and ergonomics of the lances, while satisfying the client's strict site centric specifications.

Shown to the right is the original lance  
- Mild Steel 1" SCH80 pipe and fittings  
(Ø33.4OD x 4.6 thick wall).



“ THE CORE OF THE PROBLEM IS THAT THE CURRENT SOLUTION WAS PUT TOGETHER ON-SITE AND WAS THEREFORE NOT ENGINEERED OR CERTIFIED ”

## SOLUTION - WEIGHT REDUCTION

Our solution was material substitution, from Mild to Stainless Steel. This enabled us to decrease the size of the pipe - ½" SCH40 (Ø21.3X2.77 thick wall). Although Stainless is heavier than Mild Steel, by reducing the size of pipe we drastically reduced the weight. This also allowed us to use smaller valves and fittings, creating further reduction in weight.

## SHOCK ABSORPTION

Rigidity ultimately intensifies shock scenarios, to solve this problem we developed a flexible connection. This created a mediating effect by remaining rigid enough while not under pressure, maximising performance, and function, while providing the required shock absorption characteristics when in use.

## SAFETY

Maximising safety is always top of mind when we are developing a new solution or improving on an existing one. In this case we were able to reverse the orientation of the lances on and off. Meaning if the lance is dropped it won't inadvertently turn on.

## RESULTS

- Weight of each lance has been reduced from 6-8 kilograms to 2-3 kilograms.  
The lances are more ergonomic and functional for operators
- The addition of a shock absorption feature minimises risk
- Reversal of the on/off orientation maximises safety



## MOBILE ACCESS PLATFORM CASE STUDY:

Spatial limitations, manual handling, performance, and certification solved with intelligent design

### CASE STUDY 2 – MIGHTY MOUSE

#### PROBLEM

Our client required a mobile platform to access a critical part of their plant. The platform is needed to perform maintenance on one of the head chutes located 45 metres from the ground. The task is made more difficult given the only means of access is to crane a platform onto an adjoining walkway. The walkway is narrow and is floored with grid mesh.

Australian Standards require handrails around the area of work or occupation be 900mm high from the ground someone is standing. Handrails below this height present a significant working at heights and fall hazard – in this case over 45 metres. The access platform needed to be designed to mitigate this hazard.



Aside from access to the head chute, the platform is also required for general use. The platform also needed to be as light and compact as possible. Walkways are tight and access to the area is limited. Personnel may therefore need to push the platform 300 metres or more to the maintenance area.

Prior to the design, engineering, and fabrication of this platform there was no access step or platform in existence that satisfied all these functional and safety requirements.

## TECHNICAL REQUIREMENTS

- Compact enough to fit down tight walkways and functional to make 90 degree turns navigating plant and handrail obstacles
- Light enough to be ergonomic and safe to push easily and potentially long distances
- Engineered, certified and compliant with Australian Standards

## SOLUTION

The team were able to design a platform that satisfied all requirements. The use of steel and aluminium ensured overall tare weight was kept as light as possible while maintaining stability. Attachable outriggers also allowed for less counterweights and enabled a smaller overall platform footprint.

Removable drop-in steps and handrails further narrowed the footprint and enabled the required 90 degree turning capability. To solve the safety problem associated with the use of the platform and the nearby working at heights hazards, removable protection handrails were included in the design. These are reversible to allow for use on the left and right-hand side.



## RESULTS

The finished platform is portable and easy to manoeuvre. The overall weight was kept to 260kg making the platform easy to move long distances along the grating walkways on the plant. The platform can be used anywhere along a walkway including next to existing handrails – one of the first of its kind.

## OVERALL DIMENSIONS (MM):

- In transit (just base on castors): 700H x 810L x 662W
- When erected without handrail extension: 1620H x 1085L x 1050W
- When erected with handrail extension: 1620H x 1640L x 1050W
- WLL: 150kg
- Tare weight: 261kg
- 4 swivel castors + 4 outriggers
- Forklift pockets + lifting lugs



## CONVEYOR MAINTENANCE CASE STUDY:

Manual handling minimised, safety transformed, and maintenance made easy with intelligent design and material application

### PROBLEM

Conveyor Return Idlers can only be removed or maintained while in situ. This process requires a specialised plank that enables maintenance personnel to slide under the belt to perform the task – like a car mechanic.

The existing plank design our client had implemented was constructed from 6mm plate and weighed approximately 30kg, 38kg and 47kg for the 2.3m, 3m and 3.7m planks respectively. The planks need to be transported on a vehicle to the maintenance locations and manually carried up sets of stairs. In some locations the manual handling distance is significant. The planks need to be light enough for a 2-person carry which the longest (3.7m) plank was not.

### TECHNICAL REQUIREMENTS

- 2-person carry
- Span 2.3m / 3m / 3.7m lengths
- Comply with relevant Australian and clients' engineering standards

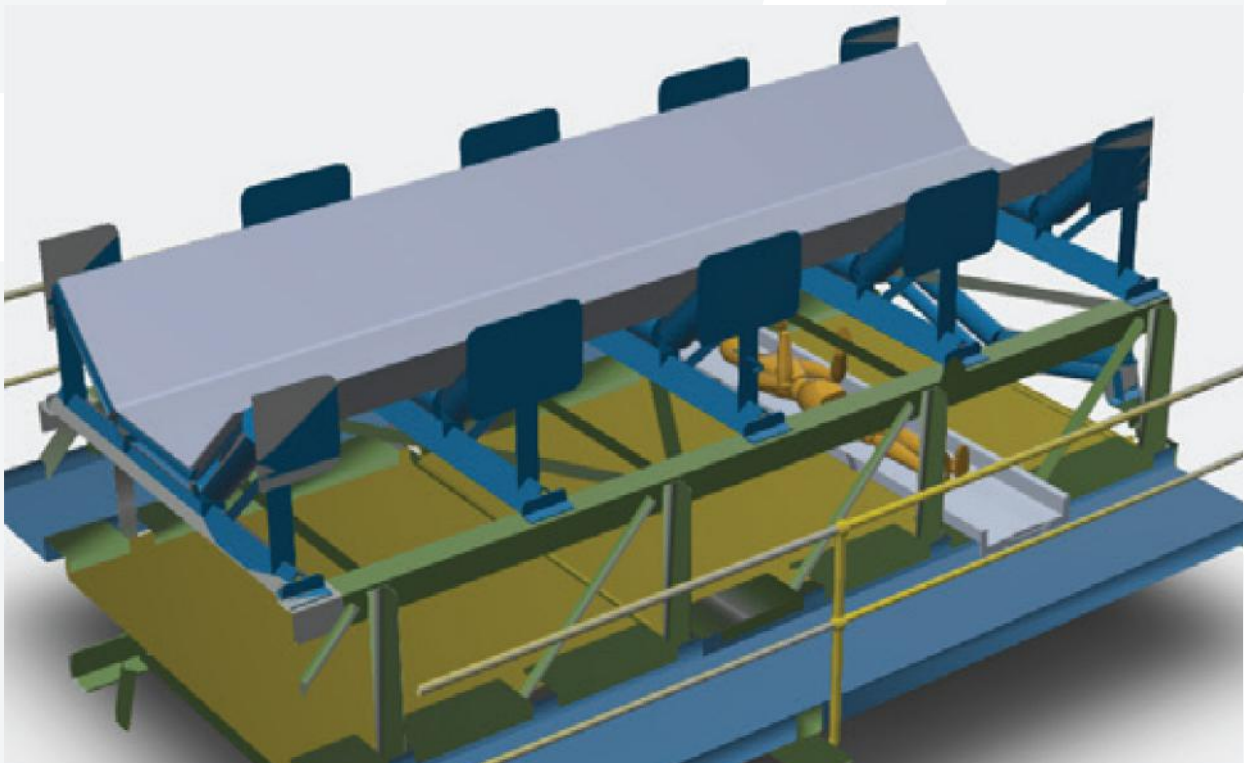

**SOLUTION**

Through intelligent redesign of the planks with a pressed plate section to reduce the deflection and a material substitution down to 5mm plate we were able to significantly reduce the weight across all three planks.

LENGTH	EXISTING DESIGN (6MM PLATE) KG	OUR DESIGN (5MM PLATE) KG	WEIGHT SAVES (KG / % SAVINGS)
2.3m	30	25	5 (17%)
3m	38	32	6 (16%)
3.7m	47	40	7 (15%)

Outside of the raw design and material upgrades to satisfy the weight and functional requirements we were able to further improve the process and maximise safety. We designed and engineered a forklift/crane able storage rack to reduce manual handling when loading the planks onto the transport ute.

The rack is also able to be craned to higher levels of the plant, meaning a significant reduction and in some cases elimination of manual handling.

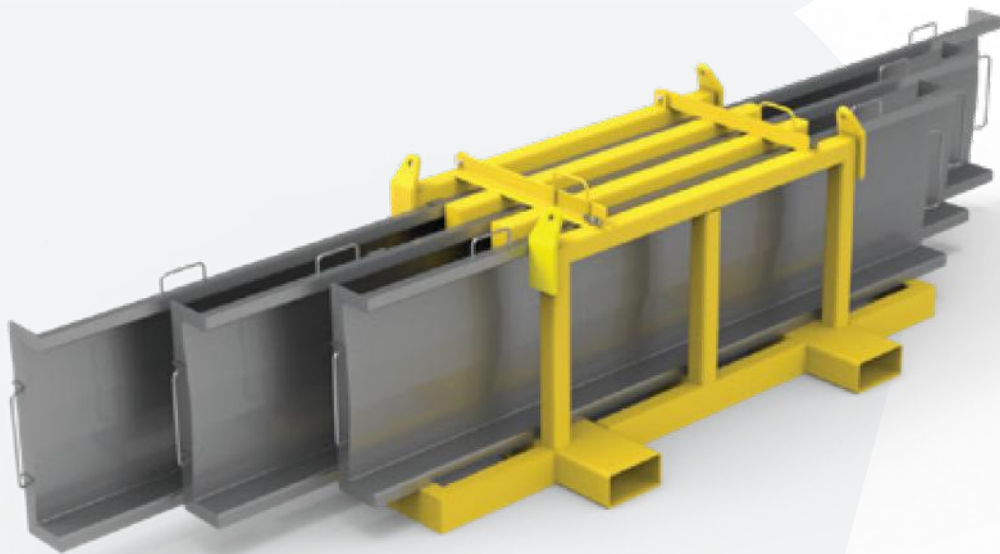

**RESULTS**

Set comprises:

- 150kg WLL PLANK of 2300mm length & 25kg tare weight
- 150kg WLL PLANK of 3000mm length & 32kg tare weight
- 150kg WLL PLANK of 3700mm length & 40kg tare weight
- Comes with Storage Rack with forklift pockets & lifting lugs

# WEIGHT REDUCTION SIMULATION PROJECT

Material substitution is an excellent way to reduce weight as well as improve functionality, performance, and economy. Our design team completed a material substitution simulation on a common workshop item – a workbench.

The parameters remained the same across the three materials and the safety and engineering outcomes had to be satisfied. The bench needed to be able to be certified and compliant with Australian Standards and have a working load limit of 750kg regardless of material and remain the same size dimensionally.

The goal of the simulation was to apply different materials to the same application to understand how much the overall tare weight of the bench could be reduced. The results are in the table below.

MATERIAL	SWL	TARE WEIGHT	WEIGHT REDUCTION
Grade 350 Steel Plate	750kg	220kg	
Strenx 700 Plate	750kg	192kg	13%
Aluminium	750kg	95kg	50%

The differences in weight between the materials are quite significant. Especially considering the dependent parameters remain the same. In isolation 1 bench may not be significant but if the same methodology was applied across a whole workshop or other structure the reduction in weight could be profound.

## STANDARD DESIGN GRADE 350 STEEL PLATE – 220KG

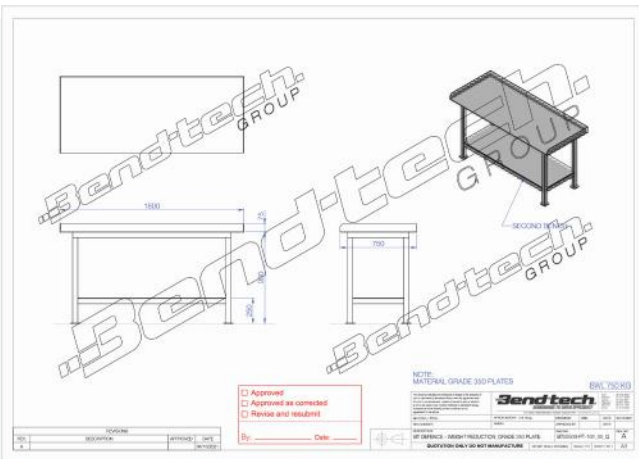

# MATERIAL SUBSTITUTION

## STRENX 700 PLATE – 192KG 13% WEIGHT REDUCTION

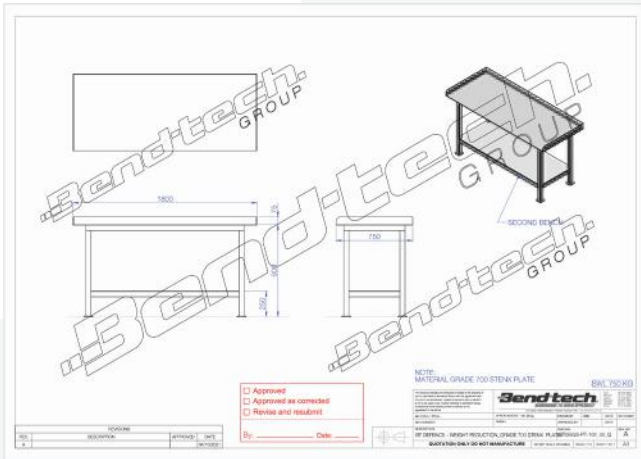

## ALUMINIUM – 95KG 56% WEIGHT REDUCTION

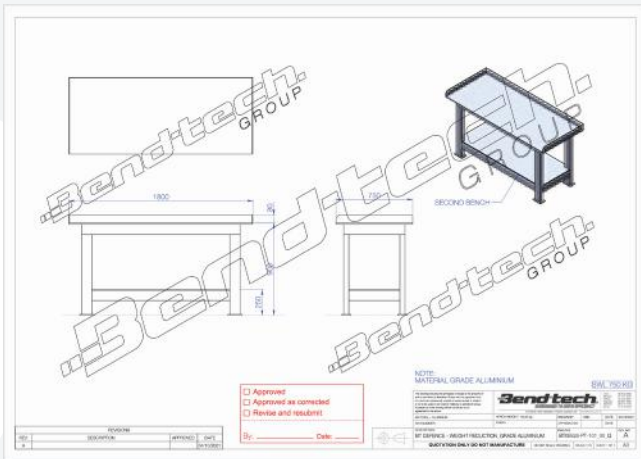

## **CAPABILITIES (BEND-TECH)**

Bend-tech is a bespoke design, engineering and fabrication firm that has been servicing the Defence industry for over 20 years. A family-owned operation which has now grown to over 75 people, Bend-tech specialises in providing innovative, engineered, and certified solutions for safety and efficiency problems to industry.

Our 10,000 sqm facility in Welshpool houses our team and local manufacturing. Our extensive capability and embedment in the resource sector has taught us that what we provide is unrivalled and is primed for the betterment and support of the Defence industry.

## **CAPABILITY**

- Design, engineering, and fabrication
- On-site consulting and 3D scanning to enable intelligent design
- Access platforms and scaffold elimination
- Weight reduction and space saving
- Manual handling elimination
- Work stands
- Equipment and material storage and handling solutions
- Workbenches and tool storage
- Site maintenance and upgrades
- Container fitouts

## **DISCRIMINATORS**

- In-house design, engineering team with over 15 internal team members
- 3D scanning, scoping, and processing capabilities
- 10000 square metres of fabrication facilities
- 80 tonne lifting capability, 20 metre underhook lift
- Our Australia-wide consultation team and processes with over 10 team members
- Dedicated research and development department and 3D printing capabilities

**B** BIGGER THAN BUSINESS

# TAKE NOTE



# TAKE NOTE



**B** BIGGER THAN BUSINESS

# TAKE NOTE

A large grid area for taking notes, consisting of a 30x30 grid of small squares. The grid is light gray and occupies the central portion of the page. There are large, faint, light gray circular shapes in the background behind the grid.

# TAKE NOTE

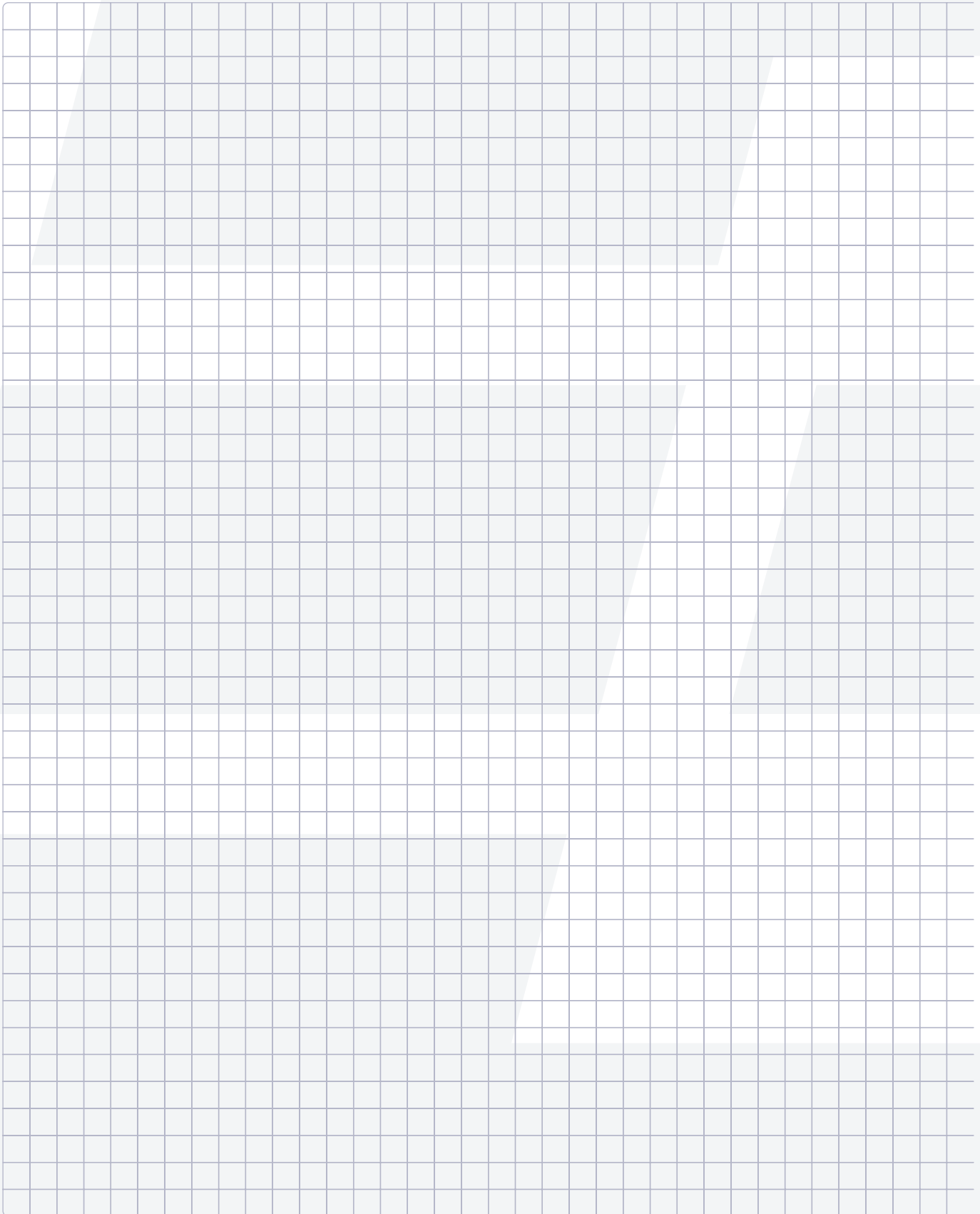

**B** BIGGER THAN BUSINESS

# TAKE NOTE



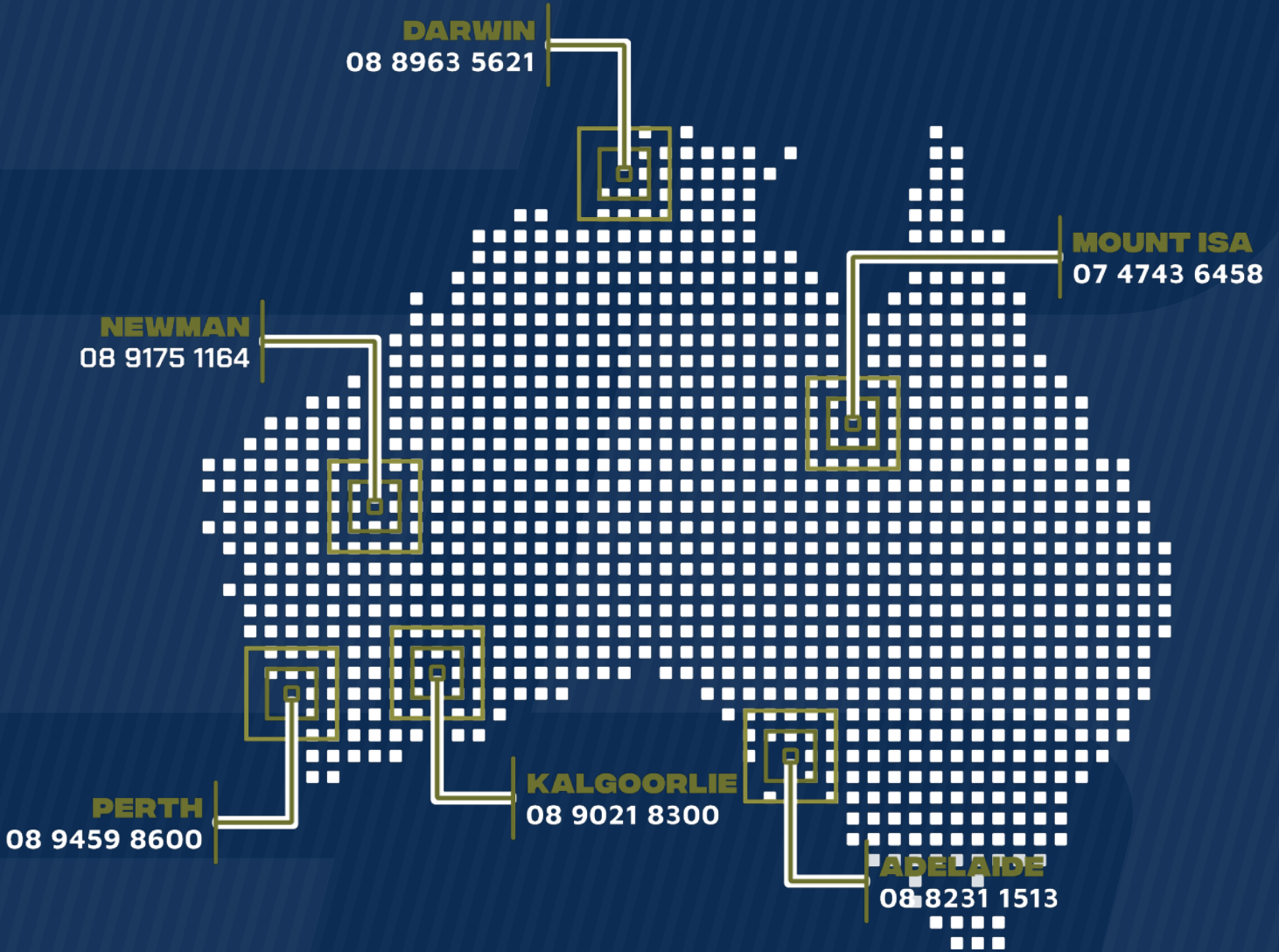

 [sales@bendtechgroup.com.au](mailto:sales@bendtechgroup.com.au)

 [www.bendtechgroup.com.au](http://www.bendtechgroup.com.au)

