



Hexagon

The BeStrong Panna Hexagon is a distinctive sports structure intended for lively Panna Football matches. With a fence height of 3'-3.71", this hexagonal arena creates a secure and dynamic environment for players. Its sturdy construction ensures durability, making it a valuable addition to parks, schools, or any recreational areas.

Attributes

Product code	4-3-037
Certificate	EN 15312
Age group	3 + years
Type	PANNA
Total area	430 ft ²
Playing area	330 ft ²

Plan View

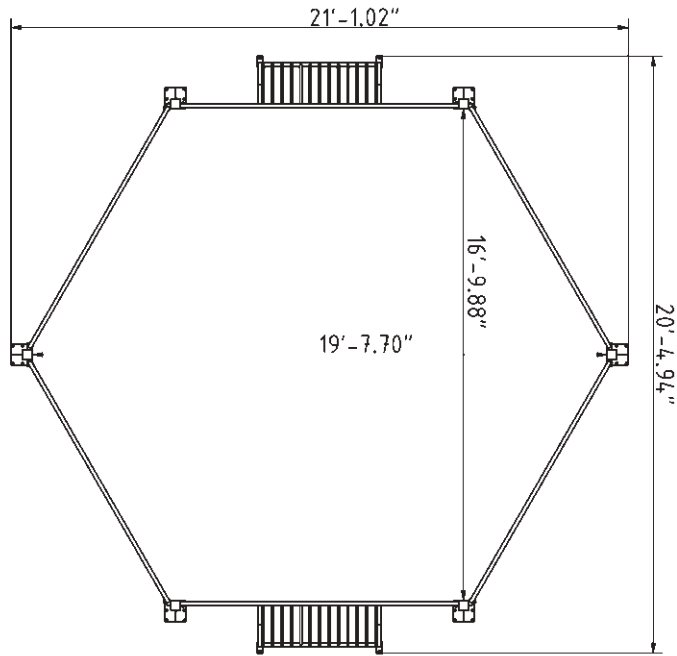

Side View

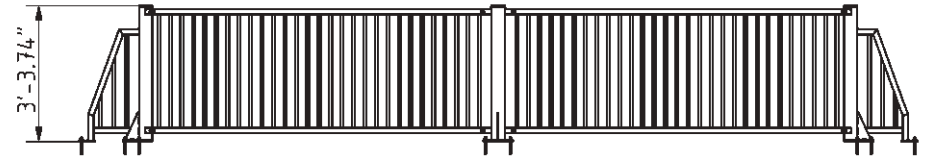

Equipment

Panna Goals

2 units

Technical specification

Anchoring option
 Net weight
 Material
 Anti-corrosion possibility
 Fence height
 Color options

Surface mounted
 747 lbs
 S235
 Galvanized or EPD
 3'-3.71"



Warranty

Structure	25 years
Steel	15 years
Paint	2 years
Plastic	5-10 years
Rubber	1-3 years
Moving parts	2 years

For custom solutions, discuss with your sales representative.

For more color options, discuss with your sales representative.

Detailed information in the warranty document

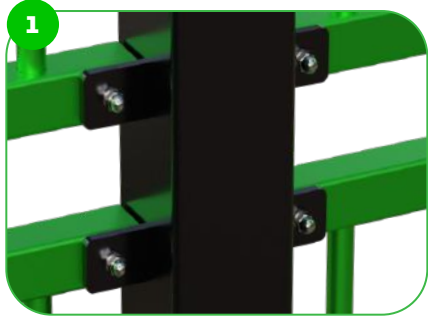

The MUGA is made of high-quality S235 steel, featuring vandal-proof stainless steel screws and nuts. It undergoes sandblasting for cleaning and receives a corrosion-resistant powder coating finish. Additionally, a galvanized surface option is available for enhanced protection and longevity.



Our MUGA features reinforced base plates fixed to a concrete base, ensuring stability and durability. This design can withstand intense sports activities, maintaining its structural integrity due to the solid foundation provided by the concrete base and the added strength of the reinforced base plates.



Our MUGA's post ends are sealed with injection moulded plastic, enhancing durability and safety. This feature ensures a smooth finish, reducing wear and tear while providing additional protection against elements.

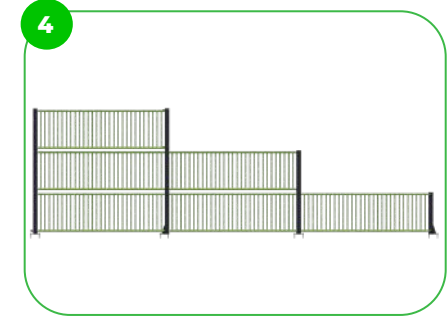

BeStrong MUGA's are designed in a modular system, offering easy customization of fence height/width, goal numbers, basketball hoops, and entrances. Tailored to your needs, they adapt to various sports activities, providing flexibility and creativity in shaping your sports area.

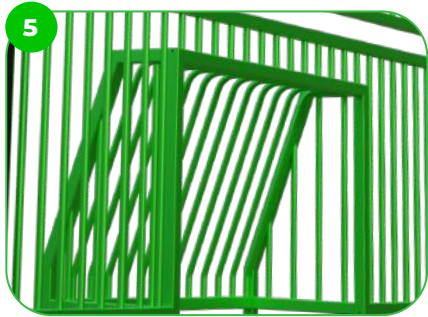

The MUGA small Panna Goals are compact and measure 4'-2"x2'-4". They are designed specifically for Panna games providing an ideal size for fast-paced, small-sided matches. These goals are perfect for both recreational play and organised tournaments. Their sturdy construction ensures durability and long-lasting performance, making them a great addition to any MUGA.

BESTRONG

 [bestrongworld](#)  [bestrongworld](#)  [usa.bestrong.com](#)  usa@bestrong.com



Sport and fitness products are compliant with the EN15312 and ASTM Standards.