



Your Supplier and
Collaborative Partner
of insulated hygienic
containers

www.ip-group.no

Your Supplier and Collaborative Partner of the highest quality hygienic insulated containers

TECHNICAL SPECIFICATION OF OUR CONTAINERS

Get familiar with our products.

At a glance:

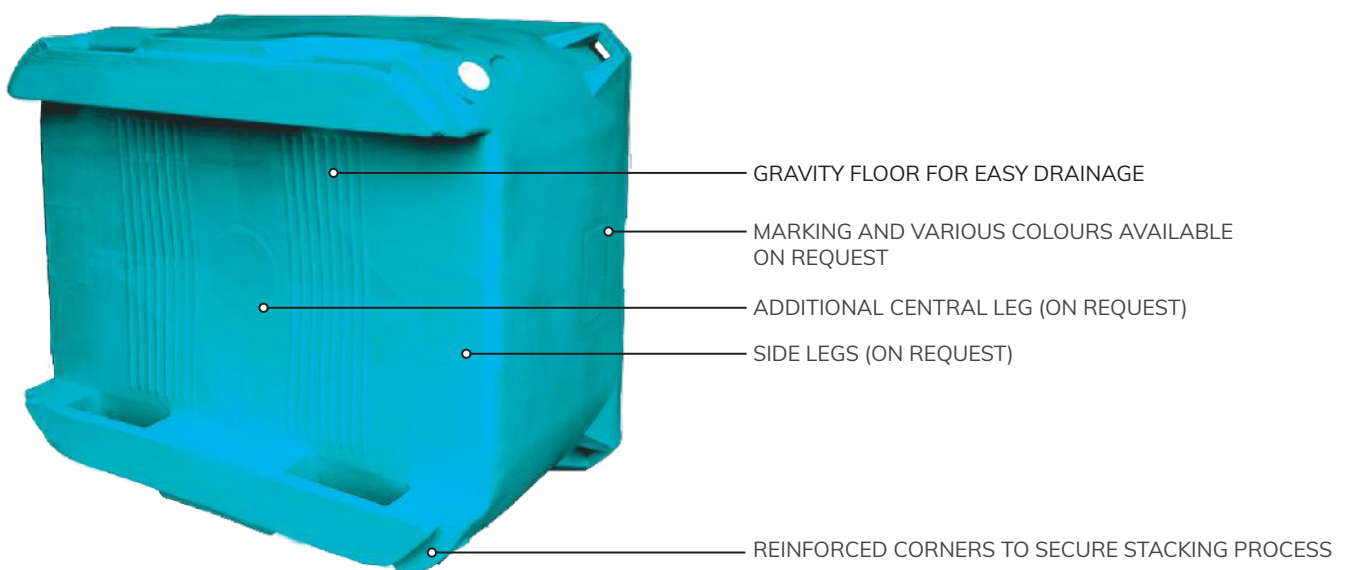
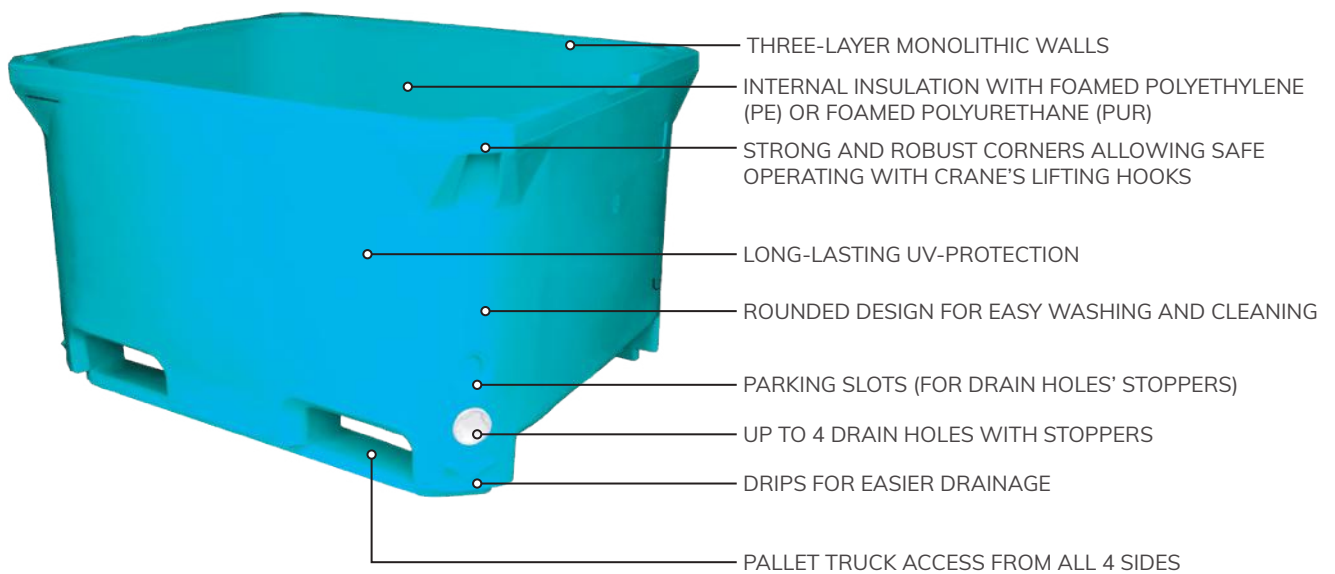

PUR Insulation

polyurethane foam

Insulation with **foamed polyurethane (PUR)** allows to maintain the temperature appropriate for the stored product.

- Insulated containers are characterized by strength and durability, significantly exceeding the parameters of ordinary insulated pallet-boxes produced using the injection method.
- Their advantage is also easy repair and recyclability.

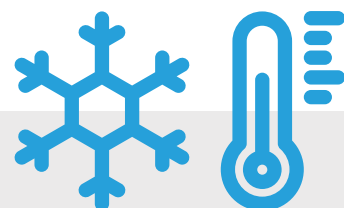

APPLICATION

Used when thermal insulation is necessary, e.g. in places with limited access to refrigeration equipment or when there are extremely high or very low temperatures.

Your Supplier and Collaborative Partner of the highest quality hygienic insulated containers

TYPE IP-70 PUR | TYPE IP-100 PUR

Ice containers such as IP-Group Type IP-70 PUR or Type IP-100 PUR are mainly used by smaller fishing vessels to store fresh or layered fish. They are used in the meat industry for pickling and storing chilled raw materials. They also work well when storage space is limited. The containers are equipped with an insulated lid.



FOOD CONTACT
COMPLIANCE

ITEM NO.	IPFP-70 PUR
EXTERNAL DIMENSIONS	750x485x390 mm
INTERNAL DIMENSIONS	675x415x275 mm
BOTTOM AND SIDEWALLS	smooth
COLOUR	beige
VOLUME IN LITRES	70 L
MATERIAL	PE-1A
INSULATION	polyurethane foam (PUR)



ITEM NO.	IPFP-100 PUR
EXTERNAL DIMENSIONS	805x530x425 mm
INTERNAL DIMENSIONS	740x465x335 mm
BOTTOM AND SIDEWALLS	smooth
COLOUR	beige
VOLUME IN LITRES	100 L
MATERIAL	PE-1A
INSULATION	polyurethane foam (PUR)



TYPE IP-310 PUR

The IP-Group Type IP-310 PUR containers are mainly used by smaller fishing vessels for storing fresh or layered fish. They are used in the meat industry for pickling and storing chilled raw materials. Thanks to its structure, the container can be moved using a forklift or hand truck. It can be accessed from all 4 sides and it can be rotated 180 degrees by a forklift. Containers can be stacked up to 4 floors.

This is the equivalent of the Type IP-310 PE container, but with polyurethane foam (PUR) insulation.

ITEM NO.	IPFP-310-1 PUR
EXTERNAL DIMENSIONS	915x715x710 mm
INTERNAL DIMENSIONS	865x665x575 mm
BOTTOM AND SIDEWALLS	smooth, 2 runners
COLOUR	beige, blue
VOLUME IN LITRES	310 L
FEATURES	2 drain holes with stoppers
MATERIAL	PE-1A
INSULATION	polyurethane foam (PUR)



TYPE IP-380 PUR

The IP-Group Type IP-380 PUR insulated container has base dimensions of 950x750 mm and height of 750 mm. Suitable for meat and poultry processing plants. Thanks to the three-walled monolithic construction with polyurethane foam (PUR) insulation as the 3rd inner wall, the container is high resistant to damage and has a longer service life than standard plastic boxes. Thick and robust handles in the upper corners guarantee stability and safety when lifting with crane's hooks. The container is designed the way it can be reached by a forklift or hand truck from all 4 sides. It is also possible to rotate the container 180 degrees using a forklift. Type IP-380 pallet-boxes can be stacked up to 4 floors.

This is the equivalent of the Type IP-380 PE container, but with polyurethane foam (PUR) insulation.

ITEM NO.	IPFP-380 PUR
EXTERNAL DIMENSIONS	950x750x750 mm
INTERNAL DIMENSIONS	880x680x610 mm
BOTTOM AND SIDEWALLS	smooth, 2 runners
COLOUR	beige, blue
VOLUME IN LITRES	365 L
FEATURES	2 drain holes with stoppers
MATERIAL	PE-1A
INSULATION	polyurethane foam (PUR)



FOOD CONTACT
COMPLIANCE



FOOD CONTACT
COMPLIANCE

Your Supplier and Collaborative Partner of the highest quality hygienic insulated containers

TYPE IP-460 PUR

The IP-Group Type IP-460 PUR container is an insulated box with a capacity of 445 litres. Such a container is suitable for transporting fresh fish and seafood on ship's board and to store fresh raw material in processing plants. The pallet-box is relatively shallow so the pressure on the product in the lower layer is relatively low. This helps avoid damage and crushing of goods such as fish. The double-walled container has internal insulation made of foamed polyurethane (PUR) making it very durable and resistant to damage. Thick and robust handles in the upper corners guarantee stability and safety when placing the box on the crane's lifting hooks. Another advantage is easy access on two sides for pallet jacks and all four sides for fork lifts.

This is the equivalent of the Type IP-460 PE container, but with polyurethane foam (PUR) insulation.

ITEM NO.	IPFP-460-1 PUR
EXTERNAL DIMENSIONS	1230x1030x580 mm
INTERNAL DIMENSIONS	1170x970x410 mm
BOTTOM AND SIDEWALLS	smooth, 2 runners
COLOUR	beige, blue
VOLUME IN LITRES	445 L
FEATURES	4 drain holes with stoppers
MATERIAL	PE-1A
INSULATION	polyurethane foam (PUR)



TYPE IP-600 PUR

The IP-Group Type IP-600 PUR insulated container is a universal container with base dimensions of 1200x1000 mm, which is one of the most popular dimensions among industrial containers. This pallet-box is suitable especially for meat and poultry processing plants. It is compatible with most single-wall pallet boxes available on the market. Thanks to the three-walled monolithic structure and used foamed polyurethane (PUR) as insulation, this container is highly resistant to damage and has a longer service life than standard plastic boxes. Thick and solid handles in the upper corners ensure stability and safety when lifting the container using the crane's hooks. The container can be handled using hand pallet trucks or forklifts.

This is the equivalent of the Type IP-600 PE container, but with polyurethane foam (PUR) insulation.

ITEM NO.	IPFP-600-1 PUR
EXTERNAL DIMENSIONS	1200x1000x750 mm
INTERNAL DIMENSIONS	1134x934x571 mm
BOTTOM AND SIDEWALLS	smooth, 2 runners
COLOUR	beige, blue
VOLUME IN LITRES	545 L
FEATURES	4 drain holes with stoppers
MATERIAL	PE-1A
INSULATION	polyurethane foam (PUR)



FOOD CONTACT
COMPLIANCE



FOOD CONTACT
COMPLIANCE

TYPE IP-605 PUR

The IP-Group Type IP-605 PUR insulated container is an insulated container with a base size of 1200x1000 mm which is one of the most popular dimensions of industrial containers. This makes it suitable for meat and poultry processing plants. It is also compatible with most commercially available single-walled pallet boxes on the market. Thanks to three-walled monolithic structure with foamed polyurethane (PUR) insulation as the 3rd inner wall - the container is highly resistant to damage and has a longer service life than standard plastic pallet boxes. Its thick and tightly formed handles in the upper corners guarantee stability and safety when lifting with crane hooks. The container can be moved using a pallet truck or a forklift. Turning with a trolley is also possible. The container has also 4 interlocking lugs that prevent it from moving when stacked.

This is the equivalent of the Type IP-605 PE container, but with polyurethane foam (PUR) insulation.

ITEM NO.	IPFP-605 PUR
EXTERNAL DIMENSIONS	1200x1000x760 mm
INTERNAL DIMENSIONS	1136x936x570 mm
BOTTOM AND SIDEWALLS	smooth, 2 runners
COLOUR	beige, blue
VOLUME IN LITRES	605 L
FEATURES	2 drain holes with stoppers 4 interlocking lugs
MATERIAL	PE-1A
INSULATION	polyurethane foam (PE)



TYPE IP-620 PUR

The IP-Group Type IP-620 PUR insulated container is very similar to the IP-Group Type IP-600 container and has a capacity of 620 liters. It is also compatible with most single-wall pallet boxes on the market. The three-walled monolithic structure and the applied insulation made of foamed polyurethane (PUR) make this container highly resistant to damage and have a longer service life than standard plastic boxes. Thick and solid handles in the upper corners ensure stability and safety when lifting the container with crane hooks. The container can be moved using hand pallet trucks or forklifts.

This is the equivalent of the Type IP-620 PE container, but with polyurethane foam (PUR) insulation.

ITEM NO.	IPFP-620-1 PUR
EXTERNAL DIMENSIONS	1220x1010x750 mm
INTERNAL DIMENSIONS	1124x924x571 mm
BOTTOM AND SIDEWALLS	smooth, 2 runners
COLOUR	beige, blue
VOLUME IN LITRES	620 L
FEATURES	4 drain holes with stoppers
MATERIAL	PE-1A
INSULATION	polyurethane foam (PUR)



FOOD CONTACT
COMPLIANCE



FOOD CONTACT
COMPLIANCE

TYPE IP-630 PUR

The IP-Group Type IP-630 PUR insulated container is a multi-functional container, recommended especially for fish and meat processing plants, aquaculture, transport and other industries. The dimensions of the container are 1200x1000 mm. This pallet box is suitable for hand pallet trucks and forklifts, providing easy access from all four sides and can be rotated 180° with a forklift. Foamed polyurethane (PUR) insulation makes the Type IP-630 a strong and highly damage-resistant version of the common pallet-box with high thermal insulation properties. *This is the equivalent of the Type IP-630 PE container, but with polyurethane foam (PUR) insulation.*

ITEM NO.	IPFP-630-1 PUR
EXTERNAL DIMENSIONS	1200x1000x785 mm
INTERNAL DIMENSIONS	1160x950x615 mm
BOTTOM AND SIDEWALLS	smooth, 2 runners
COLOUR	beige, blue
VOLUME IN LITRES	630 L
FEATURES	2 drain holes with stoppers
MATERIAL	PE-1A
INSULATION	polyurethane foam (PUR)



TYPE IP-650 PUR

The IP-Group Type IP-650 PUR insulated container is a multi-purpose pallet box used all over the world. Well-thought-out dimensions of the guides and internal legs ensure easy operation with pallet trucks, as they are accessible from all four sides. The container can also be rotated 180°. The double-walled Type IP-650 container with internal foamed polyurethane (PUR) insulation is an extremely strong, solid and easy-to-repair alternative to conventional pallet boxes. *This is the equivalent of the Type IP-650 PE container, but with polyurethane foam (PUR) insulation.*

ITEM NO.	IPFP-650 PUR
EXTERNAL DIMENSIONS	1230x1030x750 mm
INTERNAL DIMENSIONS	1170x970x580 mm
BOTTOM AND SIDEWALLS	smooth, 2 runners
COLOUR	beige, blue
VOLUME IN LITRES	630 L
FEATURES	4 drain holes with stoppers
MATERIAL	PE-1A
INSULATION	polyurethane foam (PUR)



FOOD CONTACT COMPLIANCE



FOOD CONTACT COMPLIANCE

TYPE IP-660 PUR - AVAILABLE IN 3 DIFFERENT VERSIONS

The IP-Group Type IP-660 insulated container is a multi-purpose pallet box used all over the world, regardless of the type of weights and measures used on a given continent. Such containers are suitable for fish and meat processing plants, aquaculture, transport and other industries. The containers are smooth and have drain holes allowing easy drainage of melted ice or other liquids. Well-thought-out dimensions of the guides (and optional internal legs) ensure easy operation with pallet trucks, as they are accessible from all four sides. The container can also be rotated 180°. The double-walled 660 container with internal foamed polyurethane (PUR) insulation is an extremely strong and easy-to-repair alternative to conventional pallet-boxes. We have several designs of this container so we can always adapt to customer needs. We can manufacture it with additional central legs and / or with sided legs. It's possible to make a more rounded or rectangular design also. *The product line IP-660 PUR is the equivalent of the product line IP-660 PE but with polyurethane foam (PUR) insulation.*

TYPE IP-660-2 PUR

ITEM NO.	IPFP-660-2 PUR
EXTERNAL DIMENSIONS	1230x1030x750 mm
INTERNAL DIMENSIONS	1170x970x580 mm
BOTTOM AND SIDEWALLS	smooth, 2 runners
COLOUR	beige, blue
VOLUME IN LITRES	630 L
FEATURES	4 drain holes with stoppers
MATERIAL	PE-1A
INSULATION	polyurethane foam (PUR)



VERSION WITH NARROW FORKLIFT PASSAGE

TYPE IP-660-3 PUR

ITEM NO.	IPFP-660-3 PUR
EXTERNAL DIMENSIONS	1230x1030x750 mm
INTERNAL DIMENSIONS	1170x970x580 mm
BOTTOM AND SIDEWALLS	smooth, 2 runners
COLOUR	beige, blue
VOLUME IN LITRES	635 L
FEATURES	4 drain holes with stoppers
MATERIAL	PE-1A
INSULATION	polyurethane foam (PUR)



VERSION WITH WIDE FORKLIFT PASSAGE



FOOD CONTACT COMPLIANCE

Your Supplier and Collaborative Partner of the highest quality hygienic insulated containers

TYPE IP-660-7 PUR

ITEM NO.	IPFP-660-7 PUR
EXTERNAL DIMENSIONS	1230x1030x750 mm
INTERNAL DIMENSIONS	1170x970x580 mm
BOTTOM AND SIDEWALLS	smooth, 2 runners
COLOUR	beige, blue
VOLUME IN LITRES	620 L
FEATURES	4 drain holes with stoppers
MATERIAL	PE-1A
INSULATION	polyurethane foam (PUR)



TYPE IP-1000 PUR

The IP-Group Type IP-1000 PUR insulated container is one of the largest containers in our offer. The capacity of 1000 liters allows for effective storage and transport of products. This type of container is mainly used in seafood processing (e.g. during the process of salting raw materials or transporting salmon or shrimps). They are also used in meat processing plants for curing meat. The polyurethane foam (PUR) insulation used in the containers guarantees high resistance to damage and long service life, and ensures a constant predictable product temperature. PUR insulated containers are particularly recommended as a safe, efficient and hygienic solution for the cold chain. All insulated containers are made of the highest quality materials and are approved for direct contact with food.

This is the equivalent of the Type IP-1000 PE container, but with polyurethane foam (PUR) insulation.

ITEM NO.	IPFP-1000 PUR
EXTERNAL DIMENSIONS	1470x1180x890 mm
INTERNAL DIMENSIONS	1385x1085x665 mm
BOTTOM AND SIDEWALLS	smooth, 2 runners
COLOUR	beige, blue
VOLUME IN LITRES	1000 L
FEATURES	4 drain holes with stoppers
MATERIAL	PE-1A
INSULATION	polyurethane foam (PUR)



FOOD CONTACT COMPLIANCE

TYPE IP-1010 PUR

The IP-Group Type IP-1010 PUR insulated container is our largest containers in our offer. The capacity of 1010 liters allows for effective storage and transport of products. Like the Type IP-1000 - this model of container is mainly used in seafood processing (e.g. during the process of salting raw materials or transporting salmon or shrimps). They are also used in meat processing plants for curing meat. The polyurethane foam (PUR) insulation used in the containers guarantees high resistance to damage and long service life, and ensures a constant predictable product temperature. All insulated containers are made of the highest quality materials and are approved for direct contact with food.

This is the equivalent of the Type IP-1010 PE container, but with polyurethane foam (PUR) insulation.

ITEM NO.	IPFP-1010 PUR
EXTERNAL DIMENSIONS	1240x1120x1275 mm
INTERNAL DIMENSIONS	1115x990x990 mm
BOTTOM AND SIDEWALLS	smooth, 3 runners
COLOUR	beige, blue
VOLUME IN LITRES	1010 L
FEATURES	2 drain holes with stoppers
MATERIAL	PE-1A
INSULATION	polyurethane foam (PUR)



AVAILABLE OPTIONS

- no drain holes
- 1-4 drain holes *
- QR codes and marking
- barcode insert
- parking slot for stopper **
- RFID
- thread BSP 2" built into the mould
- additional single central leg ***
- 2 additional side legs ****
- reduction from BCS 2" thread to BSP 2"

* Type IP-605 / Type IP-630 - max. 2 drain holes

** Type IP-460 / Type IP-630 - no option

*** Type IP-460 / Type IP-620 / Type 650 / Typ IP-660-2 - no option

**** Option available only for: Type IP-660-3 / Type IP-660-7



FOOD CONTACT
COMPLIANCE

PE Insulation

polyethylene foam

The use of insulation in the form of **foamed polyethylene (PE) insulation** allows us to manufacture the strongest containers on the market while also ensuring the best thermal properties. Such pallet boxes guarantee the highest hygiene standards and product safety.

- The completely closed structure, smooth and profiled surface (with drain holes) allow for maintaining cleanliness and meeting all stringent hygiene requirements.
- The production of pallet containers from a single raw material ensures their extraordinary stability and the possibility of full recycling.



APPLICATION

Tasks requiring high durability due to the weight and hygiene of the load.

TYPE IP-310 PE

The IP-Group Type IP-310 PE containers are mainly used by smaller fishing vessels for storing fresh or layered fish. They are used in the meat industry for pickling and storing chilled raw materials. Thanks to its structure, the container can be moved using a forklift or hand truck. It can be accessed from all 4 sides and it can be rotated by 180 degrees by a forklift. Containers can be stacked up to 4 floors. Triple-walled monolithic construction makes this container highly resistant to damage. *This is the equivalent of the Type IP-310 PUR container, but with polyethylene foam (PE) insulation.*

ITEM NO.	IPFP-310-1 PE
EXTERNAL DIMENSIONS	915x715x710 mm
INTERNAL DIMENSIONS	865x665x575 mm
BOTTOM AND SIDEWALLS	smooth, 2 runners
COLOUR	beige, blue
VOLUME IN LITRES	310 L
FEATURES	2 drain holes with stoppers
MATERIAL	PE-1A
INSULATION	polyethylene foam (PE)



TYPE IP-380 PE

The IP-Group Type IP-380 PE insulated container has base dimensions of 950x750 mm and height of 750 mm. Suitable for meat and poultry processing plants. Thanks to the three-walled monolithic construction and polyethylene foam (PE) insulation, the container is highly resistant to damage and has a longer service life than standard plastic boxes. Thick and robust handles in the upper corners guarantee stability and safety when lifting with crane's hooks. The container is designed the way it can be reached by a forklift or hand truck from all 4 sides. It is also possible to rotate the container 180 degrees using a forklift. Type IP-380 pallet-boxes can be stacked up to 4 floors. *This is the equivalent of the Type IP-380 PUR container, but with polyethylene foam (PE) insulation.*

ITEM NO.	IPFP-380 PE
EXTERNAL DIMENSIONS	950x750x750 mm
INTERNAL DIMENSIONS	880x680x610 mm
BOTTOM AND SIDEWALLS	smooth, 2 runners
COLOUR	beige, blue
VOLUME IN LITRES	365 L
FEATURES	2 drain holes with stoppers
MATERIAL	PE-1A
INSULATION	polyethtlene foam (PUR)



FOOD CONTACT
COMPLIANCE



FOOD CONTACT
COMPLIANCE

Your Supplier and Collaborative Partner of the highest quality hygienic insulated containers

TYPE IP-400 PE

The IP-Group Type IP-400 PE insulated container is the shallowest model of our containers with an ISO bottom - dimensions of 1200x1000 mm. The relatively low walls of the container allow to avoid heavy pressure on the product, for example on fish placed in the layer closest to the bottom. These containers can be stacked, so they can be also transported in stacks, and stored in warehouses or processing plants. The IP-400 PE Type has a three-walled monolith structure with internal insulation in the form of foamed polyethylene (PE) - as the 3rd inner wall, ensuring durability and high resistance to damage. Thick and robust handles in the upper of the pallet-box's corners guarantee stability and safety when lifting the container with crane's hooks. Well-thought-out dimensions of the skids and internal legs enable the pallet truck to be operated from all four sides and the container to be rotated 180 degrees.

ITEM NO.	IPFP-400-1 PE
EXTERNAL DIMENSIONS	1200x1000x570 mm
INTERNAL DIMENSIONS	1135x935x380 mm
BOTTOM AND SIDEWALLS	smooth, 2 runners
COLOUR	beige, blue
VOLUME IN LITRES	380 L
FEATURES	4 drain holes with stoppers
MATERIAL	PE-1A
INSULATION	polyethylene foam (PE)



TYPE IP-460 PE

The IP-Group Type IP-460 PE container is an insulated box with a capacity of 445 litres. Such a container is suitable for transporting fresh fish and seafood on ship's board and to store fresh raw material in processing plants. This pallet-box is relatively shallow so the pressure on the product in the lower layer is relatively low. This helps avoid damage and crushing of goods such as fish or crabs. The double-walled container has internal insulation made of foamed polyethylene (PE) making it very durable and highly resistant to damage. Thick and robust handles in the upper corners guarantee stability and safety when placing the box on the crane's lifting hooks. Another advantage is easy access on two sides for pallet jacks and all four sides for fork lifts.

This is the equivalent of the Type IP-460 PUR container, but with polyethylene foam (PE) insulation.

ITEM NO.	IPFP-460-1 PE
EXTERNAL DIMENSIONS	1230x1030x580 mm
INTERNAL DIMENSIONS	1170x970x410 mm
BOTTOM AND SIDEWALLS	smooth, 2 runners
COLOUR	beige, blue
VOLUME IN LITRES	445 L
FEATURES	4 drain holes with stoppers
MATERIAL	PE-1A
INSULATION	polyethylene foam (PE)



FOOD CONTACT COMPLIANCE



FOOD CONTACT COMPLIANCE

TYPE IP-600 PE

The IP-Group Type IP-600 PE insulated container is a universal container with base dimensions of 1200x1000 mm, which is one of the most popular dimensions among industrial containers. This pallet-box is suitable especially for meat and poultry processing plants. It is compatible with most single-walled pallet boxes available on the market. Thanks to three-walled monolithic structure and used foamed polyethylene (PE) insulation, this container is highly resistant to damage and has a longer service life than standard plastic boxes. Thick and solid handles in the upper corners ensure stability and safety when lifting the container using the crane's hooks. The container can be handled using hand pallet trucks or forklifts.

This is the equivalent of the Type IP-600 PUR container, but with polyethylene (PE) insulation.

ITEM NO.	IPFP-600-1 PE
EXTERNAL DIMENSIONS	1200x1000x750 mm
INTERNAL DIMENSIONS	1134x934x571 mm
BOTTOM AND SIDEWALLS	smooth, 2 runners
COLOUR	beige, blue
VOLUME IN LITRES	545 L
FEATURES	2 drain holes with stoppers
MATERIAL	PE-1A
INSULATION	polyethylene foam (PE)



TYPE IP-605 PE

The IP-Group Type IP-605 PE insulated container is an insulated container with a base size of 1200x1000 mm which is one of the most popular dimensions of industrial containers. This makes it suitable for meat and poultry processing plants. It is also compatible with most commercially available single-walled pallet boxes on the market. Thanks to three-walled monolithic structure with foamed polyethylene (PE) insulation as the 3rd inner wall - the container is highly resistant to damage and has a longer service life than standard plastic pallet boxes. Its thick and tightly formed handles in the upper corners guarantee stability and safety when lifting with crane hooks. The container can be moved using a pallet truck or a forklift. Turning with a trolley is also possible. The container has also 4 interlocking lugs that prevent it from moving when stacked.

This is the equivalent of the Type IP-605 PUR container, but with polyethylene (PE) insulation.

ITEM NO.	IPFP-605 PE
EXTERNAL DIMENSIONS	1200x1000x760 mm
INTERNAL DIMENSIONS	1136x936x570 mm
BOTTOM AND SIDEWALLS	smooth, 2 runners
COLOUR	beige, blue
VOLUME IN LITRES	605 L
FEATURES	2 drain holes with stoppers 4 interlocking lugs
MATERIAL	PE-1A
INSULATION	polyethylene foam (PE)



FOOD CONTACT
COMPLIANCE



FOOD CONTACT
COMPLIANCE

Your Supplier and Collaborative Partner of the highest quality hygienic insulated containers

TYPE IP-620 PE

The IP-Group Type IP-620 PE insulated container is very similar to the IP-Group Type IP-600 container and has a capacity of 620 liters. It is also compatible with most single-wall pallet boxes on the market. The three-walled monolithic structure and the applied insulation made of foamed polyethylene (PE) make this container highly resistant to damage and have a longer service life than standard plastic boxes. Thick and solid handles in the upper corners ensure stability and safety when lifting the container with crane hooks. The container can be moved using hand pallet trucks or forklifts.

This is the equivalent of the Type IP-620 PUR container, but with polyethylene foam (PE) insulation.

ITEM NO.	IPFP-620-1 PE
EXTERNAL DIMENSIONS	1220x1010x750 mm
INTERNAL DIMENSIONS	1124x924x571 mm
BOTTOM AND SIDEWALLS	smooth, 2 runners
COLOUR	beige, blue
VOLUME IN LITRES	620 L
FEATURES	4 drain holes with stoppers
MATERIAL	PE-1A
INSULATION	polyethylene foam (PE)



TYPE IP-630 PE

The IP-Group Type IP-630 PE insulated container is a multi-functional container, recommended especially for fish and meat processing plants, aquaculture, transport and other industries. The dimensions of the container are 1200x1000 mm. This pallet-box is suitable for hand pallet trucks and forklifts, providing easy access from all four sides and can be rotated 180° with a forklift. Foamed polyethylene (PE) insulation makes the Type IP-630 a strong and high damage-resistant version of the common pallet-box with high thermal insulation properties.

This is the equivalent of the Type IP-630 PUR container, but with polyethylene foam (PE) insulation.

ITEM NO.	IPFP-630-1 PE
EXTERNAL DIMENSIONS	1200x1000x785 mm
INTERNAL DIMENSIONS	1160x950x615 mm
BOTTOM AND SIDEWALLS	smooth, 2 runners
COLOUR	beige, blue
VOLUME IN LITRES	630 L
FEATURES	2 drain holes with stoppers
MATERIAL	PE-1A
INSULATION	polyethylene foam (PE)



FOOD CONTACT
COMPLIANCE



FOOD CONTACT
COMPLIANCE

TYPE IP-650 PE

The IP-Group Type IP-650 PE insulated container is a multi-purpose pallet-box used all over the world. Well-thought-out dimensions of the guides and internal legs ensure easy operation with pallet trucks, as they are accessible from all four sides. The container can also be rotated 180°. The double-walled 650 container with internal foamed polyethylene (PE) insulation is an extremely strong, solid and easy-to-repair alternative to conventional pallet boxes.

This is the equivalent of the Type IP-650 PUR container, but with polyethylene foam (PE) insulation.

ITEM NO.	IPFP-650 PE
EXTERNAL DIMENSIONS	1230x1030x750 mm
INTERNAL DIMENSIONS	1170x970x580 mm
BOTTOM AND SIDEWALLS	smooth, 2 runners
COLOUR	beige, blue, other colours on request
VOLUME IN LITRES	630 L
FEATURES	4 drain holes with stoppers
MATERIAL	PE-1A
INSULATION	polyethylene foam (PE)



TYPE IP-660-2 PE

The IP-Group Type IP-660-2 PE insulated container is a universal container used worldwide, regardless of the type of weights and measures used on a given continent. This type of container is useful in fish and meat processing plants, aquaculture, transport and other industries. There are 2 types of that container - without holes or with drainage holes in each corner so that melted ice or other liquids can flow out easily. Well-thought-out dimensions of the skids (inner central leg or side legs as option) guarantee easy handling with pallet trucks from all four sides. It's also possible to rotate 180° using a forklift. The double-wall Type IP-660-2 container with internal insulation in the form of foamed polyethylene (PE) is an extremely durable, robust and easy-to-repair alternative to conventional pallet-boxes. We have several forms of this size of container, so we can adapt to the needs of each customer and configure the product e.g. by adding a central leg or using a more rounded rectangular structure. Version with narrow built-in legs within skids. *This is the equivalent of the Type IP-660-2 PUR container, but with polyethylene foam (PE) insulation.*

ITEM NO.	IPFP-660-2 PE
EXTERNAL DIMENSIONS	1230x1030x750 mm
INTERNAL DIMENSIONS	1170x970x580 mm
BOTTOM AND SIDEWALLS	smooth, 2 runners
COLOUR	beige, blue, other colours on request
VOLUME IN LITRES	630 L
FEATURES	4 drain holes with stoppers
MATERIAL	PE-1A
INSULATION	polyethylene foam (PE)



VERSION WITH NARROW FORKLIFT PASSAGE



FOOD CONTACT
COMPLIANCE



FOOD CONTACT
COMPLIANCE

TYPE IP-660-3 PE

The IP-Group Type IP-660-3 PE insulated container is a universal container used all over the world, regardless of the type of weights and measures used on a given continent. This type of containers work fine in fish and meat processing plants, aquaculture, transport and other industries. There are 2 variants of this containers - without holes or with drainage holes in each corner so that melted ice or other liquids can flow out easily. Well-thought-out dimensions of the skids guarantee easy operation with pallet trucks from all four sides. It's also possible to rotate 180° using a forklift. The double-walled Type IP-660 container with internal insulation in the form of foamed polyethylene (PE) is an extremely durable, robust and easy-to-repair alternative to conventional pallet-boxes. We have several forms of this container, so we can adapt to the needs of each customer and configure the product e.g. by adding a central leg or using a more rounded or rectangular structure. Version with wide built-in legs within skids.

This is the equivalent of the Type IP-660-3 PUR container, but with polyethylene foam (PE) insulation.

ITEM NO.	IPFP-660-3 PE
EXTERNAL DIMENSIONS	1230x1030x750 mm
INTERNAL DIMENSIONS	1170x970x580 mm
BOTTOM AND SIDEWALLS	smooth, 2 runners
COLOUR	beige, blue, other colours on request
VOLUME IN LITRES	635 L
FEATURES	4 drain holes with stoppers
MATERIAL	PE-1A
INSULATION	polyethylene foam (PE)



VERSION WITH WIDE FORKLIFT PASSAGE

TYPE IP-660-7 PE

The IP-Group Type IP-660-7 PE insulated container is a versatile container used worldwide, regardless of the type of weights and measures used on a given continent. This type of containers do its job well in fish and meat processing plants, aquaculture, transport and other industries. There are 2 types of that containers - without holes or with drainage holes in each corner so that melted ice or other liquids can flow out easily. Well-thought-out dimensions of the skids and inner leg guarantee easy handling with pallet trucks from all four sides. It's also possible to rotate 180° using a forklift. The double-walled Model 660 container with internal insulation in the form of foamed polyethylene (PE) is an extremely durable, robust and easy-to-repair alternative to conventional pallet-boxes. We have several forms of this container, so we can adapt to each customer's needs and configure the product e.g. by adding a central leg or using a more rounded or rectangular design.

ITEM NO.	IPFP-660-7 PE
EXTERNAL DIMENSIONS	1230x1030x750 mm
INTERNAL DIMENSIONS	1170x970x580 mm
BOTTOM AND SIDEWALLS	smooth, 2 runners
COLOUR	beige, blue
VOLUME IN LITRES	620 L
FEATURES	4 drain holes with stoppers
MATERIAL	PE-1A
INSULATION	polyethylene foam (PE)



FOOD CONTACT COMPLIANCE



FOOD CONTACT COMPLIANCE

TYPE IP-1000 PE

The IP-Group Type IP-1000 PE insulated container is one of the largest containers in our offer. The capacity of 1000 liters allows for effective storage and transport of products. This type of container is mainly used in seafood processing (e.g. during the process of salting raw materials or transporting salmon or shrimps). They are also used in meat processing plants for curing meat. The polyethylene foam (PE) insulation used in the containers guarantees high resistance to damage and long service life, and ensures a constant predictable product temperature. PE insulated containers are particularly recommended as a safe, efficient and hygienic solution for the cold chain. All insulated containers are made of the highest quality materials and are approved for direct contact with food. *This is the equivalent of the Type IP-1000 PUR container, but with polyethylene foam (PE) insulation.*

ITEM NO.	IPFP-1000 PE
EXTERNAL DIMENSIONS	1470x1180x890 mm
INTERNAL DIMENSIONS	1385x1085x665 mm
BOTTOM AND SIDEWALLS	smooth, 2 runners
COLOUR	beige, blue
VOLUME IN LITRES	1000 L
FEATURES	4 drain holes with stoppers
MATERIAL	PE-1A
INSULATION	polyethylene foam (PE)



TYPE IP-1010 PE

The IP-Group Type IP-1010 PE insulated container is our largest containers in our offer. The capacity of 1010 liters allows for effective storage and transport of products. Like the Type IP-1000 - this model of container is mainly used in seafood processing (e.g. during the process of salting raw materials or transporting salmon or shrimps). They are also used in meat processing plants for curing meat. The polyethylene foam (PE) insulation used in the containers guarantees high resistance to damage and long service life, and ensures a constant predictable product temperature. All insulated containers are made of the highest quality materials and are approved for direct contact with food. *This is the equivalent of the Type IP-1010 PUR container, but with polyethylene foam (PE) insulation.*

ITEM NO.	IPFP-1010 PE
EXTERNAL DIMENSIONS	1240x1120x1275 mm
INTERNAL DIMENSIONS	1115x990x990 mm
BOTTOM AND SIDEWALLS	smooth, 3 runners
COLOUR	beige, blue
VOLUME IN LITRES	1010 L
FEATURES	2 drain holes with stoppers
MATERIAL	PE-1A
INSULATION	polyethylene foam (PE)



FOOD CONTACT
COMPLIANCE



FOOD CONTACT
COMPLIANCE

Your Supplier and Collaborative Partner of the highest quality hygienic insulated containers

AVAILABLE OPTIONS

- no drain holes
- 1-4 drain holes *
- QR codes and marking
- barcode insert
- parking slot for stopper **
- RFID
- thread BSP 2" built into the mould
- additional single central leg ***
- 2 additional side legs ****
- reduction from BCS 2" thread to BSP 2"

* Type IP-605 / Type IP-630 - max. 2 drain holes

** Type IP-460 / Type IP-630 - no option

*** Type IP-460 / Type IP-620 / Type IP-650 / Type IP-660-2 - no option

**** Option available only for: Type IP-660-3 / Type IP-660-7

Insulated Eurobin (meat trolley)

Plastic insulated meat trolleys are mainly used in food processing plants, especially in the meat, fish and poultry industries. They are also ideal for applications requiring the efficient transportation of Cat. 3 waste. They enable convenient transport between workstations. The weight of our plastic Eurobin is only 22 kg and they have capacity of 200 litres.

Our containers are considerably lighter than comparable stainless steel versions and thanks to special wheels, are also much quieter (the difference in noise during filling and transport of products is on average 17dB - compared to the stainless steel versions). The outer and inner surface of our plastic trolleys is completely smooth, which allows for easy and quick cleaning and reduces cleaning costs.

The foamed polyethylene (PE) insulation ensures the safety of the transported product. The meat trolleys are equipped with an ergonomic handles for convenient handling.

ITEM NO.	IPFP-200
EXTERNAL DIMENSIONS	820x720x700 mm
DESIGN	bottom and walls reinforced, smooth, base on 4 wheels
CONTAINER COLOUR	red, blue, white, yellow
WHEEL COLOUR	white
CAPACITY IN LITRES	200 L
WEIGHT	22 kg
MATERIAL	PE
INSULATION	foamed polyethylene (PE) or foamed polyurethane (PUR)



FOOD CONTACT
COMPLIANCE

Your Supplier and Collaborative Partner of the highest quality hygienic insulated containers

LIDS

All containers have suitable lids with PUR insulation. They are fitted with UV-resistant rubber tensioners. Their use does not make them completely watertight. The containers can be stacked with the lids.

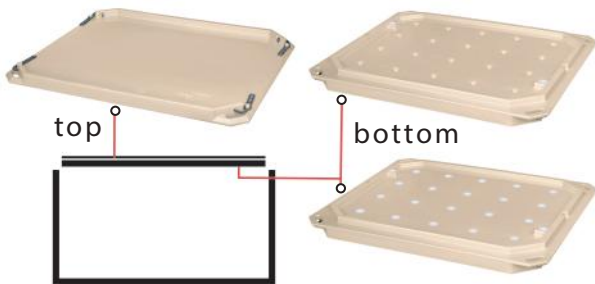

FOIL COVERS FOR BOX PALLETS AND INSULATED CONTAINERS

The covers are made of tear-resistant polyethylene (PE). This inexpensive but effective solution provides a hygienic seal that isolates the smell of products. The stretchable coating is also easy to apply and remove. The covers are intended for single use. We offer covers for Type IP-660 insulated containers and for 1200x1000 mm pallet-boxes. Foil covers for steel and plastic cymbers are also available.



ADAPTER

Adapter: BCS 56x4 external thread to BSP 2" internal thread.



RUBBER TENSIONERS

Strong, UV-resistant rubber tensioners for closing the containers with lids.

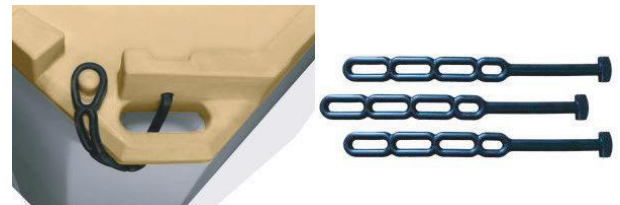

RFID IDENTIFICATION

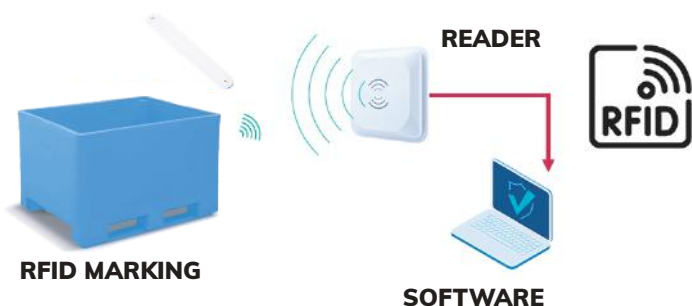

DRAIN PLUG

Drain plug with a 3/4" hole allows the attachment of a hose or drain valve.



ABOUT OUR CONTAINERS

Check out the advantages of our containers.

Lifting and operating:

The containers are manufactured on a pallet base conforming to generally accepted standards and allow four-way access by a hand pallet truck and a forklift. All containers have safety handles that allow them to be lifted when fully loaded and facilitate the movement of empty containers.

Chemical resistance:

Polyethylene is resistant to most weak acids and bases, as well as other common substances. More detailed specifications on their chemical tolerance can be obtained from the manufacturer.

Stacking, with or without lids:

All IP-Group containers of the same type, and most insulated containers from other manufacturers, stack together.

Types **IP-400-1**, **600** i **IP-630-1** can be stacked.

Types **IP-460-1**, **660-1**, **660-2**, **660-3** .

IMPORTANT !

Freezing – using containers in freezers:

The use of insulated containers to freeze their contents is not recommended due to the possibility of structural damage.

Throwing frozen goods into insulated containers is prohibited, any damage caused by sharp edges and / or the weight of frozen items will not be covered by the warranty.

Your Supplier and Collaborative Partner of the highest quality hygienic insulated containers

Stacking:

Insulated containers can be stacked, even fully loaded. A moderate number of stacked containers, good care and regular maintenance make the containers last much longer. PE insulated containers are stronger than PUR containers and can therefore be stacked higher. The maximum stacking height varies for different types of containers and the weight of their contents. Nevertheless, it should always be considered that the risk of an accident increases when the containers are stacked higher than necessary.

Note that the risk of damage to a container at the bottom of the stack increases in direct proportion to the number of containers in the stack. Therefore it's important to place the stacks on an even surface and with the weight evenly distributed. It is also necessary that the containers stand exactly one inside the other when stacked. Otherwise, the entire stack may tip over, causing injury to people nearby.

While there is no universal rule on how many containers can be stacked, factors such as the weight of the contents and the age and condition of the containers should always be considered in each individual case. Extreme care should always be taken when stacking containers. When insulated containers are stacked one container in two (cap) and loaded onto a truck or other transport, they should only be moved by a forklift or a similar device.

It is not advisable to drop containers from a truck, drop them from a transport vehicle or drop them from any height (1 metre or more), such as a forklift.

It is then very likely that the handles of the plastic container inside the sandwich will damage the inside of the lower plastic container.

The danger of damage increases dramatically when the temperature drops below 0°C.



MARKING

Branding - stand out !

As a supplier of insulated containers, we can offer marking of each container according to the individual customer needs.

SCREEN PRINTING METHOD

We offer screen printing on every container. Screen printing is a single-colour print applied with a special ink. It is possible to apply the customer's logo thanks to which the container can be easily identified. Screen-printed markings are made in one colour, usually black or white.

ENGRAVING

At IP-Group we also offer engraved markings on our products to ensure individual identification of the container. Engraved markings are permanent and cannot be removed without any trace. Possible markings include serial number, company name, destination or intended use e.g. CAT.3

IN-MOULD MARKING

For the most demanding customers, we also offer multi-colour graphic markings for insulated containers. In-mould marking is a visual way of identifying the customer with a company logo or any other graphic. This technology can also be used for marketing purposes or to empower a brand. This unique method of marking is often used to present user guidelines or other messages that need to be presented for a specific product application.

Your Supplier and Collaborative Partner of the highest quality hygienic insulated containers

COLOURING

Colours compliant with the HACCP system.

One of the key elements in maintaining **the highest level of cleanliness and hygiene** in a production facility is to prevent "clean" and "dirty" containers from crossing paths

This is achieved by using appropriate colour scheme for transport and storage packaging, according to which six colours have been defined for both insulated containers and other packaging and accessories in processing plants.



INTENDED FOR RAW FISH, SEAFOOD

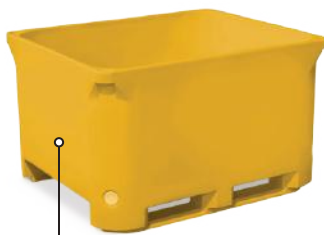

INTENDED FOR RAW POULTRY

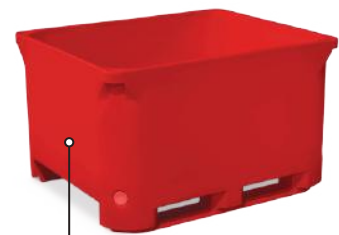

INTENDED FOR RAW MEAT

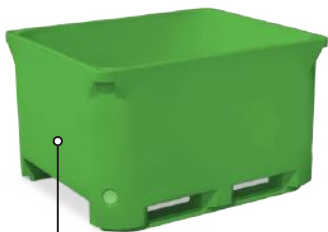

INTENDED FOR FRUIT AND VEGETABLES



INTENDED FOR COOKED MEAT AND SAUSAGES



OR DAIRY PRODUCTS AND BREAD

INDIVIDUAL COLOURING

On request, we are able to produce any individual colour of the container, starting from just from 1 piece !

SAFETY

Safety first.

Always follow these basic rules of safety !

- never lift containers on hooks if their top corners are damaged or have been previously repaired
- always keep a safe distance from containers being carried or transported even if they are stacked
- use protective health and safety clothing
- when transporting containers in a stack with a forklift, always do so by carefully picking up the container on the long side. Skids will provide extra stability when driving over long distances and uneven surfaces
- ensure that the slope of the floor does not affect the stability of high stacks
- always repair slightly damaged containers on a regular basis and remove used or severely damaged containers from circulation

When stacking insulated containers make sure that:

- all containers have no damage to the corner handles, walls and legs or skids
- the place on which you place the containers has an even and stable surface
- the stack of containers stands straight and does not tilt due to uneven floor surfaces or improper stacking
- the containers are stacked on top of each other and sit evenly and straight on top of each other



Your Supplier and Collaborative Partner of the highest quality hygienic insulated containers

HIGIENA PRACY

Fine feathers make fine birds !

Keeping insulated containers clean is an extremely important aspect of their use.

A clean container shows its owner and his respect for the customer. Regular cleaning significantly extends the life of the containers. Repairs are significantly reduced and the quality of transport services always remain at the highest level.

In addition, regular professional cleaning saves time and money. This contributes to customer satisfaction and leads to long-term customer satisfaction.

REMEMBER !

- always wash insulated containers after use
- if you notice any damage to the container, remember not to use it any longer but to have it repaired immediately
- use containers as intended, for foods products only

If you understand that the cleanliness of insulated containers proves your professionalism and the quality of the transported goods in the eyes of your customers, it means that you are one step ahead of the competition.

With high daily volumes, it is also possible to build a permanent washing point by installing a container washing station in a designated area, which will certainly help reduce logistics costs. Upon request, we will also take care of logistics.

Contact us and we will develop a suitable cleaning concept for You !



+47 960 49 556

info@ip-group.no
www.ip-group.no

RENTAL

Expect the unexpected.

From now on, unexpected orders from customers during peak season are no longer a problem !

At FACH-PAK, we offer the rental of our insulated products so that you can easily and economically meet the objectives set for your company by your customers. Just tell us the model, quantity, and planned rental period and we will prepare the expected offer for you within 24 hours.

You are welcome to inquire:

+48 59 845 50 00 | info@fach-pak.com



Producer of the highest quality hygienic insulated containers

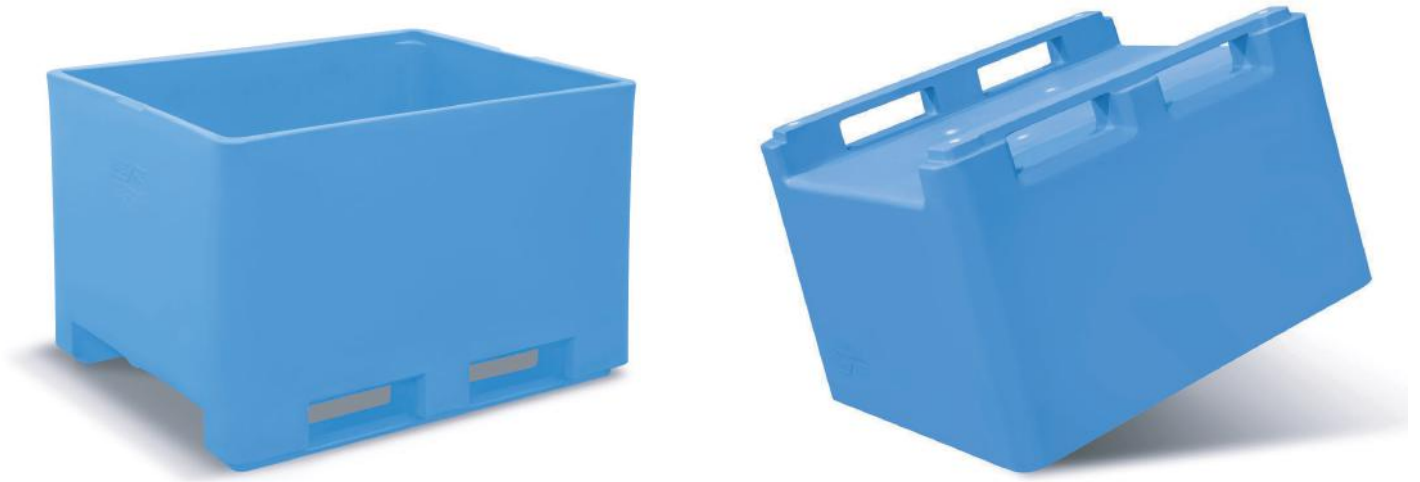

Cross-section of the sample container
with foamed polyethylene (PE) insulation

