



# **B** ADJUSTABLE HEIGHT PLATFORMS



**PERTH**  
(08) 9459 8600  
**KALGOORLIE**  
(08) 9021 8300

**ADELAIDE**  
(08) 8231 1513  
**NEWMAN**  
(08) 9175 1164

**DARWIN**  
(08) 8963 5621  
**MT ISA**  
(07) 4743 6458

✉ sales@bendtechgroup.com.au  
🌐 [bendtechgroup.com.au](http://bendtechgroup.com.au)

2-10 Kewdale Road, Welshpool WA 6106



## HEIGHT ADJUSTABLE PLATFORMS

# INDEX

<b>GIRAFFE SERIES BENEFITS</b>	<b>///</b>	<b>3 - 4</b>
<b>GIRAFFE G20 HEIGHT RANGE</b>	<b>///</b>	<b>6 - 7</b>
<b>GIRAFFE OPTIONAL ACCESSORIES</b>	<b>///</b>	<b>8</b>
<b>GIRAFFE G20 CONFIGURATIONS</b>	<b>///</b>	<b>9 - 16</b>
<b>MONKEY SERIES BENEFITS</b>	<b>///</b>	<b>17 - 18</b>
<b>MONKEY MX21 HEIGHT RANGE</b>	<b>///</b>	<b>20</b>
<b>MONKEY OPTIONAL ACCESSORIES</b>	<b>///</b>	<b>21 - 22</b>
<b>MONKEY MX21 CONFIGURATIONS</b>	<b>///</b>	<b>23 - 26</b>
<b>SQUIRREL SERIES BENEFITS</b>	<b>///</b>	<b>27 - 28</b>
<b>SQUIRREL S23 HEIGHT RANGE</b>	<b>///</b>	<b>30</b>
<b>SQUIRREL OPTIONAL ACCESSORIES</b>	<b>///</b>	<b>31 - 32</b>
<b>SQUIRREL S23 CONFIGURATIONS</b>	<b>///</b>	<b>33 - 36</b>





# GIRAFFE SERIES BENEFITS



**1**  
Efficient to climb with constant grade stair at any platform height



**2**  
Anti sway platform locks. Physical lock at every step height



**3**  
3 Gate gives access to work surface off the end or either side

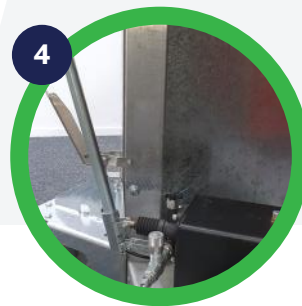

**4**  
Safe and steady height adjustment with hydraulic safety valve + decent speed control



**5**  
Minimal floor footprint that remains the same for all platform heights



**6**  
Easy to load and transport with forklift pockets in chassis



**7**  
Reach over obstacles with generous 1.74m platform

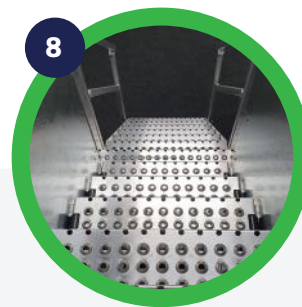

**8**  
Climb or descend spacious, easy gradient stairs effortlessly



# GIRAFFE SERIES BENEFITS



Replace multiple fixed height platforms with one versatile high quality multiuse unit. The result is a truly versatile workstation.

The Giraffe can nose its way into many different situations, giving comfortable, constant grade stair access. The wide, flat deck makes previously awkward, dangerous and time consuming jobs easy, safe, and very efficient.

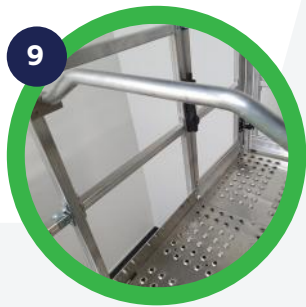

Prevent falls down the stair with the firm safety bar







# GIRAFFE G20 HEIGHT RANGE



Giraffe  
G20



WLL 300kg/660 lbs  
[www.equiptec.co](http://www.equiptec.co)



# GIRAFFE G20 HEIGHT RANGE

\*One base model reaching up to 4.7m

## GIRAFFE G20 Part No. 5800500

### CONSTRUCTION

- Deck height range: 1500mm – 2900mm
- Overall width: 1456mm
- Overall length: 4495mm
- Platform width: 780mm
- Platform length: 1786mm
- WLL: 300kg



## GIRAFFE G20 + 1 STEP Part No. 5800502

### CONSTRUCTION

- Deck height range: 1800mm – 3100mm
- Overall width: 1456mm
- Overall length: 4750mm
- Platform width: 780mm
- Platform length: 1786mm
- WLL: 300kg



## GIRAFFE G20 + 2 STEP Part No. 5800503

### CONSTRUCTION

- Deck height range: 2000mm – 3300mm
- Overall width: 1456mm
- Overall length: 4945mm
- Platform width: 780mm
- Platform length: 1786mm
- WLL: 300kg





## GIRAFFE

# G20 HEIGHT RANGE

\*One base model reaching up to 4.7m

### GIRAFFE G20 + 4 STEP

Part No. 5800504

#### CONSTRUCTION

- Deck height range: 2400mm – 3800mm
- Overall width: 1900mm
- Overall length: 5395mm
- Platform width: 780mm
- Platform length: 1786mm
- WLL: 300kg



### GIRAFFE G20 + 8 STEP

Part No. 5800505

#### CONSTRUCTION

- Deck height range: 3700mm – 4700mm
- Overall width: 2500mm
- Overall length: 7270mm
- Platform width: 780mm
- Platform length: 1786mm
- WLL: 300kg



“ **MAKING MAINTENANCE  
ON-SITE SAFE, EFFICIENT  
AND EASY** ”

**GIRAFFE**

**OPTIONAL ACCESSORIES**

The Giraffe G20 system includes many retrofittable accessories allowing you to configure a more exact solution for your access challenges.



**HAMMERHEAD DECK**

Part No. 5800507

- With a capacity of 200kg WLL this deck not only gives more room, but also offers both side gates and individually removable front facing gates. That's great unobstructed access to the workface on one or both sides.



**SLIDE OUT DECK**

Part No. 5800506

- The Slide Out Deck allows you to reach out up to 2.9m over an obstacle, even with a 150kg loading. It still features 3 exit gates as does the standard deck and rolls out effortlessly at any height.
- Once you are finished with it, simply slide it back in out of the way.



**ANGLED DECK**

Part No. 5800508

- When you are faced with tight space the G20 Angled Deck will save you precious room.
- With a 150kg capacity it includes an end gate and the same pack components can be assembled either to the right hand or left hand sides.



**ALL TERRAIN KIT**

- Larger diameter, heavy duty, towable wheels along with Jack Stands at each corner allow units with this accessory added to operate off the hard stand.
- With a level bubble on each corner, its easy to get the unit level and firm even if the ground is uneven.



**GIRAFFE****G20 CONFIGURATIONS****GIRAFFE G20 ENGINEERS  
MAINTENANCE STAIR****GIRAFFE G20 ENGINEERS  
MAINTENANCE STAIR W  
SLIDE OUT DECK****GIRAFFE G20 ENGINEERS  
MAINTENANCE STAIR W  
HAMMERHEAD DECK****GIRAFFE G20 + 1 STEP  
ENGINEERS MAINTENANCE  
STAIR**

# GIRAFFE G20 CONFIGURATIONS



**GIRAFFE G20 + 1 STEP  
ENGINEERS MAINTENANCE  
STAIR W SLIDE OUT DECK**



**GIRAFFE G20 + 1 STEP  
ENGINEERS MAINTENANCE  
STAIR W HAMMERHEAD DECK**



**GIRAFFE G20 + 2 STEP  
ENGINEERS MAINTENANCE  
STAIR**



**GIRAFFE G20 + 2 STEP  
ENGINEERS MAINTENANCE  
STAIR W SLIDE OUT DECK**



**GIRAFFE****G20 CONFIGURATIONS****GIRAFFE G20 + 2 STEP  
ENGINEERS MAINTENANCE  
STAIR W HAMMERHEAD DECK****GIRAFFE G20 + 4 STEP  
ENGINEERS MAINTENANCE  
STAIR****GIRAFFE G20 + 4 STEP  
ENGINEERS MAINTENANCE  
STAIR W SLIDE OUT DECK****GIRAFFE G20 + 4 STEP  
ENGINEERS MAINTENANCE  
STAIR W HAMMERHEAD DECK**



# GIRAFFE G20 CONFIGURATIONS



**GIRAFFE G20 + 8 STEP  
ENGINEERS MAINTENANCE  
STAIR**



**GIRAFFE G20 + 8 STEP  
ENGINEERS MAINTENANCE  
STAIR W SLIDE OUT DECK**



**GIRAFFE G20 + 8 STEP  
ENGINEERS MAINTENANCE  
STAIR W HAMMERHEAD DECK**



**GIRAFFE G20 ALL TERRAIN  
ENGINEERS MAINTENANCE  
STAIR**





**GIRAFFE**

# **G20 CONFIGURATIONS**

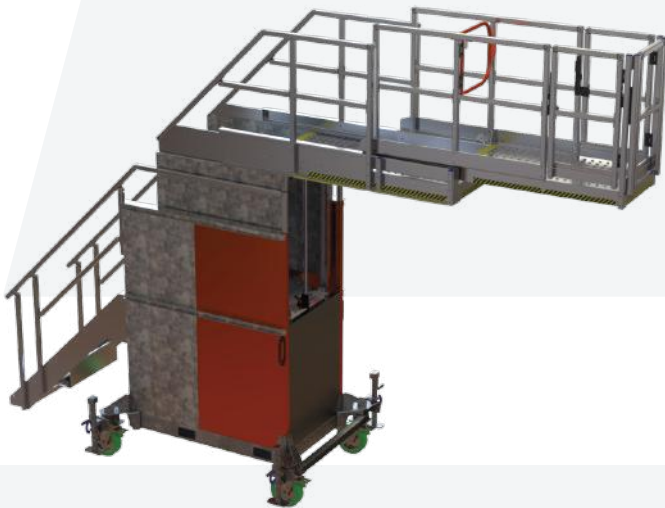

**GIRAFFE G20 ALL TERRAIN  
ENGINEERS MAINTENANCE  
STAIR W SLIDE OUT DECK**



**GIRAFFE G20 ALL TERRAIN  
ENGINEERS MAINTENANCE  
STAIR W HAMMERHEAD DECK**

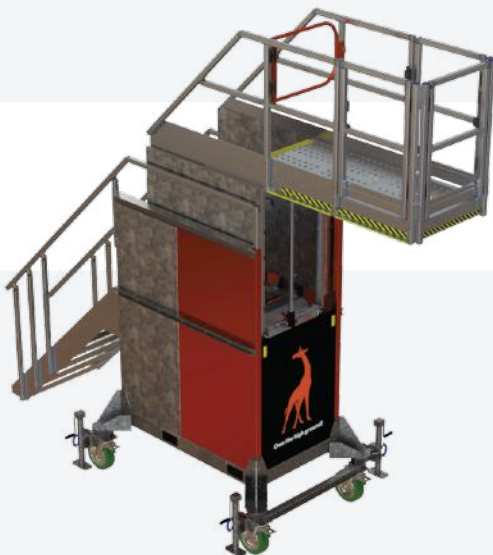

**GIRAFFE G20 ALL TERRAIN  
+ 1 STEP ENGINEERS  
MAINTENANCE STAIR**



**GIRAFFE G20 ALL TERRAIN + 1  
STEP ENGINEERS MAINTENANCE  
STAIR W SLIDE OUT DECK**



**GIRAFFE**  
**G20 CONFIGURATIONS**



**GIRAFFE G20 ALL TERRAIN + 1  
STEP ENGINEERS MAINTENANCE  
STAIR W HAMMERHEAD DECK**



**GIRAFFE G20 ALL TERRAIN + 2  
STEP ENGINEERS MAINTENANCE  
STAIR**



**GIRAFFE G20 ALL TERRAIN + 2  
STEP ENGINEERS MAINTENANCE  
STAIR W SLIDE OUT DECK**



**GIRAFFE G20 ALL TERRAIN + 2  
STEP ENGINEERS MAINTENANCE  
STAIR W HAMMERHEAD DECK**







**GIRAFFE**

# **G20 CONFIGURATIONS**



**GIRAFFE G20 ALL TERRAIN + 4  
STEP ENGINEERS MAINTENANCE  
STAIR**



**GIRAFFE G20 ALL TERRAIN + 4  
STEP ENGINEERS MAINTENANCE  
STAIR W SLIDE OUT DECK**



**GIRAFFE G20 ALL TERRAIN + 4  
STEP ENGINEERS MAINTENANCE  
STAIR W HAMMERHEAD DECK**



**GIRAFFE G20 ALL TERRAIN + 8  
STEP ENGINEERS MAINTENANCE  
STAIR**



**GIRAFFE**  
**G20 CONFIGURATIONS**

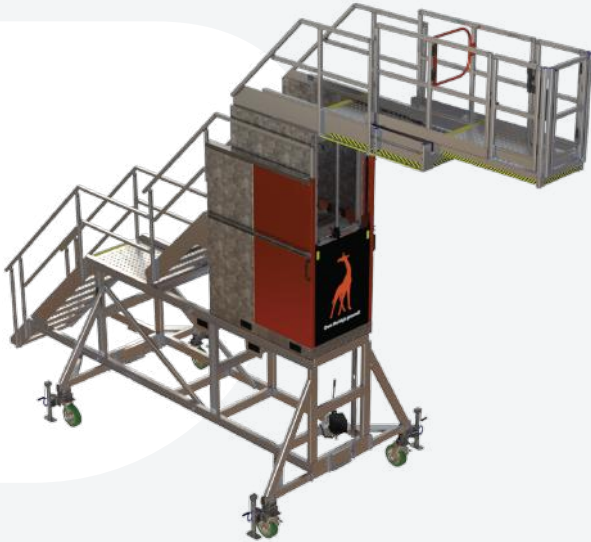

**GIRAFFE G20 ALL TERRAIN + 8  
STEP ENGINEERS MAINTENANCE  
STAIR W SLIDE OUT DECK**



**GIRAFFE G20 ALL TERRAIN + 8  
STEP ENGINEERS MAINTENANCE  
STAIR W HAMMERHEAD DECK**

“ **MAKING MAINTENANCE  
ON-SITE SAFE, EFFICIENT  
AND EASY** ”



**MONKEY SERIES**  
**BENEFITS**

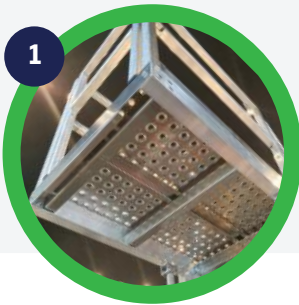

**1**  
Extra tough, sturdy and stable workdeck with fully compliant guard and handrails



**2**  
Room to work on this generously sized work deck...it will handle you and your gear, WLL250kg / 551lb



**3**  
Self closing, full size front gate



**4**  
Convenient, solid rear sprung loaded gate

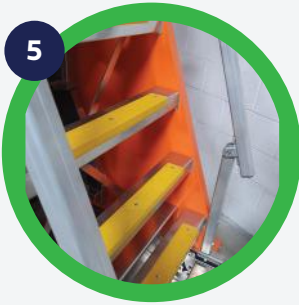

**5**  
Easy to climb with constant grade access and super tough, anti slip hi-viz treads

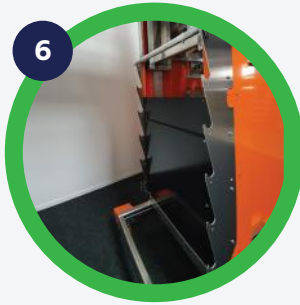

**6**  
Fits multiple jobs with 6 height instalments. Minimal floor footprint that remains the same for all platform heights



**7**  
Rapid spring assisted adjustment



# MONKEY SERIES BENEFITS



A solitary Monkey MX21 can replace multiple fixed height platforms.  
The Monkey can be used as both a work deck or an accessway.  
Efficient in use and efficient to store...here are a few more great Monkey benefits!

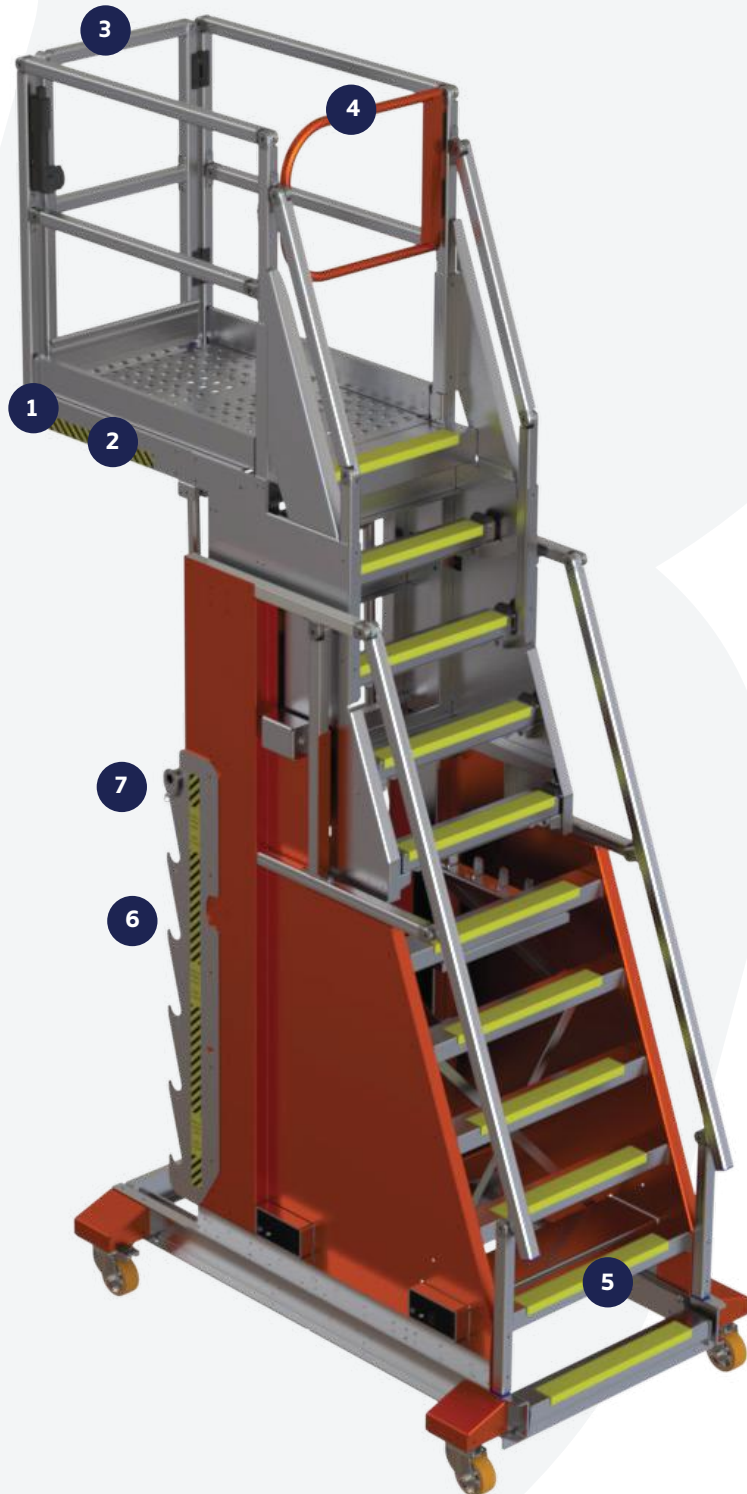

**3**

**3** **BIGGER  
THAN  
BUSINESS**

# **MONKEY MX21 HEIGHT RANGE**

  
Monkey  
MX21  
WLL 250kg/551 lbs  
www.equiptec.co

 [www.bendtechgroup.com.au](http://www.bendtechgroup.com.au)

**3**

**MONKEY**

**MX21 HEIGHT RANGE**

\*One base model reach up to 5.75m / 18 1/2 ft

**MONKEY MX21**

Part No. 5600543

**CONSTRUCTION**

- Deck height range: 1500mm – 2750mm
- Overall width: 1177mm
- Overall length: 2242mm
- Platform width: 642mm
- Platform length: 1041mm
- Max Reach Height: 4.75m



**MONKEY MX21 + 4 STEP**

**CONSTRUCTION**

- Deck height range: 2500mm – 3750mm
- Overall width: 1177mm
- Overall length: 2684mm
- Platform width: 642mm
- Platform length: 1041mm
- Max Reach Height: 5.75m





## MONKEY

# OPTIONAL ACCESSORIES

The Monkey MX21 system includes many retrofittable base options allowing you to configure a more exact solution for your access challenges.



### EXTENDED CANTILEVER

- The Extended Cantilever option gives awesome reach capacity - up to 1.2m / 4 ft straight out! This 'bolt on' accessory (including the neatly stowed counterweight system) creates an amazing long deck that noses right up to that difficult job. Note this option will reduce the WLL to 150kg / 330lb.



### HAMMERHEAD DECK

- This option still maintains a 200kg / 441lb WWL and allows unobstructed access across a wide 1.8m / 5.9ft front.
- Ideal for working on wide wall areas, or for jobs where two people are required.



### GO-BASE

- Glide around the workshop on 4 wheels. For longer distance moves, use the front wheel directional locks for easy guidance. Flick them off again in seconds for close up manoeuvres if needed. And when you are set to climb, just standing on the bottom tread auto locks all 4 wheel brakes firmly!



### ALL TERRAIN KIT

- This option allows you to work outdoors and off the hard stand. With 4 rubber wheels the MX21 can be pushed over metal yards and it also has 4 independently adjustable jacks that provide both stability and the ability to level the MX21 on undulating sites.

**MONKEY**

**OPTIONAL ACCESSORIES**

The Monkey MX21 system includes many retrofittable base options allowing you to configure a more exact solution for your access challenges.



**4 STEP SUB CHASSIS**

- Additional height is gained through sub chassis extension kits. These fit easily with all other base kits (Go-Base + All Terrain) and the height adjusting ratchet is lowered so it remains at a comfortable reach height.

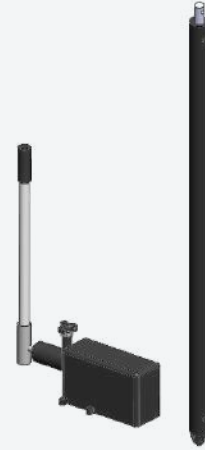

**HYDRAULIC KIT**

- The smooth operation, double action Hydraulic kit makes light work of adjusting deck height, even with additional weight kits such as the Extended Cantilever or Hammerhead Deck.

**MONKEY**

# **MX21 CONFIGURATIONS**



**MONKEY MX21 ENGINEERS  
MAINTENANCE STEPS  
+ GO-BASE**



**MONKEY MX21 ENGINEERS  
MAINTENANCE STEPS  
+ GO-BASE W HYDRAULICS**



**MONKEY MX21 ENGINEERS  
MAINTENANCE STEPS  
+ GO-BASE W HYDRAULICS  
+ EXTENDED CANTILEVER**



**MONKEY MX21 ENGINEERS  
MAINTENANCE STEPS  
+ GO-BASE W HYDRAULICS  
+ HAMMERHEAD DECK**



**MONKEY**  
**MX21 CONFIGURATIONS**



**MONKEY MX21 ENGINEERS  
MAINTENANCE STEPS  
+ ALL TERRAIN KIT**



**MONKEY MX21 ENGINEERS  
MAINTENANCE STEPS + ALL  
TERRAIN KIT W HYDRAULICS**



**MONKEY MX21 ENGINEERS  
MAINTENANCE STEPS + ALL  
TERRAIN KIT W HYDRAULICS  
+ HAMMERHEAD DECK**



**MONKEY MX21 ENGINEERS  
MAINTENANCE STEPS  
+ 4 STEP W GO-BASE**

**MONKEY**

# **MX21 CONFIGURATIONS**



**MONKEY MX21 ENGINEERS  
MAINTENANCE STEPS + 4 STEP  
SUB CHASSIS W GO-BASE +  
HYDRAULICS**



**MONKEY MX21 ENGINEERS  
MAINTENANCE STEPS + 4 STEP  
SUB CHASSIS W GO-BASE +  
HYDRAULICS + EXTENDED  
CANTILEVER**



**MONKEY MX21 ENGINEERS  
MAINTENANCE STEPS + 4 STEP  
SUB CHASSIS W GO-BASE +  
HYDRAULICS + HAMMERHEAD  
DECK**



**MONKEY MX21 ENGINEERS  
MAINTENANCE STEPS + 4 STEP  
SUB CHASSIS W ALL TERRAIN**

**MONKEY**  
**MX21 CONFIGURATIONS**



**MONKEY MX21 ENGINEERS  
MAINTENANCE STEPS + 4 STEP  
SUB CHASSIS W ALL TERRAIN +  
HYDRAULICS**



**MONKEY MX21 ENGINEERS  
MAINTENANCE STEPS + 4 STEP  
SUB CHASSIS W ALL TERRAIN +  
HYDRAULICS + HAMMERHEAD  
DECK**

“ **MAKING MAINTENANCE  
ON-SITE SAFE, EFFICIENT  
AND EASY** ”



# SQUIRREL SERIES BENEFITS



**1**  
Extra tough, sturdy and stable workdeck with fully compliant guard and handrails



**2**  
Room to work on this generously sized work deck...it will handle you and your gear, WLL200kg / 441lb



**3**  
Self closing, full size front gate



**4**  
Convenient, solid rear sprung loaded gate

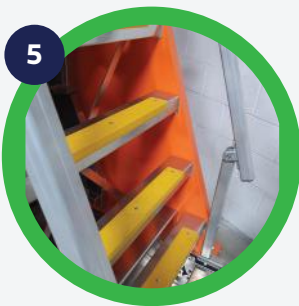

**5**  
Easy to climb with constant grade access and super tough, anti slip hi-viz treads

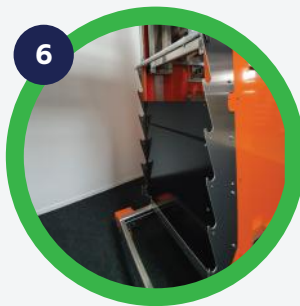

**6**  
Fits multiple jobs with 4 height instalments. Minimal floor footprint that remains the same for all platform heights



**7**  
Rapid spring assisted adjustment

# SQUIRREL SERIES BENEFITS



A solitary Squirrel S23 can replace multiple fixed height platforms. The Squirrel can be used as both a work deck or an accessway. Efficient in use and efficient to store...here are a few more great Squirrel benefits!





# SQUIRREL S23 HEIGHT RANGE

 [www.bendtechgroup.com.au](http://www.bendtechgroup.com.au)







# SQUIRREL S23 HEIGHT RANGE

\*One base model - reach up to 4.4m / 14 1/4 ft

## SQUIRREL S23

### CONSTRUCTION

- Deck height range: 750mm - 1500mm
- Overall width: 1047mm
- Overall length: 1596mm
- Platform width: 516mm
- Platform length: 856mm
- Max Reach Height: 3.5m



## SQUIRREL S23 + 2 STEP

### CONSTRUCTION

- Deck height range: 1250mm - 2000mm
- Overall width: 1047mm
- Overall length: 1868mm
- Platform width: 516mm
- Platform length: 856mm
- Max Reach Height: 4.0m



## SQUIRREL S23 + 4 STEP

### CONSTRUCTION

- Deck height range: 1750mm - 2500mm
- Overall width: 1047mm
- Overall length: 2187mm
- Platform width: 516mm
- Platform length: 856mm
- Max Reach Height: 4.5m



**SQUIRREL****OPTIONAL ACCESSORIES**

The Squirrel S23 system includes many retrofittable base options allowing you to configure a more exact solution for your access challenges.

**EXTENDED CANTILEVER**

- Its often necessary to reach over obstacles to get to your project. The Extended Cantilever option gives awesome reach capacity - up to 630mm /24.8 in straight out! This 'bolt on' accessory (including the neatly stowed counterweight system) creates an amazing long deck that noses right up to that difficult job.

**GO-BASE**

- Glide around the workshop on 4 wheels. For longer distance moves, use the front wheel directional locks for easy guidance. Flick them off again in seconds for close up manoeuvres if needed. And when you are set to climb, just standing on the bottom tread auto locks all 4 wheel brakes firmly!

**NARROW GO-BASE**

- All the same attributes of the Standard Go-Base, but condensed to fit within the width of the Squirrel frame. Excellent for areas with restricted maneuvering room and all counterbalanced to retain the same excellent stability.

**ALL TERRAIN KIT**

- This option allows you to work outdoors and off the hard stand. With 4 rubber wheels the S23 can be pushed over metal yards and it also has 4 independantly adjustable jacks that provide both stability and the ability to level the S23 on undulating sites.

**SQUIRREL**

**OPTIONAL ACCESSORIES**

The Squirrel S23 system includes many retrofittable base options allowing you to configure a more exact solution for your access challenges.



**STEP SUB CHASSIS**

- Additional height is gained through sub chassis extension kits. These fit easily with all other base kits (Go-Base + All Terrain) and the height adjusting ratchet is lowered so it remains at a comfortable reach height where applicable.







**SQUIRREL**  
**S23 CONFIGURATIONS**



**SQUIRREL S23 ENGINEERS  
 MAINTENANCE STEPS +  
 GO-BASE**



**SQUIRREL S23 ENGINEERS  
 MAINTENANCE STEPS +  
 GO-BASE W EXTENDED  
 CANTILEVER**



**SQUIRREL S23 ENGINEERS  
 MAINTENANCE STEPS +  
 NARROW GO-BASE**



**SQUIRREL S23 ENGINEERS  
 MAINTENANCE STEPS +  
 NARROW GO-BASE W  
 EXTENDED CANTILEVER**

# SQUIRREL S23 CONFIGURATIONS



**SQUIRREL S23 ENGINEERS  
MAINTENANCE STEPS +  
ALL TERRAIN**



**SQUIRREL S23 ENGINEERS  
MAINTENANCE STEPS +  
ALL TERRAIN W EXTENDED  
CANTILEVER**



**SQUIRREL S23 ENGINEERS  
MAINTENANCE STEPS +  
2 STEP W GO-BASE**



**SQUIRREL S23 ENGINEERS  
MAINTENANCE STEPS +  
2 STEP W GO-BASE W  
EXTENDED CANTILEVER**



**SQUIRREL**  
**S23 CONFIGURATIONS**



**SQUIRREL S23 ENGINEERS  
 MAINTENANCE STEPS + 2  
 STEP W NARROW GO-BASE**



**SQUIRREL S23 ENGINEERS  
 MAINTENANCE STEPS + 2  
 STEP W NARROW GO-BASE  
 + EXTENDED CANTILEVER**



**SQUIRREL S23 ENGINEERS  
 MAINTENANCE STEPS + 2  
 STEP W ALL TERRAIN**



**SQUIRREL S23 ENGINEERS  
 MAINTENANCE STEPS + 4  
 STEP W GO-BASE**



**SQUIRREL**  
**S23 CONFIGURATIONS**



**SQUIRREL S23 ENGINEERS  
MAINTENANCE STEPS +  
4 STEP W GO-BASE +  
EXTENDED CANTILEVER**



**SQUIRREL S23 ENGINEERS  
MAINTENANCE STEPS +  
4 STEP W ALL TERRAIN**









**DARWIN**  
08 8963 5621

**MOUNT ISA**  
07 4743 6458

**NEWMAN**  
08 9175 1164

**PERTH**  
08 9459 8600

**KALGOORLIE**  
08 9021 8300

**ADELAIDE**  
08 8231 1513